

RoHS Compliant Multi-Rate CWDM SFP Transceiver for Fast Ethernet, ATM and SONET/SDH STM-1/OC-3 with DDM Function



FEATURES

- Compliant with SFP Transceiver SFF-8472 MSA specification with internal calibration
- Multirate operation from 100Mb/s to 155Mb/s
- Single + 3.3V Power Supply and TTL Logic Interface
- 8 Wavelength () Uncooled CWDM DFB laser LD transmitter and PIN receiver
- EEPROM with Serial ID Functionality
- Laser Class 1 Product which comply with the requirements of IEC 60825-1 and IEC 60825-2
- Duplex LC Connector interface

Description

The LCP-155 CWDM series are designed for coarse wavelength division multiplexing applications (CWDM) and hot pluggable SFP transceiver modules that data rates up to 155 Mb/s. The LCP-155 CWDM series are support Fast Ethernet, ATM and OC-3/SDH STM-1 standards. The selectiveness of center wavelength has 1470, 1490, 1510, 1530, 1550, 1570, 1590, and 1610 nm.

The LCP-155 CWDM series are designed to be compliant with SFF-8472 SFP Multi-source Agreement (MSA) with digital diagnostic monitoring functions: Temperature, V_{CC} , TX optical power, TX laser bias current, and RX received optical power.

The post-amplifier of the LCP-155 CWDM series also includes a Loss of Signal (LOS) circuit that provides a TTL logic-high output when the received optical level is below a preset LOS Assert threshold.

Applications

- OC-3/SDH STM-1
- Fast Ethernet and ATM
- Switch to Switch interface
- Switched backplane applications
- File server interface

Performance

- LCP-155D4RxxR: 1470nm to 1610nm CWDM DFB laser, 29dB link budget
- LCP-155D4VxxR: 1470nm to 1610nm CWDM DFB laser, 33dB link budget
- LCP-155D4UxxR: 1470nm to 1610nm CWDM DFB laser, 36dB link budget



Absolute Maximum Ratings

Parameter	Symbol	Min.	Typ.	Max.	Unit	Note
Storage Temperature	Ts	-40		85	°C	
Supply Voltage	VCC	0		5	V	

Recommended Operating Conditions

Parameter	Symbol	Min.	Typ.	Max.	Unit	Note
Case Operating Temperature	Tc	-5		70	°C	1
Supply Voltage	VCC	3.135		3.465	V	
Data Rate			155		Mbps	

Note 1: See order information

Electrical Characteristics

(V_{CC}=3.3V ± 5%)

Parameter	Symbol	Min.	Typ.	Max.	Unit	Note
Total Supply Current						
LCP-155D4xxxR	ICCT			300	mA	
LCP-155D4xxxRH				380		
LCP-155D4xxxRT				380		
Transmitter						
Transmitter Differential Input Voltage	VDT	0.5		2.4	V	1
Transmitter Disable Input-High	V _{DISH}	2		V _{CC}	V	
Transmitter Disable Input-Low	V _{DISL}	V _{ee}		0.8	V	
Transmitter Fault Pull up Resistor	R _{TX_FAULT}	4.7		10	kΩ	2
Transmitter Fault Output-High	V _{TXFH}	2		V _{CC}	V	
Transmitter Fault Output-Low	V _{TXFL}	V _{ee}		0.8	V	
Receiver						
Receiver Differential Output Voltage	VDR	0.35		2	V	3
Receiver LOS Load	R _{RXLOS}	4.7		10	kΩ	2
LOS Output Voltage-High	V _{LOSH}	2		V _{CC}	V	
LOS Output Voltage-Low	V _{LOSL}	V _{ee}		0.8	V	
Output Data Rise/Fall Time	t _r / t _f			2.5	nsec	4

Notes:

1. Internally AC coupled and terminated to 100Ohm differential load.
2. Pull up to V_{CC} on host Board.
3. Internally AC coupled, but requires a 100Ohm differential termination at or internal to Serializer/ Deserializer.
4. These are 20%~80% values.



Optical Characteristics

Transmitter

($V_{CC}=3.3V \pm 5\%$, Data Rate=155Mb/sec, PRBS= $2^{23}-1$ NRZ)

Parameter	Symbol	Min.	Typ.	Max.	Unit	Note
Output Optical Power (Avg.)						
LCP-155D4RxxR	P	-5		0	dBm	
LCP-155D4VxxR		-3		+2		
LCP-155D4UxxR		0		+5		
Optical Extinction Ratio	ER	9			dB	
Center Wavelength						
LCP-155D4x47R	c	1464.5	1470	1477.5	nm	
LCP-155D4x49R		1484.5	1490	1497.5		
LCP-155D4x51R		1504.5	1510	1517.5		
LCP-155D4x53R		1524.5	1530	1537.5		
LCP-155D4x55R		1544.5	1550	1557.5		
LCP-155D4x57R		1564.5	1570	1577.5		
LCP-155D4x59R		1584.5	1590	1597.5		
LCP-155D4x61R		1604.5	1610	1617.5		
Spectral Width (-20dB)				1	nm	
Side-mode Suppression Ratio	SMSR	30			dB	
Optical Rise/ Fall Time	t_r/t_f			2	nsec	1
Relative Intensity Noise	RIN			-120	dB/Hz	
Output Eye	Compliant with ITU-T G.957					

Receiver

($V_{CC}=3.3V \pm 5\%$, Data Rate=155Mb/sec, PRBS= $2^{23}-1$ NRZ)

Parameter	Symbol	Min.	Typ.	Max.	Unit	Note
Sensitivity (Avg.)						
LCP-155D4RxxR	P _s			-34	dBm	2
LCP-155D4VxxR				-36		
LCP-155D4UxxR				-36		
Input Optical Wavelength		1270		1620	nm	
LOS-Deasserted (Avg.)						
LCP-155D4RxxR	P _A			-34	dBm	
LCP-155D4VxxR				-36		
LCP-155D4UxxR				-36		
LOS-Asserted (Avg.)	P _D	-45			dBm	
LOS-Hysteresis	P _A -P _D	0.5			dB	
Overload	P ₀	-3			dBm	
Reflectance	r			-12	dB	

Notes:

1. These are unfiltered 20%~80% values.
2. The sensitivity is provided at a BER of 1×10^{-10} or better with an input signal consisting of 155Mb/s, $2^{23}-1$ PRBS and ER=9dB.

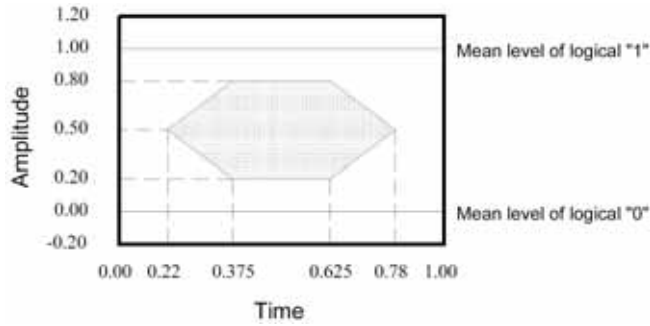

Mask of the eye diagram for the optical transmit signal

Recommend Circuit Schematic

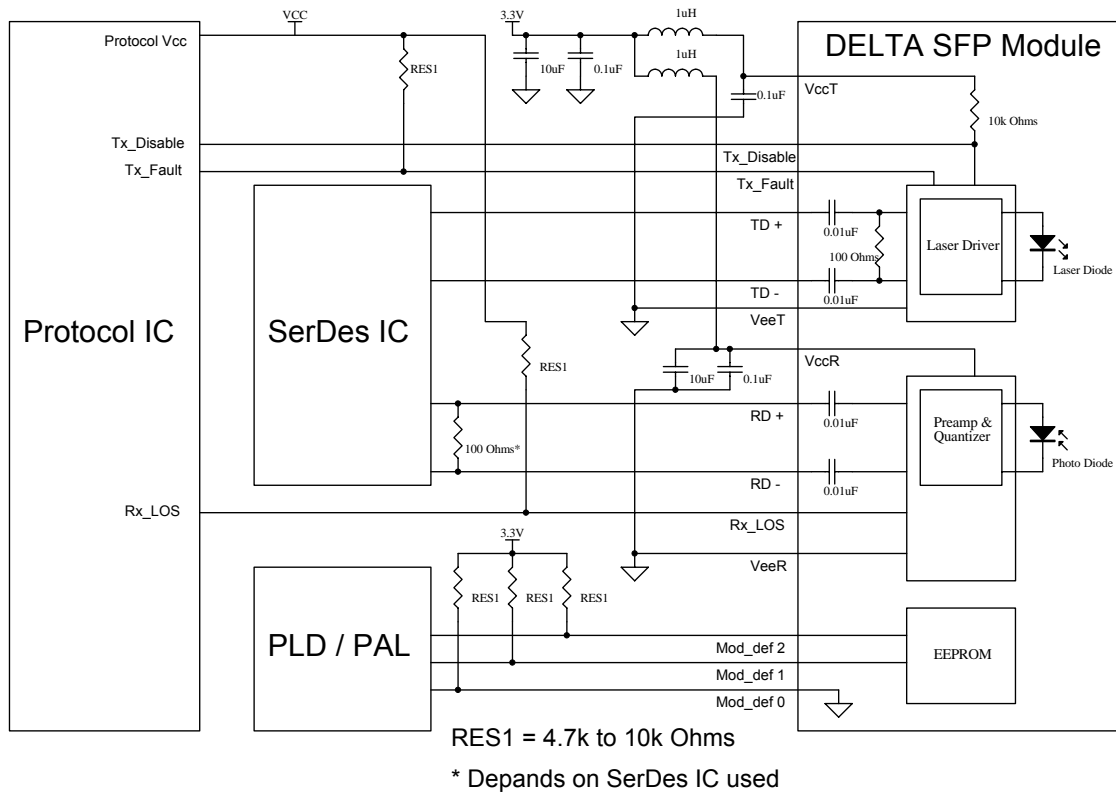

SFP Transceiver Electrical Pad Layout

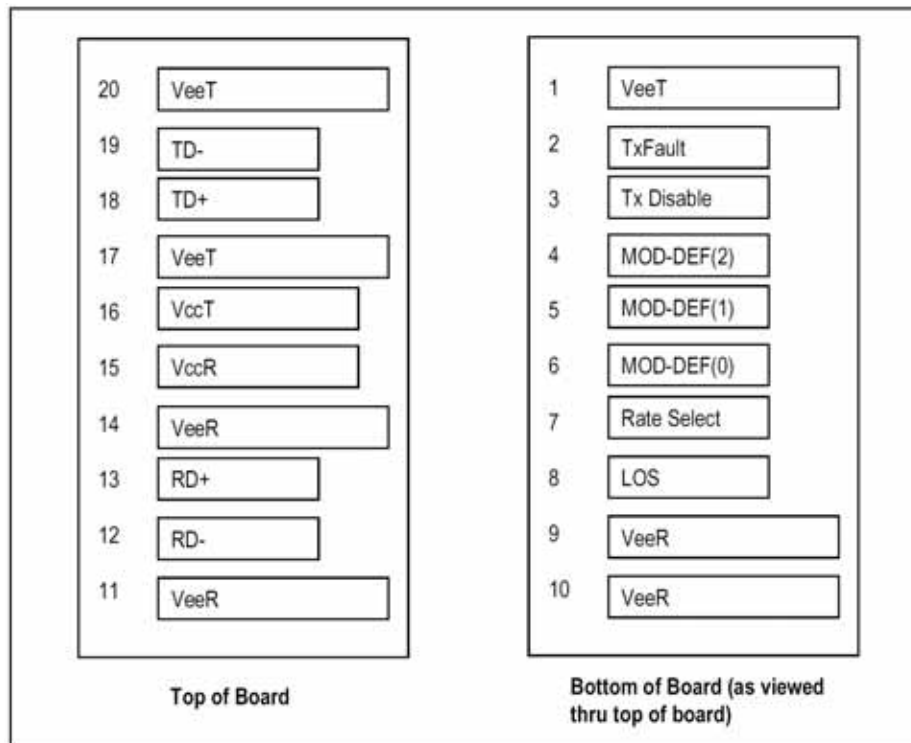

Pin Function Definitions

Pin Num.	Name	Function	Plug Seq.	Notes
1	VeeT	Transmitter Ground	1	
2	TX Fault	Transmitter Fault Indication	3	Note 1
3	TX Disable	Transmitter Disable	3	Note 2, Module disables on high or open
4	MOD-DEF2	Module Definition 2	3	Note 3, 2 wire serial ID interface
5	MOD-DEF1	Module Definition 1	3	Note 3, 2 wire serial ID interface
6	MOD-DEF0	Module Definition 0	3	Note 3, Grounded in Module
7	Rate Select	Not Connect	3	Function not available
8	LOS	Loss of Signal	3	Note 4
9	VeeR	Receiver Ground	1	Note 5
10	VeeR	Receiver Ground	1	Note 5
11	VeeR	Receiver Ground	1	Note 5
12	RD-	Inv. Received Data Out	3	Note 6
13	RD+	Received Data Out	3	Note 7
14	VeeR	Receiver Ground	1	Note 5
15	VccR	Receiver Power	2	3.3 ± 5%, Note 7
16	VccT	Transmitter Power	2	3.3 ± 5%, Note 7
17	VeeT	Transmitter Ground	1	Note 5
18	TD+	Transmit Data In	3	Note 8
19	TD-	Inv. Transmit Data In	3	Note 8
20	VeeT	Transmitter Ground	1	Note 5

Plug Seq.: Pin engagement sequence during hot plugging.

Notes:

- 1) TX Fault is an open collector/drain output, which should be pulled up with a 4.7K – 10K Ω resistor on the host board. Pull up voltage between 2.0V and VccT, R+0.3V. When high, output indicates a laser fault of some kind. Low indicates normal operation. In the low state, the output will be pulled to < 0.8V.
- 2) TX disable is an input that is used to shut down the transmitter optical output. It is pulled up within the module with a 4.7 – 10 K Ω resistor. Its states are:
Low (0 – 0.8V): Transmitter on
(>0.8, < 2.0V): Undefined
High (2.0 – 3.465V): Transmitter Disabled
Open: Transmitter Disabled
- 3) Mod-Def 0,1,2. These are the module definition pins. They should be pulled up with a 4.7K – 10K Ω resistor on the host board. The pull-up voltage shall be VccT or VccR (see Section IV for further details). Mod-Def 0 is grounded by the module to indicate that the module is present Mod-Def 1 is the clock line of two wire serial interface for serial ID Mod-Def 2 is the data line of two wire serial interface for serial ID
- 4) LOS (Loss of Signal) is an open collector/drain output, which should be pulled up with a 4.7K – 10K Ω resistor. Pull up voltage between 2.0V and VccT, R+0.3V. When high, this output indicates the received optical power is below the worst-case receiver sensitivity (as defined by the standard in use). Low indicates normal operation. In the low state, the output will be pulled to < 0.8V.
- 5) VeeR and VeeT may be internally connected within the SFP module.
- 6) RD-/+: These are the differential receiver outputs. They are AC coupled 100 Ω differential lines which should be terminated with 100 Ω (differential) at the user SERDES. The AC coupling is done inside the module and is thus not required on the host board. The voltage swing on these lines will be between 370 and 2000 mV differential (185 – 1000 mV single ended) when properly terminated.
- 7) VccR and VccT are the receiver and transmitter power supplies. They are defined as 3.3V \pm 5% at the SFP connector pin. Maximum supply current is 300mA. Recommended host board power supply filtering is shown below. Inductors with DC resistance of less than 1 ohm should be used in order to maintain the required voltage at the SFP input pin with 3.3V supply voltage. When the recommended supply-filtering network is used, hot plugging of the SFP transceiver module will result in an inrush current of no more than 30mA greater than the steady state value. VccR and VccT may be internally connected within the SFP transceiver module.
- 8) TD-/+: These are the differential transmitter inputs. They are AC-coupled, differential lines with 100 Ω differential termination inside the module. The AC coupling is done inside the module and is thus not required on the host board. The inputs will accept differential swings of 500 – 2400 mV (250 – 1200 mV single-ended), though it is recommended that values between 500 and 1200 mV differential (250 – 600 mV single-ended) be used for best EMI performance.

SFP timing parameters for SFP management

Parameter	Symbol	Min.	Max.	Unit	Note
TX_DISABLE Assert time	t_off		10	μsec	1
TX_DISABLE Negate time	t_on		1	msec	2
Time to initialize, including reset of TX_FAULT	t_init		300	msec	3
TX Fault Assert Time	t_fault		100	μsec	4
TX_DISABLE to reset	t_rest	10		μsec	5
LOS Assert Time	t_loss_on		100	μsec	6
LOS Deassert Time	t_loss_off		100	μsec	7
Serial ID Clock Rate	f_serial_clock		100	kHz	

Notes:

- 1) Time from rising edge of TX_DISABLE to when the optical output falls below 10% of nominal.
- 2) Time from falling edge of TX_DISABLE to when the modulated optical output rises above 90% of nominal.
- 3) From power on or negation of TX_Fault using TX Disable.
- 4) Time from fault to TX fault on.
- 5) Time TX Disable must be held high to reset TX_Fault
- 6) Time from LOS state to Rx LOS assert
- 7) Time from non-LOS state to Rx LOS deassert

Package Outline Drawing

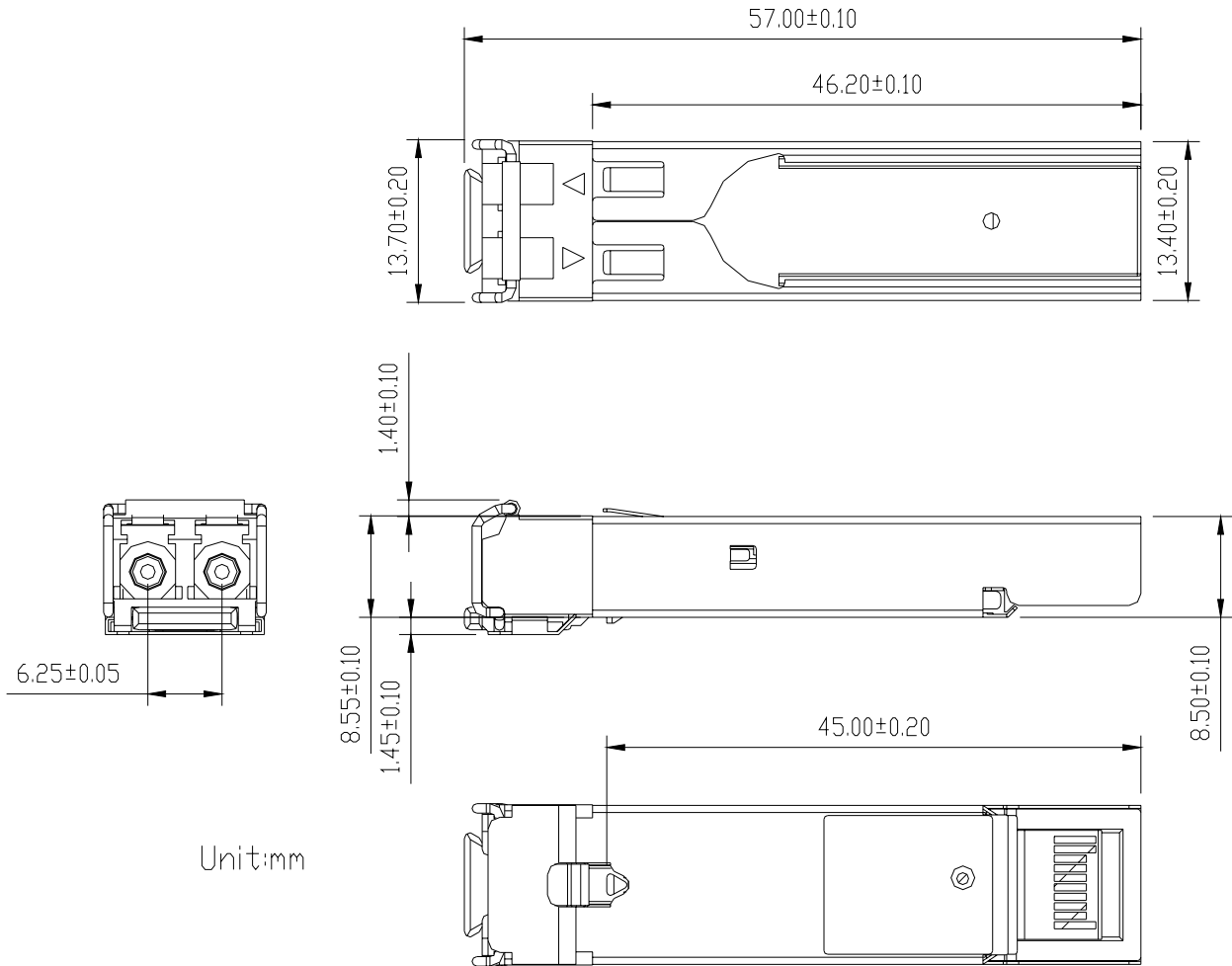

Enhanced Digital Diagnostic Interface

The memory map in the following describes an extension to the memory map defined in SFP MSA. The enhanced interface uses the two wire serial bus address 1010001X(A2h) to provide diagnostic information about the module's present operating conditions.

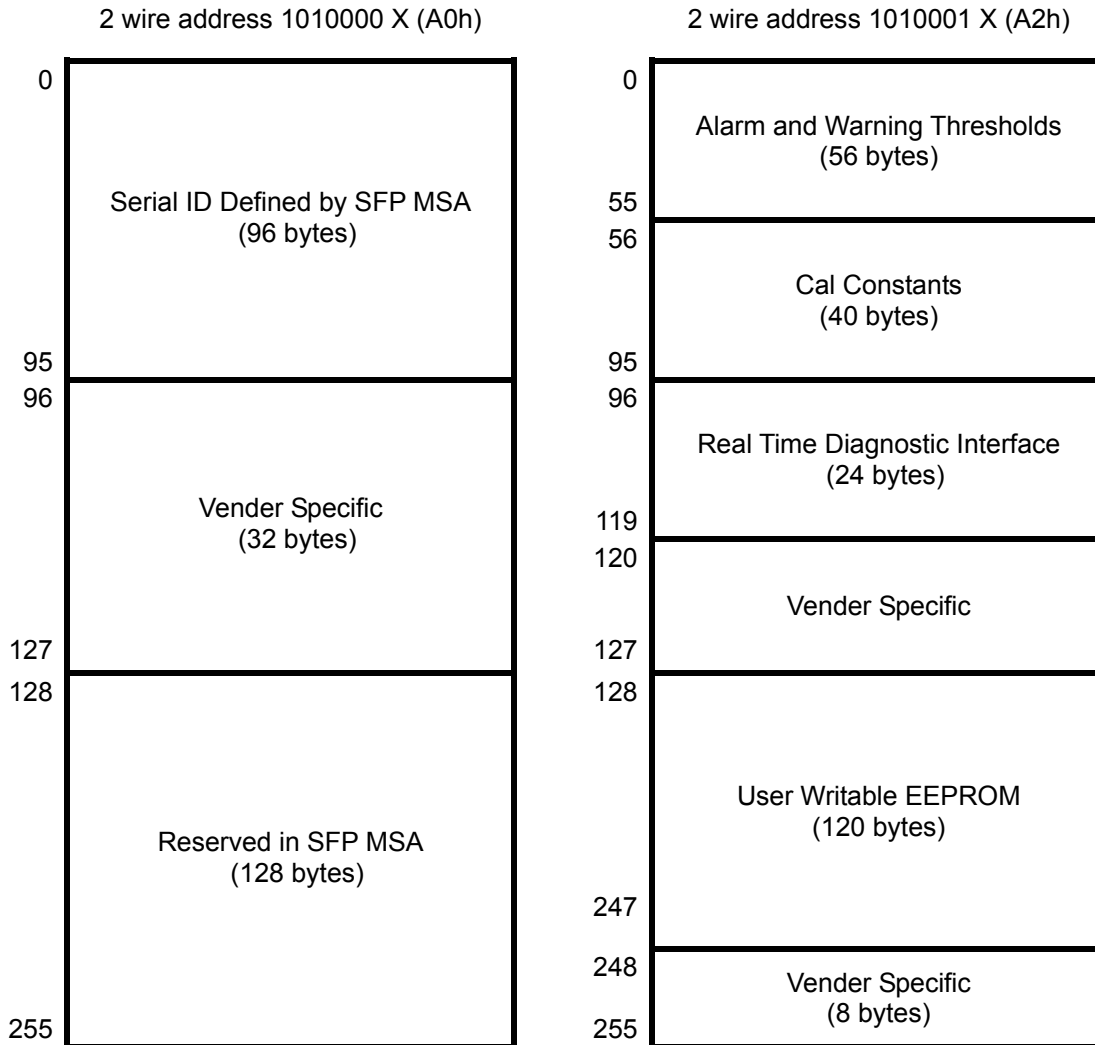

Digital Diagnostic Memory Map Specific Data Field Descriptions

EEPROM Serial ID Memory Contents (2-Wire Address A0h)

Address	Hex	ASCII	Address	Hex	ASCII	Address	Hex	ASCII
00	03		43	PN		86	DC	
01	04		44	PN		87	DC	
02	07		45	PN		88	DC	
03	00	Note 1	46	PN		89	DC	
04	xx		47	PN		90	DC	
05	xx		48	PN		91	DC	
06	xx		49	PN		92	68	
07	00		50	PN		93	B0	
08	00		51	PN		94	02	
09	00		52	PN		95	CS2	Note 9
10	00		53	PN		96	00	
11	03		54	PN		97	00	
12	02		55	PN		98	00	
13	00		56	30		99	00	
14	xx	Note 2	57	30		100	00	
15	FF	Note 3	58	30		101	00	
16	00		59	41		102	00	
17	00		60	CW	Note 5	103	00	
18	00		61	CW	Note 5	104	00	
19	00		62	00		105	00	
20	44	D	63	CS1	Note 6	106	00	
21	45	E	64	00		107	00	
22	4C	L	65	1A		108	00	
23	54	T	66	00		109	00	
24	41	A	67	00		110	00	
25	20		68	SN	Note 7	111	00	
26	20		69	SN		112	00	
27	20		70	SN		113	00	
28	20		71	SN		114	00	
29	20		72	SN		115	00	
30	20		73	SN		116	00	
31	20		74	SN		117	00	
32	20		75	SN		118	00	
33	20		76	SN		119	00	
34	20		77	SN		120	00	
35	20		78	SN		121	00	
36	00		79	SN		122	00	
37	00		80	SN		123	00	
38	00		81	SN		124	00	
39	00		82	SN		125	00	
40	PN	Note 4	83	SN		126	00	
41	PN		84	DC	Note 8	127	00	
42	PN		85	DC		128	00	Note 10

Notes:

- 1) Byte 3~10: Code for electronic compatibility or optical compatibility.
- 2) Byte 14: Transmission distance in km.
- 3) Byte 15: Transmission distance in 100m, distance >25.5km: FFh.
- 4) Byte 40-55: Delta part number.
- 5) Byte 60-61: The center wavelength of transmitter.
- 6) Byte 63: Check sum of bytes 0-62.
- 7) Byte 68-83: Serial number.

- 8) Byte 84-91: Date code.
- 9) Byte 95: Check sum of bytes 64-94.
- 10) Byte 128 to 255 had been set hex 00.

Digital Diagnostic Monitoring Interface

Alarm and Warning Thresholds (2-Wire Address A2h)

Address	# Bytes	Name	Value (Dec.)	Unit	Note
00-01	2	Temp High Alarm	$T_C(\text{MAX.})+15$		1
02-03	2	Temp Low Alarm	$T_C(\text{MIN.})$		
04-05	2	Temp High Warning	$T_C(\text{MAX.})+10$		
06-07	2	Temp Low Warning	$T_C(\text{MIN.})+10$		
08-09	2	Voltage High Alarm	$V_{CC}+5\%$	Volt	
10-11	2	Voltage Low Alarm	$V_{CC}-5\%$		
12-13	2	Voltage High Warning	$V_{CC}+3\%$		
14-15	2	Voltage Low Warning	$V_{CC}-3\%$		
16-17	2	Bias High Alarm	$I_{OP} * 2 + 35$	mA	2
18-19	2	Bias Low Alarm	$I_{OP} - 13$		
20-21	2	Bias High Warning	$I_{OP} * 2 + 30$		
22-23	2	Bias Low Warning	$I_{OP} - 8$		
24-25	2	TX Power High Alarm	P+3	dBm	3
26-27	2	TX Power Low Alarm	P-3		
28-29	2	TX Power High Warning	P+2		
30-31	2	TX Power Low Warning	P-2		
32-33	2	RX Power High Alarm	$P_0 + 3$	dBm	4
34-35	2	RX Power Low Alarm	$P_S - 2$		
36-37	2	RX Power High Warning	$P_0 + 2$		
38-39	2	RX Power Low Warning	P_S		
40-45	16	Reversed			
56-91	36	External Calibration Constants			
92-94	3	Reversed			
95	1	Checksum			5
96-97	2	Real Time Temperature			
98-99	2	Real Time Supply Voltage			
100-101	2	Real Time Tx Bias Current			
102-103	2	Real Time Tx Optical Power			
104-105	2	Real Time Rx Received Power			
106-109	4	Reserved			
110	1	Optional Status/ Control Bits			6
111	1	Reserved			
112-119	8	Optional Set of Alarm and Warning			7

Notes:

- 1) T_C : Case Operating temperature.
- 2) I_{OP} : Operating current at room temperature. The min. setting current is 0 mA.
- 3) P: Operating optical power of transmitter at room temperature.
- 4) P_0 : Overload optical power of receiver.

P_S : Sensitivity optical power of receiver.

5) Byte 95 contains the low order 8bits of sum of bytes 0-94.

6)

State/ Control Bits

Byte	Bit	Name	Description
110	7	Tx Disable State	Digital state of the Tx disable input pin
110	6	Soft Tx Disable	Read/ Write bit that allow software disable of laser
110	5	Reserved	
110	4	Rate Select tate	NA
110	3	Soft Rate Select	NA
110	2	Tx Fault	Digital state of the Tx fault output pin
110	1	LOS	Digital state of the LOS output pin.
110	0	Data_Ready_Bar	NA

7)

Optional Set of Alarm and Warning

Byte	Bit	Name	Description
112	7	Temp High Alarm	Set when internal temperature exceeds high alarm level
112	6	Temp Low Alarm	Set when internal temperature is below low alarm level
112	5	Vcc High Alarm	Set when internal supply voltage exceeds high alarm level
112	4	Vcc Low Alarm	Set when internal supply voltage is below low alarm level
112	3	Tx Bias High Alarm	Set when Tx Bias current exceeds high alarm level
112	2	Tx Bias Low Alarm	Set when Tx Bias current is below low alarm level
112	1	Tx Power High Alarm	Set when Tx output power exceeds high alarm level
112	0	Tx Power Low Alarm	Set when Tx output power is below low alarm level
113	7	Rx Power High Alarm	Set when received power exceeds high alarm level
113	6	Rx Power Low Alarm	Set when received power is below low alarm level
113	5-0	Reserved	
116	7	Temp High Warning	Set when internal temperature exceeds high warning level
116	6	Temp Low Warning	Set when internal temperature is below low warning level
116	5	Vcc High Warning	Set when internal supply voltage exceeds high warning level
116	4	Vcc Low Warning	Set when internal supply voltage is below low warning level
116	3	Tx Bias High Warning	Set when Tx Bias current exceeds high warning level
116	2	Tx Bias Low Warning	Set when Tx Bias current is below low warning level
116	1	Tx Power High Warning	Set when Tx output power exceeds high warning level
116	0	Tx Power Low Warning	Set when Tx output power is below low warning level
117	7	Rx Power High Warning	Set when received power exceeds high warning level
117	6	Rx Power Low Warning	Set when received power is below low warning level
117	5-0	Reserved	

Digital Diagnostic Monitor Accuracy

Parameter	Typical Value	Note
Transceiver Temperature	± 3	1
Power Supply Voltage	$\pm 3\%$	2
TX Bias Current	$\pm 10\%$	
TX Optical Power	$\pm 1.5\text{dB}$	
RX Optical Power	$\pm 3\text{dB}$	3

Notes:

- 1) Temperature is measured internal to the transceiver.
- 2) Voltage is measured internal to the transceiver.
- 3) Valid from -34dBm to -10 dBm.

Regulatory Compliance

Test Item	Reference	Qty'	Evaluation
(#1) Electromagnetic Interference EMC	FCC Class B EN 55022 Class B CISPR 22	5	(1) Satisfied with electrical characteristics of product spec. (2) No physical damage
(#2) Immunity : Radio Frequency Electromagnetic Field	EN 61000-4-3 IEC 1000-4-3	5	
(#3) Immunity : Electrostatic Discharge to the Duplex SC Receptacle	EN 61000-4-2 IEC 1000-4-2 IEC 801.2	5	
(#4) Electrostatic Discharge to the Electrical Pins	MIL-STD-883C Method 3015.4 EIAJ#1988.3.2B Version 2, Machine model	5	



Ordering information for SFP modules

LCP-155D4 X ₁ X ₂ X ₃ X ₄			
X₁: Link Budget R: 29dB V: 33dB U: 36dB		X₂:	Wavelength
			47: Single-mode 1470nm
			49: Single-mode 1490nm
			51: Single-mode 1510nm
			53: Single-mode 1530nm
			55: Single-mode 1550nm
			57: Single-mode 1570nm
			59: Single-mode 1590nm
			61: Single-mode 1610nm
X₃: RoHS Compliance R: RoHS Compliant		X₄: Temperature Blank: -5 to +70 degree C H: -10 to +85 degree C T: -40 to +85 degree C	

Revision History

Rev	Date	Contents
0A	Jun., 2006	First release
0B	Aug., 2006	Add -10 to +85 and -40 to +85 degree C P/Ns in data sheet
0C	Aug., 2006	1. Update A2h design 2. Changed the wavelength range
0D	Nov., 2006	Add LCP-155D4UxxR series products in data sheet.
0E	Dec., 2006	To change the supply current from 300mA to 380mA for LCP-155D4xxxRH and LCP-155D4xxxRT.
0F	Jun., 2007	To add note 3 for Digital Diagnostic Monitor Accuracy. To modify the Byte 59, 66 and 67 of the A0h EEPROM.