

**EU3512-3X
Environmental
Enclosure
and
Light Duty Wall Mount**

**Installation/
Operation Manual**

C2428M-A (2/01)

CONTENTS

Section	Page
IMPORTANT SAFEGUARDS AND WARNINGS	3
DESCRIPTION	4
INSTALLATION	4
INSTALL WALL MOUNT	4
ENCLOSURE INSTALLATION	4
CAMERA AND LENS INSTALLATION	5
OPERATION	6
MAINTENANCE	6
SPECIFICATIONS	7
WARRANTY AND RETURN INFORMATION	8

LIST OF ILLUSTRATIONS

Figure	Page
1 Wiring Diagram	5
2 Enclosure Dimension Drawing	7
3 Mount Dimension Drawing	7

LIST OF TABLES

Table	Page
A Heater and Defroster Wiring Distances	5
B 24 VAC Wiring Distances	6
C Video Coaxial Cable Wiring Distances	6

IMPORTANT SAFEGUARDS AND WARNINGS

Prior to installation and use of this product, the following WARNINGS should be observed.

1. Installation and servicing should only be done by qualified service personnel and conform to all local codes.
2. Unless the unit is specifically marked as a NEMA Type 3, 3R, 3S, 4, 4X, 6 , or 6P enclosure, it is designed for indoor use only and it must not be installed where exposed to rain and moisture.
3. Only use replacement parts recommended by Pelco.
4. After replacement/repair of this unit's electrical components, conduct a resistance measurement between line and exposed parts to verify the exposed parts have not been connected to line circuitry.
5. The installation method and materials should be capable of supporting four times the weight of the enclosure, pan/tilt, camera and lens combination.

The product and/or manual may bear the following marks:



This symbol indicates that dangerous voltage constituting a risk of electric shock is present within this unit.



This symbol indicates that there are important operating and maintenance instructions in the literature accompanying this unit.

CAUTION:
RISK OF ELECTRIC SHOCK. DO NOT OPEN.

Please thoroughly familiarize yourself with the information in this manual prior to installation and operation.

DESCRIPTION

The EU3512-3X is an indoor/outdoor light-duty camera enclosure and light-duty wall mount. The enclosure includes a sun shroud and 230 VAC heater and defroster. The wall mount has an adjustable tilt table allowing for mechanical positioning of the enclosure.

Install the EU3512-3X to any wall or vertical surface, capable of supporting up to 20 pounds (9 kg).

INSTALLATION

INSTALL WALL MOUNT

Perform the following steps to install the mount:

1. Determine the mounting location. Use the flanged end of the mount as a template and mark the fastener hole positions onto the mounting surface.
 - Mounting to a **solid surface** mark the three fastener holes
 - Mounting to a **wall stud** mark the two center fastener holes
2. Set the mount to the side and prepare the holes for the fasteners.
3. Position the mount over the mounting holes and secure with fasteners.
 - Mounting to a **solid surface**, secure with three .25-inch diameter fasteners (not supplied)
 - Mounting to a **wall stud**, secure with one .3125-inch fastener and one .25-inch fastener (not supplied)

If you install the mount outdoors, seal the fastener holes with an appropriate sealant to prevent water damage. Apply the sealant between the mount and the mounting surface.

ENCLOSURE INSTALLATION

1. Unlatch and open the lid of the enclosure.
2. Remove the camera sled from the rail of the enclosure.
 - a. Loosen the screws that hold the camera sled in place.
 - b. Slide the sled forward so it can be lifted out over the screws.
 - c. Remove the sled.
 - d. Remove the parts tied to the sled.
3. If you are wiring the enclosure with cable, remove the glands and nuts from the parts bag and install them in the bottom of the enclosure. If you are wiring the enclosure with conduit, do not install the glands.
4. Attach the base of the enclosure to the mount tilt table with the two 1/4-20 x .50-inch screws (provided).
5. Loosen the cap nut located on the support bracket of the tilt table and adjust the tilt table to the desired direction. Tighten the cap nut. Loosen the two screws on the tilt table and adjust it for the desired angle. Tighten the screws.

CAMERA AND LENS INSTALLATION

1. To install the camera and lens onto the enclosure sled:
 - a. Extend the lens to the maximum length.
 - b. Position the camera and lens so that they do not extend beyond the track.
 - c. Fasten the camera and lens to the sled with the two, 1/4-20 x .375 Phillips screws supplied.

The edges of the sled are bent, one side up and the other side down. One side of the sled has a wide lip and the other side has a narrow lip. In a typical installation, you mount the camera so that the holes in the wide lip of the sled fit over the sled mounting screws. However, you can elevate the sled if you are installing a camera with a low optical centerline or a camera with a large diameter lens. To elevate the sled, flip the sled over so that the holes in the narrow lip of the sled fit over the sled mounting screws.

2. Install the sled and camera assembly into the enclosure. Slide the sled over the mounting screws and lightly tighten the screws.
3. Pull the power wires and cables through the glands or conduit into the enclosure. Refer to Tables A and B to determine the size of the power wire to use. Refer to Table C for the type of video coaxial cable to use.
4. Connect the cables for power and video to the camera.
5. Refer to Figure 1 to wire the heater and defroster to power.
6. If the camera lens is adjustable, extend the lens to its maximum length; verify that the end of the lens is a minimum of .50-inch from the enclosure window.
7. Tighten the screws that secure the sled to the enclosure.
8. Adjust the glands for a tight fit around the cables.
9. Close the enclosure lid, and latch.
10. Adjust the camera focus and iris if necessary. If you need to adjust the focus and iris manually, open the enclosure lid, adjust the focus and iris, and close the enclosure lid.

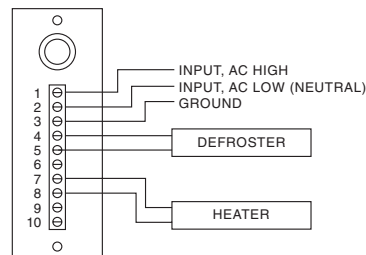

Figure 1. Wiring Diagram

Table A. Heater and Defroster Wiring Distances

The following cable sizes are the minimum recommended for use with the heater and defroster.

Input Voltage	Power Consumption	Cable Size	Cable Distance
230 VAC at 50 Hz	13 watts	20 AWG (0.5 mm ²)	20,045 ft (6,109 m)
		18 AWG (1.0 mm ²)	31,890 ft (9,720 m)
		16 AWG (1.5 mm ²)	50,612 ft (15,426 m)
		14 AWG (2.5 mm ²)	80,738 ft (24,608 m)



CAUTION: When using a single power source for both camera and accessories, consider the camera power consumption when determining the wire gauge. Table A does not include camera power.

Table B. 24 VAC Wiring Distances

The following are the recommended maximum distances for 24 VAC applications and are calculated with a 10-percent voltage drop. (Ten percent is generally the maximum allowable voltage drop for AC-powered devices.)

EXAMPLE: An enclosure that requires 80 vA and is installed 35 feet (10 m) from the transformer would require a minimum wire gauge of 20 Awg.

NOTE: Distances are calculated in feet; values in parentheses are meters.

		Wire Gauge					
		20 (0.5 mm ²)	18 (1.0 mm ²)	16 (1.5 mm ²)	14 (2.5 mm ²)	12 (4.0 mm ²)	10 (6.0 mm ²)
Total vA consumed	10	283 (86)	451 (137)	716 (218)	1142 (348)	1811 (551)	2880 (877)
	20	141 (42)	225 (68)	358 (109)	571 (174)	905 (275)	1440 (438)
	30	94 (28)	150 (45)	238 (72)	380 (115)	603 (183)	960 (292)
	40	70 (21)	112 (34)	179 (54)	285 (86)	452 (137)	720 (219)
	50	56 (17)	90 (27)	143 (43)	228 (69)	362 (110)	576 (175)
	60	47 (14)	75 (22)	119 (36)	190 (57)	301 (91)	480 (146)
	70	40 (12)	64 (19)	102 (31)	163 (49)	258 (78)	411 (125)
	80	35 (10)	56 (17)	89 (27)	142 (43)	226 (68)	360 (109)
	90	31 (9)	50 (15)	79 (24)	126 (38)	201 (61)	320 (97)
	100	28 (8)	45 (13)	71 (21)	114 (34)	181 (55)	288 (87)

Maximum distance from transformer to load

Table C. Video Coaxial Cable Wiring Distances

Cable Type*	Maximum Distance
RG59/U	750 ft (229 m)
RG6/U	1,000 ft (305 m)
RG11/U	1,500 ft (457 m)

* Minimum cable requirements:
 75 ohms impedance
 All-copper center conductor
 All-copper braided shield with 95% braid coverage

OPERATION

The enclosure has a thermostatically controlled heater, that is set to turn on at 50°F (10°C) and turn off at 80°F (27°C). The defroster operates continuously.

MAINTENANCE

Regularly scheduled maintenance prolongs the operational life and appearance of the equipment. Clean the window regularly with a soft cloth using a mild, nonabrasive detergent and water to maintain picture clarity.

SPECIFICATIONS

ENCLOSURE

- Camera Mounting:** Multiple holes on adjustable camera sled; camera sled mounts in threaded strip for easier removal and can be inverted for additional camera elevation.
- Camera and Lens Size:** Accommodates camera and lens combinations (including BNC connector) 2.87 (W) x 3.00 (H) x 9.00 (L) inches (7.28 x 7.62 x 22.86 cm)
- Viewing Window:** Lexan®, .187-inch (4.75 mm) thick, optically clear, impact-resistant, MR5 coated (U.L. 94HB rated).
- Viewing Area:** 2.25 (H) x 2.63 (W) inches (5.71 x 6.68 cm)
- Cable Entry:** Two PG13.5 compression glands on the bottom of the enclosure; maximum cable diameter 0.47-inch (1.19 cm).
- Cable Entry Holes:** .875-inch diameter; will accept 0.50-inch (1.27 cm) conduit fitting when compression gland is removed.
- Latch:** Link-lock, stainless steel, can be secured with padlock (not supplied).

GENERAL

- Construction:** Extruded and die-cast aluminum body
- Dimensions:** Refer to Figure 2
- Ratings:** EMA 4, IP 66
- Environment:** 10° to 120°F (-23° to 49°C)
- Weight:** 4 lb (1.75 kg)

MOUNT

- Pan Adjustment:** 360°
- Tilt Adjustment:** ± 75°
- Construction:** Die cast aluminum
- Mounting Arm:** Aluminum
- Tilt Table and Support Bracket:** Aluminum
- Finish:** Gray polyester powder coat
- Maximum Load:** 20 lb (9 kg)
- Dimensions:** See Figure 3
- Unit Weight:** 2 lb (.91 kg)
- Environment:** Indoor/outdoor

(Design and product specifications subject to change without notice.)

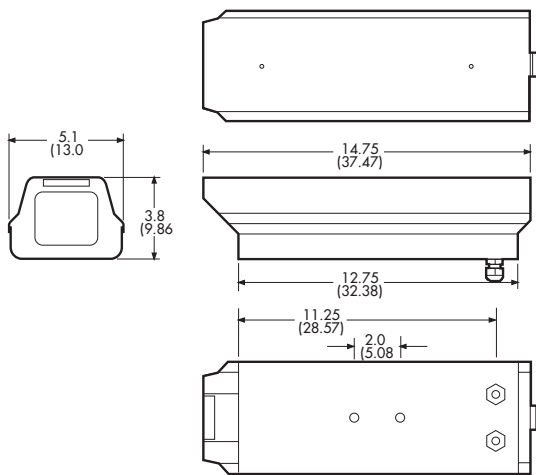

NOTE: VALUES IN PARENTHESES ARE CENTIMETERS;
ALL OTHERS ARE IN INCHES.

Figure 2. Enclosure Dimension Drawing

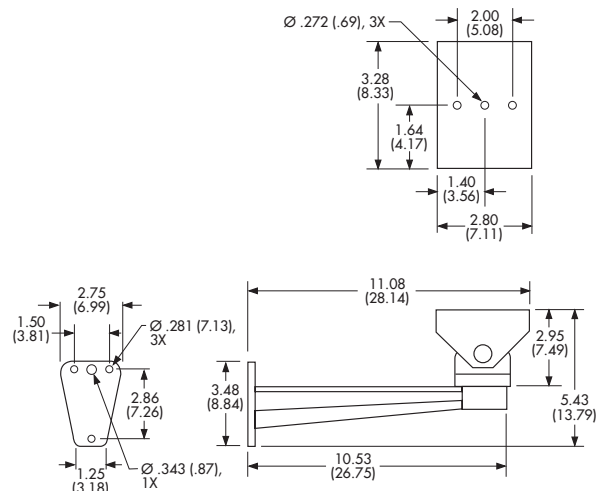

NOTE: VALUES IN PARENTHESES ARE CENTIMETERS;
ALL OTHERS ARE IN INCHES.

Figure 3. Mount Dimension Drawing

PRODUCT WARRANTY AND RETURN INFORMATION

WARRANTY

Pelco will repair or replace, without charge, any merchandise proved defective in material or workmanship **for a period of one year** after the date of shipment.

Exceptions to this warranty are as noted below:

- Five years on FT/FR8000 Series fiber optic products.
- Three years on Genex® Series products (multiplexers, server, and keyboard).
- Three years on Camclosure® and fixed camera models, except the CC3701H-2, CC3701H-2X, CC3751H-2, CC3651H-2X, MC3651H-2, and MC3651H-2X camera models, which have a five-year warranty.
- Two years on standard motorized or fixed focal length lenses.
- Two years on Legacy®, CM6700/CM6800/CM9700 Series matrix, and DF5/DF8 Series fixed dome products.
- Two years on Spectra®, Esprit®, ExSite™, and PS20 scanners, including when used in continuous motion applications.
- Two years on Esprit® and WW5700 Series window wiper (excluding wiper blades).
- Eighteen months on DX Series digital video recorders, NVR300 Series network video recorders, and Endura™ Series distributed network-based video products.
- One year (except video heads) on video cassette recorders (VCRs). Video heads will be covered for a period of six months.
- Six months on all pan and tilts, scanners or preset lenses used in continuous motion applications (that is, preset scan, tour and auto scan modes).

Pelco will warrant all replacement parts and repairs for 90 days from the date of Pelco shipment. All goods requiring warranty repair shall be sent freight prepaid to Pelco, Clovis, California. Repairs made necessary by reason of misuse, alteration, normal wear, or accident are not covered under this warranty.

Pelco assumes no risk and shall be subject to no liability for damages or loss resulting from the specific use or application made of the Products. Pelco's liability for any claim, whether based on breach of contract, negligence, infringement of any rights of any party or product liability, relating to the Products shall not exceed the price paid by the Dealer to Pelco for such Products. In no event will Pelco be liable for any special, incidental or consequential damages (including loss of use, loss of profit and claims of third parties) however caused, whether by the negligence of Pelco or otherwise.

The above warranty provides the Dealer with specific legal rights. The Dealer may also have additional rights, which are subject to variation from state to state.

If a warranty repair is required, the Dealer must contact Pelco at (800) 289-9100 or (559) 292-1981 to obtain a Repair Authorization number (RA), and provide the following information:

1. Model and serial number
2. Date of shipment, P.O. number, Sales Order number, or Pelco invoice number
3. Details of the defect or problem

If there is a dispute regarding the warranty of a product which does not fall under the warranty conditions stated above, please include a written explanation with the product when returned.

Method of return shipment shall be the same or equal to the method by which the item was received by Pelco.

RETURNS

In order to expedite parts returned to the factory for repair or credit, please call the factory at (800) 289-9100 or (559) 292-1981 to obtain an authorization number (CA number if returned for credit, and RA number if returned for repair).

All merchandise returned for credit may be subject to a 20% restocking and refurbishing charge.

Goods returned for repair or credit should be clearly identified with the assigned CA or RA number and freight should be prepaid. Ship to the appropriate address below.

If you are located within the continental U.S., Alaska, Hawaii or Puerto Rico, send goods to:

Service Department
Pelco
3500 Pelco Way
Clovis, CA 93612-5699

If you are located outside the continental U.S., Alaska, Hawaii or Puerto Rico and are instructed to return goods to the USA, you may do one of the following:

If the goods are to be sent by a COURIER SERVICE, send the goods to:

Pelco
3500 Pelco Way
Clovis, CA 93612-5699 USA

If the goods are to be sent by a FREIGHT FORWARDER, send the goods to:

Pelco c/o Expeditors
473 Eccles Avenue
South San Francisco, CA 94080 USA
Phone: 650-737-1700
Fax: 650-737-0933

REVISION HISTORY

Manual #	Date	Comments
C2428M	01/01	Original version.
C2428M-A	2/01	Removed reference to 120 VAC.