

READ AND UNDERSTAND THESE INSTRUCTIONS BEFORE INSTALLING FIXTURE
 This fixture is intended for installation in accordance with the National Electrical Code and local regulations. To assure full compliance with local codes and regulations, check with your local electrical inspector before installation. To prevent electrical shock, turn off electricity at fuse box before proceeding.
 Retain these instructions for maintenance reference.

INSTRUCTION SHEET NO.
IS:1102TF
 0496 Page 1 of 4

**INSTALLATION OF PRE-WIRED COMPACT
 FLUORESCENT EMERGENCY LIGHTING DOWNLIGHTS**

120 VOLTS--(1102T18T1EM
 277 VOLTS--(1102T18T2EM

120 VOLTS--(1102T26F1EM
 277 VOLTS--(1102T26F2EM

**IMPORTANT SAFEGUARDS
 READ AND FOLLOW ALL SAFETY INSTRUCTIONS**

When using electrical equipment, basic safety precautions should always be followed, including the following:

1. Do not install insulation within 3 inches of fixtures sides or wiring compartment, nor above fixture in such a manner to entrap heat.
2. Turn off AC power before proceeding.
3. Be sure all electrical connections are complete and the junction box is closed before Unit Connector (located in the SWITCH/INDICATOR LIGHT BOX) is connected.
4. Do not use outdoors.
5. Do not let power supply cords touch hot surfaces.
6. Do not mount near gas or electric heaters.
7. Use caution when servicing batteries. Do not incinerate or mutilate; may burst or release toxic material. Do not short circuit; may cause burns. Battery acid can cause burns to skin and eyes. If acid is spilled on skin or in eyes, flush acid with fresh water and contact a physician immediately.
8. Equipment should be mounted in locations and at a height where it will not readily be subjected to tampering by unauthorized personnel.
9. The use of accessory equipment not recommended by the manufacturer may cause an unsafe condition.
10. Do not use this equipment for other than intended use.
11. This unit has more than one power supply connection point. To reduce the risk of electrical shock—disconnect both normal and emergency power supplies before servicing.
12. Before servicing, to prevent electric shock, make sure the unit connector of the EMERGENCY PACK (located in the switch/indicator light box) is disconnected, make certain that the switched (if the fixture is switched) and the unswitched line to the EMERGENCY PACK is turned off at the fuse box. Servicing should be performed by qualified service personnel only.

SAVE THESE INSTRUCTIONS

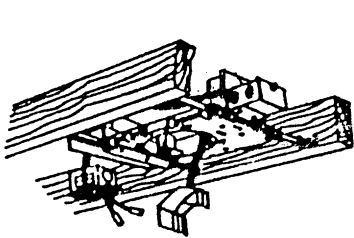

FIG.A
 A. FRAME - IN

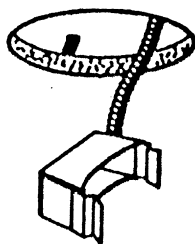

FIG.B
 B. CLOSE - IN

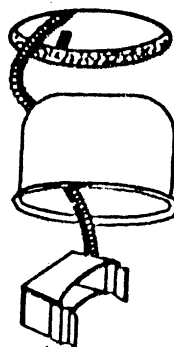

FIG.C
 C. PULL - THRU

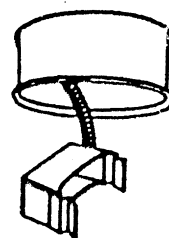

FIG.D
 D. PUSH - UP



FIG.E
 E. SNAP - IN

LIGHTOLIER®

FALL RIVER, MASSACHUSETTS, 02720
 MONTREAL, QUEBEC, CANADA

A. FRAME-IN

Fasten MOUNTING FRAME to wood joist. Line up bottom edge of ADJUSTABLE MOUNTING BAR with bottom of wood joist (Fig. 5). Wire to supply leads. (For Cable, use built-in Cable Clamp in J-Box.)

NOTE: 1. ADJUSTABLE MOUNTING BARS are pre-assembled on long side of MOUNTING FRAME for rigidity and ease of installation, Fig. 5. The MOUNTING BARS must be removed and installed on narrow side of MOUNTING FRAME if installed between joist on 16" spacing, Fig. 6.

2. MOUNTING BARS can be extended to 24"; the MOUNTING FRAME can be mounted off-center.

3. For suspended ceilings, make certain that bottom of MOUNTING FRAME is no higher than 1" above ceiling line, Fig. 7.

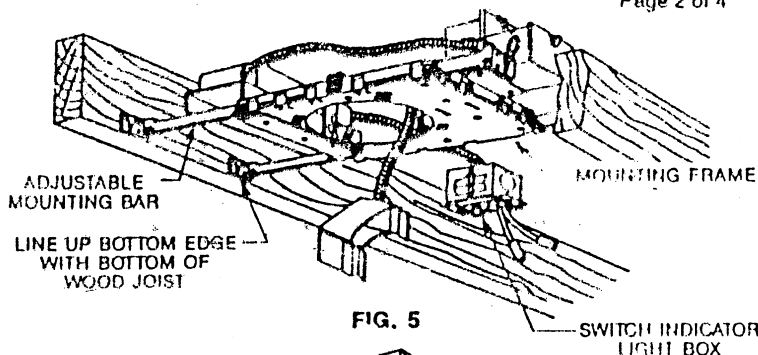

FIG. 5

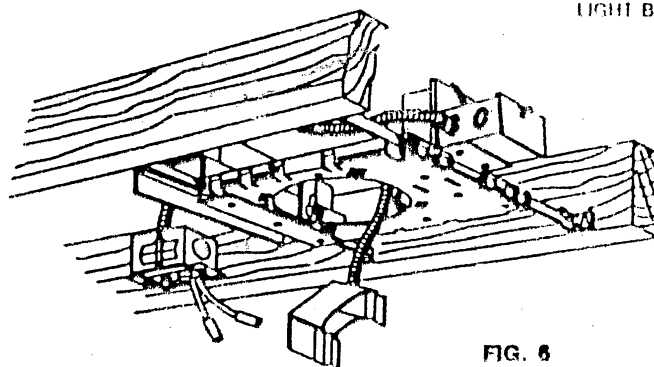

FIG. 6

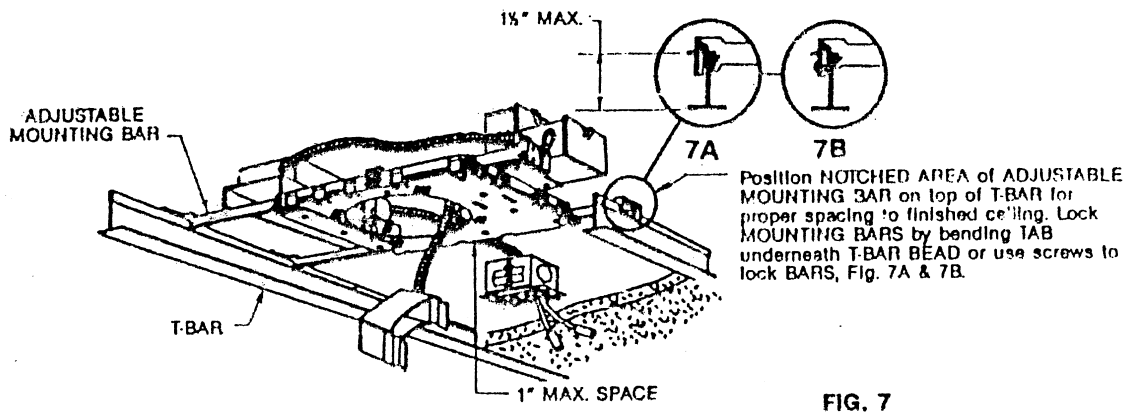
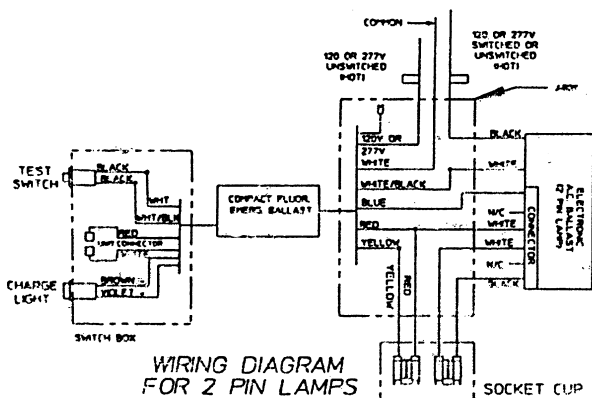

FIG. 7

WIRING:

1. Make sure AC power is off at the fuse box.
2. AC BALLAST AND EMERGENCY BALLAST must be fed from the same branch circuit.
3. In switched fixtures the EMERGENCY BALLAST must be connected ahead of any local switching.
4. This fixture is prewired for 120V or 277V. Check marking on fixture before making connections in Junction Box. See wiring diagram (Fig. 8).
5. Be sure all electrical connections are made and the JUNCTION BOX is closed before connecting UNIT CONNECTOR in SWITCH/INDICATOR LIGHT BOX.



WIRING DIAGRAM FOR 2 PIN LAMPS

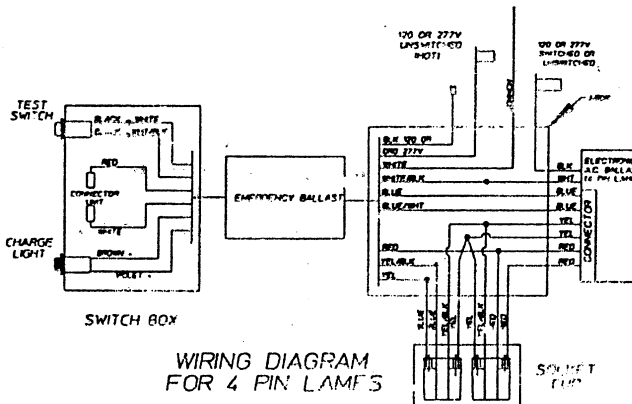

WIRING DIAGRAM FOR 4 PIN LAMPS

B. CLOSE-IN

1. install plasterboard or other dry tape ceiling, as required. Hole in board can be cut either on the floor or after the board is nailed to the ceiling, using MOUNTING FRAME opening as cutting guide. (Make sure ROTO CLIPS are rotated out of hole area).
2. Cut hole in ceiling for SWITCH/INDICATOR LIGHT BOX in a convenient location to the side or end of frame (Fig. 9). The recommended hole size is 2" x 3 1/4".
3. Close-in ceiling.
4. Pull down SWITCH/INDICATOR LIGHT BOX (Fig. 9) and clamp on to ceiling by tightening SCREWS on side of box (Fig. 9).
5. Connect UNIT CONNECTOR in SWITCH BOX (Fig. 9).
6. Fasten TRIM PLATE to SWITCH BOX with NUT provided (Fig. 10).

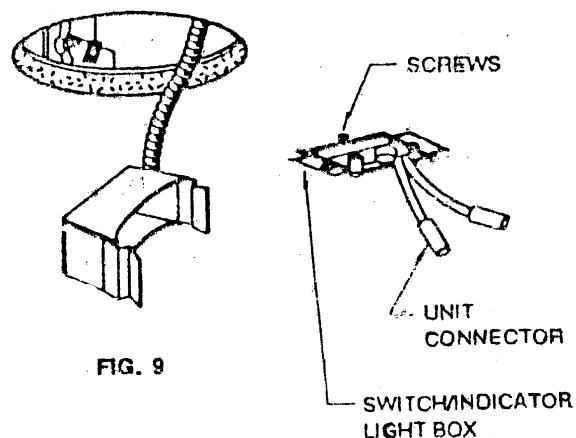

FIG. 9

C. PULL THRU

D. PUSH-UP

E. SNAP-IN

SEE SEPARATE
REFLECTOR TRIM
INSTRUCTION
SHEET

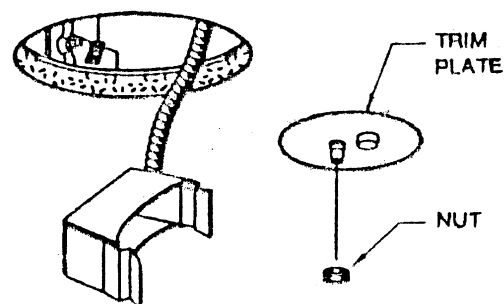

FIG. 10

F. OPERATION

When AC power is applied, the charging indicator light is illuminated, indicating that the battery is being charged. When the power fails, the emergency lighting ballast automatically switches to emergency operation, keeping one lamp on reduced output for 90 minutes.

G. MAINTENANCE

Although no routine maintenance is required to keep the emergency lighting ballast functional, it should be checked periodically to ensure that it is working. The following schedule is recommended:

1. Visually inspect the charging indicator light monthly. It should be illuminated.
2. Test the emergency operation of fixture once every 3 months. One lamp should operate at reduced output.
3. Conduct a 90 minute discharge test once a year. One lamp should operate at reduced output for 90 minutes.

H. EMERGENCY BALLAST REPLACEMENT

Make sure AC power is off at fuse box. (For accessible and non-accessible ceiling.)

1. Remove REFLECTOR TRIM (see Reflector Trim Instruction Sheet).
2. Remove TRIM PLATE by removing LOCKNUT; disconnect UNIT CONNECTOR, loosen SCREW on side of SWITCH BOX and slip SWITCH BOX onto the ceiling (Fig. 11).
3. Loosen THUMB NUT and rotate BRACKET away from EMERGENCY BALLAST ASSEMBLY (Fig. 11).
4. Detach EMERGENCY BALLAST from the MOUNTING PLATE and pull down through the frame opening (Fig. 12).
5. Unwire and disassemble defective EMERGENCY BALLAST from SWITCH BOX and JUNCTION BOX.
6. Replace with new EMERGENCY BALLAST. Follow wiring diagram and instruction procedure provided in this Instruction Sheet.

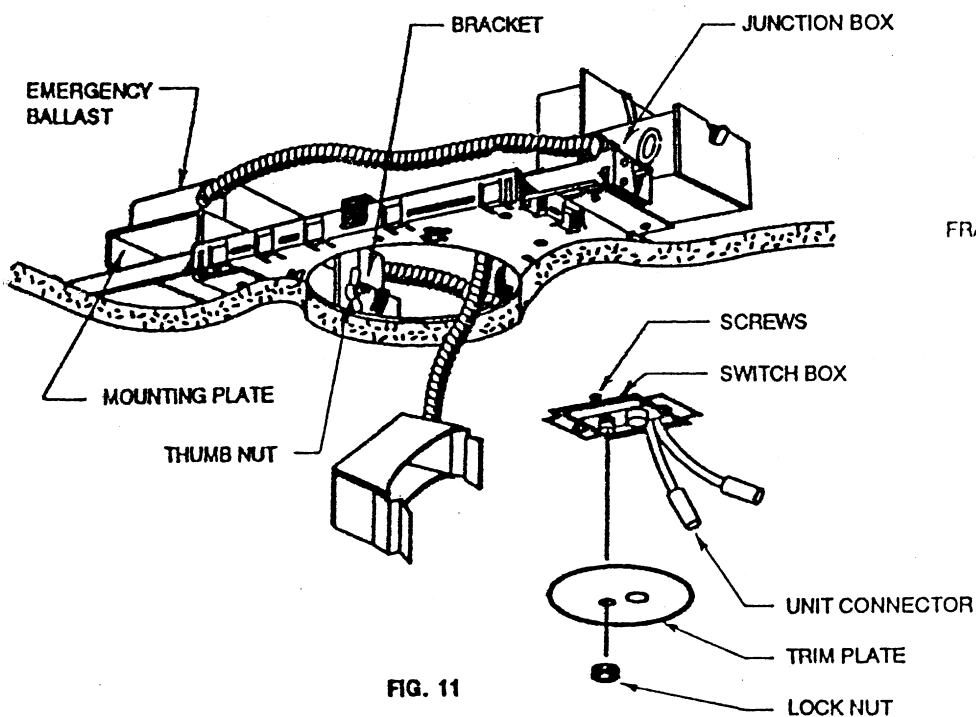

FIG. 11

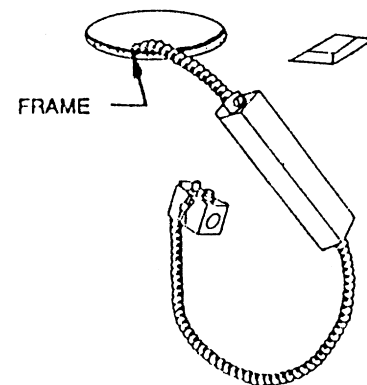
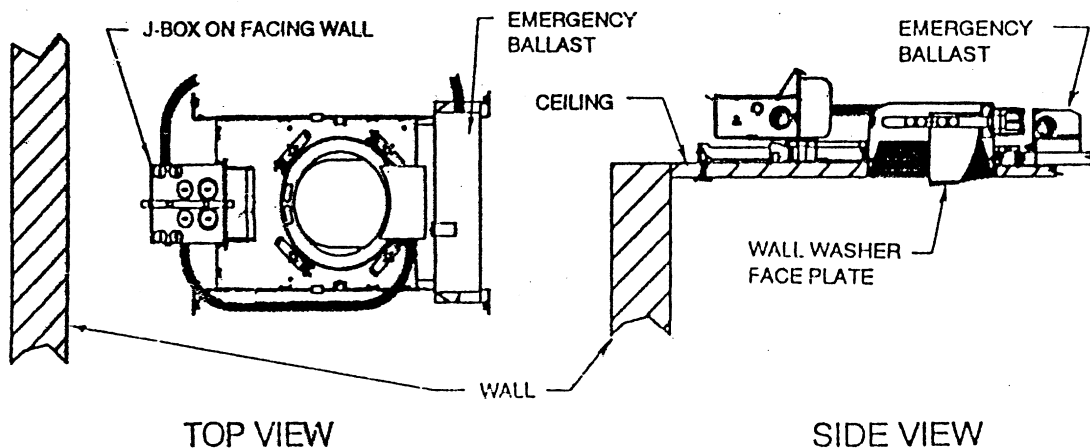

FIG. 12

I. FRAME-IN KIT INSTALLATION WHEN USING WALL WASHER TRIM (1135T)



TOP VIEW

SIDE VIEW