

KOP-FLEX, INC., P.O. BOX 1696, BALTIMORE MARYLAND 21203, 410-768-2000

KOP-FLEX CANADA, LTD., 19 METEOR DRIVE, REXDALE, ONTARIO, CANADA M9W-1A3, 416-675-7144

	<p>⚠ WARNING</p> <p>High voltage and rotating parts may cause serious or fatal injury.</p> <p>Turn off power to install or service.</p> <p>Operate with guards in place.</p> <p>Read and follow all instructions in this manual.</p>	
---	---	---

⚠ WARNING

Because of the possible danger to person(s) or property from accidents which may result from the improper use or unapproved modification of the product, this product must be installed, maintained, and operated in accordance with the procedures, standards and engineering information specified in the product brochures and illustrations. To assure safe operation, this product should be inspected in accordance with the instructions described in this form. Proper guards and other suitable safety devices or procedures as may be desirable, or as may be specified in safety codes, should be installed by the user. Guards and other safety equipment are not provided, nor are they the responsibility of Emerson Power Transmission.

1.0 General Instructions

Prior to installation, inspect the coupling for any signs of damage that may have occurred during shipment. Check that all parts are on hand and are as ordered.

⚠ WARNING

ONLY BOLTS AND NUTS SUPPLIED BY KOP-FLEX ARE TO BE USED.

Components should be cradled or supported during handling to avoid damage and should be wrapped for protection. Flanges and pilot surfaces should be kept free of nicks and burrs.

Read all of the installation instructions and review the procedure before the actual coupling installation.

2.0 Installation of Coupling Hubs - Keyed Mounting

- 2.1 Check the hub bore and shaft for nicks and burrs, dress if necessary. Make sure that the bore and shaft are clean.
- 2.2 For tapered bores, check the fit of the bore to the shaft.
- 2.3 Keys must be precisely fitted to the keyways in the shaft and hub. Each key should have a tight fit on the sides with a slight clearance on top. To maintain dynamic balance, the keys should fill the keyways exactly and not be too short or too long.
- 2.4 Clean the hub bore and shaft. For straight bores, proceed to step 2.6. For taper bores, mount the hub handtight on the shaft and lightly rap it with a soft mallet to establish the initial line-to-line fit. This is the START position. With a depth gauge, measure the amount the hub overhangs the shaft end and record this value. See Figure 1.

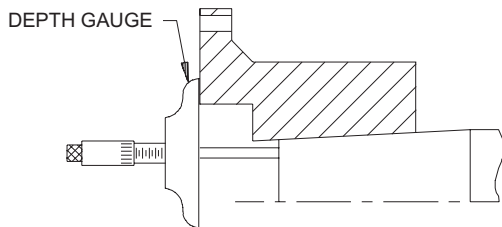

Figure 1. Measuring Hub Overhang

2.5 Taper Bores Only: A recommended method to measure the hub advance is to install a split collar on the shaft, away from the hub by the amount of the specified advance. Use feeler gauges for accurate spacing. See Figure 2. The amount of hub draw is dependent upon the desired interference and taper angle as specified by the machine manufacturer or as given on the coupling drawing. See Figure 3.

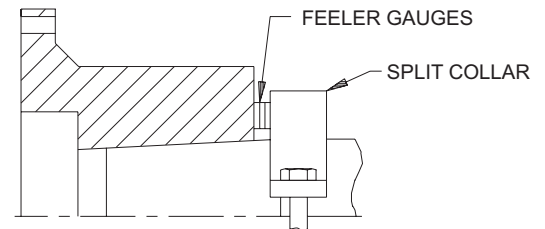

Figure 2. Using Split Collar to Set Advance

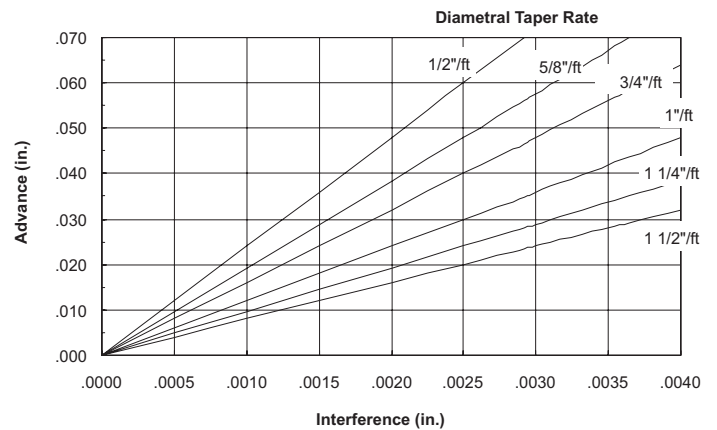

Figure 3. Hub Advance vs. Interference Chart

2.6 Heat the hub to expand the bore; DO NOT allow the hub temperature to exceed 600°F (300°C). DO NOT apply an open flame to any part of the coupling, an oven is recommended.

⚠ WARNING

To avoid the risk of explosion, fire, or damage to the coupling and equipment, and/or injury to personnel, do not use an open flame or oil bath to expand the hub. If heat is used at any time for installation, DO NOT allow the hub temperature to exceed 600°F (300°C).

2.7 Place the hub in the proper position on the shaft. Hold the hub in place as it cools. For taper bores, verify the hub advance (see Figures 1 and 2) and install the shaft retaining nut. Remove the split collar from the shaft.



3.0 Alignment

Note: Exact values and procedures for aligning equipment are normally specified by the equipment manufacturers. Good initial alignment to the minimum possible values will promote optimum machinery performance and eliminate potential operating problems. After securely tightening the foundation bolts, the hub separation and alignment should be rechecked and adjusted if necessary.

The coupling alignment should be checked periodically. Even when a coupling is well aligned at installation, subsequent settling of foundations, shifting of equipment, etc., may cause the alignment to deteriorate.

Offset and Angular Alignment

3.1 Reverse dial indication or optical methods of alignment (such as laser) are recommended. A cold alignment and a hot check (with corrections if necessary) are required. The hub flange OD can be used to mount the alignment equipment. The hub flange OD is machined to be concentric to the coupling bore and can be used as the reference diameter.

3.2 The maximum recommended operating misalignment is:

- 0.10 degrees per disc pack
- (0.0035 in/in TIR equivalent parallel offset)

Important: Total misalignment is the combination of equipment parallel offset and angular misalignment.

Note that improving the alignment below these values will promote optimum machinery performance.

Axial Alignment

3.3 Align the hubs until they are at the correct hub separation. The hub separation is measured from the two flange faces, not from the pilot face.

$$\text{Hub Separation} = \text{Center Assembly Length}$$

4.0 Final Assembly (KD2 and KD20)

4.1 After correctly installing both hubs, use the separate collapsing screws to pull the adapter rings toward the center of the pre-assembled center section. This is made up of the spacer, two disc packs, and two adapter rings.

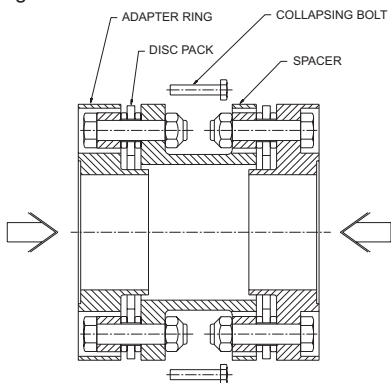

Figure 4. Collapsing center section

4.2 For each side of the center section, insert the collapsing bolts through the spacer clearance holes into tapped holes in the ring (see Figure 4).

4.3 Tighten them evenly and collapse the disc packs equally, only enough to allow the center assembly to drop into place (see Figure 5).

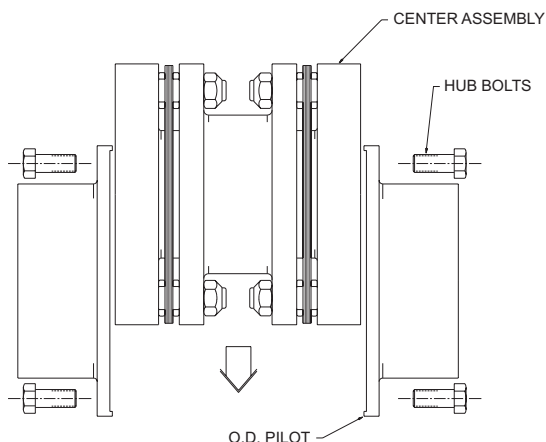

Figure 5. Installing center section.

4.4 Put the center assembly (spacer and rings) between the rigid hubs, engage the pilot, and install the hub bolts in one hub flange.

4.5 Release all the collapsing bolts, and install the hub flange bolts on the second rigid hub flange.

4.6 Torque the hub flange bolts to the value specified in Table 1.

Coupling Size	Tightening Torque (Lightly Oiled)			
	KD2		KD20	
	ft-lb	N-m	ft-lb	N-m
103	8	10	--	--
153	8	10	--	--
203, 204	30	40	50	70
253, 254	30	40	50	70
303, 304	75	100	110	150
353, 354	75	100	150	200
403, 404	150	200	270	370
453, 454	150	200	270	370
504	--	--	430	580
554	--	--	640	870
604	--	--	640	870
705	--	--	1120	1500
805	--	--	1470	2000
905	--	--	1470	2000

Table 1. Flange Bolt Tightening Torques.

5.0 Removal

5.1 Disassemble the coupling in the reverse order as per the applicable assembly procedure.

5.2 KEYED HUBS - Install a puller on the hub using the tapped holes provided in the hub face. Pull the hub off the shaft.

6.0 Disc Pack Replacement

The terminology used to identify parts and the order of assembly may differ from one coupling style to another. Follow the instructions which match the coupling style being installed.

KD2 - For KD20 skip to 6.7

6.1 Remove the center assembly in reverse order as per the applicable assembly procedure. Remove disc pack bolts and nuts.

6.2 Insert the disc pack removal socket into one of the clearance holes in the spacer flange or ring (Figure 6). Install the removal cap screw and turn it until it cannot be tightened any more.

Note: The removal socket is supplied as part of the "parts kit".

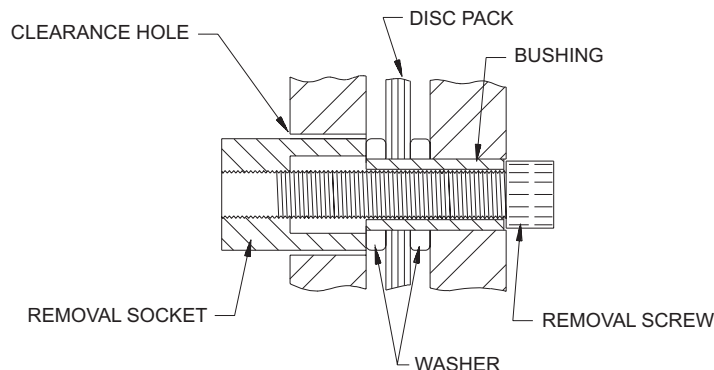

Figure 6. Bolt Disc Pack to Adapter.

6.3 Remove the tool and repeat step 6.2 on all bushings to free the disc pack from the ring and spacer.



Disconnect all power before adjusting units

6.4 Line up the bushings of the new disc pack with the reamed holes in the ring, lightly tap on the bushings to start them into the holes. Insert 3 disc pack bolts and nuts with the bolt heads in the ring counterbore hole, tighten them evenly to pull the bushing into the ring flange (see Figure 7).

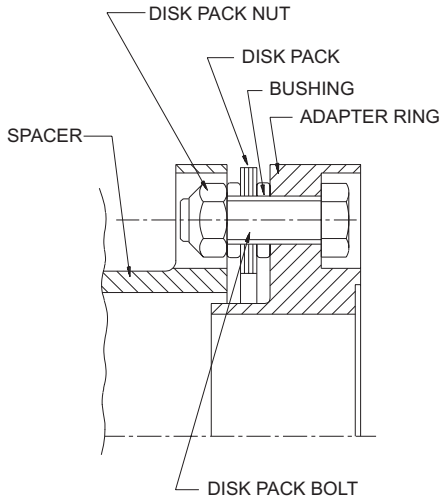

Figure 7. Bolt Disc Pack to Adapter Ring.

6.5 Line up the bushings with the spacer reamed holes, lightly tap the bushings to start them in the holes. Install and tighten 3 disc pack bolts and nuts with bolt heads in the ring (see Figure 8).

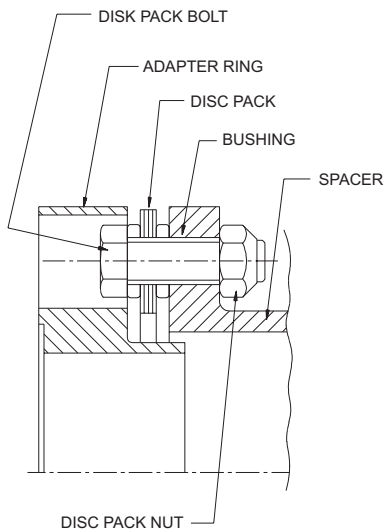

Figure 8. Bolt Disc Pack to Spacer.

6.6 Torque all disc pack fasteners evenly and in successive steps to the value specified in Table 2.

Coupling Size	Tightening Torque (Lightly Oiled)			
	KD2		KD20	
	ft-lb	N-m	ft-lb	N-m
103	8	10	--	--
153	30	40	--	--
203, 204	50	70	55	75
253, 254	75	100	55	75
303, 304	120	160	115	160
353, 354	190	260	175	240
403, 404	290	390	280	380
453, 454	320	430	280	380
504	--	--	420	570
554	--	--	730	1000
604	--	--	1020	1400
705	--	--	1800	2450
805	--	--	2300	3100
905	--	--	2300	3100

Table 2. Disc Pack Bolt Tightening Torques.

KD20

- 6.7 Remove the center assembly in reverse order as per the applicable assembly procedure.
- 6.8 Unbolt the adapter ring from the disc pack. Unbolt the disc pack from the spacer.
- 6.9 Clean and deburr all of the coupling parts.
- 6.10 Line up the new disc pack between the adapter ring and the spacer. Insert the disc pack bolt into the counterbored hole in the adapter ring, and through the disc pack.
- 6.11 Make sure that the spacer is properly indexed for the large clearance holes to receive the bolt ends. Place the spacing washer and disc pack nut on the bolt. Repeat for the other bolts (see Figure 9).

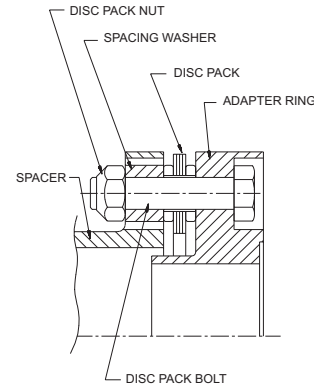

Figure 9. Bolt Disc Pack to Adapter Ring.

6.12 Place a spacing washer over a disc pack bolt. Insert the bolt through the large hole in the adapter ring and through the disc pack bushing and reamed hole in the spacer. Place the disc pack nut on the bolt. Repeat for the other bolts (see Figure 10).

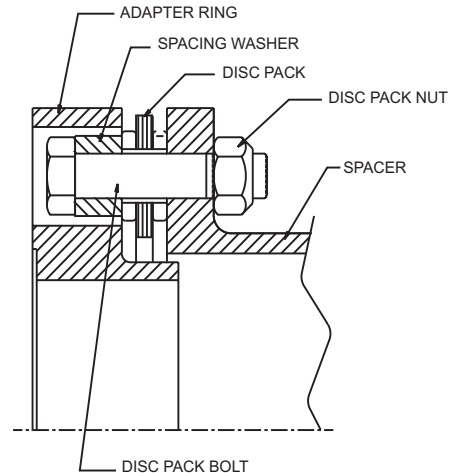

Figure 10. Bolt Disc Pack to Spacer.

6.13 Torque all disc pack fasteners evenly in successive steps to the value specified in Table 2.

7.0 Dynamic Balance

Balanced parts will be marked with the letter "B." The couplings may be component balanced (hubs and center assembly) with no match marks, or assembly balanced as a complete coupling with match marks of the hub to ring connections. If the coupling is supplied with match marks, it must be assembled with the match marks in line.

Note: For balanced couplings, disconnecting the disc packs from the center assemblies disturbs the balance of the coupling. When disc packs are replaced in balanced couplings, the couplings must be balanced before placing back in operation.

8.0 Finish Boring and Keyways

Coupling hubs are often furnished with a "rough stock bore." This rough bore is not necessarily concentric to other hub diameters. To prepare for boring, set-up and indicate the hub as shown in Figure 11.



Disconnect all power before adjusting units

9.0 Bore Sizing and Recommended Fit

The finish bore size should be based on the actual measured shaft dimension, regardless of whether straight or taper shaft. For keyed shafts, a light interference fit based on a nominal interference rate of 0.0005 inch per inch of shaft diameter is suggested, or refer to published AGMA standards. **Do not** exceed an interference fit of 0.001 inch/inch of shaft diameter. If other than a light interference fit is desired, consult the published AGMA boring and keyway standards.

For **Straight Bores**, the rigid hub diameter should be chucked in the boring lathe and dial indicated as shown of Figure 11. For **Taper Bores**, chuck and indicate as shown on Figure 11. Machine the counterbore and **SKIM A REFERENCE DIAMETER** on the hub body. Then chuck the hub as shown on Figure 12, and indicate using the reference diameter before final boring. Run-outs should be as near zero as possible. It is essential that the finished bore be concentric with the two indicating surfaces.

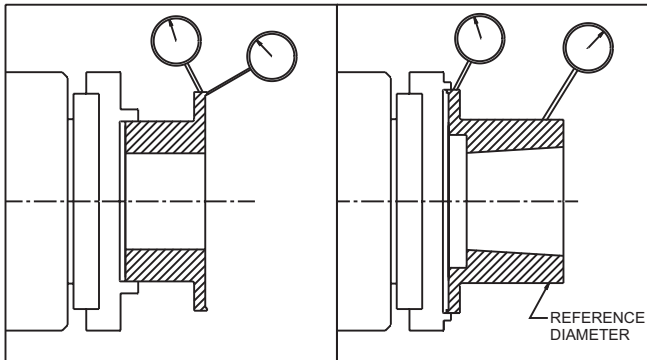

Figure 11

Figure 12

10.0 Keyways

Keyways should be cut to give a tight fit on the sides and slight clearance over the key. Keyways should not have sharp corners. Refer to published AGMA standards for specific dimensioning of coupling bores and keyways.

11.0 General Recommendations

11.1 KOP-FLEX KD2 and KD20 disc couplings are designed to operate for extended periods without the need for lubrication or maintenance. Visual inspection of the disc packs is sufficient to assess the operational condition of the coupling.

11.2 All machinery should be monitored to detect unusual or changing vibration levels. KOP-FLEX KD2 and KD20 couplings, under normal conditions, have no wearing parts and will retain their original balance quality. Any change in vibration levels should be investigated and remedial action should be taken immediately.

5 YEAR WARRANTY REGISTRATION CARD

Name (Last, First) _____

Title: _____

Company Name: _____

Location: _____

Phone: _____

APPLICATION DATA

Coupling Type: _____

HP: _____

RPM: _____

Application: _____

Shaft Size(s): Driving: _____ Driven: _____

Distance Between Shaft Ends _____

Plant Identification Pump # _____ Motor # _____

Send Warranty Card To: Attention Marketing Department

KOP-FLEX, Inc.

Mail to: P. O. Box 1696

or Fax to: 410-787-8424

Baltimore, MD 21203-1696

WARNING

Failure to observe safety precautions could cause personal injury or equipment damage.

Important Safety Instructions

Before start-up . . . for reasons of safety and to extend shaft coupling life, follow these requirements.

1. Coupling guards protect personnel. **ALL COUPLINGS MUST BE COVERED WITH A GUARD AS PER OSHA REQUIREMENTS.**
2. Recheck alignment after all foundation bolts and mechanical connections are tightened.
3. Make sure all fasteners are properly installed and tightened.
4. Take the time to double check your work.
5. Only authorized KOP-FLEX replacement parts are to be used.
6. Call KOP-FLEX for any clarification or questions.

KOP-FLEX

Emerson Power Transmission

P. O. Box 1696

Baltimore, MD 21203-1696

www.emerson-ept.com