



MT3334HD8 MODEM USER GUIDE



MT3334HD8 User Guide

P/N 82063701, Revision B

Copyright © 1997 by Multi-Tech Systems, Inc.

All rights reserved. This publication may not be reproduced, in whole or in part, without prior expressed written permission from Multi-Tech Systems, Inc.

Multi-Tech Systems, Inc. makes no representation or warranties with respect to the contents hereof and specifically disclaims any implied warranties of merchantability or fitness for any particular purpose. Furthermore, Multi-Tech Systems, Inc. reserves the right to revise this publication and to make changes from time to time in the content hereof without obligation of Multi-Tech Systems, Inc., to notify any person or organization of such revisions or changes.

Revision	Date	Description
A	3/31/97	Manual released.
B	5/29/97	Manual updated.

Multi-Tech, CommPlete, RASExpress, MultiExpress, MultiExpress Fax MultiModem, MultiModemZDX, MultiModemManager, and the Multi-Tech logo are trademarks of Multi-Tech Systems, Inc. Other trademarks and trade names mentioned in this publication belong to their respective owners.

Multi-Tech Systems, Inc.
2205 Woodale Drive
Mounds View, Minnesota 55112
(612) 785-3500 or (800) 328-9717
U.S. Fax (612) 785-9874
Technical Support (800) 972-2439 or Email to: tsupport@multitech.com
Internet Address: <http://www.multitech.com>

Federal Communications Commission Statement

This equipment has been tested and found to comply with the limits for a Class A digital device, pursuant to Part 15 of the FCC Rules. These limits are designed to provide reasonable protection against harmful interference when the equipment is operated in a commercial environment. This equipment generates, uses, and can radiate radio frequency energy, and if not installed and used in accordance with the instruction manual, may cause harmful interference to radio communications. Operation of this equipment in a residential area is likely to cause harmful interference, in which case the user will be required to correct the interference at his own expense.

Warning: Changes or modifications to this unit not expressly approved by the party responsible for compliance could void the user's authority to operate the equipment.

FCC Regulations for Telephone Line Interconnection

1. No repairs are to be made by you. Repairs are to be made only by Multi-Tech Systems or its licensees. Unauthorized repairs void registration and warranty. Contact Multi-Tech Systems, Inc. for details of how to have repairs made.
2. When trouble is experienced, you must disconnect your modem from the telephone company's jack to determine the cause of the trouble, and reconnect your modem only when the trouble is corrected.
3. The modem cannot be connected to pay telephones or party lines.
4. If requested by the telephone company, you must notify them of the following before the MT3334HD8 is installed:
 - a. The particular phone line (phone number) to which the connection is to be made.
 - b. The FCC Registration Number:
AU7USA-24457-DE-N
 - c. The manufacturer's name and model number:
Multi-Tech Systems - Model CC9600 CommPlete Communications Server
5. If the telephone company notifies you that your device is causing harm, unplug it. The telephone company may disconnect your service if necessary and also may change its facilities, equipment, operations or procedures which may affect operation of your equipment. Where practical, the telephone company must promptly inform you in writing of the temporary disconnect or change in service, give you the opportunity to make changes allowing uninterrupted service, and inform you of your rights to bring a complaint to the FCC.

FCC Fax Warning

The Telephone Consumer Protection Act of 1991 makes it unlawful for any person to use a computer or other electronic device to send any message via a telephone fax machine unless such message clearly contains in a margin at the top or bottom of each page or the first page of the transmission, the date and time it is sent and an identification of the business or other entity, or other individual sending the message and the telephone number of the sending machine or such business, other entity, or individual.

See your fax software manual for setup details.

Canadian Limitations Notice

Notice: The ringer equivalence number (REN) assigned to each terminal device provides an indication of the maximum number of terminals allowed to be connected to a telephone interface. The termination of an interface may consist of any combination of devices subject only to the requirement that the sum of the ringer equivalence numbers of all the devices does not exceed 5.

Notice: The Industry Canada label identifies certificated equipment. This certification means that the equipment meets certain telecommunications network protective, operational and safety requirements. Industry Canada does not guarantee the equipment will operate to the user's satisfaction.

Before installing this equipment, users should ensure that it is permissible to be connected to the facilities of the local telecommunications company. The equipment must also be installed using an acceptable method of connection. The customer should be aware that compliance with the above conditions may not prevent degradation of service in some situations.

Repairs to certified equipment should be made by an authorized Canadian maintenance facility designated by the supplier. Any repairs or alterations made by the user to this equipment, or equipment malfunctions, may give the telecommunications company cause to request the user to disconnect the equipment.

Users should ensure for their own protection that the electrical ground connections of the power utility, telephone lines and internal metallic water pipe system, if present, are connected together. This precaution may be particularly important in rural areas.

Caution: Users should not attempt to make such connections themselves, but should contact the appropriate electric inspection authority, or electrician, as appropriate.

Table of Contents

1 Introduction

Introduction	2
LED Indicators.....	2
Power Supply.....	2
Manual Organization.....	3
Technical Specifications.....	6

2 Installation

Introduction	8
Safety Warnings.....	8
Pre-Installation Notes	9
Installation Procedure.....	9

3 AT Commands

Working with AT Commands	12
Modes of Operation	12
Command Structure	12
Command Editing.....	13
Dialing Commands.....	16
Dial Modifier Commands.....	16
Phone Number Memory Commands.....	19
Configuration Storage and Recall Commands.....	20
Modem Response (Result Code) Commands.....	21
Online Connection Commands	24
V.34 Commands	28
RS-232 Interface Commands	29
Error Correction and Data Compression Commands.....	31
Speed Conversion Commands	33
Immediate Action Commands.....	35
Flow Control Commands	36
Escape Sequences	39
Remote Configuration Commands.....	40
Line Probe Commands.....	41
Diagnostic Commands	42

4 S-Registers

Introduction	46
S-Registers	46
Reading and Assigning S-Register Values	51
Examples of Assigning Values.....	51
Examples of Reading Values	51
AT Commands that Affect S-Registers	51

5 Testing the MT3334HD8

Introduction	54
Local Analog Loopback Test (V.54 Loop 3)	54
Remote Digital Loopback Test (V.54 Loop 2)	55
Local Digital Loopback Test (V.54 Loop 2)	57

6 Warranty, Service, and Technical Support

Limited Warranty.....	60
Service.....	61
Technical Support	61
Recording Product Information	61
The Multi-Tech BBS	62
Logging onto the Multi-Tech BBS.....	62
Downloading a File	62
Reading a Message.....	63
Leaving a Message	63
Bulletins	63
About CompuServe	63
About the Internet.....	64
About the Multi-Tech Fax-Back Service.....	64
Upgrading the MT3334HD8 Firmware.....	65
Using FlashPro to Upgrade Firmware	65

Appendix A ASCII Conversion Chart.....	68
---	-----------

Appendix B Dial Pulses and Tones.....	69
--	-----------

Appendix C Result Code Summary.....	71
--	-----------

Appendix D S-Register Summary.....	73
---	-----------

Appendix E AT Command Summary.....	75
---	-----------

Appendix F Remote Configuration.....	85
---	-----------

Index.....	87
-------------------	-----------

1 Introduction

Introduction

The Multi-Tech MT3334HD8 is a high speed, high density modem card for the CommPlete Communications Server. Each MT3334HD8 card contains eight integrated 33,600 bps modems. Each modem on the MT3334HD8 card can be configured independently of the others via the CommPlete Communications Server's MR9600 controller, which can support and control up to 12 cards per rack. Users dial into the MT3334HD8's modems through a T1 daughter card on the RASCard that controls the segment. There are no external connectors on the MT3334HD8.

Up to three MT3334HD8 cards can be installed per T1 segment. With eight modems per card, the CommPlete Communications Server can support up to 24 simultaneous data lines per segment, or 96 per CommPlete Communications Server

The MT3334HD8 operates as an enhanced ITU-T V.34 dial-up modem with a maximum speed of 33,600 bits per second (bps). As such, it includes the advanced features of Multi-Tech standalone modems such as the popular MultiModemZDXb.

The MT3334HD8 is registered by the FCC for direct connection to the public telephone networks. No Data Access Arrangements (DAAs) are required.

The MT3334HD8 is fully compatible with the standard AT command set, and is therefore compatible with all popular communications software packages.

This user guide will help you to install, configure, test, and use the MT3334HD8.

LED Indicators

The MT3334HD8 has 16 LED indicators on the front panel, two for each modem:

- CD Carrier Detect.** The CD LED lights when the modem detects a valid carrier signal.
- OH Off Hook/Out of Service.** The OH LED lights when the modem is off hook, which occurs when the modem is dialing, online, or answering a call. The LED flashes when the modem is in the busy-out or out-of-service state.

Power Supplies

DC voltages are supplied to all modems in the CC9600 rack through two PS9600 universal input switching power supplies designed for conventional 115 or 230 VAC input. The power supplies are designed for redundant, fail-safe operation. If one should fail, the other can supply the power requirements of the entire CommPlete Communications Server. Each PS9600 power supply has one LED indicator that indicates the presence of all supply voltages.

Manual Organization

Chapter 1 Introduction

This chapter describes the MT3334HD8 and its LED indicators, gives its technical specifications, and provides a guide to the organization of the manual.

Chapter 2 Installation

This chapter describes how to install the MT3334HD8 into the CC9600 chassis.

Chapter 3 Command Mode Operation

This chapter provides an introduction to MT3334HD8 command mode fundamentals, followed by a detailed explanation of each AT command, providing examples where applicable.

Chapter 4 S-Registers

This chapter describes the MT3334HD8's S-registers, which are used to store various modem options. Each S-register is defined and explained.

Chapter 5 Testing the MT3334HD8

This chapter describes loopback testing for the MT3334HD8.

Chapter 6 Warranty, Service, and Technical Support

This chapter provides the terms of the MT3334HD8's warranty, instructions for obtaining factory service, and information about Multi-Tech's BBS and technical support. Information on upgrading the MT3334HD8's firmware is also provided.

Appendix A ASCII Conversion Chart

Appendix B Dial Pulses and Tones

Appendix C Result Code Summary

Appendix D S-Register Summary

Appendix E AT Command Summary

Appendix F Remote Configuration

Technical Specifications

Model Number	MT3334HD8	
Data Rates (Modem)	Eight independent modems (Modem A, B, C, D, E, F, G, H), each operating at 33,600, 31,200, 28,800, 26,400, 24,000, 21,600, 19,200, 16,800, 14,400, 12,000, 9600, 4800, 2400, 1200, or 0-300 bps	
Data Rates (Fax)	14,400, 9600, 4800, and 2400 bps	
Data Format (Modem)	Serial, binary, asynchronous at all data rates	
Configuration	Each of the card's modems is independently configurable	
Compatibility (Modem)	ITU-T V.42bis, V.42, V.34plus, V.34, ITU-T V.32bis, V.32, V.25bis, V.21, V.22bis, V.22, V.23, V.17, Bell 212A* and 103/113*	
Compatibility (Fax)	ITU-T Group 3, T.4, T.30, V.21, V.27ter, V.29, V.17, and EIA TR29.2	
Error Correction	ITU-T V.42 (MNP® Classes 3 and 4, and LAP-M)	
Data Compression	ITU-T V.42bis (4:1 throughput) or MNP 5 (2:1 throughput)	
Speed Conversion	Serial port data rates adjustable to 300, 1200, 2400, 4800, 9600, 19,200, 38,400, 57,600, and 115,200 bps	
Flow Control	XON/XOFF, CTS/RTS, ENQ/ACK	
Mode of Operation	Half or full duplex over dial-up lines; automatic or manual dialing, automatic or manual answer	
Intelligent Features	Fully AT command compatible; auto dial; redial; repeat dial*; dial linking*; pulse or tone dial; dial pauses; call status display; auto-parity and data rate selection; keyboard-controlled modem options; nonvolatile memory; on-screen displays of modem parameters, stored telephone numbers, and help menus; and remote configuration.	
AT Commands	100% compatible with standard AT command set	
Command Buffer	60 characters	
Automatic Dialing	Standard AT command asynchronous dialing	
Modem Modulations	FSK at 300 bps, PSK at 1200 bps, QAM at 2400, 4800, and 9600 bps (non-trellis), QAM with trellis-coded modulation (TCM) at 9600, 12,000, 14,400, 16,800, 19,200, 21,600, 24,000, 26,400, 28,800, 31,200, and 33,600 bps	
Fax Modulations	V.21 CH2 FSK at 300 bps V.27ter DPSK at 4800 and 2400 bps V.29 QAM at 9600 and 7200 bps V.17TCM at 14400, 12000, 9600, and 7200 bps	
Carrier Frequencies ITU-T V.34	1600, 1646, 1680, 1800, 1829, 1867, 1920, 1959, 2000 Hz	
Carrier Frequencies: V.22bis/V.22 or Bell 212A Standard	Transmit originate:	1200 Hz
	Transmit answer:	2400 Hz
	Receive originate:	2400 Hz

(2400 & 1200 bps)	Receive answer:	1200 Hz
Carrier Frequencies: Bell 103/113 (300 bps)	Transmit originate:	1270 Hz mark 1070 Hz space
	Receive originate:	2225 Hz mark 2025 Hz space
	Transmit answer:	2225 Hz mark 2025 Hz space
	Receive answer:	1270 Hz mark 1070 Hz space
Carrier Frequencies: V.21	Transmit originate:	980 Hz mark 1180 Hz space
	Receive originate:	1650 Hz mark 1850 Hz space
	Transmit answer:	1650 Hz mark 1850 Hz space
	Receive answer:	980 Hz mark 1180 Hz space
Carrier Frequencies: V.23	Transmit originate:	390 Hz mark 450 Hz space
	Receive originate:	1300 Hz mark 2100 Hz space
	Transmit answer:	1300 Hz mark 2100 Hz space
	Receive answer:	390 Hz mark 450 Hz space
Fax Modulations	V.21Ch2 FSK at 300 bps V.27ter DPSK at 4800 and 2400 bps V.29 QAM at 9600 and 7200 bps V.17 TCM at 14400, 12000, 9600, and 7200 bps	
Fax Carrier Frequencies	V.21 CH2 (half duplex) 1650 Hz mark, 1850 Hz space for transmit originate 1650 Hz mark, 1850 Hz space for transmit answer V.27ter: 1800 Hz Originate/Answer V.29 QAM: 1700 Hz Originate/Answer V.17 TCM: 1800 Hz Originate/Answer	
Transmit Level	-13 dBm	
Frequency Stability	+0.01%	
Receiver Sensitivity	-43 dBm under worst case conditions	
AGC Dynamic Range	43 dB	
Serial Interface	EIA RS-232C	
Diagnostics	Power-on self-test; ITU-T V.54 local analog loop, local digital loop, remote digital loop.	
Firmware Upgrades	Flash memory; available on Multi-Tech's BBS	
Indicators	LEDs for Carrier Detect and Off Hook/Out-Of-Service	
Environmental	Temperature range: 0°–50° C (32°–120° F) Humidity range: 20–90% (noncondensing)	

Power Requirements	5 VDC at 0.95 A ±16 VDC at 0.1 A
Power Consumption	Approximately 6 watts
Dimensions	23.3 × 2.3 × 29.2 cm (9.2 × 0.9 × 11.5 in.) H × W × D
Weight	1.1Kg (2.5 lb.)
Limited Warranty	Two years
Fuses	F1 (+5 V), F2 (-16 V), F3 (+16 V)

2 Installation

Introduction

This chapter describes how to install the MT3334HD8 modem card into a CommPlete Communication Server CC9600 chassis. This equipment should be installed only by a qualified service person.

The MT3334HD8 assembly consists of a high-density modem card and a front panel. Figure 1 shows the layout of the MT3334HD8 card. The MT3334HD8 assembly plugs into power and data, Ethernet, and T1 bus connectors on the inside of the CC9600 chassis. There are no external connectors.

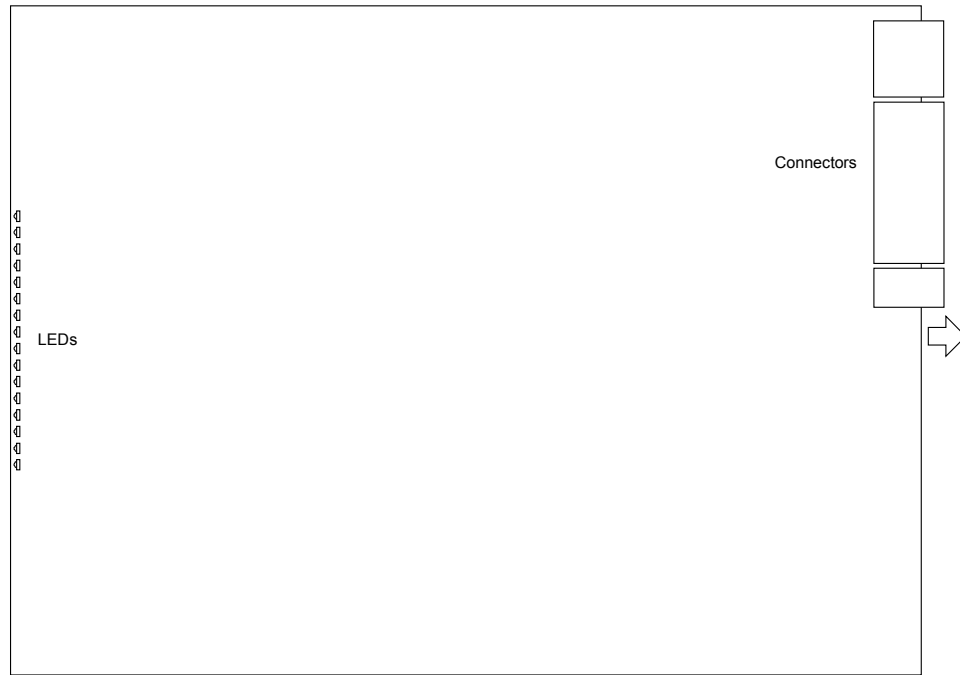

Figure 1. MT3334HD8 modem card.

Safety Warnings

- ✓ Never install telephone wiring during a lightning storm.
- ✓ Never install telephone jacks in wet locations unless the jacks are specifically designed for wet locations.
- ✓ Never touch uninsulated telephone wires or terminals unless the telephone line has been disconnected at the network interface.
- ✓ Use caution when installing or modifying telephone lines.
- ✓ Avoid using a telephone (other than a cordless type) during an electrical storm. There may be a remote risk of electrical shock from lightning.
- ✓ Do not use the telephone to report a gas leak in the vicinity of the leak
- ✓ Ports that are connected to other apparatus are defined as SELV. To ensure conformity to EN 41003, ensure that these ports are only connected to the same type on the other apparatus.

Pre-Installation Notes

Warning: Interconnection directly, or by way of other apparatus, of ports marked “SAFETY WARNING see instructions for use” with ports marked or not so marked may produce hazardous conditions on the network. Advice should be obtained from a competent engineer before such a connection is made.

- All installation must be done by a qualified service person.
- To reduce emissions, be sure to use blanking plates to cover empty slots in the CC9600 chassis.
- Any other apparatus, including cable and wiring, connected between the MT3334HD8K modem and the point of connection to any speech band circuit shall comply with the following:
 1. The overall characteristics of this apparatus shall be such as to introduce no material effect upon the electrical conditions presented to one another by the modem and the speech band circuit.
 2. The apparatus shall comprise only
 - a. apparatus approved for the purpose of connection between the modem and a speech band circuit; and
 - b. cable and wiring complying with a code of practice for the installation of equipment covered by this part of BS 6328 or such other requirements as may be applicable.

Note: Such apparatus may have been approved subject to limitations in its use.

Installation Procedure

1. Unpack the MT3334HD8 assembly from its packaging and save the packaging for possible future use. Perform a visual inspection of the MT3334HD8. If you are concerned about its condition, call Technical Support for instructions.
2. Turn off *both* PS9600 power supplies.
3. The MT3334HD8 must be installed in a segment in which a RASCard with a T1 module is installed. Remove a blank device panel or previous MT3334HD8 card from that segment.
4. Supporting the MT3334HD8 by the front panel and the bottom edge of the card, place it into the CC9600's open device slot. Make sure the edges of the MT3334HD8 card mate properly with the guides of the device slot.
5. Slide the MT3334HD8 into the CC9600 chassis until you feel the MT3334HD8's connectors mate with the CC9600's bus connectors.
6. Tighten the MT3334HD8's retaining screws.
7. Turn on the PS9600 power supplies.
8. Note the PS9600 LED indicators. If they are not lit, see Chapter 5. If they are lit, proceed with MultiModemManager operation (Chapter 4 of the MultiModemManager *Owner's Manual*).

Note: A self-test runs each time the CommPlete Communications Server is turned on. Refer to Chapter 5 of the MultiModemManager Owner's manual for more details on the power-on self-test.

3 AT Commands

Working with AT Commands

The MT3334HD8's modems are controlled by instructions called *AT commands*, so called because the attention characters *AT* precede each command or command string (sequence of commands). You can send commands to the modem from your keyboard while in terminal mode, or you can use communications software to issue these commands automatically.

A MT3334HD8 modem is in command mode when it is not dialing or online. When it is in command mode, you have access to a complete communications system that allows you to use several features, including the basic AT command set described in this chapter. Using the basic AT command set, you can enter phone numbers for automatic dialing, configure modem options, and monitor telephone activity. In addition, you can command your modem to perform advanced features such as error correction, data compression, speed conversion, and more.

This chapter describes the MT3334HD8's operational modes, and shows you how to use each of the MT3334HD8's AT commands. MT3334HD8 commands and responses are compatible with all systems and with all data communications software using the AT command set.

For easy reference, the MT3334HD8 has a help command that provides you with short, on-screen descriptions of the modem commands. The help command is explained later in this chapter.

Modes of Operation

The MT3334HD8 operates in two basic functional modes: *command mode* and *online mode*. (There is also an in-between state, *wait-for-carrier*, in which the modem is out of command mode but not yet online.)

When you power up the modem, it is in command mode, and is ready to accept and respond to commands from your keyboard or software.

An MT3334HD8 modem enters online mode after it dials, connects with another modem, and detects a valid carrier signal. If it does not detect a carrier signal within the time frame controlled by register **S7**, the modem abandons the call and re-enters command mode.

You can make the modem enter online mode without dialing by typing either the **D** command or the **A** command.

The modem exits online mode if the carrier signal is lost or intentionally dropped. When this happens, the modem hangs up and re-enters command mode.

By sending certain "escape" characters to the modem while online, you can make it enter command mode without losing the carrier signal.

For auto answer-only applications, you can disable a modem's ability to recognize AT commands by using the **%DC1** command. When you do this, the MT3334HD8 ignores all commands, and functions as a non-intelligent modem. The **%DC1** command and other MT3334HD8 commands are explained later in this chapter.

Command Structure

You can control a wide variety of modem operations and options when the modem is in command mode. AT commands tell the modem to dial a number, to answer a call, to operate at a certain speed, to use a certain compression technique, and many other functions. AT commands consist of one or two letters, which may be preceded by an ampersand (&), a dollar character (\$), a pound character (#), a percent character (%), or a greater-than character (>). The **Q** command, for example, determines whether the modem returns result codes, while the **&Q** command selects which AT command set the modem uses.

A parameter after a command (0, 1, 2, etc.) tells the modem which option to use. If you do not specify a parameter, the modem assumes the 0 (zero) option. **E**, for example, is the same as **E0**. You can issue several commands on a single line (a command string) as long as the line does not exceed 60 characters. Note that though **Q1** is one command, it counts as two characters in the command line.

Each command has a valid range of parameters; for instance, **&W** can have only 0 or 1 as a parameter. Valid commands generate an OK result code. A few generate an additional response, such as a list of parameters. An invalid command, such as **&W3**, which has a parameter outside the valid range, generates an ERROR result code. Most commands have a default parameter, one that is enabled when the modem is turned on or reset with the **ATZ** or **AT&F** command. Factory defaults are stored in read-only memory (ROM), and cannot be changed. User-defined defaults can be stored in nonvolatile random-access memory (NVRAM), and can be changed or deleted at will.

Command Editing

Always begin a command with the letters *AT*. You may type the command in upper case or lower case, but not both. The AT command is not executed until you press the ENTER key. Use the BACKSPACE key to erase the previous command character; it will not erase the AT characters once they are typed. If your keyboard has no BACKSPACE key, use CTRL+H. You can change the character recognized by the modem as BACKSPACE to any other ASCII character by changing register **S5**.

To cancel an entire command that has been typed but not yet executed, press CTRL+X. This also clears the command buffer. The effect is the same as backspacing the command, only quicker.

The MT3334HD8 stores characters entered in a command in the modem's command buffer until they are executed by pressing ENTER. The command buffer's capacity is 60 characters. The attention characters (AT) do not count in the 60 allowed command characters. You may use spaces for increased readability when typing a command; they are neither stored in the command buffer nor counted in the 60 allowed characters. Hyphens, parentheses, etc., are not allowed.

If you exceed the 60-character limit or type invalid characters, the command buffer is automatically erased and an ERROR message is displayed. You must then retype the command within the 60-character limit, using only the allowed characters.

The commands in this chapter are organized by function. A brief summary follows.

Table 1. AT Commands by Function

Topic	Command	Description	Page
Dialing Action	D	Dial	16
	A:	Continuous redial	
	H	On-hook/off-hook	
Dial Modifiers	P	Pulse dialing	16
	T	Tone dialing	
	W	Wait for new dial tone	
	R	Reverse originate/answer mode	
	,	Dialing pause	
	:	Continuous redial	
	;	Return to command mode after dialing	
	!	Flash on-hook	
	@	Quiet answer	
	\$	Call card tone detect	
Phone Number Memory	D...N	Store a phone number	19
	N	Dial a stored number	
	N...N	Number linking	
	L	List stored telephone numbers	
Configuration Storage & Recall	&W	Store configuration	20
	&F	Load default configuration	
	Z	Reset modem	
Modem Responses (Result Codes)	E	Echo command mode characters	21
	Q	Result codes: enable/disable	
	&Q	Result codes: Multi-Tech or standard	
	V	Result codes: verbose/terse	
	X	Result codes and call progress	
Online Connection	&A	Answerback	24
	#A	Auto speed detection	
	B	Answer tone	
	%DC	Command mode control	
	&CD	Clear-down at disconnect	
	>DT	DTMF detection	
	#F	Fallback modes when online	
	&G	Guard tones	
	*H	Busy-Out After Disconnect	
	&P	Pulse dial ratios	
	&RD	Square wave ring detect	
	\$T	Calling tones	
	#T	Trellis-coded modulation	
	Y	Long space disconnect	
	V.34 Controls	%F	
&RA		Asymmetric bit rate	
RS-232 Interface Controls	&C	Carrier Detect control	29
	&D	Data Terminal Ready control	
	&R	Clear to Send control	
	&S	Data Set Ready control	
	&RF	CTS/RTS interaction control	
	&SF	DSR/CD interaction control	

Error Correction & Data Compression	&E0	Non-error correction mode	31
	&E1	Auto-reliable mode	
	&E2	Reliable mode	
	&E14	Data compression disabled	
	&E15	Data compression enabled	
	#L	V.42 error correction modes	
	\$E	V.42 error correction at 300 bps	
	\$A	Auto-reliable buffering	
	\$F	Auto-reliable fallback character enable	
	\$R	Retransmit count	
Speed Controls	\$BA	Baud adjust	33
	\$MB	Modem baud rate	
	\$SB	Serial port baud rate	
Immediate Action	A/	Repeat last command	35
	I	Inquire product code	
	L5	List current operating parameters	
	L6	List S-register values	
	L7	List current operating parameters	
	L8	List online diagnostics	
	&RN	Rate renegotiation	
	&RR	Retrain	
Flow Control	&BS	Maximum reliable block size	36
	\$EB	Asynchronous word length (10/11-bit)	
	&E3	Flow control disabled	
	&E4	Hardware flow control	
	&E5	XON/XOFF flow control	
	&E6	XON/XOFF no pass-through	
	&E7	XON/XOFF pass-through	
	&E8	Hewlett Packard ENQ/ACK pacing off	
	&E9	Hewlett Packard ENQ/ACK pacing on	
	&E10	Non-error correction mode flow control off	
	&E11	Non-error correction mode flow control on	
	&E12	Pacing off	
	&E13	Pacing on	
	#X	Number of XOFF characters sent	
Escape Sequences	+++AT<CR>	Default in-band escape sequence	39
	<BREAK>AT<CR>	Alternate out-of-band escape sequence	
	%E	Escape sequence selection	
	A	Force answer mode	
	O	Go back online	
Remote Configuration	%%%AT<CR>	Remote configuration escape sequence	40
	#I	Change login password	
	#S	Change setup password	
Line Probes	%DP	Read line probe data	41
	%DF	Format line probe data	
	&RP	Immediate line probe	
	L9	Display signal strength	
	L10	Display signal to noise ratio	
	L11	Display noise strength	
Diagnostics	&T	Respond to remote digital loopback signal	42
	U	Loopback test modes	

Dialing Commands

Dialing commands are used to dial and to hang up.

Ds **Dial**

s = phone number

Default: none

The letter *D* in a command causes the modem to dial the telephone number immediately following it. For example, if you type **ATD5551212<CR>**, the modem dials the number 555-1212.

The MT3334HD8 supports several dialing methods. With the **D** command, you can specify either pulse (**ATDP**) or tone (**ATDT**) dialing. You can also modify the dialing command with several characters that are explained in “Dial Modifier Commands” in this chapter.

The MT3334HD8 lets you select either smart (wait-for-dial-tone) dialing or blind dialing. With smart dialing, the modem waits for and detects dial tones and busy signals. With blind dialing, the modem works with timed pauses (determined by the value of register **S6**), not dial tone and busy signal detection. See the **X** command for more information on blind and smart dialing.

A: **Continuous Redial**

If you select smart dialing through the **X3** or **X4** command, the **A:** command lets you continuously redial a busy number until your call is answered. (North American units have a maximum of 10 redials; this command is not available on UK or International models.)

Use this command only if you have reached a busy number after executing a normal dial command. Type **A:** (you need not type *AT*, nor do you need to press **ENTER**), and the modem redials the number. If you again reach a busy signal, the modem continues to redial until it gets through. You can stop the modem from redialing by pressing any key.

To save a step when redialing a phone number, enter a colon (**:**) at the end of the phone number. The result is the same as if you had entered **A:**

Hn **On-Hook/Off-Hook**

n = 0 or 1

Default: none

You can make the modem go on-hook (hang up) or go off-hook with the **H** command.

H0 (or **H**) hangs up the modem

H1 brings the line off-hook, just as if you had picked up the telephone handset.

It is not necessary to use the **H1** command to bring the line off-hook when using the **D** command. The modem automatically goes off-hook when you press **ENTER** at the end of the dial command.

Dial Modifier Commands

The dial string can include the digits 0 through 9, the pound sign (**#**), the asterisk (*****), and the letters *A*, *B*, *C*, or *D*. The latter are used by some PBXs; the exact function will depend on the PBX manufacturer’s feature set and implementation. There are also several command characters, called “dial modifiers,” that can be included within a dialing command after the letter *D*. Their functions include pulse or tone dialing,

pauses in the dial sequence, automatic redials if a number is busy, and reverting to command mode or switching to answer mode after dialing.

P, T Pulse or Tone Dialing

Default: **P**

The MT3334HD8's modems can dial numbers by using pulse dialing, tone dialing, or a combination of both methods. Pulse dialing, used by rotary-dial telephones, uses the timed opening and closing of a relay to encode the numbers. Tone dialing, used by push-button (touch-tone) telephones, uses dual tone multifrequency (DTMF) dialing.

P selects pulse dialing.

T selects tone dialing.

Insert **P** or **T** in the dialing command just before the digits you want to pulse- or tone-dial.

For example, to pulse-dial the number 555-1212, type **ATDP5551212** and press ENTER. To tone-dial the same number, type **ATDT5551212** and press ENTER. If neither pulse nor tone dialing is specified in the dial command, the modem uses whatever method was used last.

Immediately after the modem has been turned on or reset, it uses pulse dialing, even if you do not include **P** in your dial command.

As an example of combining pulse and tone dialing, assume you are calling out of a PBX (switchboard) system where a 9 has to be pulse-dialed, then the rest of the number has to be tone-dialed after pausing for a second dial tone. To dial this example, type **ATDP9,T5551212** and press ENTER. (The comma causes a pause.)

W Wait for New Dial Tone

Inserting **W** into the dialing command causes the modem to wait for another dial tone before it resumes dialing. (It is not necessary to enter **W** at the beginning of the dialing command.)

Because the modem must be able to detect the dial tone for this command to work, you also must select wait-for-dial-tone dialing with the **X2** or **X4** command.

Rn Reverse Originate/Answer Mode

$n = 0$ or 1

Default: **R0**

The **R** command lets you reverse the modem's mode of operation from originate to answer, or from answer to originate; for example, if you need the modem to answer the phone but then go into originate mode.

R (with no number) at the end of the dialing string reverses in originate mode.

R0 disables mode reversing.

R1 enables mode reversing when **R** is added to the dial string.

, Dialing Pause

Enter a comma in the dialing string to make the modem pause while dialing. This pause lasts two seconds (North American models) or four seconds (U.K. and International models) for each comma entered. You can force longer pauses by entering multiple commas, or you can change the length of the pause caused by a comma by setting register **S8** to any value from 0 through 255 seconds (North American models), 4 through 7 seconds (U.K. models) or 4 through 255 seconds (International models).

Each comma in a dialing command counts as one of the 60 allowed characters.

: Continuous Redial

Enter a colon (:) as the last character of a dialing command to cause the modem to continuously redial the number, if it detects a busy signal, until the call is answered. North American models are limited to 10 redials. You must select smart dialing (**X3** or **X4**) for this to work. (Not available in U.K. or International models.)

Note: This command has largely been superseded by software-based continuous redial features.

; Return to Command Mode After Dialing

Enter a semicolon (;) as the last character of a dialing command to cause the modem to return to command mode immediately after executing the command instead of waiting for a carrier signal and going online.

For example, type **ATDT5551212;** to tone-dial the number and immediately go back into command mode. The semicolon is useful when modem data transfer is not desired, as in voice communications, or in applications using touch tones as a data entry method, such as bank-by-phone.

! Flash On-Hook

Some switchboard systems react to a momentary on-hook condition. Insert an exclamation mark into the dialing command to cause the modem to "flash" on-hook for half a second, just as if you had pressed the switch hook on a telephone set for half a second. (With U.K. models, the exclamation mark causes the modem to flash on-hook for 90 milliseconds.)

For example, to flash on-hook to transfer to extension 5678 after dialing the number 555-1234, type **ATDT5551234,,!5678**. The commas cause a 4-second pause.

@ Quiet Answer

Use the @ command to access a system that does not provide a dial tone. The @ command causes the modem to wait before processing the next character in the dialing string. The wait is for one or more rings back followed by five seconds of silence.

For example, `ATDT5551212@6313550` causes the modem to dial the first number (555-1212), then wait for the time specified in register `S7` for at least one ringback and five seconds of silence. If the modem detects a busy signal, it hangs up and generates a `BUSY` result code. If it does not detect five seconds of silence, it hangs up and generates a `NO ANSWER` result code. If it does detect five seconds of silence, it dials the second number (631-3550).

\$ Call Card Tone Detect

Use the \$ command to dial services that require you to enter your call card number after a tone. A \$ character in the dialing string causes the modem to pause and wait for an AT&T call card “bong” or a 1600 Hz tone (prevalent in the U.K.). When the modem detects the tone, it processes the rest of the dialing string. If it does not detect a tone within the time set by register `S7` (a 45-second default), the modem aborts with a `NO CARRIER` message. Pressing any key also aborts the \$ command.

In the following example, the \$ command is placed between an access/phone number and the caller’s credit card number:

```
ATDT1028806127853500$123456789
```

Phone Number Memory Commands

The modem can store up to two telephone numbers in nonvolatile memory. You can store the numbers with the `DsNd` command, dial them with the `Nd` command, link them so that one will be automatically dialed after the other with the `NdNe` command, or list them with the `L` command.

DsNd Store a Phone Number

`s` = phone number `d` = 0 or 1

Default: none

You can store a telephone number command string of up to 60 characters in the modem’s phone number memory. You can store two of these 60-character strings using the `DsNd` command. The memory locations are labeled `N0` and `N1`.

Store a command line by typing it as you would any other command, appending the appropriate `Nd` memory location.

For example, the tone-dialed number 1-612-555-1212 is stored at memory location `N0` by typing `ATDT16125551212N0` and pressing `ENTER`. The number is not dialed with this store command.

After storing a number, check to see that it has been stored correctly by typing `ATL` and pressing `Enter`.

When you store a phone number, you store the entire command string, so you can effectively create a macro for each number. For example, if you know a particular number needs to have extended result codes, detect busy or dial tone, error correction, `XON/XOFF` flow control, pacing, and data compression enabled, the command to store the entire command string at location `N0` is `ATX4&E1&E5&E13&E15DT16125551212N0`.

Nd Dial a Stored Number

`d` = 0 or 1

Default: none

You can automatically dial a telephone number that is stored in the modem's number memory by typing **ATN*n***, where *n* = 0 or 1. For example, you can dial a number stored at N0 by typing **ATN0** in terminal mode and pressing ENTER.

Warning: Do not include the letter *D* in this command, or the stored number will be erased.

NdNe Number Linking

d = 0 or 1 *e* = 1 or 0

Default: none

Number linking allows the modem to dial a second stored number if the first stored number is busy. (See the **DsNd** command.) This command is useful when a computer can be accessed through more than one phone number. However, it cannot be used with blind dialing, since busy signals would not be detected.

To link the number in memory location N0 to the number in N1, type **ATNON1** and press Enter. You can cycle back and forth between two numbers by linking them several times in one command: **ATNON1NON1NON1<CR>**. The only limit on the number of times the modem can cycle between two numbers is the 60-character maximum allowed in a command line.

L List Stored Telephone Numbers

Use the **L** command to display dialing commands stored in the modem's nonvolatile memory. Typing **ATL<CR>** displays the stored N numbers in the following format:

```
0 T14082345678
1 P9,T14089876543
```

All digits and command letters are displayed. The N number is shown first, followed by the complete dialing command and telephone number as originally entered.

Configuration Storage and Recall Commands

The MT3334HD8 stores parameters in two places. It stores factory default parameters in read-only memory (ROM), and customized parameters in nonvolatile random access memory (NVRAM). You cannot change the default parameters in ROM; however, you can change parameters in temporary memory and then store them in NVRAM as custom settings. You can then recall the custom settings as if they were factory default settings.

&Wn Store Configuration

n = 0 or 1

Default: **&W1**

The **&W** command stores current AT commands and S-register values in nonvolatile memory, so you won't lose your custom settings when you turn off the modem or reset it.

&W0 (or **&W**) stores all current AT command and S-register values in nonvolatile random access memory (NVRAM) and configures the modem so that it reads your custom settings in NVRAM when the modem is turned on or when it is reset with the **Z** command. (The **&F** reset command will continue to read the factory default settings in ROM unless you store the **&F9** command.)

&W1 erases your custom settings in NVRAM when the modem is turned off or reset, causing the modem to read the factory default settings in ROM when it is subsequently turned on or reset.

For further information on how the **&W** command interacts with the reset commands, see Table 2.

&Fn Load Default Configuration $n = 0, 8, \text{ or } 9$ Default: **&F8**

MT3334HD8 modems store factory default AT command settings and S-register values in read-only memory (ROM); they store your custom AT command and S-register values in nonvolatile random access memory (NVRAM).

The **&F0** (or **&F**) command resets the modem to the factory default values stored in ROM or to your custom values stored in NVRAM, depending on whether you last stored an **&F8** or an **&F9** command.

When **&F8** is stored and an **&F** command is issued, the modem reads the factory default settings stored in ROM.

When **&F9** is stored and an **&F** command is issued, the **&W** setting determines whether the modem reads settings stored in NVRAM or ROM. If the modem is set to **&W0**, it reads your custom settings stored in NVRAM. If the modem is set to **&W1**, it erases your stored settings (including the **&F9** command) and reads the factory default settings stored in ROM. Many communications programs issue the **&F** command automatically—the **&F9** command allows you to select your own defaults.

Note that for either an **&F8** or an **&F9** command to be effective after a reset it must be stored using the **&W0** command.

Table 2 summarizes how the **&F** and **Z** reset commands interact with the **&W** command; note that the **&F** reset command operates differently from the **Z** reset command:

Table 2. Where the Modem Reads Configuration Parameters

Previous Command	AT&F	Power-On and ATZ
AT&W1 (default)	ROM	ROM
AT&W0	ROM	NVRAM
AT&F8&W0	ROM	NVRAM
AT&F9&W0	NVRAM	NVRAM

Z Reset Modem

The **Z** command resets the modem to its default configuration and clears the command buffer. The result is the same as turning the modem off and on. When you type **ATZ**, the state of the **&W** command determines where the default values originate. **&W0** defaults come from the customized configuration in NVRAM, and **&W1** defaults come from the factory default configuration in ROM. Because **Z** clears the command buffer, it must be the last command in a command string; normally it is issued by itself: **ATZ**.

Note that the **Z** reset command operates differently from the **&F** reset command. See Table 2 on page 21.

Modem Response (Result Code) Commands

The MT3334HD8's modems can give responses to commands. The most common one is *OK*, but the modems also can alert you or your software to dial tones, busy signals, connection speeds, and whether the connection is made with error correction or compression enabled. These responses are called *result codes*, and they can be terse or verbose, Multi-Tech or standard, basic or extended.

En Echo Command Mode Characters

$n = 0$ or 1

Default: **E1**

Normally, when you type commands on the keyboard, the modem echoes the characters back to the computer or terminal, which displays them on the monitor. Use the **E** command to turn this feature off and on.

E0 disables the echo.

E1 enables the echo.

Qn Result Codes Enable/Disable

$n = 0, 1,$ or 2

Default: **Q0**

You can use the **Q** command to enable or disable result codes for applications such as computer-controlled auto dialing. You can also use it to disable responses and echo in answer mode while leaving originate mode still intelligent; this is called the no response answer mode of operation.

Q0 (or **Q**) enables result codes.

Q1 disables result codes for applications such as computer-controlled auto-dialing.

Q2 enables the no response answer mode, which leaves originate mode intelligent while turning off answer mode responses and echo.

&Qn Result Codes (Multi-Tech or Standard AT)*n* = 0 or 1Default: **&Q0**

The MT3334HD8 gives you a choice between Multi-Tech result codes and standard AT command set responses. Multi-Tech result codes give you more information, but some datacomm programs may not be able to use them, in which case, select the standard result codes.

&Q0 selects Multi-Tech responses with RELIABLE, LAPM, and COMPRESSED modifiers. With **&Q0**, the verbose result code for 14,400 bps is `CONNECT 14400 LAPM COMPRESSED`.

&Q1 selects AT responses with no RELIABLE, LAPM, or COMPRESSED modifiers. With **&Q1**, the verbose result code for 14,400 bps is `CONNECT 14400`.

Vn Result Codes (Verbose/Terse)*n* = 0 or 1Default: **V1**

The **V** command controls whether the modem's result codes display as verbal ("verbose") or digital ("terse") messages. For example, if no carrier signal is detected after dialing, the result can be displayed either as `NO CARRIER`, or as the digit 3.

V0 (or **V**) displays the modem's result codes as digits.

V1 displays result codes as words.

Xn Result Codes and Call Progress Selection*n* = 0–4Default: **X0**

The **X** command selects which result codes the modem provides in command mode and whether the modem uses "smart dialing" or "blind dialing". When it smart dials, the modem listens for dial tones and busy signals and responds to them. When it blind dials, the modem ignores the signals and relies on timing instead.

X0 causes the modem to blind dial. Instead of looking for a dial tone, it pauses for the time set in register **S6** and then dials regardless. Once a connection has been made, it sends the Bell 103 basic code `CONNECT` to the terminal. It ignores any busy signals.

X1 causes the modem to blind dial, but in addition to the basic `CONNECT` code it provides extended codes consisting of the word `CONNECT` and the speed of the connection: `CONNECT 2400`, `CONNECT 4800`, `CONNECT 9600`, `CONNECT 14400`, `CONNECT 19200`, `CONNECT 28800`, and so forth. In this mode, the modem does not recognize or respond to dial tones or busy signals.

X2 causes the modem to wait for a dial tone before dialing. If it does not detect a dial tone within the time set by **S6**, the modem sends a `NO DIALTONE` result code to the terminal. In this mode, the modem provides extended result codes, but does not respond to busy signals.

X3 causes the modem to blind dial, but also it looks for a busy signal, and if it detects one, it sends a `BUSY` result code to the terminal. In this mode, the modem provides extended result codes, but it does not respond to dial tones.

X4 causes the modem to look for a dial tone and a busy signal, and respond with `NO DIALTONE` or `BUSY`, as appropriate. It also provides extended result codes. It is the most useful setting for most datacomm programs.

&An Answerback

$n = 0$ or 1
Default: **&A0**

The **&A** command controls the MT3334HD8's answerback feature. Answerbacks are used in some online realty applications and elsewhere as a security measure. The **&A** command enables a modem to return a message to an identification request from another computer. The default identification is MESSAGE NOT PROGRAMMED.

&A0 disables the answerback feature.

&A1 enables the modem to return a message to an inquiry.

Online Connection Commands

The following commands control the conditions of the online connection.

#An Auto Speed Detection

$n = 0-3$
Default: **#A0**

An MT3334HD8 modem can operate as a 33,600 bps, 28,800 bps, 19,200 bps, 14,400 bps, 9600 bps, 4800 bps, 2400 bps, or 300 bps modem. Use the **#A** command to select the speed that the modem uses for initial handshaking and subsequent speed selection. The **#A** command does not control the originating rate of the modem (that is done by the modem baud rate command **\$MB**), but only the answer mode starting speed.

#A0 causes the modem to start at maximum speed, with fallback to 31,200 to 28,800 to 26,400 to 24,000 to 21,600 to 19,200 to 16,800 to 14,400 to 12,000 to 9600 to 4800 to 2400 to 1200 to 300 bps.

#A1 causes the modem to operate at maximum speed only.

#A2 causes the modem to start at maximum speed, with decremental fallback to 4800 bps.

#A3 causes the modem to start at 2400 bps in V.22bis mode, with fallback to 1200 to 300 bps.

Bn Answer Tone

$n = 0$ or 1
Default: **B0**

The **B** command selects the frequency the modem uses for its answer tone. (The answer tone is the tone a modem receiving a call transmits to the modem that called it, thus initiating the handshake between the two modems.) At higher speeds (2400 to 33,600 bps) there is no conflict, because all protocols use the Bell frequency of 2225 Hz. However, the ITU-T specification for V.22 has an answer tone frequency of 2100 Hz. This command is available only in International models.

B0 enables ITU-T frequencies including V.21 (300 bps) and V.23 (1200/75 bps).

B1 enables Bell frequencies including Bell 103 (300 bps).

%DC n AT Command Control $n = 0$ or 1

Default: %DC0

The %DC command allows you to disable the modem's ability to respond to AT commands. It can be used with auto answer applications in which no call origination is required, with some UNIX applications, and with other applications that require you to disable the modem's command mode.

%DC0 enables command mode.

%DC1 disables command mode.

Note: If you save %DC1 as part of your default configuration, you can re-enable command mode by typing AT%DC0 and pressing ENTER in the first ten seconds after you power up the modem.

&CD n Cleardown at Disconnect $n = 0$ or 1

Default: &CD0

In the V.32, V.32bis, and V.34 protocols, a cleardown is sent by one of the modems to signal the other modem that it is going to hang up. A cleardown is rate renegotiation in which the modem that is hanging up tells the other modem that it has no speeds that it can connect at. It is designed to help the remote modem detect a hang-up. However, it does take a second or two to send the cleardown. If you find this delay unacceptable, you can disable cleardown by using the &CD command.

&CD0 enables cleardown at disconnect.

&CD1 disables cleardown at disconnect.

>DT n DTMF Detection $n = 0$ or 1

Default: >DT0

Normally, when it goes off-hook, a fax modem ignores tones from the other end of the connection unless they are fax or modem handshake tones, in which case it responds in kind. The >DT1 command causes the modem to report DTMF (touch-tone) tones and fax calling tones to software for further processing. A typical use would be for a program that routes calls to specific communications applications depending on the type of call or upon a DTMF tone added to a dialing string.

>DT0 disables DTMF detection.

>DT1 enables DTMF detection when the modem goes off-hook.

#Fn Fallback Modes

n = 0, 1, or 2
Default: **#F2**

The **#F** command controls whether the modem will fall back to a lower speed because of an unacceptable error rate. If line conditions deteriorate, the modem has the ability to fall back from its original speed to the next lower speed when operating in V.34, V.32bis, or V.32 mode. If the error rate becomes too great, the modem performs a retrain at the next lower speed. If, after the retrain, the error rate is still too high, the modem performs a retrain at the next lower speed, down to 4800 bps.

If the modem returns online at the original speed after the first retrain, the modem starts a counter and a timer. If three retrains occur within a two-minute period, the modem falls back to 4800 bps.

The fallback and fall-forward speeds for the modem are 33.6K, 31.2K, 28.8K, 26.4K, 24.0K, 21.6K, 19.2K, 16.8K, 14.4K, 12K, 9.6K, and 4.8K bps.

#F0 (or **#F**) disables fallback when online.

#F1 lets the modem fall back from the starting speed to a low speed of 4800 bps in 2400 bps decrements.

#F2 lets the modem fall back when line conditions deteriorate, but also lets it fall forward in 2400 bps increments if line conditions improve.

&Gn Guard Tones

n = 0, 1, or 2
Default: **&G0** (models outside U.K.) or **&G2** (U.K. models only)

The **&G** command is used to control the presence or absence of guard tones from the transmitter when in answer mode at either 1200 or 2400 bps. Guard tones are used in Europe and other areas to allow the modem to function in the telephone systems. Guard tones are not used in the United States. U.K. models are locked at **&G2** (1800 Hz guard tone).

&G0 disables ITU-T guard tones.

&G1 enables ITU-T 550 Hz guard tone.

&G2 enables ITU-T 1800 Hz guard tone.

***Hn Busy-Out After Disconnect**

n = 0 or 1
Default: ***H0**

The ***H1** command causes the MT3334HD8 to remain out of service and return a busy signal until configuration from the CommPlete Communication Server's dedicated management console has finished. If no configuration option is set on the dedicated management console, the MT2834MR remains out of service for ten seconds after disconnect. Register **S94** controls the length of the out-of-service, or busy-out, time (see Chapter 4).

***H0** disables busy-out after disconnect.

***H1** enables busy-out after disconnect.

&Pn Set Pulse-Dial Ratios

n = 0 or 1
Default: **&P0** (Models outside U.K.) or **&P1** (U.K. models only)

The **&P** command sets the time ratios between the open (break) and closed (make) states of dialing pulses. U.K. models are locked to **&P1** (67:33 ratio). See Appendix B for more dial pulse information.

&P0 sets a pulse dial ratio of 60 ms break to 40 ms make.

&P1 sets a pulse dial ratio of 67 ms break to 33 ms make.

&RD n Square Wave Ring Detect

$n = 0$ or 1

Default: **&RD0** (U.K. and International models)

&RD1 (North American models)

The ring back sound that you hear when you dial a number is generated at the local telephone office or PBX. Normally, it is a sine wave analog tone. However, some PBXs generate square wave rings that can go undetected by normal ring detection circuits, resulting in a failure to make a connection. To enable your modem to detect square wave rings, use the **&RD1** command.

&RD0 enables sine wave ring detection only.

&RD1 enables sine wave and square wave ring detection.

\$T n Calling Tone

$n = 0$ or 1

Default: **\$T1**

The **\$T** command enables or disables the modem's calling tone, which is required by some European countries to identify the caller as a modem.

\$T0 enables the calling tone.

\$T1 disables the calling tone.

#T n Trellis-Coded Modulation

$n = 0$ or 1

Default: **#T1**

The **#T** command enables or disables trellis-coded modulation (TCM) on the modem. There is usually no need to disable TCM, except for an unusual line condition called impulse noise.

#T0 disables TCM.

#T1 enables TCM.

Yn Long Space Disconnect

n = 0 or 1

Default: **Y0**

When two modems are connected in reliable mode, a link disconnect request packet is sent to request a disconnect. In non-error correction mode, there is no “polite” way to request a disconnect. As a result, some “garbage” may be received when a hang-up command is issued.

Y0 disables the modem’s use of the break signal.

Y1 enables the modem’s use of the break signal, which shuts off the modem’s receiver and disconnects (both modems must have **Y1** enabled).

V.34 Commands

The following commands apply only in V.34 mode.

%Fn Echo Canceler Frequency Offset Compensation

n = 0 or 1

Default: **%F0**

The **%F** command enables and disables echo canceler frequency offset compensation which, when enabled, can decrease modem performance.

%F0 disables echo canceler frequency offset compensation.

%F1 enables echo canceler frequency offset compensation.

&RAn Asymmetric Bit Rate

n = 0 or 1

Default: **&RA0**

The **&RA** command enables or disables asymmetric bit rate operation in V.34 mode. The asymmetric bit rate feature lets the modem transmit at one rate while receiving at a different rate.

&RA0 enables asymmetric bit rate operation.

&RA1 disables asymmetric bit rate operation.

RS-232 Interface Commands

These commands define how an MT3334HD8 modem will use and respond to standard RS-232 signals.

&Cn Carrier Detect Control

$n = 0, 1, 2, \text{ or } 4$

Default: **&C1**

The **&C** command lets you control the Carrier Detect (CD) signal on the RS-232/V.24 interface. Normally, CD goes high when the modem detects a carrier on the communications link, and drops when it loses the carrier. By using **&C**, however, you can force the signal to stay high, or to drop momentarily when the remote modem disconnects. (This option is useful with some CBX phone systems and mainframe front ends, which require CD to act in this manner.) You can also force the modem to reset when the CD signal drops.

&C0 forces CD high.

&C1 allows CD to act normally—to go high when the modem detects a carrier, and to drop when it loses the carrier.

&C2 causes CD to drop for one second on disconnect, and then go high again. (If you want to set the drop time to something other than one second, change register **S24**.)

&C4 resets the modem when CD drops.

&Dn Data Terminal Ready Control

$n = 0, 1, 2, \text{ or } 3$

Default: **&D2**

The Data Terminal Ready (DTR) signal on pin 20 of the RS-232/V.24 interface must be high, or “on,” in order for the modem to operate. A high DTR signal tells the modem that the computer it is connected to is ready to communicate through the modem.

The DTR signal can also be used to cause the modem to reset to its default parameters, as if you had given the modem an ATZ command.

&D0 (or **&D**) causes the modem to ignore DTR.

&D1 causes the modem to hang up when DTR drops. While DTR is low, the modem accepts commands, but will not dial or auto-answer until DTR goes high again.

&D2 acts the same as **&D1**.

&D3 causes the modem to reset when DTR drops. It will also hang up if it is online.

&Rn Clear to Send Control

$n = 0, 1, \text{ or } 2$

Default: **&R1**

The **&R** command lets you control the state of the Clear to Send (CTS) signal on pin 5 of the RS-232/V.24 interface. Normally, CTS follows RTS when the modem is online. You have three choices. You can force the signal high, allow it to act normally, or set it to stay high until the modem disconnects, go low momentarily, and then go high again. The last option is useful with CBX phone systems and mainframe front ends that require CTS to act in this manner.

&R0 lets CTS act normally, that is, to follow RTS.

&R1 forces CTS high. When the modem goes online, CTS still provides flow control.

&R2 lets CTS drop on disconnect for the time set by register **S24**, then go high again.

&Sn Data Set Ready Control

$n = 0, 1, \text{ or } 2$

Default: **&S1**

Use the **&S** command to control the state of the Data Set Ready (DSR) signal on the RS-232/V.24 interface. Normally, DSR follows CD. You can force the signal high; allow it to act normally; or set it to stay high until the modem disconnects, go low momentarily, and then go high again.

&S0 forces DSR high.

&S1 allows DSR to act normally, that is, to follow CD.

&S2 sets up DSR so that it drops for one second on disconnect and then comes up again. (If you want to set the drop time to something other than one second, change register **S24**.)

&RFn CTS/RTS Interaction Control

$n = 0 \text{ or } 1$

Default: **&RF1**

In normal operation, Clear to Send (CTS) follows Request to Send (RTS) when the modem is online. In other words, if RTS goes off, CTS goes off. In some applications, however, it is necessary for CTS to operate independently of RTS.

&RF0 enables CTS to follow RTS.

&RF1 enables CTS to operate independently of the state of RTS. See the **&R** command for control of CTS.

&SFn DSR/CD Interaction Control

$n = 0 \text{ or } 1$

Default: **&SF0**

Normally, the Data Set Ready (DSR) signal follows the Carrier Detect (CD) signal. In other words, if CD goes high, DSR goes high. In some applications, however, it may be necessary for DSR to operate independently of CD.

&SF0 enables DSR to follow CD.

&SF1 enables DSR to operate independently of CD. For control of DSR, see the **&S** command.

Error Correction and Data Compression Commands

You can configure a modem to any of three different V.42 modes of operation (each mode can be with or without compression). They are the non-error correction, auto-reliable, and reliable modes. You can also turn data compression on or off.

&En Error Correction Modes

$n = 0, 1, \text{ or } 2$

Default: **&E1**

Select the modem's error correction mode using the **&E0**, **&E1**, or **&E2** command.

&E0 disables the modem's V.42 error correction capabilities, and the modem functions as a non-error correction modem.

&E1 enables auto-reliable mode. During the handshaking procedures at the start of the online connection, the modem queries whether the other modem is using V.42 error correction. If the modem determines that the other modem is using V.42, it switches itself into reliable (V.42) mode and enables error correction. If it determines that the other modem is not using V.42, the modem remains in non-error correction mode.

&E2 enables reliable mode, in which the modem uses its V.42 error correction capabilities for all transmissions. In reliable mode, the modem must be connected to a modem with a V.42 protocol (MNP or LAP-M).

The V.42 standard includes MNP Class 3 and 4 and LAP-M error correction methods. The V.42 mode select command (**#L**) selects which type of error correction the modem uses for transmissions.

&En Data Compression

$n = 14 \text{ or } 15$

Default: **&E15**

Data compression is normally enabled, providing **&E1** (auto-reliable mode) or **&E2** (reliable mode) has also been selected. However, you may wish to turn it off in certain circumstances.

&E14 disables data compression.

&E15 enables data compression.

#Ln V.42 Error Correction Modes

$n = 0-3$

Default: **#L0**

The **#L** command selects the V.42 error correction method (MNP or LAP-M) the modem uses when originating a call. In answer mode, the modem ignores the **#L** command and accepts whichever V.42 mode, MNP or LAP-M, the originating modem offers.

#L0 causes the modem to negotiate the V.42 error correction method with the answering modem, and to begin negotiation with LAP-M. If both modems have LAP-M capability, the modems will use LAP-M mode. If one or both modems do not have LAP-M capability and both have MNP, the modems will use MNP.

#L1 enables MNP error correction and disables LAP-M.

#L2 enables LAP-M error correction and disables MNP.

#L3 enables LAP-M error correction and disables MNP, but skips the V.42 detection phase used by the other commands. Both modems must be set with **#L3**.

\$En V.42 Error Correction at 300 bps

$n = 0$ or 1
Default: **\$E0**

At 300 bps, error correction is not normally used.

\$E0 disables 300 bps/V.42 error correction altogether.

\$E1 enables the modem to function at 300 bps in non-error correction (**&E0**), auto-reliable (**&E1**), or reliable (**&E2**) mode.

\$An Auto-Reliable Buffering

$n = 0$ or 1
Default: **\$A0**

In auto-reliable mode, the modem has four seconds to establish a reliable connection, after which the modem drops to non-error correction mode. Any data received during this period will normally be discarded. The **\$A** command causes the modem to buffer (store) data that is received during the auto-reliable time-out period. This data is then output by the modem after the **CONNECT** message.

\$A0 discards the data received during the auto-reliable time-out period.

\$A1 buffers data received during the auto-reliable time-out period.

\$Fn Auto-Reliable Fallback Character Enable/Disable

$n = 0$ or 1
Default: **\$F0**

In auto-reliable mode, the modem has four seconds to establish a reliable connection. If a single carriage return is received from the remote modem during this period, the auto-reliable modem assumes that the remote modem is not in reliable mode, and drops to non-error correction mode. The carriage return is the only character that causes the modem to drop to non-error correction mode. Any other data is either buffered or discarded.

Use the **\$F** command to enable this feature.

You can use the auto-reliable fallback character (**\$F**) and auto-reliable buffering (**\$A**) commands together to cause the modem to buffer all data received up until the carriage return, and then drop to non-error correction mode. All data received is then output following the **CONNECT** message.

\$F0 causes the modem not to fall back to non-error correction connect if a carriage return is received.

\$F1 causes the modem to fall back to non-error correction connect if a carriage return is received.

\$Rn Retransmit Count*n* = 0 or 1Default: **\$R0**

If errors are received during a reliable connection, the modem re-sends the block of data that contained an error. If another error occurs, it re-sends the block again. The modem counts the number of times that a data block is re-sent.

\$R0 causes the modem to disconnect if the same block of data is re-sent 12 times without being received properly, on the assumption that the line is unsuitable for transmission.

\$R1 causes the modem to disable the retransmit counter, so that the modem keeps trying to send data and will not abort, no matter how many times the same block is resent. Type **AT\$R0** to disconnect the modem if all attempts to re-send the block fail.

Speed Conversion Commands

Speed conversion allows the MT3334HD8 to communicate at a fixed speed through the serial port while communicating at an independent speed over the online communications link.

Speed conversion is necessary for data compression, since data compression requires data to be sent from the computer to the modem at a rate up to four times faster than the modem's transmission speed.

Speed conversion is also useful for an auto answer modem connected to a computer that does not have auto baud capability, since the computer must be set at a fixed baud rate regardless of the speed at which the modem communicates over the phone line.

\$BAn Baud Adjust*n* = 0 or 1Default: **\$BA0**

Even though the term "baud adjust" sounds like it should mean the same thing as "speed conversion," it actually means the opposite. Turning baud adjust off turns speed conversion on; turning baud adjust on turns speed conversion off.

When baud adjust is on, the modem matches its RS-232 serial port speed to any changes in the computer's serial port speed in originate mode, or to the speed of the originating modem when it's in answer mode. With baud adjust on, the speed at which the modem communicates over the phone line is always the same as the speed at which it communicates via its RS-232 serial port.

When speed conversion is on, the modem does not adjust its speed at the serial port to match its transmission speed. Serial port speed and transmission speed can therefore be set independently. Speed conversion is necessary for a high speed modem that is connected to a limited speed serial port.

\$BA0 turns baud adjust off and speed conversion on.

\$BA1 turns baud adjust on and speed conversion off.

\$MBn Modem Baud Rate

n = speed in bits per second
Default: **\$MB33600**

The **\$MB** command sets a modem's initial transmission speed for originate mode. In V.32 mode (9600 bps), it also sets the transmission speed for answer mode. With speed conversion on, this transmission speed can be different from the serial port speed.

When the modem answers a call from another modem, it automatically switches its transmission speed to match the calling modem. However, if the MT3334HD8 originates a call to another modem that is unable to connect at the transmission speed of the MT3334HD8, the MT3334HD8 will automatically drop to a lower speed in an attempt to match the speed of the other modem.

For example, if the MT3334HD8 is set for 14,400 bps and calls another modem that has a top speed of 2400 bps, it will drop to 2400 bps.

\$MB75	ITU-T V.23 mode
\$MB300	300 bps
\$MB1200	1200 bps
\$MB2400	2400 bps
\$MB4800	4800 bps
\$MB7200	7200 bps
\$MB9600	9600 bps
\$MB12000	12,000 bps
\$MB14400	14,400 bps
\$MB16800	16,800 bps
\$MB19200	19,200 bps
\$MB28800	28,800 bps
\$MB33600	33,600 bps (factory default)

Speed conversion must be on for this command to work. If baud adjust is on (**\$BA1**), speed conversion is off and a modem baud rate command will be ignored.

The **S48** register also can affect maximum transmission speed. See Chapter 4.

\$SBn Serial Port Baud Rate

n = speed
Default: **\$SB57600**

The **\$SB** command sets the speed of the MT3334HD8's serial port in both originate and answer modes. Speed conversion allows you to set this serial port baud rate at a fixed speed of up to 115,200 bps, regardless of the modem's transmission speed setting.

For this command to work, the modem's baud adjust feature must first be turned off with the **\$BA0** command. When baud adjust is on, as soon as the modem receives its first AT command, it automatically adjusts its serial port baud rate to match the speed of the computer or terminal to which it is connected. However, in applications such as automatic answer, the modem may not receive AT commands. In this case it is helpful to be able to preset the serial port baud rate with the **\$SB** command.

In addition to setting the modem's serial port speed, this command sets the speed at which the modem issues command mode responses (result codes).

The MT3334HD8 accepts AT commands at any speed, regardless of the speed preset by the **\$SB** command. If the modem receives a command at a speed different from the preset speed, the modem switches its serial port baud rate to match the new command speed, even though the baud rate value stored by the **\$SB** command remains the same. This provides you with a convenient way to switch the serial port speed while still making it easy to automatically return to the original speed the next time the modem is powered up or reset.

\$SB300	300 bps
\$SB1200	1200 bps
\$SB2400	2400 bps
\$SB4800	4800 bps
\$SB9600	9600 bps
\$SB19200	19,200 bps
\$SB38400	38,400 bps
\$SB57600	57,600 bps
\$SB115200	115,200 bps (factory default)

Immediate Action Commands

Use these commands to get information about AT commands and the current settings of the modem. For additional immediate action commands, see “Line Probe Commands” on page 41.

A/ Repeat Last Command

Default: None

Type **A/** to repeat the previous command. Do not precede this command with **AT** or press ENTER to execute it.

In Inquire Product Code

$n = 0, 1, \text{ or } 2$

Default: none

Some systems or software packages automatically check the identification of the modem by using the **I** command. Besides using it to check the modem ID, you can use the **I** command to check the version number of the modem’s built-in software, known as firmware.

ATI0 or **ATI** requests the modem’s ID number.

ATI1 requests the modem’s firmware version number. You can use this command to identify your modem’s firmware level when calling Technical Support.

ATI2 requests the product name, such as MT3334HD8.

ATI5 requests the digital signal processor version number.

L5, L7 List Current Operating Parameters

Default: none

The **L5** and **L7** commands cause your modem to list its current operating parameters. These lists are useful when you are changing communications software, or when you are changing modem default settings. All modem configuration parameters are listed.

ATL5 lists the modem’s current operating parameters.

ATL7 lists additional modem parameters.

L6 List Current S-Register Values

Default: none

ATL6 lists the current values in the modem’s S-registers. This information can be very useful if you wish to change S-register values.

L8 List Online Diagnostics

Default: none

The **L8** command displays the modem's online status. You can print this display and use it as a modem status report or as diagnostic information (such as when calling Technical Support).

If you type **+++ATL8** with the modem online, the current online status will be displayed. If you type **ATL8** with the modem in command mode, the most recent online status will be displayed. If you type **ATL8** immediately after modem power-up, the message `NO INFORMATION AVAILABLE` will be displayed.

To enter this command while online, type **+++ATL8<CR>**. Your modem's online status will be displayed, listing current operating conditions such as link type, line speed, serial speed, line quality, and reason for last disconnect.

&RN Rate Renegotiation

Default: none

The **&RN** command forces the modem to perform a rate renegotiation while online. To issue it, you must first escape to command mode by issuing the **+++AT<CR>** command.

&RR Retrain

Default: None

The **&RR** command forces the modem to perform an immediate retrain while online. To issue it, you must first escape to command mode by issuing the **+++AT<CR>** command.

Flow Control Commands

Flow control refers to the techniques used by data terminal equipment and the MT3334HD8 to pause and resume the flow of information between them. It prevents a device from accepting more data than it can handle. The MT3334HD8 implements flow control in both directions. When the MT3334HD8 halts the flow of data, it is called flow control, and when the computer halts the flow, it is called pacing.

&BS n Maximum Reliable Block Size

$n = 0$ or 1

Default: **&BS1**

When the modem is in reliable mode, use the **&BS** command to set the maximum size of a data block. MNP Class 3 sends a 64-character block, while Classes 4 and 5 normally send blocks of 256 characters or less. Reducing the block size for MNP 4 and 5 may improve overall throughput when phone lines are noisy; however, it also could slow data transfer if line quality is good.

&BS0 sets the maximum transmit block size to 64 characters.

&BS1 sets the maximum transmit block size to 256 characters.

\$EB n Asynchronous Word Length

$n = 0$ or 1

Default: **\$EB0**

The MT3334HD8 can operate with either a 10-bit format (one start bit, seven data bits, one parity bit, and one stop bit) or an 11-bit format (one start bit, eight data bits, one parity bit, and one stop bit) in both command and online modes.

\$EB0 enables a 10-bit format. It automatically detects parity when an AT command is issued.

\$EB1 enables an 11-bit format.

&E3 Flow Control Disable

The **&E3** command completely disables data flow control initiated by the modem.

&E4 Hardware Flow Control

Factory default. The **&E4** command enables the modem's use of the Clear to Send (CTS) signal on the RS-232/V.24 interface to regulate data flow. When CTS drops, data flow is suspended until the signal goes high again. This method of flow control works in conjunction with pacing (i.e., computer-initiated flow control), which uses the Request to Send (RTS) signal on the RS-232/V.24 interface. Hardware flow control cannot be enabled unless an active error correction protocol is selected.

&E5 XON/XOFF Flow Control

XON/XOFF flow control is an in-band method of data flow regulation used by the modem or computer (i.e., by flow control or pacing). If you issue the **&E5** command to the modem, it will respond to XON/XOFF pacing, and use XON/XOFF characters as its own method of flow control to the computer.

In-band data regulation means that the XON and XOFF characters (^Q and ^S, respectively) are inserted into the stream of data rather than using separate control lines. When an XOFF character is detected, the data stream is suspended until an XON character is detected. The drawback to using this method of pacing is that some files may contain these characters. If such a file is transferred using a modem, the file transfer can be suspended indefinitely.

&En XON/XOFF Pass-Through

n = 6 or 7

Default: **&E6**

When XON/XOFF pacing is active, the local modem has two options regarding the XON and XOFF characters. It can respond to and discard the characters from the computer, or it can respond to the characters and pass them through the datacomm link to the remote modem, thereby pacing the remote modem as well.

&E6 causes the modem to respond to and discard the XON and XOFF characters.

&E7 causes the modem to respond to the characters and pass them through the data link to the receiving modem.

&En Hewlett Packard ENQ/ACK Pacing

n = 8 or 9

Default: **&E8**

If the MT3334HD8 is used with Hewlett Packard (or compatible) equipment, it can be configured to respond to ENQ/ACK pacing as a complement to any other form of active flow control or pacing. In that case, pacing from the Hewlett Packard equipment is processed according to the HP protocol.

&E8 causes the modem to ignore ENQ/ACK pacing.

&E9 causes the modem to respond to the ENQ (^E) and ACK (^F) characters.

&En Non-Error Correction Mode Flow Control

n = 10 or 11

Default: **&E10**

When two modems are connected in non-error correction mode, XON/XOFF flow control can be used as a complement to XON/ XOFF pacing.

&E10 disables non-error correction mode flow control.

&E11 enables non-error correction mode flow control.

&En Pacing (Computer-Initiated Flow Control)

n = 12 or 13

Default: **&E13**

Pacing is the means by which the DTE (data terminal equipment—your computer or terminal) regulates the stream of incoming data. It is only enabled when the modem has some form of flow control active, such as RTS/CTS or XON/XOFF. When pacing is enabled, the modem responds to the DTE's pacing signals. When pacing is disabled, the modem ignores any pacing signals from the DTE.

&E12 disables pacing.

&E13 enables pacing.

#Xn Number of XOFF Characters Sent

n = 0 or 1

Default: **#X0**

The **#X** command allows the modem to send either a single or multiple XOFF characters when the modem's buffer becomes full. When the buffer is full, the next character received causes an XOFF character to be sent. In default mode, only one character is sent until the buffer reaches the XON level; however, it is also possible to send one XOFF character for every character received after the buffer is full.

#X0 causes only a single XOFF character to be sent after the buffer is full.

#X1 causes one XOFF character to be sent for every character received after the buffer is full.

Escape Sequences

Escape sequences are also known as escape codes. They are used to cause the modem to enter command mode from online mode without disconnecting the call. There are two local escape sequences used by the modem, `+++AT<CR>` and `<BREAK>AT<CR>`, and one remote escape sequence, `%%AT<CR>` (see “Remote Configuration.”).

`+++AT<CR>` In-Band Escape Sequence

If the modem is online with a remote modem, you can cause the modem to enter command mode, without disconnecting the call, by typing an escape code. The default escape code used by the modem is three plus signs (`+++`) followed by the letters `AT`, up to 10 command characters (most typically `H`, to hang up), and ENTER. The modem then escapes to command mode, executes the command (if any), and remains in command mode. For example, to hang up the modem at the end of a call, type `+++ATH <CR>`.

`<BREAK>AT<CR>` Out-of-Band Escape Sequence

The MT3334HD8 provides an alternate escape method that uses a break signal as the escape code. The break signal—ten or more zero bits issued by data communications software—allows the DTE to signal the modem without the risk of the modem interpreting data characters as modem control characters. The break signal is followed by the letters `AT`, up to 60 command characters, and ENTER. When this sequence is used, the modem executes the command and immediately returns to online mode, unless the command is to hang up and/or reset the modem (an `H` or `Z` command). In the latter case, the modem escapes to command mode after executing the `H` or `Z` command.

`%En` Escape Sequence Options

$n = 0-5$

Defaults: `%E1` and `%E4`

The default setting is for the modem to respond to the `+++` escape method. Optional settings are for the modem to respond to the `<BREAK>` method, for the modem to respond to either the `+++` or the `<BREAK>` methods, and for the modem to ignore both methods and not escape. The `%E` command is used to select these options as follows:

<code>%E0</code>	Modem won't escape
<code>%E1</code>	<code>+++ AT<CR></code> escape method (factory default).
<code>%E2</code>	<code><BREAK></code> escape method.
<code>%E3</code>	Either <code>+++</code> or <code><BREAK></code> escape methods.
<code>%E4</code>	Disables <code>OK</code> response to <code>+++</code> (factory default).
<code>%E5</code>	Enables <code>OK</code> response to <code>+++</code> .
<code>%E1 %E5</code>	Enables <code>+++</code> method and <code>OK</code> responses to <code>+++</code> .
<code>%E3 %E5</code>	Enables <code>+++</code> or <code><BREAK></code> method and <code>OK</code> responses to <code>+++</code> .

A Force Answer Mode

You can use the **A** command to force the modem into answer mode. Type `ATA` when in command mode to immediately bring your modem off-hook, out of command mode, and into online answer mode, and to cause it to transmit its carrier signal over the phone line. If no responding carrier tone is received by your modem within forty-five seconds (or by the time you have specified in register `S7`), your modem stops transmitting its tone, hangs up, and goes back into command mode.

O Go Back Online

You can use the **O** command to bring the modem out of command mode and back into online mode. The **O** command reverses the result of entering the escape code. The **O** command brings the modem into whichever online mode (originate or answer) that it was in prior to entering command mode.

Remote Configuration Commands

When you are online with another Multi-Tech modem, you can issue AT commands to it by sending a remote configuration escape sequence. The remote modem responds by displaying a menu and asking for a setup password. The MT3334HD8 has two default passwords. Please note that if you change them, you cannot retrieve them by resetting the modem by using **AT&W1**; you must know the new passwords to make any further changes. For further information on remote configuration, see Appendix F, “Remote Configuration.”

%%%AT<CR> Remote Configuration Escape Sequence

Enter the remote configuration escape sequence to initiate remote configuration when you are online with another Multi-Tech modem. The default escape sequence used by the MT3334HD8 is three percent signs (**%%%**) followed by the letters **AT** and ENTER. The remote configuration escape character, which is stored in register **S13**, can be changed either locally or remotely for greater security.

#lxxxxxx Change Login Password

xxxxxx = password
Default: **#IMULTI-TECH**

Use the **#I** command to enter or change the remote configuration login password.

AT#lxxxxxx enters the current remote configuration login password, where **xxxxxx** represents the password. If the password is wrong, the remote modem responds with **ERROR**; if it is correct, the remote modem responds with **OK**, and you can proceed with the **#S** command.

AT#I=xxxxxx stores a new remote configuration login password, where **xxxxxx** represents the password. The password is case sensitive, and can be any combination of upper and lower case keyboard characters. It must be six to ten characters in length.

#Syyyyyy Change Setup Password

yyyyyy = password
 Default: #SMODEMSETUP

Use the #S command to enter or change the remote configuration setup password. Before you can use it, you must enter the login password using the #I command.

AT#S*yyyyyy* enters the current remote configuration password, where *yyyyyy* represents the password. If the password is wrong, the remote modem responds with ERROR; if it is correct, the remote modem responds with OK, and you can proceed with the next command.

AT#S=*yyyyyy* stores a new remote configuration setup password, where *yyyyyy* represents the password. The password is case sensitive, and can be any combination of upper and lower case keyboard characters. It must be six to ten characters long.

Line Probe Commands

Before V.34 negotiation can take place, the local and the remote modem use modulated calling and answering tones to exchange information about their capabilities. If they can communicate in V.34 mode, they exchange probing signals to identify impairments in the telephone channel. Using the results of these line probes, they then set the communication parameters, including carrier frequencies and data rates, that they will use for the transmission. This process takes about five seconds. The following commands apply to the MT3334HD8 modems only when they are in V.34 mode.

%DP*n* Read Line Probe Data

n = 0 or 1
 Default: %DP0

Normally, the modem does not store data it acquires during the V.34 line probe. If you would like to examine the line probe data using the L9, L10, or L11 commands, you must first use the %DP1 command to instruct the modem to read and store the data.

%DP0 disables reading of line probe information during the handshake.

%DP1 enables reading of line probe information during the handshake.

%DF*n* Format Line Probe Data

n = 0 or 1
 Default: %DF0

This command selects whether line probe data will be displayed as a graph with the Y axis showing signal strength in dBm, or as a table with dBm values shown numerically. The graph format shows data in 150 Hz increments from 150 Hz to 3750 Hz, whereas the table format shows data in 75 Hz increments from 150 Hz to 3750 Hz.

%DF0 displays line probe data in graph format.

%DF1 displays line probe data in table format.

&RP Immediate Line Probe

Default: none

This immediate action command initiates a retrain that makes the processor read line probe information for display using the **L9**, **L10**, and **L11** commands. It is valid only when online in V.34 mode. Before issuing the command, you must escape to command mode while remaining online. To combine both actions, use the following command string: **+++AT&RP<CR>**.

The modem will not read and store the line probe information from this retrain unless you first issue a **%DP1** command

Ln Display Line Probe Data

n = 9–11

Default: none

These immediate action commands cause the modem to display line probe information when it is in V.34 mode. The line probe information must first be read and stored by the modem (see “Read Line Probe Data”). Data format is controlled by the Format Line Probe Data command, **%DF**.

The display commands are valid only in online mode. To use them online, you must first escape to command mode with **+++AT<CR>**. To return online, enter **ATO**.

ATL9 displays signal strength information.

ATL10 displays the signal to noise ratio (SNR).

ATL11 displays noise information.

Diagnostic Commands

The MT3334HD8 has two diagnostic commands and four diagnostic modes. The power-on self-test is activated every time power is applied. The **U** command selects a loopback test, while the **&T** command enables a modem to respond to a loopback test from another modem. See Chapter 5, “Testing the MT3334HD8,” for a fuller discussion. Refer to the **L8** command to see how to list the diagnostic online status.

&Tn Respond to Remote Digital Loopback Signal

n = 4 or 5

Default: **&T5**

The **&T** command enables or disables the modem’s ability to recognize the remote digital loopback (RDL) test signal. (See Chapter 5 for remote digital loopback test procedures.)

AT&T4 lets the modem respond to an RDL signal, and places it in digital loopback.

AT&T5 causes the modem to ignore the RDL signal.

Un Loopback Test Modes*n* = 0–3

Default: None

Loopback tests send data through the modem in such a way that it loops back to the terminal where it was entered, testing all the circuits along the way. The U command selects from several loopback tests. See Chapter 5, “Testing the MT3334HD8,” for more information.

ATU0 places the modem in originate mode for the local analog loopback test.

ATU1 places the modem in answer mode for the local analog loopback test.

ATU2 performs the remote digital loopback test.

ATU3 performs the local digital loopback test.

4 S-Registers

Introduction

This chapter describes the MT3334HD8's *S-registers*, which are small regions of memory where modem configuration information is stored. Whereas AT commands tell a modem *what* to do, S-registers tell the modem *how* or *when* to do it. Each S-register has a name that consists of the letter *S* and a number (**S0**, **S1**, **S2**, etc.), hence the term *S-register*. Use the **SR?** command to read the value stored in an S-register, and the **SR=*n*** command to change it.

S-Registers

S0 **Number of Rings Until Modem Answers**

Unit: 1 ring
Range: 0–255
Default: 1

S0 defines the number of rings the modem waits before answering an incoming call. The default value is one ring, which causes the modem to answer the call immediately after the first ring. The maximum number of rings that can be configured is 255. Setting the value to zero disables auto answer.

S1 **Ring Count**

Unit: 1 ring
Range: 0–255
Default: 0

S1 counts the number of rings that have occurred. It is a “read” type of register and is seldom, if ever, used in typical operation. Each time an incoming ring signal is detected, **S1** increases its value by one, up to a maximum of 255. If you set **S1** to a value other than its default value of zero, or if the value is increasing with rings, this new value remains stored in **S1** for eight seconds after the last ring is counted, after which the value reverts back to zero.

S2 **Escape Code Character**

Unit: Decimal
Range: 0–127
Default: 43 (+)

S2 defines the escape code character by its decimal ASCII code. The default character is the plus (+) sign (decimal 43). **S2** may be set for any ASCII character. Setting an **S2** value greater than 127 results in no escape character, and therefore no means of entering command mode from online mode without breaking the online connection, unless you use the BREAK method.

Note: If you change the **S2** value, you must make corresponding changes in your data communications software.

S3 **Return Character**

Unit: Decimal
Range: 0–127
Default: 13 (^M)

S3 defines the carriage return character by its decimal ASCII code. The default setting is the ^M character (decimal 13), which is the code for the ENTER key on most keyboards. **S3** may be set for any ASCII character.

Note: If you change the **S3** value, you must make corresponding changes in your data communications software.

S4 Line Feed Character

Unit: Decimal
Range: 0–127
Default: 10 (^J)

S4 defines the line feed character by its decimal ASCII code. The default setting is ^J (decimal 10), which is the code for the line feed key on most keyboards that have such a key. **S4** may be set for any ASCII character.

S5 Backspace Character

Unit: Decimal
Range: 0–127
Default: 8 (^H)

S5 defines the backspace character by its decimal ASCII code. The default setting is the ^H character (decimal 8), which is the code for the BACKSPACE key on most keyboards. **S5** may be set for any ASCII character.

Note: If you change the **S5** value, you must make corresponding changes in your data communications software.

S6 Wait Time for Dial Tone

Unit: 1 second
Range: 2–255 (North America), 4–255 (International), 4–7 (U.K.)
Default: 2 (North America), 4 (International and U.K.)

S6 defines the length of time the modem waits after the ENTER key is pressed before executing a dial command. The default setting is two seconds for North America, four seconds elsewhere.

S7 Time for Carrier (Abort Timer)

Unit: 1 second
Range: 1–255 (USA), 1–45 (Canada and International), or 1–55 (U.K.)
Default: 45 (North America and International) or 55 (U.K.)

S7 determines the abort timer delay time, which is the amount of time your modem will wait for a carrier signal before it disconnects. The default value is 45 seconds, except the U.K. model, for which it is 55 seconds. This means that, after dialing, the modem waits for a carrier signal for up to 45 or 55 seconds and, if none is detected, aborts the call. The maximum **S7** value is 255 seconds for the USA model, 45 seconds for Canadian and International models, and 55 seconds for the U.K. model.

S8 Pause Time for Comma

Unit: 1 second
Range: 0–255 (North America), 4–255 (International), 4–7 (U.K.)
Default: 2 (North America), 4 (International and U.K.)

S8 determines the length of the pause caused by a comma in a dialing command. The default setting is two seconds for the North American model, and four seconds for the International and U.K. models. **S8** may be set for up to 255 seconds. **S8** also defines the length of time the modem waits before retrying a call after it detects a busy signal. Some computer systems need more than two seconds to reset, in which case you should increase the value of **S8**.

S9 Carrier Detect Response Time

Unit: 100 ms
Range: 1–255
Default: 6

S9 determines the time delay between when the modem first detects a valid incoming carrier signal and when the modem turns on its Carrier Detect circuit. The default setting is 600 milliseconds (six units of 100 ms each). **S9** may be set for up to 25.5 seconds.

S10 Carrier Loss Disconnect Delay Time

Unit: 100 ms
Range: 1–254, 255
Default: 7

S10 defines the length of time after a loss of carrier signal before the modem disconnects. The default setting is 700 ms (seven units of 100 ms each). Maximum delay is 25.4 seconds (decimal 254). Setting the **S10** value to 255 causes the modem not to disconnect with loss of carrier.

S11 Tone Dialing Spacing and Duration

Unit: 1 ms
Range: 1–255 (USA) or 80–255 (Canada, U.K., International)
Default: 70 (USA) or 80 (Canada, U.K., International)

S11 sets the speed of tone dialing (spacing and tone duration times). The default value is 70 units for domestic models and 80 units for Canadian and International models, where each unit is one ms. In other words, for domestic modems, each tone is sustained for 70 ms followed by a 70 ms pause. The minimum **S11** value allowed by most telephone systems is 50 ms (50 units). Very few telephone systems can handle anything faster than that. The maximum **S11** value is 255 ms (255 units).

S13 Remote Configuration Escape Character

Unit: Decimal
Range: 0–127
Default: 37 (%)

S13 defines the remote configuration escape character by its decimal ASCII code. The **S13** default is the percent character (decimal 37). When you enter the **S13**-defined character three consecutive times from a remote site, your modem responds with its remote configuration procedure. A value of 0 disables remote configuration.

S17 Changing Break Time

Unit: 10 ms
Range: 1–255
Default: 25 (250 ms)

S17 defines the break time (space) the modem sends the DTE when it receives a break signal from a remote modem. Break duration is adjustable in 10 millisecond increments. The default is set to 25, for a 250 millisecond break.

S24 PBX/CBX Disconnect Drop Time for DSR/CTS/CD

Unit: 50 ms
Range: 0–255
Default: 20 (1 second)

Some PBX and CBX phone systems require the modem's DSR, CTS, and/or CD signals to drop briefly when calls are disconnected. The MT3334HD8's &R, &S, and &C commands can cause the modem to drop these signals for a specified time upon disconnect, and then bring the signals up again. S24 defines the length of time that the signals drop. The default setting of 20 results in a one-second drop time, which is what most PBX/CBX systems with this requirement need.

S25 DTR Dropout Time

Unit: 100 ms
Range: 0, 1–255
Default: 0 (50 ms)

S25 sets the amount of time that DTR must be dropped before the modem disconnects. Typically, a disconnect occurs when DTR is dropped for 50 milliseconds or more. This dropout time can be increased up to a maximum of 25.5 seconds. The S25 unit value for zero is 50 ms. For values from 1 through 255, the unit value is 100 ms.

S30 Inactivity Timer

Unit: 1 minute
Range: 0, 1–255 minutes
Default: 0 (disabled)

S30 can be used to cause the modem to disconnect if no data is transmitted or received for a specified time. S30 runs during both reliable and non-error correction connections. The timer restarts any time a data character passes through the serial port (either sent or received). If noise on the phone line causes an error to be received during non-error correction mode, this also will restart the S30 timer. The factory default of zero disables the timer.

S32 Time Lapse for Escape Sequence

Unit: 100 ms
Range: 0–255
Default: 20 (2 seconds)

S32 sets the time period to validate the escape sequence. If the S32 time interval expires before you press ENTER, then the escape sequence is aborted. The default is two seconds.

S34 Command Buffer Length After Online Escape Sequence

Unit: Decimal
Range: 0–60
Default: 10

Sets the number of characters allowed in an AT command after an in-band online escape (+++ method). If the number of characters after "AT" exceeds the S34 buffer length value, then the buffer is flushed and the escape sequence is aborted.

S36 DTR Busy-Out Time

Unit: 1 second
Range: 0–255
Default: 0 (disabled)

S36 sets the time between when DTR goes inactive and when the modem goes off-hook. The DTR busy-out feature is disabled when **S36** is set to 0.

Normally, when the DTR signal from the computer goes inactive, the modem goes on-hook after a time that is set by **S25**. If **S36** is set for a non-zero time, the modem then waits for the time set by **S36**; if DTR has not gone active again in that time, the modem goes off-hook, causing a busy signal for callers. The busy-out state ends when DTR goes active again.

S37 DTR Busy-In Time

Unit: 1 second
Range: 0–255
Default: 5

S37 sets the time between when DTR goes active and when the modem goes on-hook, if **S36** has caused it to go off-hook.

S43 Force V.34 Connect Speed

Unit: N/A
Range: 0, 33, 31, 28, 26, 24, 21, 19, 16, 14, 12, 96, or 48
Default: 0 (disabled)

S43 forces the modem to attempt to connect at a fixed speed in V.34 mode. The two-digit value corresponds to the first two digits of the speed (**S43=21** sets the connect speed to 21.6K bps, **S43=96** sets it to 9600 bps, etc.). The factory default of zero disables this feature and allows the modem to establish the best speed for the conditions.

Note: The **\$MB** command overrides **S43** if the **\$MB** command is set to a speed other than 33,600 bps.

S48 Maximum V.34 Connect Speed

Unit: N/A
Range: 0, 33, 31, 28, 26, 24, 21, 19, 16, 14, 12, 96, or 48
Default: 0 (disabled)

S48 sets the maximum speed in bps at which the modem can attempt to connect in V.34 mode. The two-digit value corresponds to the first two digits of the speed (**S48=26** sets the maximum connect speed to 26.4K bps, **S48=48** sets it to 4800 bps, etc.). This register allows you to set lower speeds for line conditions that will not support higher V.34 speeds such as 33.6K, 31.2K, 28K, 26.4K, or 24K. The factory default of zero disables this feature and allows the modem to establish the best speed for the conditions (in effect, it sets a maximum connection attempt of 33.6K).

S94 Out-of-Service Time

Unit: 1 second
Range: 0–254, 255
Default: 45

S94 sets the maximum number of seconds, from 0 through 254, that the modem remains out of service when the ***H1** command is active. A value of 255 causes the modem to remain out of service indefinitely. However, if the modem receives an enable command from the management program while the modem is out of service, the modem returns to service immediately, before the **S94** time expires.

Reading and Assigning S-Register Values

Use the **S** command to assign a value to an S-register and to read an S-register's current value.

To read an S-register value, in terminal mode, type **S**, the S-register number, and a question mark (**?**), and press **ENTER**. For example, to display the value of register **S7**, type **ATS7?** and press **ENTER**. The answer will appear as a three-digit decimal number (e.g., *045*).

To assign a new value to an S-register, type **S**, the S-register number, an equals sign (**=**), and a decimal number. Convert all ASCII characters to their decimal equivalents before entering them. S-register decimal values are 0–127 for ASCII characters, and 0–255 for numeric values. To make the change permanent, use the **&W0** command.

Examples of Assigning Values

1. Let's assume you want to have longer pauses caused by the comma in a dial command: five seconds instead of two. Type **ATS8=5** to assign 5 as the value for register **S8**. The modem will now pause five seconds for every comma in a dial command.
2. Or let's assume that you wish to configure the modem to answer incoming calls after the thirtieth ring instead of after the first ring. To configure register **S0** with a value of 30, type **ATS0=30** and press **ENTER**.
3. Or let's say you are calling long distance to another country code, and it is taking a long time to connect. The register **S7** (abort timer) factory default setting of 45 seconds is insufficient; the abort timer times out and cancels the call before a connection is made. To change the **S7** value to 55 seconds, type **ATS7=55** and press **ENTER**. Now, after dialing, the modem allows 10 more seconds for a carrier signal before aborting the call. The additional 10 seconds should provide enough time for international calls.

Examples of Reading Values

1. To verify that you entered the value correctly in the preceding examples, type **ATS8?** and press **ENTER** in the first example, **ATS0?** in the second example, and **ATS7?** in the third example. You should receive the responses *005*, *030*, and *055*, respectively.
2. When configuring S-registers, it is a good practice to include the verification read command in the same command string as the configuration assignment command. In the three preceding examples, type **ATS8=5S8?**, **ATS0=30S3?**, and **ATS7=55S7?**, respectively.

AT Commands that Affect S-Registers

For maximum throughput, the MT3334HD8's default configuration is for originating a call to another 33,600 bps modem that supports error correction, data compression, and flow control. If the receiving modem is not compatible, the MT3334HD8 can match any ITU-T or Bell standard modem (but not proprietary protocols).

If you require a different configuration for your application, for example, if you want to use an MT3334HD8 modem strictly as an auto answering device, or for service that does not support error correction, you can selectively change the command parameters and S-register values in active memory and save the new values by using the **&W** command.

The **&W0** (or **&W**) command stores all current AT command and S-register values into nonvolatile random access memory (NVRAM) and configures the modem so that it reads your custom settings in NVRAM when the modem is turned on or when it is reset with the Z command. (The **&F** reset command will continue to read the factory default settings in read-only memory [ROM] unless you also store the **&F9** command. See Chapter 3.) For convenience, you can include the **&W** command in the same command string that sets the new values in active memory, as in the following example:

```
AT&E2$SP1#L3$R0$MB19200$SB115200$EB1S0=10&W0<CR>
```

The **&W1** command erases your custom settings in NVRAM the next time the modem is turned off or reset, causing the modem to read the factory default settings in ROM when it is subsequently turned on or reset.

For further information on how the **&W** command interacts with the reset commands, see Table 2 on page 21.

Before you use the **&W** command, check the modem's current operating parameters by using the **L5**, **L6**, and **L7** commands.

5 Testing the MT3334HD8

Introduction

Each time you power up the MT3334HD8, it performs an automatic self-test to ensure proper operation. The MT3334HD8 also has three diagnostic tests: local analog loopback, digital loopback (remote/automatic), and digital loopback (local/manual). These ITU-T V.54 loopback tests isolate telephone circuit and transmission problems.

In a loopback test, data from your computer loops through the circuits of your modem and/or a remote modem before it appears on your monitor. When the loop has been completed, the data on your PC's monitor should match the original data.

The local analog loopback test allows you to verify that the modem's transmitter and receiver circuits are functioning properly.

The local digital loopback allows you to verify that the local computer or terminal, the two modems, and the transmission line between them are functioning properly.

The remote digital loopback test allows you to verify that the remote computer or terminal, the remote modem, the serial ports, the telephone line, and the local modem are functioning properly.

Note: All loopback tests operate at all speeds except 300 bps.

Other tests are initiated with the MultiModemManager software, as explained in the MultiModemManager *Owner's Manual*.

Local Analog Loopback Test (V.54 Loop 3)

In this test, data from your computer or terminal is sent to your modem's transmitter, converted into analog form, looped back to the modem's receiver, converted into digital form, and then sent to your monitor for verification. No connection to the phone line is required. See Figure 2.

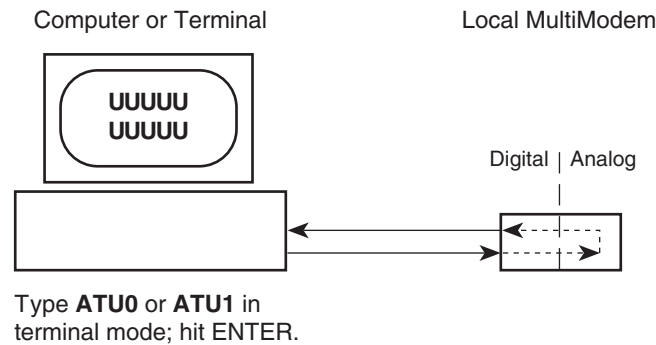

Figure 2. Local analog loopback test.

Test procedure

1. Connect the modem to your computer. Using your communication software, set the desired baud rate.
2. Type ATU or ATU0 and press ENTER. This places your modem in analog loopback mode in the originate mode. A CONNECT message should appear on your display. The modem is now out of command mode and in a pseudo-online mode.

3. Note that the CD LED is on. If you're set for 14,400 bps or higher, the Speed LED should be on. If the CD LED is not on, there is a defect in your modem.
4. Enter characters from your keyboard. For this test, typing multiple uppercase U characters is a good way to send an alternating test pattern of binary ones and zeros. The characters entered should be displayed on your monitor. The TD and RD LEDs should flash when a character is entered.
5. For a more complete test, you should also test the modem in answer mode. To do this, you must first terminate the originate mode by entering an escape sequence (`+++AT<CR>` or `<BREAK>AT<CR>`). An OK should appear on your display. Then type `ATU1` and press ENTER to place the modem in analog loopback in answer mode.
6. Note that the CD LED is on. If you're set for 14,400 bps or higher, the Speed LED should be on. If the CD LED is not on, there is a defect in your modem.
7. Enter characters from your keyboard. Type multiple uppercase U characters to send an alternating test pattern of binary ones and zeros. The characters entered should be displayed on your monitor. The TD and RD LEDs should flash when a character is entered.
8. To exit the test, enter an escape sequence (`+++AT<CR>` or `<BREAK>AT<CR>`), which returns the modem to command mode.
9. Your modem passes this test if the data received on your monitor are the same as the data entered from your keyboard. If different data appear on your monitor, your modem is probably causing the problem, though it could also be your computer. If your modem passes this test, but you are receiving errors while on line, the remote modem or the phone line could be at fault.

Remote Digital Loopback Test (V.54 Loop 2)

In this test, your modem must be online with another modem, such as another ZDX, that is set up to respond to a request for remote digital loopback. With the ZDX, this ability to respond is controlled by the `&T` command. `AT&T4` enables the response to remote digital loopback; `AT&T5` disables the response. The modem defaults to `&T5` on power-up, so this must be changed on the remote modem before initiating remote digital loopback.

Initiate remote digital loopback with the `ATU2` command, which places the remote modem in digital loopback mode. Data from your computer or terminal are transmitted through your modem and over the phone line to the remote modem, where they are then looped back to your modem. See Figure 3.

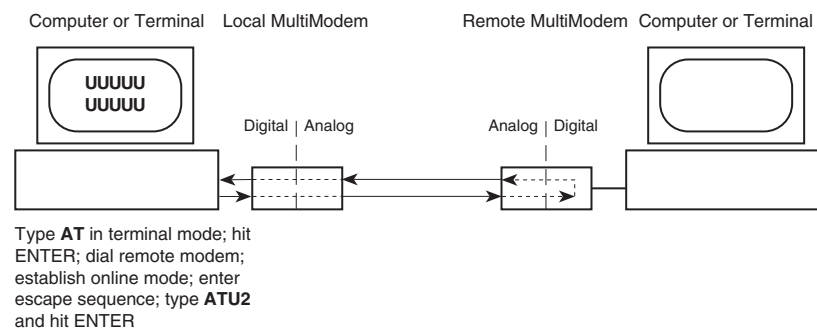

Figure 3. Remote digital loopback test.

Test procedure

1. Arrange to have `&T4` set on the remote test modem.

2. Open your communications software and go into terminal mode. Type **AT** and press ENTER; you should get an OK message. Type **AT&E0<CR>** to disable error correction.
3. Dial the remote modem and establish your online connection.
4. Type the escape sequence (**+++AT<CR>** or **<BREAK>AT<CR>**) to bring your modem into command mode while maintaining the connection with the remote modem.
5. Type **ATU2** and press ENTER. The local modem responds to this command by transmitting an unscrambled marking signal, which causes the remote modem to place itself in digital loopback mode. Then the local modem exits command mode and enters online mode.
6. Enter data from your keyboard. For this test, typing multiple uppercase *U* characters is a good way to send an alternating test pattern of binary ones and zeroes. Data received by the remote modem enters its analog receiver, is converted to digital data, is reconverted into analog, and then is transmitted back to your modem. Your modem passes this test if the data received on your monitor is the same as the data entered from your keyboard.
7. To exit the test, enter an escape sequence (**+++AT<CR>** or **<BREAK>AT<CR>**), which returns the modem to command mode. The modem should respond with an *OK* message. If you wish to stay on line with the remote modem for normal data transmission, type **ATO** and press ENTER. If you wish to terminate the call, type **ATH** and press ENTER to hang up.

Local Digital Loopback Test (V.54 Loop 2)

This test is identical to the remote digital loopback test with one exception. Instead of using your modem to signal a remote modem to place itself in digital loopback mode, your modem is placed in digital loopback mode while the remote modem is not. Data is entered and transmitted from the remote modem, sent across the phone line to the local modem, and looped back to the remote modem. See Figure 4.

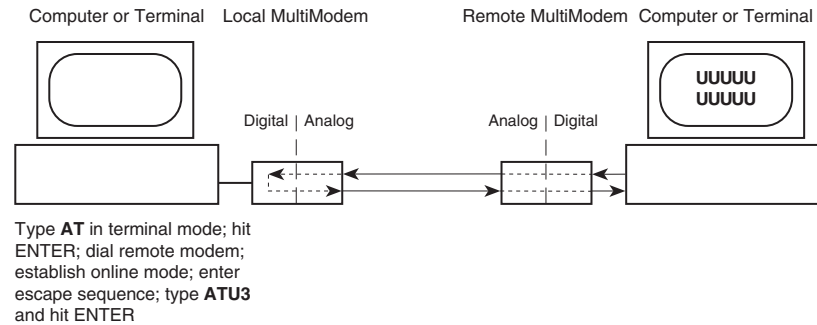

Figure 4. Local digital loopback test.

Test procedure

1. Open your communications software and go into terminal mode. Type **AT** and press ENTER; you should get an OK message. Enter **AT&E0<CR>** to disable error correction.
2. Dial the remote modem and establish your online connection.
3. Type an escape sequence (**+++AT<CR>** or **<BREAK>AT<CR>**) to bring your modem into command mode while still maintaining the connection with the remote modem.
4. Type **ATU3** and press ENTER. Once you receive an OK message from your modem (if responses are enabled), your modem is placed in digital loopback mode.
5. Have someone enter data from the remote keyboard. For this test, typing multiple uppercase *U* characters is a good way to send an alternating test pattern of binary ones and zeros. The data received by your modem enters its analog receiver, is converted to digital data, is reconverted into analog, and then is transmitted back to the remote modem. Your modem passes this test if the data received on the remote monitor is the same as the data entered from the remote keyboard.
6. To exit the test, enter an escape sequence (**+++AT<CR>** or **<BREAK>AT<CR>**), which returns the modem to command mode. The modem should respond with an OK message. If you wish to stay on line with the remote modem for normal data transmission, type **ATO** and press ENTER. If you wish to terminate the call, type **ATH** and press ENTER to hang up.

6 Warranty, Service, and Technical Support

Limited Warranty

Multi-Tech Systems, Inc. (“MTS”) warrants that this product will be free from defects in material or workmanship for a period of two years from the date of purchase, or, if proof of purchase is not provided, two years from date of shipment.

MTS MAKES NO OTHER WARRANTY, EXPRESSED OR IMPLIED, AND ALL IMPLIED WARRANTIES OF MERCHANTABILITY AND FITNESS FOR A PARTICULAR PURPOSE ARE HEREBY DISCLAIMED.

This warranty does not apply to any products which have been damaged by lightning storms, water, or power surges or which have been neglected, altered, abused, used for a purpose other than the one for which they were manufactured, repaired by the customer or any party without MTS’s written authorization, or used in any manner inconsistent with MTS’s instructions.

MTS’s entire obligation under this warranty shall be limited (at MTS’s option) to repair or replacement of any products which prove to be defective within the warranty period, or, at MTS’s option, issuance of a refund of the purchase price. Defective products must be returned by Customer to MTS’s factory, transportation prepaid.

MTS WILL NOT BE LIABLE FOR CONSEQUENTIAL DAMAGES AND UNDER NO CIRCUMSTANCES WILL ITS LIABILITY EXCEED THE PURCHASE PRICE FOR DEFECTIVE PRODUCTS.

Service

If your technical support specialist decides that service is required and you are outside the USA, your local distributor of Multi-Tech products usually offers the quickest and most economical repair option. If necessary, you may send your modem to our Mounds View factory in the USA. A modem that is shipped to us from outside the USA must have a Returned Materials Authorization (RMA) and shipping instructions. To return a modem for repair from inside the USA, no RMA is required; simply send it to us freight prepaid. Include a description of the problem, return billing and shipping addresses, a check or purchase order for out-of-warranty repairs, and, if possible the name of the technical support specialist you spoke to.

If you need to inquire about the status of the returned product, be prepared to provide its **serial number**.

Please send modems that require repairs to the following address:

Multi-Tech Systems, Inc.
2205 Woodale Drive
Mounds View, MN 55112
Attn: Repair

If you are shipping from outside the USA, please contact our Repair Department for an RMA prior to your shipment. You can contact us by telephone at +(612) 785-3500 or by fax at +(612) 785-9874.

Technical Support

Multi-Tech has an excellent staff of technical support personnel available to help you get the most out of your Multi-Tech product. If you have any questions about the operation of this unit, please call (800) 972-2439 (USA and Canada) or (612) 785-3500 (local and international). Please record MT3334HD8 information in the spaces provided below, and have it available when you call. If your MT3334HD8 requires service, the technical support specialist will guide you on how to send it in.

Recording Product Information

Please record the following information about your MT3334HD8 to help Technical Support answer your questions. (The same information is requested on the Warranty Registration Card.)

Model no.: _____

Serial no.: _____

Firmware version: _____

Driver version: _____

MultiModemManager software name and version _____

RASExpress software version _____

Datacomm software name and version: _____

FAX software version: _____

Other software version: _____

The modem model and serial numbers are silk-screened on your modem. The software versions are printed on the diskette labels. Type **ATI<CR>** in terminal mode to display the modem firmware version.

Please note the status of your modem in the space below before calling tech support. This includes LED indicators, screen messages, diagnostic test results, problems with a specific application, etc.

The Multi-Tech BBS

Multi-Tech maintains a bulletin board system (BBS) for its customers. Information available from the BBS includes new product information, product upgrade data, and problem-solving tips. There is also a message service that lets you request additional information. The phone number for the Multi-Tech BBS is (800) 392-2432 (USA and Canada) or (612) 785-3702 (local and international).

The BBS can be accessed by any asynchronous modem operating at 1200 bps to 33,600 bps at a setting of 8 bits, no parity, and 1 stop bit (8-N-1).

Logging onto the Multi-Tech BBS

To log on to the Multi-Tech BBS, perform the following steps:

1. Set your communications program to **8-N-1**.
2. Dial our BBS at (800) 392-2432 (USA and Canada) or (612) 785-3702 (international and local).
3. At the prompts, type your first name, last name, and password; then press **ENTER**. If you are a first time caller, the BBS will ask if your name is spelled correctly. If you answer yes, a questionnaire will appear. You must complete the questionnaire to use the BBS on your first call.
4. Press **ENTER** until the Main Menu appears. From the Main Menu you have access to three main areas: the Files Menu, the Message Menu, and Bulletins. For help on menu commands, type **?**.

Downloading a File

If you know the file name

1. From the Main Menu, type **F** to access the Files Menu, then type **D**.
2. Enter the name of the file you wish to download from the BBS.
3. If a password is required, enter the password.
4. Answer **Y** or **N** to the automatic logoff question.
5. Select a file transfer protocol by typing the indicated letter, such as **Z** for Zmodem (the recommended protocol).
6. If you select Zmodem, the transfer will begin automatically. If you select another protocol, you may have to initiate the transfer yourself. (In most datacomm programs, the **PAGE DOWN** key initiates the download.)

If you don't know the file name

1. From the Main Menu, type **F** to access the Files Menu. For a list of file areas, type **L** twice. (If you do not type the second **L**, you will list all of the files on the BBS.)
2. Mark the file areas you would like to examine by typing each file area's list number and pressing **ENTER**.
3. Enter **L** to list all the files in the selected file areas. Enter **C** to go forward in the file list and **P** to go back.
4. Mark one or more files for download by entering **M**, the list numbers of the files, and pressing **ENTER**.
5. Enter **D**. You will see a list of the files you have marked. Enter **E** if you would like to edit the list; otherwise enter **D** again to start the download process.

6. Select a file transfer protocol by typing the indicated letter, such as **Z** for Zmodem (the recommended protocol).
7. If you select Zmodem, the file will transfer automatically. If you select another protocol, you may have to initiate the transfer yourself. (In most communications programs, the PAGE DOWN key initiates the download.)
8. When the download is complete, enter **S** to return to the File Menu.

Reading a Message

When you log on, the BBS will tell you if you have a personal message (mail). At the prompt `Would you like to read it now?`, type **R** to read the message. This is the only point at which you can read your mail, since you cannot read any messages from the Message Menu.

Leaving a Message

The Multi-Tech BBS has no public discussion area. To leave a personal message, select the Message Menu by typing **M** at the Main Menu. Type **E**, then press ENTER to select the Sysop conference. Enter the name of the recipient (or "Sysop"), the subject, and the message text. Press ESC to finish, then type **S** to save the message and exit. To abort the message at any point, leave any of the fields blank and press ENTER.

Bulletins

When you log on, the BBS will ask if you would like to view the bulletin menu. The bulletins are menu-driven; to read a bulletin, enter its number. You can also access the bulletins by typing **B** at the Main Menu.

About CompuServe

In addition to the BBS, Multi-Tech provides support through CompuServe's Modem Vendor Forum (GO MODEMVEN) under GO MULTITECH. You can also download manuals, Help files, drivers, Microsoft Mail scripts, and product tips and descriptions from the forum's Multi-Tech library. Refer to your CompuServe documentation for special operating procedures.

About the Internet

Multi-Tech is a commercial provider on the Internet, and we retrieve e-mail messages from the following mailboxes on a periodic basis:

tsupport@multitech.com Technical Support

mtsmktg@multitech.com Marketing Dept.

mtssales@multitech.com Sales Dept.

international@multitech.com International Marketing & Sales

writers@multitech.com Publications Dept.

Multi-Tech's presence includes a Web site at:

http://www.multitech.com

and an ftp site at:

ftp://ftp.multitech.com

The ftp server mirrors the Multi-Tech BBS.

About the Multi-Tech Fax-Back Service

Multi-Tech's fax-back service provides 24-hour access to sales, marketing, and technical literature for customers in the USA. Dial (612) 717-5888, follow the voice prompts, and enter the document number for either the Sales and Marketing catalog or the Technical Support catalog of documents. For convenience, write your fax number in the following space: _____.

From the Sales and Marketing catalog, you can request to have newsletters, white papers, press releases, brochures, and other marketing literature faxed to you. From the Technical Support catalog, you can request basic modem operation information and troubleshooting guides. With either catalog, simply enter the FB Doc. number of the literature you wish to receive.

Upgrading the MT3334HD8 Firmware

The MT3334HD8's firmware is contained in a flash PROM. At various times, Multi-Tech may add enhancements and/or fixes to this firmware. The flash technology used in the MT3334HD8 allows these upgrades to be loaded directly into the PROM chip through the modem's serial port, or through the backplane when using the management software.

Please refer to the MultiModemManager software manual for instructions on how to update a modem's firmware using the management software.

Using FlashPro to Upgrade Firmware

1. Download FLASHPRO.ZIP and a new .HEX file from the Multi-Tech BBS.
2. Unzip the FLASHPRO.ZIP file. Place this unzipped file and the .HEX file in the same directory.
3. Run FlashPro by typing **flashpro** and pressing ENTER at the DOS prompt.
4. Highlight the **Configure** option in the **Main Menu**, and press ENTER. Highlight **Active Port** and select the COM port to which the MT3334HD8 is attached. Highlight **Baud Rate** and select the rate you want to program at. Press ESC when finished.
5. Highlight the **Select File to Program** option in the **Main Menu**. Highlight the .HEX file. Hit ESC when finished.
6. Highlight the **Program Firmware** option in the **Main Menu**. You are prompted to confirm the file to program.
7. Return to step 3, if you have not successfully programmed FlashPro, or call Multi-Tech's Technical Support or BBS.

Appendixes

Appendix A ASCII Conversion Chart

CTRL	CODE	HEX	DEC	CODE	HEX	DEC	CODE	HEX	DEC	CODE	HEX	DEC
@	NUL	00	0	SP	20	32	@	40	64	`	60	96
A	SOH	01	1	!	21	33	A	41	65	a	61	97
B	STX	02	2	"	22	34	B	42	66	b	62	98
C	ETX	03	3	#	23	35	C	43	67	c	63	99
D	EOT	04	4	\$	24	36	D	44	68	d	64	100
E	ENQ	05	5	%	25	37	E	45	69	e	65	101
F	ACK	06	6	&	26	38	F	46	70	f	66	102
G	BEL	07	7	'	27	39	G	47	71	g	67	103
H	BS	08	8	(28	40	H	48	72	h	68	104
I	HT	09	9)	29	41	I	49	73	i	69	105
J	LF	0A	10	*	2A	42	J	4A	74	j	6A	106
K	VT	0B	11	+	2B	43	K	4B	75	k	6B	107
L	FF	0C	12	,	2C	44	L	4C	76	l	6C	108
M	CR	0D	13	-	2D	45	M	4D	77	m	6D	109
N	SO	0E	14	.	2E	46	N	4E	78	n	6E	110
O	SI	0F	15	/	2F	47	O	4F	79	o	6F	111
P	DLE	10	16	0	30	48	P	50	80	p	70	112
Q	DC1	11	17	1	31	49	Q	51	81	q	71	113
R	DC2	12	18	2	32	50	R	52	82	r	72	114
S	DC3	13	19	3	33	51	S	53	83	s	73	115
T	DC4	14	20	4	34	52	T	54	84	t	74	116
U	NAK	15	21	5	35	53	U	55	85	u	75	117
V	SYN	16	22	6	36	54	V	56	86	v	76	118
W	ETB	17	23	7	37	55	W	57	87	w	77	119
X	CAN	18	24	8	38	56	X	58	88	x	78	120
Y	EM	19	25	9	39	57	Y	59	89	y	79	121
Z	SUB	1A	26	:	3A	58	Z	5A	90	z	7A	122
[ESC	1B	27	;	3B	59	[5B	91	{	7B	123
\	FS	1C	28	<	3C	60	\	5C	92		7C	124
]	GS	1D	29	=	3D	61]	5D	93	}	7D	125
^	RS	1E	30	>	3E	62	^	5E	94	~	7E	126
_	US	1F	31	?	3F	63	_	5F	95	DEL	7F	127

NUL	Null, or all zeros	VT	Vertical Tab	SYN	Sync.
SOH	Start of Header	FF	Form Feed	ETB	End Transmission Block
STX	Start of Text	CR	Carriage Return	CAN	Cancel
ETX	End of Text	SO	Shift Out	EM	End of Medium
EOT	End of Transmission	SI	Shift In	SUB	Substitute
ENQ	Enquiry	DLE	Data Link Escape	ESC	Escape
ACK	Acknowledge	DC1	Device Control 1	FS	File Separator
BEL	Bell or Alarm	DC2	Device Control 2	GS	Group Separator
BS	Backspace	DC3	Device Control 3	RS	Record Separator
HT	Horizontal Tab	DC4	Device Control 4	US	Unit Separator
LF	Line Feed	NAK	Negative Acknowledge	DEL	Delete

Appendix B Dial Pulses and Tones

Dial Pulses

When you pulse dial, as when you make a call with a rotary dial telephone, your telephone or modem generates codes in the form of pulses that simulate the opening and closing of old-fashioned electric relays, or switches. The number of pulses in a code are the same as the digit they encode; thus, the digit 1 is represented by one pulse, the digit 2 by two pulses, etc. In Figure B-1, the digit 2 is pulse dialed, followed by the digit 1. Each pulse consists of an A ms open (break) and a B ms closed (make), where A is either 60 or 67 ms, and B is either 40 or 33 ms, for a total of 100 ms per cycle, or a rate of 10 pulses per second. The interdigital pause time is 800 ms. The pulse ratios are controlled by the &P command.

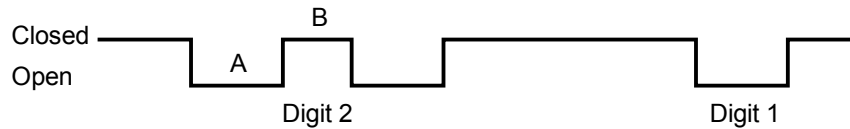

Figure B-1. Dial pulses

Tone Dial Frequencies

The tone dialing method combines two frequencies for each of the twelve digits found on a touch-tone dial pad. This method is referred to as dual-tone multi-frequency (DTMF) dialing.

The four horizontal rows on a touch-tone keypad use four low-frequency tones (697, 770, 852, 941 Hz), while the three vertical columns use three high-frequency tones (1209, 1336, 1477 Hz). The tone frequency tolerance is $\pm 0.02\%$.

For example, the digit 4 is dialed by combining two tone frequencies: 770 Hz from the second row, and 1209 Hz from the first column. In another example, the digit 9 is dialed with tone frequencies 852 Hz and 1477 Hz.

Hz	Digits		
697	1	2	3
770	4	5	6
852	7	8	9
941	*	0	#
Hz	1209	1336	1477

Figure B-2. Standard DTMF frequencies

The extended DTMF characters (A, B, C, D) are the high-end frequencies (1633 Hz) defined on some telephone sets with a fourth vertical column of buttons. This fourth column provides for extended PBX control functions. The actual functions that are provided depend on the PBX manufacturer's implementation and feature set.

Hz	Digits			
697	1	2	3	A
770	4	5	6	B
852	7	8	9	C
941	*	0	#	D
Hz	1209	1336	1477	1633

Figure B-3. Extended DTMF frequencies

Appendix C Result Code Summary

Multi-Tech Result Codes (&Q0)

Terse	Verbose	Definition
0	OK	Command was executed without error; ready for next command.
1	CONNECT	Modem has detected carrier and gone online.
2	RING	Modem has detected ring caused by incoming call.
3	NO CARRIER	No carrier signal has been detected within the allowed time.
4	ERROR	Error in command line (too many, or invalid characters).
5	CONNECT 1200	Modem has detected carrier at 1200 bps and gone online.
6	NO DIALTONE	No dial tone has been detected.
7	BUSY	A busy signal has been detected.
8	NO ANSWER	The remote system did not answer.
9	CONNECT 2400	Modem has detected carrier at 2400 bps and gone online.
10		Not used.
11	CONNECT 4800	Modem has detected carrier at 4800 bps and gone online.
12	CONNECT 9600	Modem has detected carrier at 9600 bps and gone online.
13	CONNECT 14400	Modem has detected carrier at 14400 bps and gone online.
19	CONNECT 19200	Modem has detected carrier at 19200 bps and gone online.
21	CONNECT 21600	Modem has detected carrier at 21600 bps and gone online.
23	CONNECT 1275	Modem is connected in V.23 mode.
24	CONNECT 24000	Modem has detected carrier at 24000 bps and gone online.
26	CONNECT 26400	Modem has detected carrier at 26400 bps and gone online.
28	CONNECT 28800	Modem has detected carrier at 28800 bps and gone online.
31	CONNECT 31200	Modem has detected carrier at 31200 bps and gone online.
33	CONNECT 33600	Modem has detected carrier at 33600 bps and gone online.

MNP Reliable Mode. If the modem connects using MNP error correction, the word RELIABLE or the letter R is added to the CONNECT responses as follows:

```

1R    CONNECT RELIABLE
5R    CONNECT 1200 RELIABLE
9R    CONNECT 2400 RELIABLE
11R   CONNECT 4800 RELIABLE
12R   CONNECT 9600 RELIABLE
13R   CONNECT 14400 RELIABLE
19R   CONNECT 19200 RELIABLE
21R   CONNECT 21600 RELIABLE
24R   CONNECT 24000 RELIABLE
26R   CONNECT 26400 RELIABLE
28R   CONNECT 28800 RELIABLE
31R   CONNECT 31200 RELIABLE
33R   CONNECT 33600 RELIABLE

```

LAP-M Reliable Mode. If the modem connects using LAP-M error correction, the word LAPM or letter L is added to the CONNECT responses as follows:

```
1L   Connect  LAPM
5L   Connect 1200 LAPM
9L   Connect 2400 LAPM
10L  Connect 4800 LAPM
12L  Connect 9600 LAPM
13L  Connect 14400 LAPM
19L  CONNECT 19200 LAPM
21L  CONNECT 21600 LAPM
24L  CONNECT 24000 LAPM
26L  CONNECT 26400 LAPM
28L  CONNECT 28800 LAPM
31L  CONNECT 31200 LAPM
33L  CONNECT 33600 LAPM
```

Data Compression. If the modem connects using data compression, the word COMPRESSED or the letter C is added to the CONNECT responses.

Standard AT Result Codes (&Q1)

If standard AT command set responses are selected by the &Q command, the following result codes change:

9		Not used.
10	CONNECT 2400	Modem has detected carrier at 2400 bps and gone online.

Appendix D S-Register Summary

Register	Unit	Range	Default	Description
S0	1 ring	0, 1–255	1	Sets the number of rings until the modem answers. ATS0=0 disables auto answer completely.
S1	1 ring	0–255	0	Counts the rings that have occurred.
S2	decimal	0–127	43 (+)	Sets ASCII code for the escape code character.
S3	decimal	0–127	13 (^M)	Sets ASCII code for the RETURN character.
S4	decimal	0–127	10 (^J)	Sets ASCII code for the LINE FEED character.
S5	decimal	0–127	8 (^H)	Sets ASCII code for the BACKSPACE character.
S6	1 sec	2–255 4–255† 4–7‡	2 4† 4‡	Sets the time the modem will wait for a dial tone before aborting a call.
S7	1 sec	1–255 1–45* 1–55‡	45 45* 55‡	Sets the time the modem will wait for a carrier signal before aborting a call.
S8	1 sec	0–255 4–255† 4–7‡	2 4† 4‡	Sets the length of the pause caused by a comma character in a dialing command.
S9	100 ms	1–255	6	Sets delay between when the modem detects a valid carrier signal and when it turns on its CD circuit.
S10	100 ms	1–254, 255	7	Sets how long a carrier signal must be lost before the modem disconnects. S10=255 causes the modem to not disconnect with loss of carrier.
S11	1 ms	1–255 80–255* 80–255‡	70 80* 80‡	Sets spacing and duration of dialing tones. 50 ms is the recommended minimum..
S13	decimal	0, 1–127	37 (%)	Sets ASCII code for remote configuration escape character. S13=0 disables remote configuration.
S17	10 ms	1–255	25	Sets the length of the break time (space) sent to the local PC when the modem receives a remote break.
S24	50 ms	0–255	20	Sets the time the DSR, CTS, and CD signals drop before going high again. Used for some PBX and CBX phone systems.
S25	100 ms	0, 1–255	0	Sets the time the DTR signal must be dropped before the modem disconnects. The 0 default equals 50 ms.
S30	1 min.	0, 1–255	0	Sets how long the modem waits after the last character is received or transmitted before it disconnects. The 0 default disables the timer.
S32	100 ms	0–255	20	Sets the time the modem will wait for a RETURN to be entered during escape sequence execution.
S34	1 character	0–60	10	Sets the number of command characters allowed after +++AT .
S36	1 sec	0, 1–255	5	Sets the time between DTR inactive and modem off-hook. S36=0 disables DTR busy-out.
S37	1 sec	0–255	5	Sets the time between DTR active and modem on-hook.

Register	Unit	Range	Default	Description
S43	decimal	33, 31, 28, 26, 24, 21, 19, 16, 14, 12, 96, or 48	0	Sets fixed V.34 connect speed. 28 = 28800 bps; 26 = 26400 bps; . . . 48 = 4800 bps. 0 default disables this feature.
S48	decimal	33, 31, 28, 26, 24, 21, 19, 16, 14, 12, 96, or 48	0	Sets maximum V.34 connect speed. 33 = 33600 bps; 31 = 31200 bps; . . . 48 = 4800 bps. 0 default disables feature (same as S48=33).
S94	1 sec	0–254, 255	45	Sets the maximum time the modem remains out of service when *H1 is active. S94=255 causes the modem to remain out of service indefinitely, until it receives an enable from the management software.

* Values for International and Canadian modems only.

† Values for International modems only.

‡ Values for UK modems only.

Appendix E AT Command Summary

Command	Values	Description
AT	n/a	Attention Code The attention code precedes all command lines except A/ , A: and escape codes.
RETURN	n/a	RETURN Key Press the RETURN (ENTER) key to execute most commands.
A	n/a	Force Answer Mode Answer call immediately without waiting for ring.
A/	n/a	Repeat Last Command Do not precede this command with AT. Do not press RETURN to execute.
A:	n/a	Continuous Redial Continuous redial of last number until answered. (10 redials in North American models. Not used on International or U.K. models.)
&An	n = 0 or 1	Answerback *** &A0 Answerback off. &A1 Answerback on.
\$An	n = 0 or 1	Auto-Reliable Buffering *** \$A0 Discard data received during establishment of reliable connection \$A1 Buffer data received during establishment of reliable connection
#An	n = 0–3	Auto Speed Detection in Answer Mode *** #A0 Start at maximum speed and fall back to 14400 to 12000 to 9600 to 4800 to 2400 to 1200 to 300 bps. #A1 Maximum speed only. #A2 Start at maximum speed and fall back incrementally to 4800 bps only. #A3 Start at 2400 bps and fall back to 1200 to 300 bps only.
Bn	n = 0 or 1	Answer Tone (International models only) *** B0 Select ITU-T V.21 answer tone. B1 Select Bell 103 answer tone.
&BSn	n = 0 or 1	Maximum Reliable Block Size &BS0 Maximum transmit block size of 64 characters. *** &BS1 Maximum transmit block size of 256 characters.

Command	Values	Description
\BAn$	$n = 0$ or 1	<p>Baud Adjust</p> <p>*** \$BA0 Set baud adjust off, speed conversion on. (Serial port speed is independent of modem data rate.)</p> <p>\$BA1 Set baud adjust on, speed conversion off. (Serial port speed is same as modem data rate.)</p>
&Cn	$n = 0, 1, 2,$ or 4	<p>Carrier Detect Control</p> <p>&C0 Force Carrier Detect on.</p> <p>*** &C1 Let Carrier Detect follow carrier signal.</p> <p>&C2 Let Carrier Detect drop for time set by S24 on disconnect, then go high again.</p> <p>&C4 Reset modem when Carrier Detect drops.</p>
&CDn	$n = 0$ or 1	<p>Cleardown at Disconnect</p> <p>*** &CD0 Enable cleardown.</p> <p>&CD1 Disable cleardown.</p>
Ds	$s =$ phone #	<p>Dial</p> <p>Dial telephone number s, where s may include up to 60 digits and the T, P, R, comma, colon, and semicolon characters.</p>
DsNd	$s =$ phone # $d = 0$ or 1	<p>Store Phone Number</p> <p>To store, enter D followed by telephone number s, then N followed by directory number d.</p>
&Dn	$n = 0, 1, 2,$ or 3	<p>Data Terminal Ready Control</p> <p>&D0 Modem ignores DTR signal.</p> <p>&D1 When DTR drops, the modem hangs up. While DTR is low, the modem accepts commands but will not dial or auto-answer until DTR goes high again.</p> <p>*** &D2 Same as &D1.</p> <p>&D3 When DTR drops, the modem hangs up and resets as if an ATZ or an AT&F command was issued.</p>
%DCn	$n = 0$ or 1	<p>Command Mode Control</p> <p>*** %DC0 Enable command mode.</p> <p>%DC1 Disable command mode.</p>
%DFn	$n = 0$ or 1	<p>Line Probe Data Format</p> <p>*** %DF0 V.34 line probe data displayed in graph format.</p> <p>%DF1 V.34 line probe data displayed in table format.</p>
%DPn	$n = 0$ or 1	<p>Line Probe Data Read</p> <p>*** %DP0 Disable reading of line probe data during the V.34 handshake.</p> <p>%DP1 Enable reading of line probe data during the V.34 handshake.</p>

Command	Values	Description
>DTn	<i>n</i> = 0 or 1	DTMF Detection *** >DT0 Disable DTMF detection. >DT1 Enable DTMF detection when off-hook.
En	<i>n</i> = 0 or 1	Echo Command Mode Characters E0 Do not echo command mode characters. *** E1 Do echo command mode characters.
&En	<i>n</i> = 0–15	V.42 Error Correction Modes &E0 Non-error correction mode (V.42 disabled). *** &E1 Auto-reliable mode. &E2 Reliable mode (V.42 enabled). Modem-Initiated Flow Control &E3 Flow control disabled. *** &E4 Hardware flow control. &E5 XON/XOFF flow control. XON/XOFF Pass-Through (&E5 selected) *** &E6 XON/XOFF not passed through. &E7 XON/XOFF passed through. Hewlett-Packard ENQ/ACK Pacing *** &E8 ENQ/ACK pacing off. &E9 ENQ/ACK pacing on. Non-Error Correction Mode Flow Control *** &E10 Non-error correction mode flow control off. &E11 Non-error correction mode flow control on. Pacing (Computer-Initiated Flow Control) &E12 Pacing off. *** &E13 Pacing on. Data Compression &E14 Data compression disabled. *** &E15 Data compression enabled.
\$En	<i>n</i> = 0 or 1	V.42 Error Correction at 300 bps *** \$E0 V.42 error correction at 300 bps disabled. \$E1 V.42 error correction at 300 bps enabled.
\$EBn	<i>n</i> = 0 or 1	Asynchronous Word Length *** \$EB0 10-bit mode enabled. \$EB1 11-bit mode enabled.

Command	Values	Description
%En	<i>n</i> = 0–5	<p>Escape Sequence Options</p> <p>%E0 Modem won't escape.</p> <p>*** %E1 +++ method</p> <p>%E2 Break method.</p> <p>%E3 Either +++ or break methods.</p> <p>*** %E4 No OK response to +++.</p> <p>%E5 OK response to +++.</p>
&Fn	<i>n</i> = 0, 8, or 9	<p>Load Default Configuration</p> <p>&F0 Load factory default values from ROM.</p> <p>*** &F8 Read factory default values and DIP switch settings when &F is issued.</p> <p>&F9 Read parameters stored in nonvolatile memory when &F is issued.</p>
\$Fn	<i>n</i> = 0 or 1	<p>Auto-Reliable Fallback Character Enable</p> <p>*** \$F0 Do not fall back to non-error correction mode connect if CR received.</p> <p>\$F1 Fall back to non-error correction mode connect if CR received.</p>
%Fn	<i>n</i> = 0 or 1	<p>Echo Canceler Offset Frequency Compensation</p> <p>*** %F0 Disable echo canceler offset frequency compensation.</p> <p>%F1 Enable echo canceler offset frequency compensation.</p>
#Fn	<i>n</i> = 0, 1, or 2	<p>Fallback Modes When Online</p> <p>#F0 No fallback when online.</p> <p>#F1 Fall back incrementally from maximum speed to 4800 bps.</p> <p>*** #F2 Fall back incrementally to 4800 bps, fall forward when line improves.</p>
&Gn	<i>n</i> = 0, 1, or 2	<p>Guard Tones (International model only)</p> <p>*** &G0 Turn off ITU-T guard tones.</p> <p>&G1 Turn on ITU-T 550 Hz guard tone.</p> <p>&G2 Turn on ITU-T 1800 Hz guard tone.</p> <p>Note: The U.K. model is locked to &G2, which turns on the ITU-T 1800 Hz guard tone.</p>
Hn	<i>n</i> = 0 or 1	<p>On-Hook/Off-Hook</p> <p>H0 Go on-hook (hang up).</p> <p>H1 Go off-hook.</p>
*Hn	<i>n</i> = 0 or 1	<p>Busy-Out After Disconnect</p> <p>*** *H0 Disable busy-out after disconnect.</p> <p>*H1 Enable busy-out after disconnect.</p>

Command	Values	Description
In	<i>n</i> = 0, 1, 2, or 5	Inquire Product Codes I0 Request modem ID #. I1 Request firmware revision #. I2 Request modem description. I5 Request DSP version.
#Ix	<i>x</i> = password	Enter Login Password Password is case sensitive.
#I=x	<i>x</i> = password	Store Login Password Password must be 6–10 characters long, and may consist of any keyboard characters.
Ln	<i>n</i> = 0, 5–11	List Commands L List stored telephone numbers. L5 List current operating parameters. L6 List current S-register values. L7 List additional parameters. L8 List online diagnostic parameters. L9 List line probe signal strength data. L10 List line probe signal to noise ratio. L11 List line probe noise data. Note: To use L9 , L10 , or L11 when online, you must first escape to command mode by typing +++ATLn<CR> (for <i>n</i> type 9 , 10 , or 11). Type ATO to return on line.
#Ln	<i>n</i> = 0, 1, 2, 3, or 8	V.42 Error Correction Mode *** #L0 Modems negotiate V.42 mode. #L1 MNP on and LAP-M off (originate mode only). #L2 LAP-M on and MNP off (originate mode only). #L3 Disable detection phase and go directly to LAP-M.
Mn	<i>n</i> = 0, 1, 2, or 3	Modem Speaker Control M0 Modem speaker always off. *** M1 Modem speaker on until carrier signal detected. M2 Modem speaker always on. M3 Monitor speaker on during dialing, off during handshaking.

Command	Values	Description
\$MBn	<i>n</i> = speed	Modem Baud Rate \$MB75 Select ITU-T V.23 mode. \$MB300 Select 300 bps on line. \$MB1200 Select 1200 bps on line. \$MB2400 Select 2400 bps on line. \$MB4800 Select 4800 bps on line. \$MB7200 Select 7200 bps on line. \$MB9600 Select 9600 bps on line. \$MB12000 Select 12,000 bps on line. \$MB14400 Select 14,400 bps on line. \$MB16800 Select 16,800 bps on line. \$MB19200 Select 19,200 bps on line. \$MB28800 Select 28,800 bps on line. *** \$MB33600 Select 33,600 bps on line.
Nd	<i>d</i> = 0 or 1	Dial a Stored Number Dial stored telephone number <i>d</i> .
NdNe...	<i>d</i> = 0 or 1 <i>e</i> = 1 or 0	Number Linking Dial stored number <i>d</i> ; if that is busy, dial stored number <i>e</i> . The command may be extended NdNeNdNe... to cycle between the two numbers.
O	n/a	Go Back On Line Exit command mode and go into online mode after using the escape code to do the reverse.
P	In dialing command	*** Pulse-Dial Modem pulse-dials numbers that follow P.
&Pn	<i>n</i> = 0 or 1	Set Pulse Dial Ratios *** &P0 60:40 pulse ratio. &P1 67:33 pulse ratio. Note: The ZDXK is locked to &P1 , a 67:33 ratio.
Qn	<i>n</i> = 0–2	Result Codes Enable/Disable *** Q0 Result codes sent. Q1 Result codes suppressed (quiet). Q2 No Response answer mode.
&Qn	<i>n</i> = 0 or 1	Result Codes (Multi-Tech or Standard AT) *** &Q0 Multi-Tech responses with modifiers. &Q1 Standard AT responses with no modifiers.
Rn	<i>n</i> = 0 or 1	Reverse Originate/Answer Mode *** R0 Modem will not reverse modes. R1 Modem will reverse modes when R is added to dial string.

Command	Values	Description
&Rn	$n = 0, 1, \text{ or } 2$	<p>Clear to Send Control</p> <p>&R0 Let CTS state follow RTS state when online.</p> <p>*** &R1 Force CTS high (on).</p> <p>&R2 Let CTS drop on disconnect for time set by S24, then go high again.</p>
&RAn	$n = 0 \text{ or } 1$	<p>Asymmetric Bit Rate</p> <p>*** &RA0 Enable asymmetric bit rate operation.</p> <p>&RA1 Disable asymmetric bit rate operation.</p>
&RDn	$n = 0 \text{ or } 1$	<p>Square Wave Ring Detect</p> <p>&RD0 Full wave ring detect only.</p> <p>*** &RD1 Full wave and square wave ring detect.</p>
&RFn	$n = 0 \text{ or } 1$	<p>CTS/RTS Interaction Control</p> <p>&RF0 Let CTS follow RTS.</p> <p>*** &RF1 Let CTS act independently.</p>
&RN	n/a	<p>Rate Renegotiation</p> <p>Forces the modem to renegotiate the data rate.</p>
&RP	n/a	<p>Immediate Line Probe</p> <p>Initiates a retrain that makes the modem read line probe information if %DP1 is selected. Valid only when online in V.34 mode.</p>
&RR	n/a	<p>Retrain</p> <p>Initiates an immediate retrain without a line probe reading.</p>
\$Rn	$n = 0 \text{ or } 1$	<p>Retransmit Count</p> <p>*** \$R0 Disconnect after 12 retransmits.</p> <p>\$R1 Do not disconnect after 12 retransmits.</p>
Sr=n	$r = 0-11, 13, 24, 25, 30, 32, 34, 36, 37, 43, 48, \text{ or } 94; n \text{ varies}$	<p>Set Register Value</p> <p>Set value of S-register r to value of n, where n is entered in decimal format.</p>
Sr?	$r = 0-11, 13, 24, 25, 30, 32, 34, 36, 37, 43, 48, \text{ or } 94$	<p>Read Register Value</p> <p>Read value of S-register r and display value in 3-digit decimal form.</p>
&Sn	$n = 0, 1, \text{ or } 2$	<p>Data Set Ready Control</p> <p>&S0 Force DSR high (on).</p> <p>*** &S1 Let DSR follow CD.</p> <p>&S2 DSR drops on disconnect for time set by S24, then goes high again.</p>

Command	Values	Description
&SF<i>n</i>	<i>n</i> = 0 or 1	<p>DSR/CD Interaction Control</p> <p>*** &SF0 Select DSR to follow CD. &SF1 Select DSR to be independent.</p>
\$SB<i>n</i>	<p><i>n</i> = speed Baud Adjust (\$BA) must be off.</p>	<p>Serial Port Baud Rate</p> <p>\$SB300 Select 300 bps at serial port. \$SB1200 Select 1200 bps at serial port. \$SB2400 Select 2400 bps at serial port. \$SB4800 Select 4800 bps at serial port. \$SB9600 Select 9600 bps at serial port. \$SB12000 Select 12,000 bps at serial port. \$SB19200 Select 19,200 bps at serial port. \$SB38400 Select 38,400 bps at serial port. \$SB57600 Select 57,600 bps at serial port. *** \$SB115200 Select 115,200 bps at serial port.</p>
#S<i>y</i>	<i>y</i> = password	<p>Enter Setup Password Password is case sensitive.</p>
#S=<i>y</i>	<i>y</i> = password	<p>Store Setup Password Password must be 6–10 characters long, and may consist of any keyboard characters.</p>
T	In dialing command	<p>Tone-Dial Modem tone-dials numbers following the T.</p>
&T<i>n</i>	<i>n</i> = 4 or 5	<p>Respond to Remote Digital Loopback Signal</p> <p>&T4 Enable response to remote digital loopback signal. *** &T5 Disable response to remote digital loopback signal.</p>
\$T<i>n</i>	<i>n</i> = 0 or 1	<p>Calling Tone</p> <p>\$T0 Enable calling tone. *** \$T1 Disable calling tone.</p>
#T<i>n</i>	<i>n</i> = 0 or 1	<p>Trellis-Coded Modulation</p> <p>#T0 Disable trellis-coded modulation. *** #T1 Enable trellis-coded modulation.</p>
U<i>n</i>	<i>n</i> = 0–3	<p>Loopback Test Modes</p> <p>U0 Enable analog loop originate mode. U1 Enable analog loop answer mode. U2 Enable remote digital loopback mode. U3 Enable local digital loopback mode.</p>
V<i>n</i>	<i>n</i> = 0 or 1	<p>Result Codes (Verbose/Terse)</p> <p>V0 Result codes sent as digits (terse response). *** V1 Result codes sent as words (verbose response).</p>

Command	Values	Description
#Vn	<i>n</i> = 0 or 1	<p>V.32terbo Handshake</p> <p>*** #V0 Enable V.32terbo tones in answer mode. #V1 Disable V.32terbo tones in answer mode.</p>
W	In dialing command	<p>Wait for New Dial Tone</p> <p>Causes modem to wait for new dial tone. (X2 or X4 must be selected.)</p>
&Wn	<i>n</i> = 0 or 1	<p>Store Configuration</p> <p>&W0 Store current settings in NVRAM; modem will load these at power-on or with the ATZ command instead of reading factory ROM defaults. *** &W1 Do not store settings.</p>
Xn	<i>n</i> = 0–4	<p>Result Codes and Call Progress Selection</p> <p>*** X0 Basic result codes (CONNECT only); does not look for dial tone or busy. X1 Extended result codes (w/ CONNECT 1200, CONNECT 2400, etc.); does not look for dial tone or busy signal. X2 Extended result codes with NO DIAL TONE; does not look for busy signal. X3 Extended result codes with BUSY; does not look for dial tone. X4 Extended result codes with NO DIAL TONE and BUSY.</p>
#Xn	<i>n</i> = 0 or 1	<p>Number of XOFF Characters Sent</p> <p>*** #X0 Single XOFF character sent after buffer is full. #X1 Multiple XOFF characters sent (one for every character received after buffer is full).</p>
Yn	<i>n</i> = 0 or 1	<p>Long Space Disconnect</p> <p>*** Y0 Disable sending or responding to long space break signal on disconnect. Y1 Enable sending or responding to long space break signal on disconnect. (Both modems must have Y1 set.)</p>
Z	n/a	<p>Modem Reset</p> <p>Reset modem to default values. Defaults come from NVRAM if &W0 is set, from ROM if &W1 is set.</p>
,	In dial command	<p>Dialing Pause</p> <p>Comma; causes dialing pause for time set by S8.</p>
:	At end of dial command	<p>Continuous Redial</p> <p>Colon; causes continuous redial of number until answered (10 in North American models). Not used in U.K. or International models.</p>

Command	Values	Description
;	At end of dial command	Return to Command Mode After Dialing Semi-colon; causes immediate return to command mode after dialing.
!	In dial command	Flash On-Hook Exclamation; causes modem to flash on-hook.
@	In dial command	Quiet Answer Causes modem to wait for a ringback, then 5 seconds of silence before processing next part of command.
\$	In dial command	Call Card Tone Detect Causes modem to wait for a call card tone before processing next part of command.
+++AT<CR>		Escape Sequence Puts modem in command mode while still remaining on line. Type +++ followed by the letters A and T , up to ten command characters (or as defined by S34), and a RETURN.
<BREAK>AT<CR>		Break Escape Sequence Alternate escape method. Puts modem in command mode while still remaining on line. Enter break signal followed by the letters A and T , up to sixty command characters, and a RETURN.
%%%AT<CR>		Remote Configuration Escape Sequence Cause remote modem to display remote configuration menu. Type %%% (or as defined in register S13) followed by the letters A and T , and a RETURN.

- * Factory default on International model
- ** Not available on U.K. model
- *** Factory default on North American model

Appendix F Remote Configuration

Introduction

Remote configuration, a feature of Multi-Tech's MT3334HD8 modems, is a network management tool that allows you to configure modems anywhere in your network from one location. With password-protected remote configuration, you can issue AT commands to a remote Multi-Tech modem for maintenance or troubleshooting as if you were on site.

Basic Procedure

The following steps are valid regardless of whether the connection is established by the local or the remote Multi-Tech modem.

1. Establish a data connection with a remote modem that has the remote configuration feature.
2. Send three remote configuration escape characters followed by **AT** and an ENTER. Example: **%%AT<CR>**. The remote modem responds with the following menu:

```
1. DATA Mode
2. COMMAND Mode
```
3. Enter the number **2**. The remote modem responds with a request for the setup password:

```
Password>
```
4. Enter your setup password. If the password is correct, the remote modem responds with:

```
OK
```
5. You can now send AT commands to the remote modem.
6. When you have finished configuring the remote modem, save the new configuration by typing **AT&W0<CR>**, then type **ATO<CR>** to exit remote configuration. The modem responds with the following menu:

```
1. DATA Mode
2. COMMAND Mode
```
7. Type the number **1** to return to data mode. You can then break the connection in the normal way.

CAUTION: If you hang up while you are in remote configuration mode, it may lock up the remote modem.

Setup

The first time you configure a modem remotely, you should set its passwords and possibly its remote configuration escape character. Multi-Tech modems are shipped with a default login password (MULTI-TECH) and setup password (MODEMSETUP). Because anyone who has an owner's manual knows the default passwords, for security you should change them—but don't forget them!

Changing the Passwords

1. Establish a remote configuration link with the remote modem as described above.
2. Type **AT#IMULTI-TECH** (or **AT#Lxxxxxx** if you have replaced the **MULTI-TECH** password with **xxxxxx**) and press **ENTER**. The modem responds with **OK** if the login password is correct, and **ERROR** if it is wrong.
3. Type **AT#SMODEMSETUP** (or **AT#Syyyyyy** if you have replaced the **MODEMSETUP** password with **yyyyyy**) and press **ENTER**. The modem responds with **OK** if the setup password is correct, and **ERROR** if it is wrong.
4. To change the login password, type **AT#I=xxxxxx**, where **xxxxxx** stands for the password, and press **ENTER**. The password may include any keyboard characters, but must be six to ten characters long. The modem responds with **OK**.
5. To change the setup password, type **AT#S=yyyyyy**, where **yyyyyy** stands for the password, and press **ENTER**. The password may include any keyboard characters, but must be six to ten characters long. The modem responds with **OK**.
6. The new passwords are saved automatically. You may now either enter more AT commands or exit remote configuration with **ATO<CR>**. The next time you remotely configure the modem you must use the new setup password.

Note: Passwords are case sensitive. The next time you enter the password, it must be in the same case as you set it up.

Changing the Remote Escape Character

To increase security, you may wish to change the remote modem's remote configuration escape character. The remote configuration escape character is stored in register **S13**. The factory default is 37, which is the ASCII code for the percent character (%). Setting **S13** to 0 (zero) will disable remote configuration entirely—but if you do this remotely, you won't be able to change it back remotely!

1. Establish a remote configuration link with the remote modem as described above.
2. Type **ATS13=n**, where **n** is the ASCII code for the new remote configuration escape character, then press **ENTER**.
3. Save the new value by typing **AT&W** and pressing **ENTER**.
4. Type **ATO<CR>**, then **1**, to exit remote configuration.

Index

A

- abort timer, 12, 19, 47, 51
- Answer command, 12, 40
- answer mode, 18, 34, 40
- Answer Tone command, 24
- Answerback command, 24
- answering a call, 40, 51
- ASCII code, 68
- Asymmetric Bit Rate command, 28
- Asynchronous Word Length command, 37
- AT Command Control command, 12, 25
- AT commands
 - attention code, 12, 13
 - command string limit, 13
 - disabling command mode, 12, 25
 - parameters, 13
 - summary, 75
- A, 12, 40
- A/, 35
- A:, 16
- AT, 12, 13
- B, 24
- D, 12, 16
- D...N..., 19, 20
- E, 22
- H, 16
- I, 35, 61
- L, 20
- L5, 35, 52
- L6, 36, 52
- L7, 35, 52
- L8, 36, 42
- L9, 42
- L10, 42
- L11, 42
- N, 20
- N...N..., 20
- O, 40
- P, 17
- Q, 22
- R, 18
- S?, 51
- S=, 51
- T, 17
- U, 43
- V, 23
- W, 17
- X, 17, 18, 23
- Y, 28
- Z, 22
- &A, 24
- &BS, 36
- &C, 29, 49
- &CD, 25
- &D, 29
- &E0, 31
- &E1, 31
- &E2, 31
- &E3, 37
- &E4, 37
- &E5, 37
- &E6, 37
- &E7, 37
- &E8, 38
- &E9, 38
- &E10, 38
- &E11, 38
- &E12, 38
- &E13, 38
- &E14, 31
- &E15, 31
- &F, 21, 52
- &G, 26
- &P, 27, 69
- &Q, 23, 71, 72
- &R, 30, 49
- &RA, 28
- &RD, 27
- &RF, 30
- &RN, 36
- &RP, 42
- &RR, 36
- &S, 30, 49
- &SF, 30
- &T, 42, 55
- &W, 20, 21, 22, 51, 52
- \$, 19
- \$A, 32
- \$BA, 33, 34
- \$E, 32
- \$EB, 37
- \$F, 32
- \$MB, 24, 34
- \$R, 33
- \$SB, 34
- \$T, 27
- #A, 24
- #F, 26
- #I, 40
- #L, 31
- #S, 41
- #T, 27
- #X, 38
- %%%AT<CR>, 40
- %DC, 12, 25
- %DF, 41, 42
- %DP, 41

%E, 39
 %F, 28
 >DT, 25
 *H, 26, 51
 ! (exclamation mark), 18
 , (comma), 18, 48
 : (colon), 16, 18
 ; (semicolon), 18
 @, 19
 +++AT<CR>, 39
 <BREAK>AT<CR>, 39
 auto answer, 12, 33, 46, 51
 disabling, 46
 Auto Speed Detection command, 24
 Auto-Reliable Buffering command, 32
 Auto-Reliable Fallback Character command, 32
 auto-reliable mode, 31, 32
 Auto-Reliable Mode command, 31

B

backspace character, 13, 47
 Baud Adjust command, 33
 baud rate
 modem, 34
 serial port, 33, 34
 BBS, Multi-Tech, 62
 Bell standards, 24
 blind dialing, 16, 20, 23
 break signal, 28, 49
 escape sequence, 39
 busy signal, 16, 18, 19, 20, 23, 26, 48
 Busy-Out After Disconnect command, 26, 51
 busy-out state, 2

C

Call Card Tone Detect command, 19
 Calling Tone command, 27
 Canadian Limitations Notice, iv
 carriage return character, 47
 Carrier Detect Control command, 29
 carrier, loss of, 48
 CBX phone systems, 29, 30, 49
 CC9600 chassis, 8, 9
 CD signal, 2
 control of, 29
 disconnect drop time, 49
 interaction with DSR signal, 30
 LED indicator, 55
 response time, 48
 Clear to Send Control command, 30
 Cleardown at Disconnect command, 25
 comma, 48

command buffer, 13, 50
 command mode, 12
 disabling, 12, 25
 command mode control, 25
 command string, 12, 19
 CompuServe, 63
 configuration, remote, 85
 Continuous Redial command, 16, 18
 CTS signal
 control of, 30
 disconnect drop time, 49
 flow control, 37
 interaction with RTS signal, 30
 CTS/RTS interaction control, 30

D

DAA, 2
 data bit, 37
 data compression and speed conversion, 33
 Data Compression command, 31
 Data Set Ready Control command, 30
 Data Terminal Ready Control command, 29
 diagnostic commands, 42
 Dial a Stored Number command, 20
 Dial command, 12, 16
 dial tone, 16
 wait time, 23, 47
 dialing
 a phone number, 16
 a stored number, 20
 blind dialing, 16, 20, 23
 continuous redialing, 16
 modifiers, 17
 pause time, 18, 48, 51
 smart dialing, 16, 23
 Dialing Pause command, 18
 dimensions of MT3334HD8, 6
 disconnecting, 33
 after DTR drop, 49
 drop time, 29, 30, 49
 inactivity timer, 49
 Display Line Probe Data command, 42
 DSR signal
 control of, 30
 disconnect drop time, 49
 interaction with CD signal, 30
 DTE (data terminal equipment), 38
 DTMF (dual tone multifrequency)
 detection, 25
 dialing, 17
 frequencies, 69
 DTMF Detection command, 25
 DTR signal

- busy-in time, 50
- busy-out time, 50
- control of, 29
- disconnect drop time, 49

E

- Echo Canceler Frequency Offset Compensation command, 28
- Echo Command Mode Characters command, 22
- ENQ/ACK Pacing command, 38
- error correction
 - at 300 bps, 32
 - automatic, 31
 - disabling, 31
 - selecting, 31, 32
- Error Correction Modes command, 31
- escape code character, 46
- Escape Sequence Options command, 39
- escape sequences
 - +++AT<CR>, 39
 - <BREAK>AT<CR>, 39
 - options, 39
 - remote configuration, 40
 - timeout, 49
- Extended codes, 23

F

- fallback, 24, 26
- Fallback Modes command, 26
- fax warning, iv
- fax-back service, 64
- FCC regulations, iii, 2
- Flash On-Hook command, 18
- FlashPro, 64
- flow control, 30, 36, 37, 38
 - commands, 36
 - CTS/RTS enable, 37
 - disabling, 37
 - non-error correction mode, 38
 - XON/XOFF pass through, 37
- Flow Control Disable command, 37
- Format Line Probe Data command, 41, 42
- front panel, 8
- fuses, 6

G

- Go Back Online command, 40
- Guard Tones command, 26

H

- handshake, 24
- hanging up, 16, 39
- Hardware Flow Control command, 37

I

- Immediate Line Probe command, 42
- inactivity timer, 49
- in-band escape sequence, 39
- indicators, 2
- Inquire Product Code command, 35
- installation, 8, 9
- Internet, 2

L

- LED indicators, 2
- line feed character, 47
- List Current Operating Parameters command, 35
- List Current S-Register Values command, 36
- List Online Diagnostics command, 36
- List Stored Telephone Numbers command, 20
- listing stored values, 20, 35, 36
- Load Default Configuration command, 21
- Login Password command, 40
- long space break, 28
- Long Space Disconnect command, 28
- Loopback Test Modes command, 43
- loopback testing, 54

M

- manual organization, 3
- Maximum Reliable Block Size command, 36
- memory
 - nonvolatile (NVRAM), 13, 19, 20, 21, 22, 52
 - read-only (ROM), 13, 20, 21, 22, 52
- MNP 3–5, 36
- MNP error correction enable, 31
- Modem Baud Rate command, 24, 34
- MultiModemManager software, 10, 54
- Multi-Tech BBS, 62

N

- noise, 27, 49
- non-error correction mode, 32, 38, 49
- Non-Error Correction Mode Flow Control command, 38
- Number Linking command, 20
- Number of XOFF Characters command, 38
- NVRAM (nonvolatile random access memory), 13, 19, 20, 21, 22, 52

O

On-Hook/Off-Hook command, 16
online connection commands, 24
online mode, 12, 40, 46, 54, 56
originate mode, 18, 34, 54
originating a call, 31, 34
out-of-band escape sequence, 39
out-of-service state (OOS), 2
out-of-service time, 26, 51

P

pacing, 36, 37, 38
 enable/disable, 38
 ENQ/ACK, 38
Pacing command, 38
parameters, 13, 20, 35
 default, 13, 29
parity, 37
PBX phone systems, 17, 49
PBX/CBX disconnect drop time, 30, 49
power, 2, 6
PS9600 power supplies, 9
pulse ratios, setting, 69
Pulse-Dial command, 17
Pulse-Dial Ratios command, 27

Q

Quiet Answer command, 19

R

Rate Renegotiation command, 36
Read Line Probe Data command, 41
reliable mode, 31, 36
Reliable Mode command, 31
remote configuration escape character, 48
Remote Digital Loopback command, 42
Repeat Last Command command, 35
Reset Modem command, 22
result codes, 13, 22, 23
 call progress selection, 23
 enable/disable, 22
 extended codes, 23
 Multi-Tech, 71
 set selection, 23
 standard, 72
 summary, 71
 verbose/terse selection, 23
Result Codes (Multi-Tech or Standard AT) command, 23
Result Codes (Verbose/Terse) command, 23
Result Codes and Call Progress Selection command, 17, 23

Result Codes Enable/Disable command, 22
Retrain command, 36
Retransmit Count command, 33
return character, 47
Return to Command Mode command, 18
Reverse Originate/Answer Mode command, 18
rings
 counting, 46
 number till answer, 46, 51
 square wave detection, 27
ROM (read-only memory), 13, 20, 21, 22, 52
RS-232C, 29, 30, 37
 controls, 29, 30
RTS signal, 30
 interaction with CTS signal, 30

S

safety, 8
self-test, 10
serial port baud rate, 34
service, 60
Set Pulse Dial Ratios command, 69
Setup Password command, 41
smart dialing, 16, 18, 23
specifications, 4
speed conversion, 33, 34
Square Wave Ring Detect command, 27
S-registers, 36, 52
 definition, 46
 reading, 52
 summary, 73
 S0, 46, 51
 S1, 46
 S2, 46
 S3, 47
 S4, 47
 S5, 13, 47
 S6, 16, 23, 47
 S7, 12, 19, 47, 51
 S8, 18, 48, 51
 S9, 48
 S10, 48
 S11, 48
 S13, 48
 S17, 49
 S24, 30, 49
 S25, 49
 S30, 49
 S32, 49
 S34, 50
 S36, 50
 S37, 50
 S43, 50

- S48, 50
- S94, 26, 51
- start bit, 37
- stop bit, 37
- Store Configuration command, 20, 21, 22, 52
- Store Phone Number command, 19, 20
- storing a configuration, 20, 51

T

- technical specifications, 4
- technical support, 61, 63
- terminal mode, 56
- testing, 42, 55, 56, 57
 - commands, 42
 - loopback tests, 42, 43, 54, 56
- tone detection, 25
- tone dialing, 69
- Tone-Dial command, 17
- tone-dialing, 48
- transmission speed, 33, 34
- Trellis-Coded Modulation command, 27

U

- upgrading the firmware, 64

V

- V.21, 24
- V.22, 24
- V.22bis, 24
- V.32, 25, 26
- V.32bis, 25, 26
- V.34, 25, 26
 - asymmetric bit rate, 28
 - connect speed, 50
 - echo canceler frequency offset compensation, 28
- V.42, 31, 32
- V.42 Error Correction at 300 bps command, 32
- V.42 Error Correction Mode command, 31

W

- Wait for New Dial Tone command, 17
- wait-for-carrier mode, 12
- warranty, 60
- World Wide Web, 64

X

- XON/XOFF, 37, 38
- XON/XOFF Flow Control command, 37
- XON/XOFF Pass-Through command, 37

