

***USER'S MANUAL***  
***Of***  
***Intel P43 Express and ICH10 Chipset***  
***Based***  
***M/B for LGA775 Quad Core Ready***  
***Intel Core Processor Family***

***MB Model: PXP43 (V2.0)***

***Manual: Rev: 1.0***  
***Release date: Sep , 2009***

**Trademark:**

\* Specifications and Information contained in this documentation are furnished for information use only, and are subject to change at any time without notice, and should not be construed as a commitment by manufacturer.

## Environmental Protection Announcement

Do not dispose this electronic device into the trash while discarding. To minimize pollution and ensure environment protection of mother earth, please recycle.



---

---

# TABLE OF CONTENT

---

---

USER'S NOTICE.....	iii
MANUAL REVISION INFORMATION .....	iii
COOLING SOLUTIONS.....	iii
<b>CHAPTER 1 INTRODUCTION OF P43 EXPRESS AND ICH10 MOTHERBOARDS</b>	
1-1 FEATURES OF MOTHERBOARD .....	1
1-1.1 SPECIAL FEATURES OF MOTHERBOARD.....	2
1-2 SPECIFICATION.....	3
1-3 PERFORMANCE LIST .....	4
1-4 LAYOUT DIAGRAM .....	5
<b>CHAPTER 2 HARDWARE INSTALLATION</b>	
2-1 HARDWARE INSTALLATION STEPS.....	7
2-2 CHECKING MOTHERBOARD'S JUMPER SETTING .....	7
2-3 INSTALL CPU.....	8
2-3-1 GLOSSARY.....	8
2-3-2 ABOUT INTEL LGA775 CPU .....	9
2-3-3 LGA 775 CPU INSTALLATION GUIDE .....	10
2-3-4 INTEL REFERENCE THERMAL SOLUTION ASSEMBLY .....	11
2-4 INSTALLING MEMORY .....	12
2-5 EXPANSION CARD .....	13
2-5-1 PROCEDURE FOR EXPANSION CARD INSTALLATION .....	13
2-5-2 ASSIGNING IRQ FOR EXPANSION CARD.....	13
2-5-3 PCI-EXPRESS SLOT.....	14
2-6 CONNECTORS, HEADERS .....	15
2-6-1 CONNECTORS.....	15
2-6-2 HEADERS .....	18
2-7 STARTING UP YOUR COMPUTER .....	21
<b>CHAPTER 3 INTRODUCING BIOS</b>	
3-1 ENTERING SETUP .....	22
3-2 GETTING HELP .....	22
3-3 THE MAIN MENU.....	23
3-4 STANDARD BIOS FEATURES.....	24
3-5 ADVANCED BIOS FEATURES.....	25
3-5-1 CPU FEATURES.....	26
3-6 ADVANCED CHIPSET FEATURES.....	26
3-7 INTEGRATED PERIPHERALS .....	26
3-7-1 ONBOARD SATA DEVICE .....	27
3-7-2 ONBOARD DEVICE FUNCTION.....	27
3-7-3 SUPER IO FUNCTION.....	28
3-8 POWER MANAGEMENT SETUP .....	28
3-9 PNP/PCI CONFIGURATION.....	29
3-10 PC HEALTH STATUS .....	29
3-10-1 SMART FAN CONFIGURATION .....	30
3-11 Miscellaneous Control.....	30
3-12 PASSWORD SETTING.....	31
3-13 LOAD STANDARD /OPTIMIZED DEFAULTS.....	32
3-14 SAVE CHNGES AND EXIT/DISCARD AND EXIT .....	32
<b>CHAPTER 4 DRIVER &amp; FREE PROGRAM INSTALLATION</b>	
4-1 INF: INSTALL INTEL INF CHIPSET SYSTEM DRIVER.....	35
4-2 LAN: GIGABIT ETHERNET LAN DRIVER .....	36
4-3 SOUND: INSTALL ALC883 HD AUDIO CODEC DRIVER .....	37
4-4 AHCI: INSTALL INTEL AHCI DRIVER.....	38
4-5 HOW TO UPDATE BIOS.....	39
4-6 G.P.I FUNCTION LED DISPLAY .....	40

---

---

## USER'S NOTICE

COPYRIGHT OF THIS MANUAL BELONGS TO THE MANUFACTURER. NO PART OF THIS MANUAL, INCLUDING THE PRODUCTS AND SOFTWARES DESCRIBED IN IT MAY BE REPRODUCED, TRANSMITTED OR TRANSLATED INTO ANY LANGUAGE IN ANY FORM OR BY ANY MEANS WITHOUT WRITTEN PERMISSION OF THE MANUFACTURER.

THIS MANUAL CONTAINS ALL INFORMATION REQUIRED FOR THE UTILIZATION OF P43 EXPRESS INTEL EDITION MOTHER-BOARDS TO MEET THE USER'S REQUIREMENTS. BUT IT WILL CHANGE, CORRECT AT ANY TIME WITHOUT NOTICE. MANUFACTURER PROVIDES THIS MANUAL "AS IS" WITHOUT WARRANTY OF ANY KIND, AND WILL NOT BE LIABLE FOR ANY INDIRECT, SPECIAL, INCIDENTAL OR CONSEQUENTIAL DAMAGES (INCLUDING DAMAGES FOR LOSS OF PROFIT, LOSS OF BUSINESS, LOSS OF USE OF DATA, INTERRUPTION OF BUSINESS AND THE LIKE).

PRODUCTS AND CORPORATE NAMES APPEARING IN THIS MANUAL MAY OR MAY NOT BE REGISTERED TRADEMARKS OR COPYRIGHTS OF THEIR RESPECTIVE COMPANIES, AND THEY ARE USED ONLY FOR IDENTIFICATION OR EXPLANATION AND TO THE OWNER'S BENEFIT, WITHOUT INTENT TO INFRINGE.

## Manual Revision Information

### Item Checklist

- P43+ICH10 Chipset based Motherboard
- User's Manual
- cable package
- CD for motherboard utilities
- I/O Back Panel Shield

## Intel Core Processor Family Cooling Solutions

As processor technology pushes to faster speeds and higher performance, thermal management becomes increasingly crucial while building computer systems. Maintaining the proper thermal environment is the key to reliable, long-term system operation. The overall goal in providing the proper thermal environment is keeping the processor below its specified maximum case temperature. Heat sinks induce improved processor heat dissipation through increased surface area and concentrated airflow from attached fans. In addition, interface materials allow effective transfers of heat from the processor to the heat sink. For optimum heat transfer, Intel recommends the use of thermal grease and mounting clips to attach the heat sink to the processor.

When selecting a thermal solution for your system, please refer to the website below for collection of heat sinks evaluated and recommended by Intel for use with Intel processors. Note, those heat sinks are recommended for maintaining the specified Maximum T case requirement. In addition, this collection is not intended to be a comprehensive listing of all heat sinks that support Intel processors.

---

---

# Chapter 1

## Introduction of Intel P43 Express and ICH10 chipset based Motherboards

### 1-1 Features of Motherboard

The P43 Express and ICH10 chipset motherboard series are based on Intel P43 Express chipset and ICH10 chipsets technology which supports the innovative 45nm and 65nm Quad-Core, Dual-Core Intel® Core 2 Quad, Core 2 Duo processors, Intel® Pentium Dual Core, Intel® Celeron Dual Core Conroe processors and Intel® Celeron 400 Conroe-L processors.

The P43 Express and ICH10 chipset Based motherboard series deliver the revolutionary levels of performance enabling vivid, high-definition experiences and multi-tasking responsiveness from state-of-the-art Intel dual-core and quad-core technologies and AMD CrossFireX Technology through the high bandwidth of dual channel DDR2 800 / 667MHz system memories which are expandable to 16GB and the next generation PCI Express interface for the latest graphics cards from both AMD and NVIDIA. The P43 Express and ICH10 chipset motherboard series are absolutely the ultimate solution for game enthusiasts and applications, and it also meets the demanding usage of computing of gaming, multimedia entertainment and business applications.

The INTEL P43 Express and ICH10 chipset motherboard series are embedded with ICH10 chipset of providing six serial ATA2 interface of 3.0 Gb / s data transfer rate for six serial ATA devices.

The P43 Express and ICH10 chipset based motherboard provides gigabit LAN function by using **Gigabit LAN chip** which supports 10M / 100M / 1Gbps data transfer rate. Embedded 8-channel ALC883 HD CODEC is fully compatible with Sound Blaster Pro® standards that offer you with the home cinema quality and absolutely software compatibility.

The P43 Express chipset Based motherboard series offer two PCI-Express x16 graphics slots that support CrossFireX mode. **One PCI-Express2.0 x16@16lane graphics slot offers 8 Gbyte/sec data transfer rate at each relative direction which get 7 times of bandwidth more than AGP8X and up to 16Gbyte/sec concurrent bandwidth at full speed, the other PCI-Express 1.0a x16@4lane graphics slots deliver up to 2Gbyte/sec data transfer rate.** These two graphics slots are fully compatible with the latest AMD CrossFireX Technology and avoid the possible CrossFireX installation error. Two PCI Express1.0a x1 I/O slots offer 512Mbyte/sec concurrently, over 3.5 times more bandwidth than PCI at 133Mbyte/sec, tackling the most demanding multimedia tasks nowadays. Two 32-bit PCI slots guarantee the rich connectivity for the I/O of peripherals.

Embedded USB controllers as well as capability of expanding to 10 of USB2.0 functional ports delivering 480Mb/s bandwidth of rich connectivity, these motherboards meet the future USB demands which are also equipped with hardware monitor function on system to monitor and protect your system and maintain your non-stop business computing.

Some special features---**CPU Thermal Throttling/ CPU Smart Fan/ CPU Vcore X-shift/ DIY Clear/OC-CON /G.P.I. Function/WI-FI Technology** in this motherboard are designed for power user to use the over-clocking function in more flexible ways. But please be caution

---

---

that the over-clocking may cause the failure in system reliability. This motherboard provides the guaranteed performance and meets the demands of the next generation computing. But if you insist to gain more system performance with variety possibilities of the components you choose, please be careful and make sure to read the detailed descriptions of these value added product features, please get them in the coming section.

## **1-1.1 Special Features of motherboard**

### **CPU Thermal Throttling Technology---** (The CPU Overheat Protection Technology)

To prevent the increasing heat from damage of CPU or accidental shutdown while at high workload, the CPU Thermal Throttling Technology will force CPU to enter partially idle mode from 87.5% to 12.5% according to preset CPU operating temperature in BIOS (from 40 °C to 90°C). When the system senses the CPU operating temperature reaching the preset value, the CPU operating bandwidth will be decreased to the preset idle percentage to cool down the processor. When at throttling mode the beeper sound can be optionally selected to indicate it is working.

### **CPU Smart Fan---** The Noise Management System

It's never been a good idea to gain the performance of your system by sacrificing its acoustics. CPU Smart Fan Noise Management System is the answer to control the noise level needed for now-a-day's high performance computing system. The system will automatically increase the fan speed when CPU operating loading is high, after the CPU is in normal operating condition, the system will low down the fan speed for the silent operating environment. The system can provide the much longer life cycle for both CPU and the system fans for game use and business requirements.

### **CPU Vcore X-Shift---** Shift to Higher Performance

The CPU voltage can be adjusted up by 64 stages for the precisely over-clocking of extra demanding computing performance.

### **DIY Clear**

The CMOS Button is to facilitate the clear COMS process for power user overclocking function. The user can easily clear or restore COMS settings by pressing down the button, without taking trouble to remove the case and locate the jumper for clear CMOS.

### **OC-CON---**High-polymer Solid Electrolysis Aluminum Capacitors (Optional, for HI04 series only)

The working temperature is from 55 degrees Centigrade below zero to 125 degrees Centigrade, OC-CON capacitors possess superior physical characteristics that can be while reducing the working temperature between 20 degrees Centigrade each time, intact extension 10 times of effective product operation lives, at not rising degrees Centigrade of working temperatures each time a relative one, life of product decline 10% only too.

### **G.P.I Function---**(Green power indicator function)

G.P.I is a technology with remarkable power saving function: when you are using a computer with G.P.I mode turned on, you save averagely 10.5w in power consumption in the whole process than normal computer without G.P.I technology.

### **WI-FI Technology**

WIFI--Full name is wireless Fidelity. It has been used in notebook, mobile phone, PDA, digital cameras and Mobile Terminals widely. With WIFI. We do not need to worry about the speed and high spending when we are dialing long-distance calls, browsing web pages, receiving and sending E-mails, loading music, delivering digital photos.

## 1-2 Specification

Spec	Description
<b>Design</b>	<ul style="list-style-type: none"> <li>● ATX form factor 4 layers PCB size: 30.5x22.0cm</li> </ul>
<b>Chipset</b>	<ul style="list-style-type: none"> <li>● Intel P43 Express Chipset</li> <li>● Intel ICH10 chipset</li> </ul>
<b>CPU Socket LGA775</b>	<ul style="list-style-type: none"> <li>● Support 45nm and 65nm Quad-Core, Dual-Core Intel® Core 2 Quad, Core 2 Duo processors, Intel® Pentium Dual Core, Intel® Celeron Dual Core Conroe processors and Intel® Celeron 400 Conroe-L processors 775-Land LGA Package utilizes Flip-Chip Land Grid Array (FCLGA) package processor</li> <li>● Support FSB Frequency 800/1066/1333MHz</li> </ul>
<b>Memory Socket</b>	<ul style="list-style-type: none"> <li>● DDR2 Module socket x 4</li> <li>● Support 4 pcs DDR2 667 /DDR2 800MHz DDR2 modules expandable to 16GB</li> <li>● Support Dual channel function</li> </ul>
<b>Expansion Slot</b>	<ul style="list-style-type: none"> <li>● PCI-Express x16 slot 2pcs</li> <li>● PCI-Express x1 slot 2pcs</li> <li>● 32-bit PCI slot x 2pcs</li> </ul>
<b>Integrated Serial ATA2</b>	<ul style="list-style-type: none"> <li>● The Intel ICH10 supports six Serial ATA ports provide 3.0 Gb/sec data transfer rate.</li> </ul>
<b>Gigabit LAN</b>	<ul style="list-style-type: none"> <li>● Integrated Gigabit LAN chip.</li> <li>● Supports Fast Ethernet provide 10Mb/100Mb/ 1Gb /s data transfer rate.</li> </ul>
<b>8CH-Audio</b>	<ul style="list-style-type: none"> <li>● Realtek ALC883 8-channel HD Audio Codec integrated</li> <li>● Support 8-channel 3D surround &amp; Positioning Audio</li> <li>● Audio driver and utility included</li> </ul>
<b>BIOS</b>	<ul style="list-style-type: none"> <li>● 8MB Flash ROM</li> </ul>
<b>Multi I/O</b>	<ul style="list-style-type: none"> <li>● PS/2 keyboard and PS/2 mouse connectors</li> <li>● Floppy disk drive connector x1</li> <li>● SATA Connector x6</li> <li>● SPDIF_OUT connector x1</li> <li>● HDMI_SPDIF header x1/IR header</li> <li>● USB2.0 port x 4 and headers x3</li> <li>● RJ-45 LAN connector x1</li> <li>● Serial port connector x1</li> <li>● Parallel header x1</li> <li>● WI-FI header x1</li> <li>● Audio connectorx1 (8-CH Audio)</li> </ul>

---

---

## 1-3 Performance List

The following performance data list is the testing result of some popular benchmark testing programs. These data are just referred by users, and there is no responsibility for different testing data values gotten by users (the different Hardware & Software configuration will result in different benchmark testing results.)

### System Configuration

CPU Type: Intel Core 2 Duo E6550; Intel Core 2 Duo E8400

Memory Type: Crucial DDR2 1066 2GB(1Gx2)

Display Card: Geforce 8800GTX 768MB

Hard Disk: WD WD5000AAKS SATA2 500GB

OS: Microsoft Windows XP Professional 5.01.2600 Service Pack 2

BIOS Rev.: PXP43

<b>Performance</b>	<b>Intel Core 2 Duo E6550</b>	<b>Intel Core 2 Duo E8400</b>
<b>3DMark 06</b>		
Default	10474	12031
SM 2.0	4872	5401
SM 3.0 /HDR	5220	5570
CPU	2135	2838
CPU Test 1	0.673	0.895
CPU Test 2	1.084	1.439
<b>CINEBENCH R10</b>		
Single CPU	2395	3293
Multiple CPU	4624	6362
OpenGL	5672	6500
<b>Super PI / Mod1.5</b>		
1M Test	21.656	15.469
4M Test	154.672	126.984
<b>Sandra 2005 /CPU</b>		
ALU	28155	36367
FPU	7094	9857
SSE2	10468	15131
Integer	61403	78647
Floating	69518	89813
<b>EVEREST 2006</b>		
Memory Read	7658	7107
Memory Write	6040	7101
Memory Copy	6816	7002
Memory Latency	66.1	72.7



# Layout Diagram

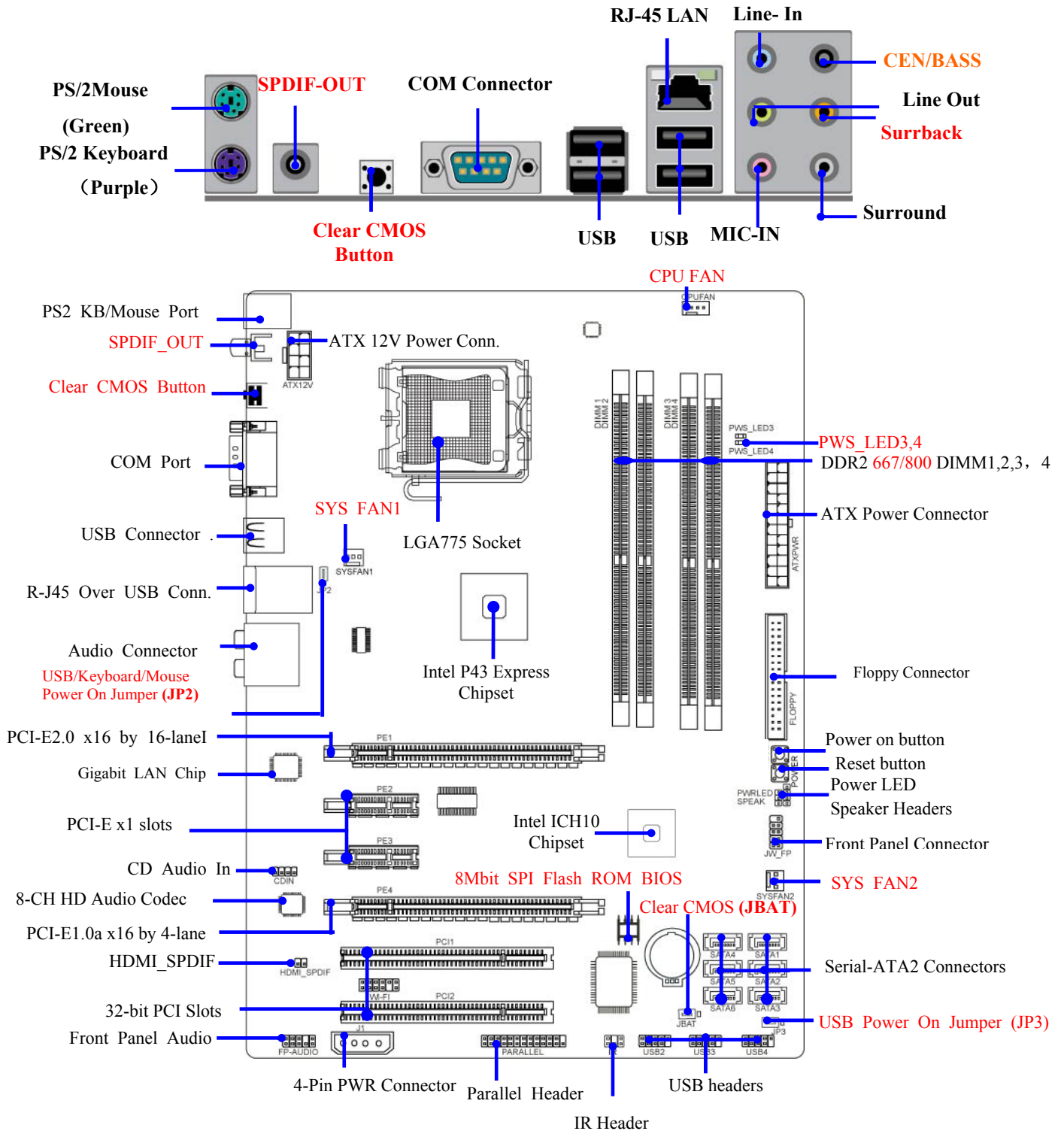

### Jumpers

Jumper	Name	Description	Page
JBAT	CMOS RAM Clear	3-pin Block	P.7
JP2	Keyboard and USB Power On Enabled/Disabled	3-pin Block	P.8
JP3	USB Power On Enabled/Disabled	3-pin Block	P.8

### Connectors

Connector	Name	Description	Page
ATXPWR	ATX Power Connector	24-pin Block	P.22
ATX12V	ATX 12V Power Connector	8-pin Block	P.23
J1	CrossFire Power Connector	4-pin Block	P.23
KB	PS/2 Mouse & PS/2 Keyboard Connector	6-pin Female	P.23
USB from USB1, UL1	USB 2.0 Port Connector	4-pin Connector	P.23
RJ45 LAN from UL1	RJ45 LAN Port Over USB Connector.	8-pin Connector	P.23
AUDIO	8-CH Audio Connector	6 phone jack Connector	P.23
FLOPPY	Floppy Driver Connector	34-pin Block	P.24
SATA1~SATA6	Serial ATA2 Connector	7-pin Connector	P.24
COM1	Serial Port Connector	9-pin Connector	P.24
SPDIF_Out 2	Optical SPDIF Out Connector	1 phone connector	P.24

### Headers

Header	Name	Description	Page
FP_AUDIO	SPEAKER, MIC header	9-pin Block	P.25
USB2, USB3/USB4	Front Panel USB Port Headers	9-pin Block	P.25
SPEAK	PC Speaker header	4-pin Block	P.25
PWR_LED	Power LED header	3-pin Block	P.25
JW_FP(PW_LED/Reset/ HD_LED/PWR_BTN)	Front Panel Header (including Power LED/ IDE activity LED/Reset switch / Power On Button led)	9-pin Block	P.25
CPUFAN	CPUFAN Headers	4-pin Block	P.26
SYSFAN1, SYSFAN32	System FAN Headers	3-pin Block	P.26
CDIN	CD Audio-In Header	4-pin Block	P.26
IR	IR Header	5-pin Block	P.26
Parallel	Parallel Header	25-pin Block	P.27
HDMI-SPDIF	SPDIF-Out header	2-pin Block	P.27
WI-FI	Wi-Fi Header	11-pin Block	P.27

### Expansion Sockets

Socket/Slot	Name	Description	Page
LGA 775 Socket	CPU Socket	LGA 775 CPU Socket	P.9
DIMM 1, 2, 3, 4	DDR2 Module Sockets	240-pin DDR2 Module Sockets	P.19
PCI1~PCI2	PCI Slots	32-bit PCI Local Bus Expansion slots	P.21
PE1	PCI-Express2.0 x16 Slot	PCI-Express2.0 x16 Expansion Slot	P.21
PE2, PE3	PCI-Express1.0a x1 Slots	PCI-Express1.0a x1 Expansion Slots	P.21
PE4	PCI-Express1.0a x16 Slot	PCI-Express1.0a x16 Expansion Slot	P.21

---

---

# Chapter 2

## Hardware Installation

**WARNING!** Turn off your power when adding or removing expansion cards or other system components. Failure to do so may cause severe damage to both your motherboard and expansion cards.

### 2-1 Hardware installation Steps

Before using your computer, you had better complete the following steps:

1. Check motherboard jumper setting
2. Install CPU and Fan
3. Install System Memory (DIMM)
4. Install Expansion cards
5. Connect IDE Front Panel /Back Panel cable
6. Connect ATX Power cable
7. Power-On and Load Standard Default
8. Reboot
9. Install Operating System
10. Install Driver and Utility

### 2-2 Checking Motherboard's Jumper Setting

#### (1) CMOS RAM Clear (3-pin): JBAT

A battery must be used to retain the motherboard configuration in CMOS RAM short 1-2 pins of JBAT to store the CMOS data.

To clear the CMOS, follow the procedure below:

1. Turn off the system and unplug the AC power
2. Remove ATX power cable from ATX power connector
3. Locate JBAT and short pins 2-3 for a few seconds
4. Return JBAT to its normal setting by shorting pins 1-2
5. Connect ATX power cable back to ATX power connector

**Note: When should clear CMOS**

1. **Troubleshooting**
2. **Forget password**
3. **After over clocking system boot fail**

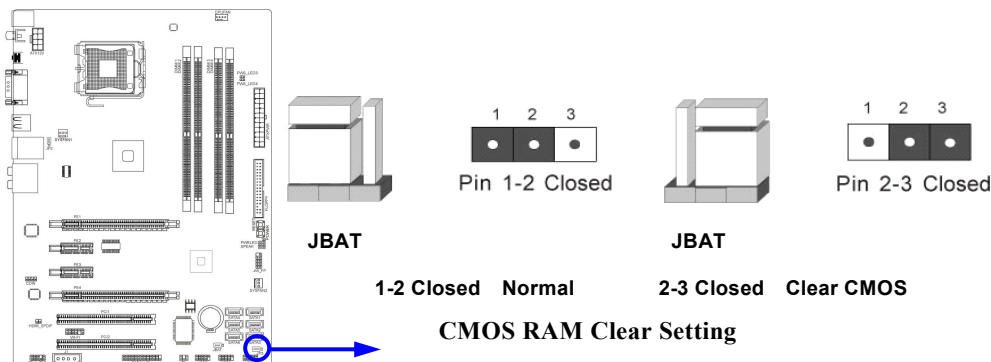

---

---

## (2) Keyboard & Mouse & USB Power On function Enabled/Disabled: JP2

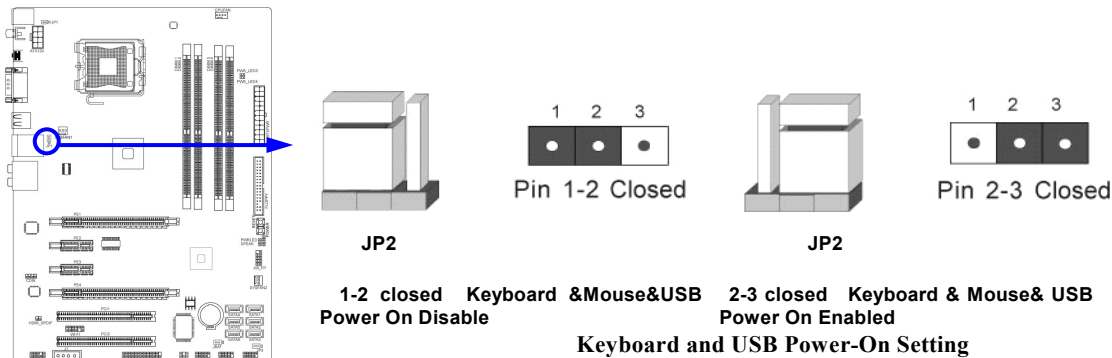

## (3) USB Power On function Enabled/Disabled: JP3

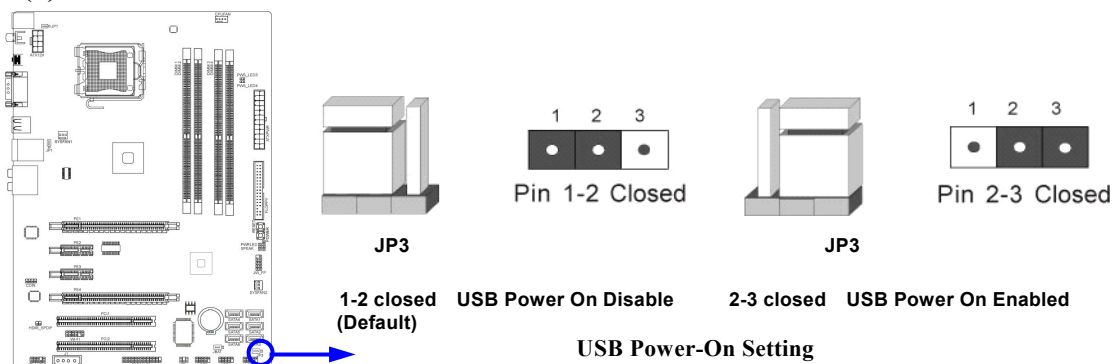

## 2-3 Installing CPU

### 2-3-1 Glossary

**Chipset (or core logic)** - two or more integrated circuits which control the interfaces between the system processor, RAM, I/O devices, and adapter cards.

**Processor slot/socket** - the slot or socket used to mount the system processor on the motherboard.

**Slot (PCI-E, PCI, RAM)** - the slots used to mount adapter cards and system RAM.

**PCI - Peripheral Component Interconnect** - a high speed interface for video cards, sound cards, network interface cards, and modems; runs at 33MHz.

**PCI Express 2.0** - Peripheral Component Interconnect Express 2.0, developed in 2003, the speed of each line doubled from the previous PCI-E of 2.5Gbps to 5 Gbps.

**Serial Port** - a low speed interface typically used for mouse and external modems.

**Parallel Port** - a low speed interface typically used for printers.

**PS/2** - a low speed interface used for mouse and keyboards.

**USB - Universal Serial Bus** - a medium speed interface typically used for mouse, keyboards, scanners, and some digital cameras.

**Sound (interface)** - the interface between the sound card or integrated sound connectors and speakers, MIC, game controllers, and MIDI sound devices.

**LAN (interface) - Local Area Network** - the interface to your local area network.

**BIOS (Basic Input/Output System)** - the program logic used to boot up a computer and establish the relationship between the various components.

**Driver** - software, which defines the characteristics of a device for use by another device or

---

---

other software.

**Processor** - the "central processing unit" (CPU); the principal integrated circuit used for doing the "computing" in "personal computer"

**Front Side Bus Frequency** - the working frequency of the motherboard, which is generated by the clock generator for CPU, DRAM and PCI BUS.

**CPU L2 Cache** - the flash memory inside the CPU, normal it depend on CPU type.

## 2-3-2 About Intel LGA775 CPU

This motherboard provides a 775-pin DIP, LGA775 Land Grid Array socket, referred to as the LGA775 socket supports Intel Pentium 4 processor in the 775 Pin package utilizes Flip-Chip Land Grid Array (FC-LGA) package technology.

The CPU that comes with the motherboard should have a cooling FAN attached to prevent overheating. If this is not the case, then purchase a correct cooling FAN before you turn on your system.

**NOTED!** Be sure that there is sufficient air circulation across the processor's heat sink and CPU cooling FAN is working correctly, otherwise it may cause the processor and motherboard overheat and damage, you may install an auxiliary cooling FAN, if necessary.

To install a CPU, first turn off your system and remove its cover. Locate the LGA775 socket and open it by first pulling the level sideways away from the socket then upward to a 90-degree angle. Insert the CPU with the correct orientation as shown below. The notched corner should point toward the end of the level. Because the CPU has a corner pin for two of the four corners, the CPU will only fit in the orientation as shown.

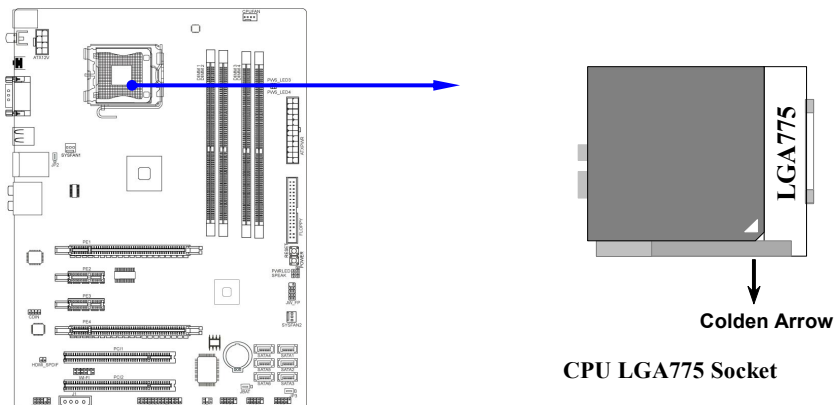

When you install the CPU into the LGA775 socket, there's no force required CPU insertion; then press the level to locate position slightly without any extra force.

## 2-3-3 LGA 775 CPU Installation Guide



1. Please make sure that CPU socket is facing towards you and the level is on you left hand side.

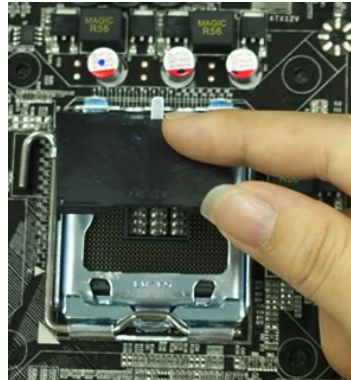

2. Remove the plastic protective cap from the socket. ( Put it to the original place if CPU is not installed . Do not touch the metal contact point of the CPU socket).

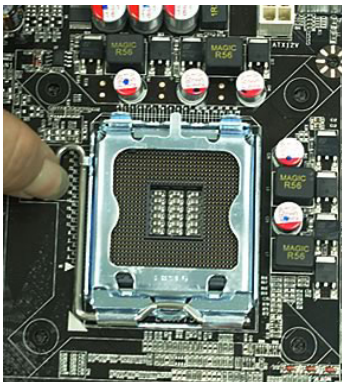

3. Press down the level and move it to the left side to make sure it is freed from the hook.

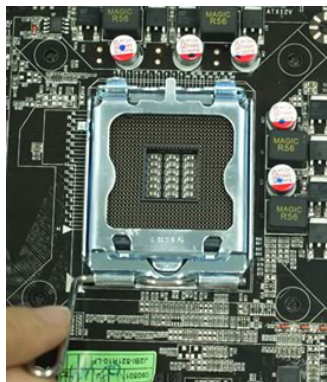

4. To open the level upwards about 135 degree.

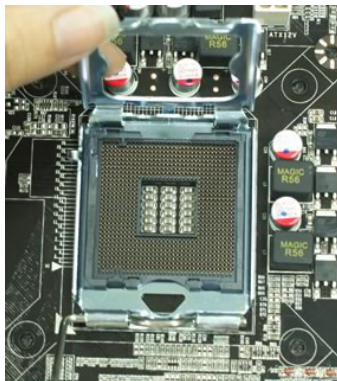

5. Pick up the lode plate upwards about 100 degree to make sure it is moved upwards.

Pin-1  
Indicator

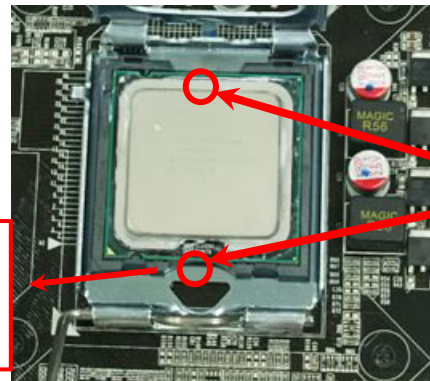

Alignment  
Keys

6. Make sure that golden finger is on the left-down side as shown and match the two alignment keys on the CPU with two points of the socket. CPU can only be correctly installed with this direction. Incorrect installation might cause damage to CPU .

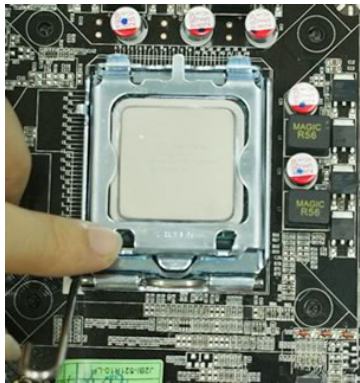

7. Put down the load plate.



8. Press down the load level and move it rightwards make sure it is locked under the notch.

## 2-3-4 Intel Reference Thermal Solution Assembly

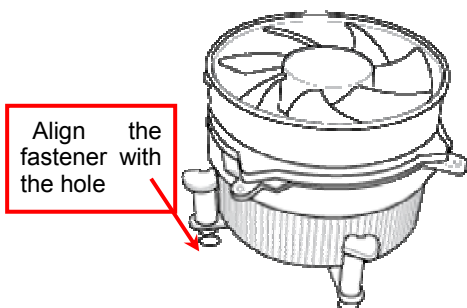

1. Put the heat sink vertically above the CP-installed socket and make sure to align the four fasteners with four holes around the socket.

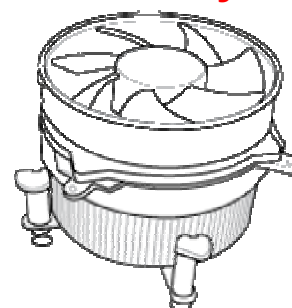

2. Revolve the four fasteners in the counter-clockwise direction.

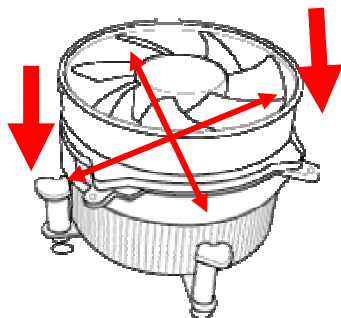

3. Press down two fasteners down in the oblique crossing direction as shown above.

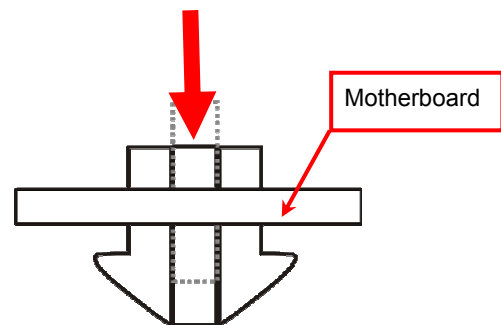

4. Turn over the motherboard carefully to make sure the fastener insert in the right direction.

### Notice:

- ▶ Please apply thermal interface material to the CPU HIS surface;
- ▶ The heat sink and installation steps are for reference use only; Installation steps might differ depending on different heat sink models;
- ▶ Please use Intel original heat sink for better heat dissipation or other heat sinks that has pass Intel certification
- ▶ Different electric fans might require different installation operation so please read the instructions of the producers at first as reference to installation.

## 2-4 Installing Memory

This motherboard provides four 240-pin DDR2 DUAL INLINE MEMORY MODULES (DIMM) socket for DDR2 memory expansion available from minimum memory volume of 128MB to maximum memory volume of 16GB DDR SDRAM .

### Valid Memory Configurations for DDR2

Bank	240-Pin DIMM	PCS	Total Memory
Bank 0, 1 (DIMM1)	DDR2 667 /DDR2 800	X1	128MB~4GB
Bank 2, 3 (DIMM2)	DDR2 667 /DDR2 800	X1	128MB~4GB
Bank 4, 5 (DIMM3)	DDR2 667 /DDR2 800	X1	128MB~4GB
Bank 6,7 (DIMM4)	DDR2 667 /DDR2 800	X1	128MB~4GB
Total	System Memory (Max. 16 GB)	4	128MB~16GB

### Recommend DIMM Module Combination

1. **One DIMM Module ----Plug in DIMM1**
2. **Two DIMM Modules---Plug in two slots of the same color for Dual channel function.**
3. **Four DIMM Modules---Plug in DIMM1/DIMM2/DIMM3/ DIMM4 .**

### For Dual channel Limited!

1. Dual channel function only supports when 2 DIMM Modules plug in two slots of the same color, or 4 DIMM Modules plug in DIMM1/DIMM2/DIMM3/ DIMM4.
2. DIMM Modules must be the same type, same size, and same frequency for dual channel function.

Install DDR SDRAM modules to your motherboard is not difficult, you can refer to figure below to see how to install a 240-Pin DDR2 667/DDR2 800.

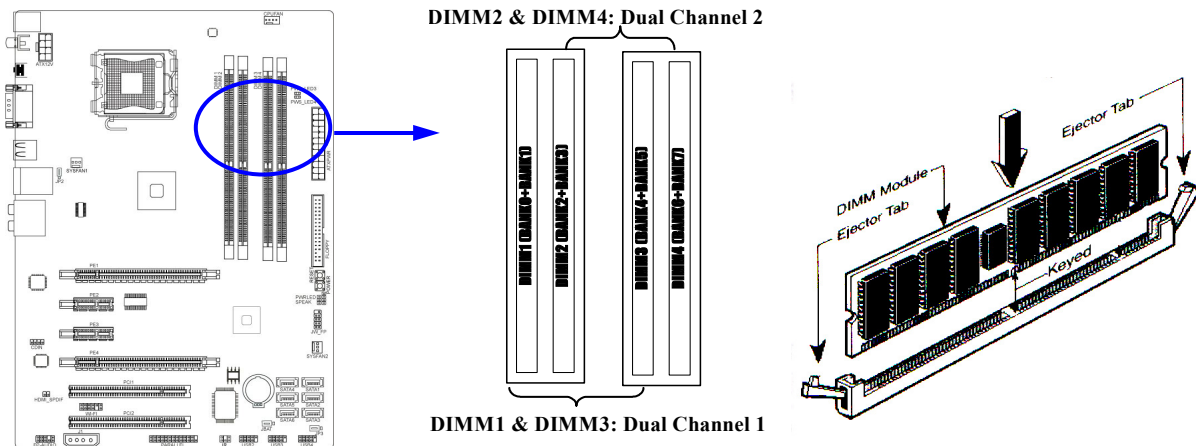

**NOTED!** When you install DIMM module fully into the DIMM socket, the eject tab should be locked firmly and fit into its indentation on both sides.

**WARNING!** This motherboard only supports DDR2 667/800 or higher frequency-compliant DDR2 Modules.



---

---

## 2-5 Expansion Cards

### 2-5-1 Procedure For Expansion Card Installation

1. Read the documentation for your expansion card and make any necessary hardware or software setting for your expansion card such as jumpers.
2. Remove your computer's cover and the bracket plate on the slot you intend to use.
3. Align the card's connectors and press firmly.
4. Secure the card on the slot with the screen you remove above.
5. Replace the computer system's cover.
6. Set up the BIOS if necessary.
7. Install the necessary software driver for your expansion card.

### 2-5-2 Assigning IRQs for Expansion Card

Some expansion cards need to set up the IRQ to operate. An IRQ must be assigned exclusively to single interface use only. There are 16 IRQs available but most of them are already being used.

#### Standard Interrupt Assignments

IRQ	Priority	Standard function
0	N/A	System Timer
1	N/A	Keyboard Controller
2	N/A	Programmable Interrupt
3 *	8	Communications Port (COM2)
4 *	9	Communications Port (COM1)
5 *	6	Sound Card (sometimes LPT2)
6 *	11	Floppy Disk Controller
7 *	7	Printer Port (LPT1)
8	N/A	System CMOS/Real Time Clock
9 *	10	ACPI Mode when enabled
10 *	3	IRQ Holder for PCI Steering
11 *	2	IRQ Holder for PCI Steering
12 *	4	PS/2 Compatible Mouse Port
13	N/A	Numeric Data Processor
14 *	5	Primary IDE Channel
15 *	1	Secondary IDE Channel

\* These IRQs are usually available for ISA or PCI devices.

---

---

### 2-5-3 PCI Express Slot

The P43 Express chipset is based motherboard series offer two PCI-Express x16 graphics slots that support CrossFireX Mode. One PCI-Express2.0 x16@16lane graphics slot offers 8 Gbyte/sec data transfer rate at each relative direction which get 7 times of bandwidth more than AGP8X and up to 16Gbyte/sec concurrent bandwidth at full speed, the other PCI-Express 1.0a x16@4lane graphics slots deliver up to 2Gbyte/sec data transfer rate. These two graphics slots are fully compatible with the latest AMD CrossFireX Technology and avoid the possible CrossFireX installation error. Two PCI Express1.0a x1 I/O slots offer 512Mbyte/sec concurrently, over 3.5 times more bandwidth than PCI at 133Mbyte/sec, tackling the most demanding multimedia tasks nowadays. Two 32-bit PCI slots guarantee the rich connectivity for the I/O of peripherals.

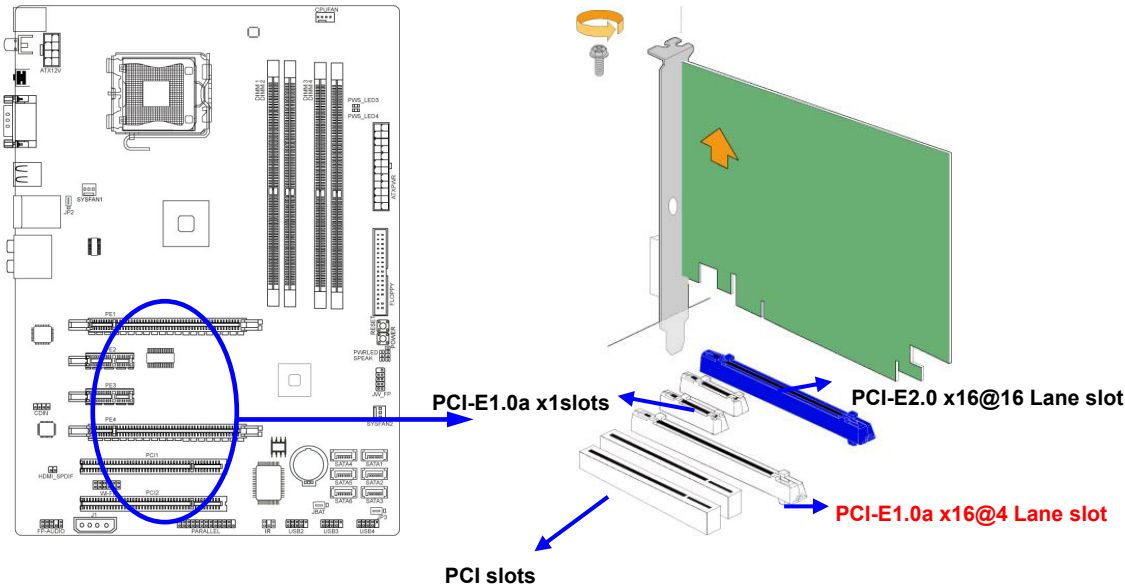

## 2-6 Connectors, Headers

### 2-6-1 Connectors

#### (1) Power Connector (24-pin block): ATXPWR

ATX Power Supply connector: This is a new defined 24-pins connector that usually comes with ATX case. The ATX Power Supply allows using soft power on momentary switch that connect from the front panel switch to 2-pins Power On jumper pole on the motherboard. When the power switch on the back of the ATX power supply turned on, the full power will not come into the system board until the front panel switch is momentarily pressed. Press this switch again will turn off the power to the system board.

- \*\* We recommend that you use an ATX 12V Specification 2.0-compliant power supply unit (PSU) with a minimum of 350W power rating. This type has 24-pin and 4-pin power plugs.
- \*\* If you intend to use a PSU with 20-pin and 4-pin power plugs, make sure that the 20-pin power plug can provide at least 15A on +12V and the power supply unit has a minimum power rating of 350W. The system may become unstable or may not boot up if the power is inadequate.

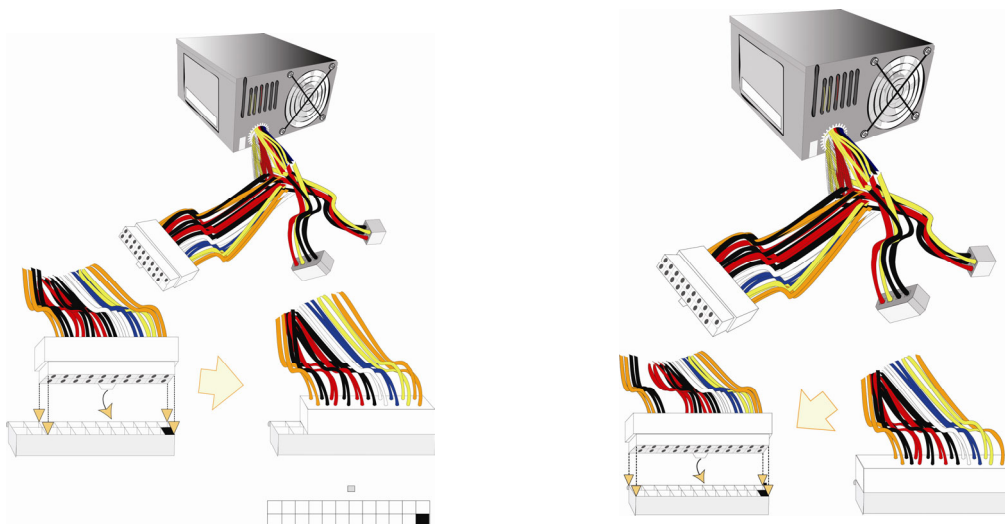
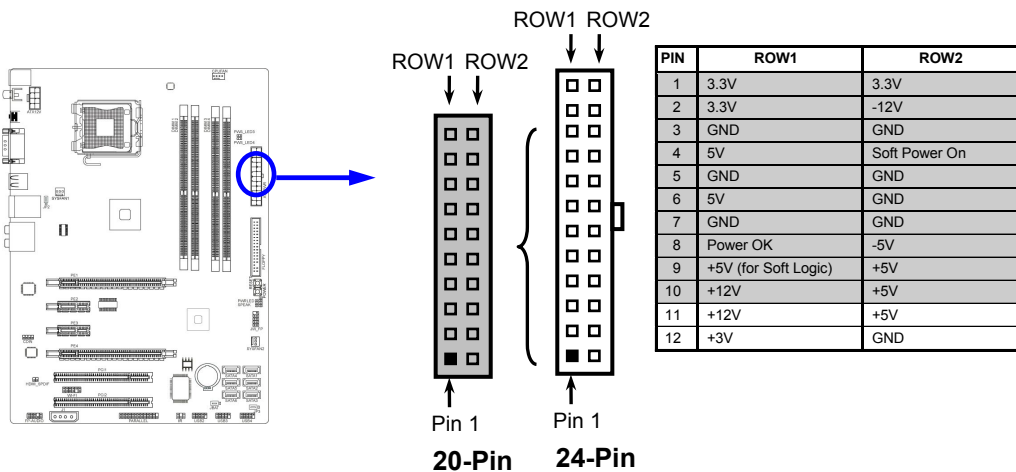

---

---

(2) **ATX 12V Power Connector (8-pin block) : ATX12V**

This is a new defined 8-pin connector that usually comes with ATX Power Supply. The ATX Power Supply which fully supports LGA775 processor must including this connector for support extra 12V voltage to maintain system power consumption. Without this connector might cause system unstable because the power supply can not provide sufficient current for system.

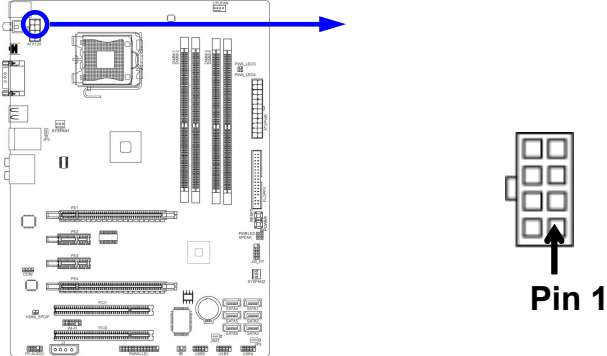

(3) **J1 Power Connector: Large 4-Pin Power Connector**

The connectors are 4-pin connector that supports extra 12V / 5V power to your system.

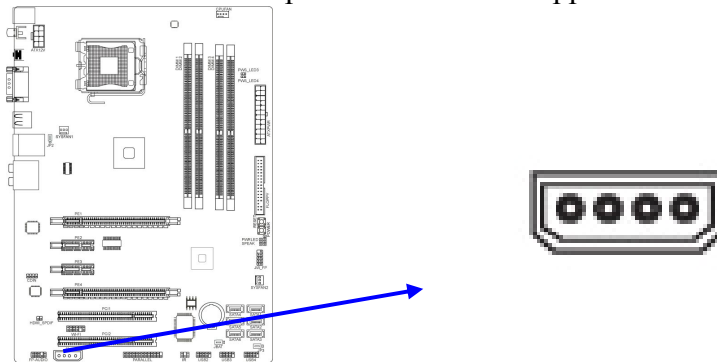

(4) **PS/2 Mouse & PS/2 Keyboard Connector: KB**

The connectors are for PS/2 keyboard and PS/2 Mouse input devices.

(5) **USB Port connector: USB connector from USB1, UL1**

The connectors are 4-pin connectors that connect USB devices with the 400Mbit / sec data transfer rate to the system board.

(6) **LAN Port connector: R-J45 connector from UL1**

This connector is standard RJ45 over USB connectors for Network connection. The connector supports 10MB/100MB/1G B/s data transfer rate.

(7) **Audio Line-In, Lin-Out, MIC, RS-Out, CS-Out, SS-Out connector : AUDIO**

These Connectors are 6 Phone-Jack for LINE-OUT, LINE-IN, MIC, RS-Out, CS-Out , SS-Out audio connections.

<b>Line-in : (BLUE)</b>	Audio input to sound chip
<b>Line-out : (GREEN)</b>	Audio output to speaker
<b>MIC : (PINK)</b>	Microphone Connector
<b>RS-OUT : (BLACK)</b>	Rear-Surround audio output
<b>CS-OUT : (ORANGE)</b>	Center/ Subwoofer audio output
<b>SS-OUT: (GRAY)</b>	Side-Surround audio output

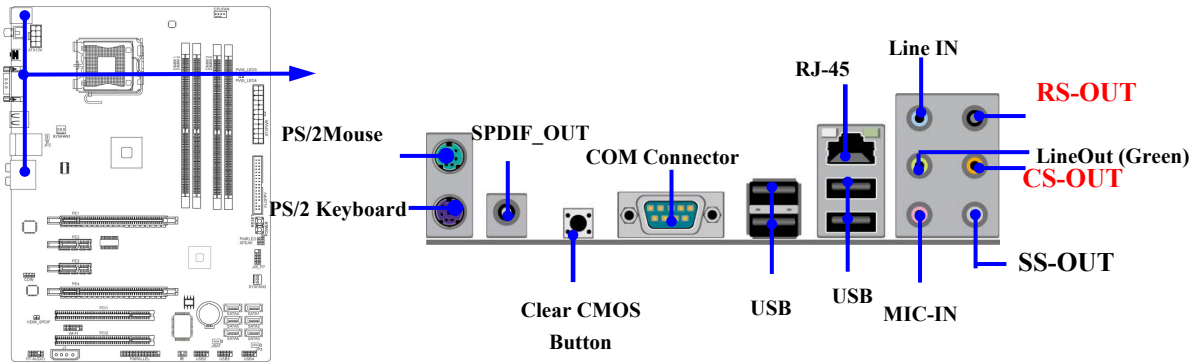

**(8) Floppy drive Connector (34-pin block): FLOPPY**

This connector supports the provided floppy drive ribbon cable. After connecting the single plug end to motherboard, connect the two plugs at other end to the floppy drives.

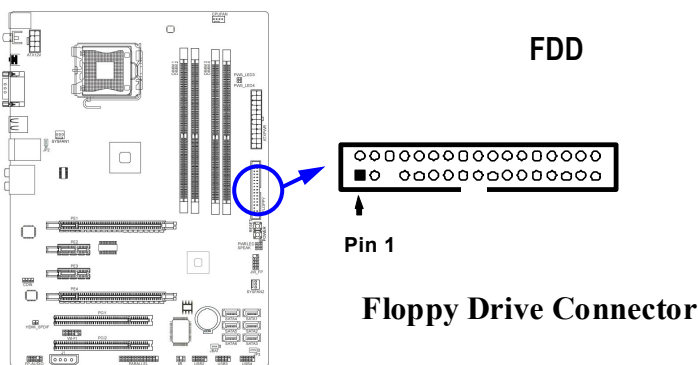

**(9) Serial-ATA2 Port connectors: SATA1~SATA6**

These connectors support the provided Serial ATA and Serial ATA2 IDE hard disk cable to connect the motherboard and serial ATA2 hard disk drives.

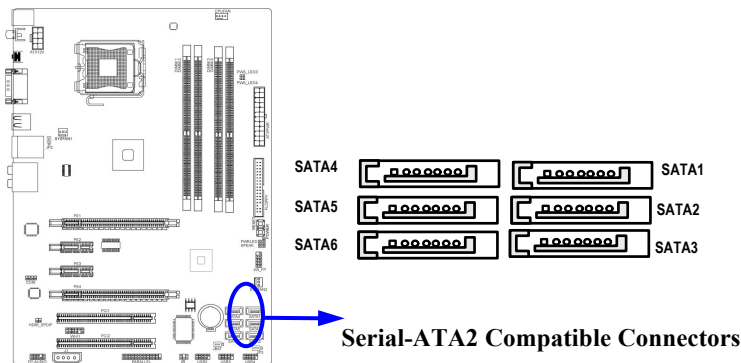

**(10) Serial port connector: COM1**

COM1 is a 9-pin RS232 serial port connector.

**(11) SPDIF\_OUT and SPDIF\_In connectors: SPDIF\_OUT**

The SPDIF output is capable of providing digital audio to external speakers or compressed AC3 data to an external Dolby digital decoder. Use this feature only when your stereo system has digital input function.

---

---

## 2-6-2 Headers

### (1) Line-Out/MIC Header for Front Panel (9-pin): FP\_AUDIO

These headers connect to Front Panel Line-out, MIC connector with cable.

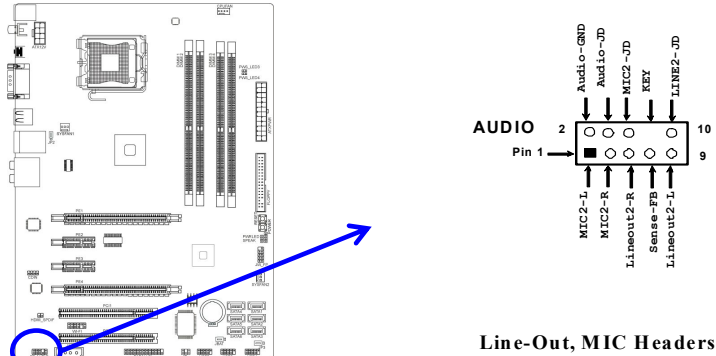

### (2) USB Port Headers (9-pin): USB2/ USB3/USB4

These headers are used for connecting the additional USB port plugs. By attaching an option USB cable, your can be provided with two additional USB plugs affixed to the back panel.

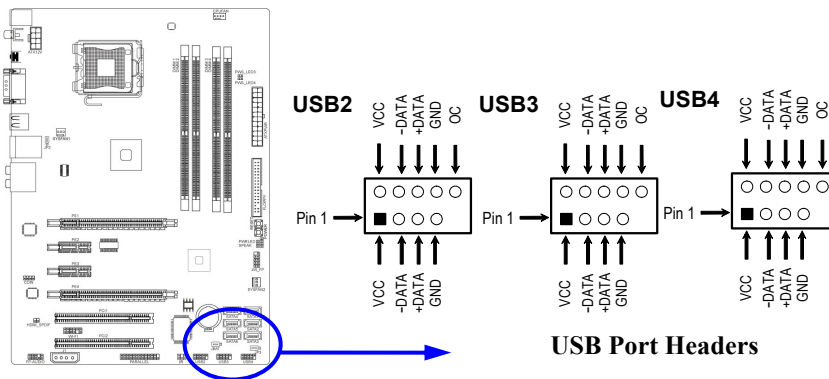

### (3) Speaker connector: SPEAK

This 4-pin connector connects to the case-mounted speaker. See the figure below.

### (4) Power LED: PWR LED

The Power LED is light on while the system power is on. Connect the Power LED from the system case to this pin.

### (5) IDE Activity LED: HD LED

This connector connects to the hard disk activity indicator light on the case.

### (6) Reset switch lead: RESET

This 2-pin connector connects to the case-mounted reset switch for rebooting your computer without having to turn off your power switch. This is a preferred method of rebooting in order to prolong the life of the system's power supply. See the figure below.

### (7) Power switch: PWR BTN

This 2-pin connector connects to the case-mounted power switch to power ON/OFF the system.

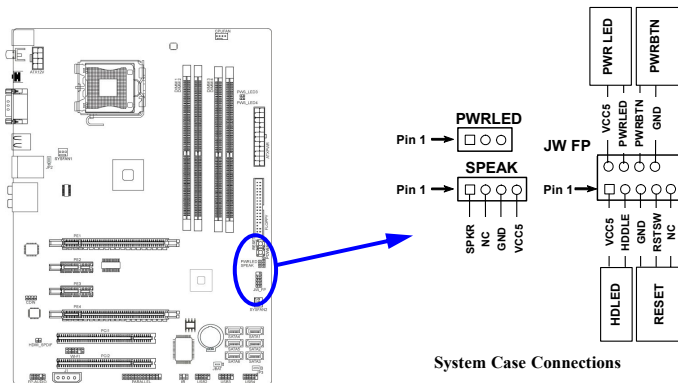

**(8) FAN Headers: SYSFAN1, SYSFAN2 (3-pin), CPUFAN (4-pin)**

These connectors support cooling fans of 350mA (4.2 Watts) or less, depending on the fan manufacturer, the wire and plug may be different. The red wire should be positive, while the black should be ground. Please connect the fan's plug to the board taking into consideration the polarity of connector.

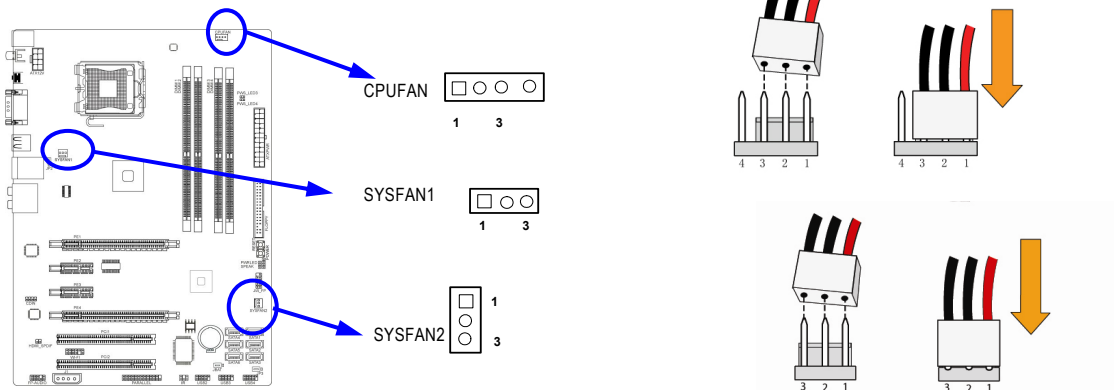

**(9) CD Audio-In Headers (4-pin) : CDIN**

CDIN are the connectors for CD-Audio Input signal. Please connect it to CD-ROM CD-Audio output connector.

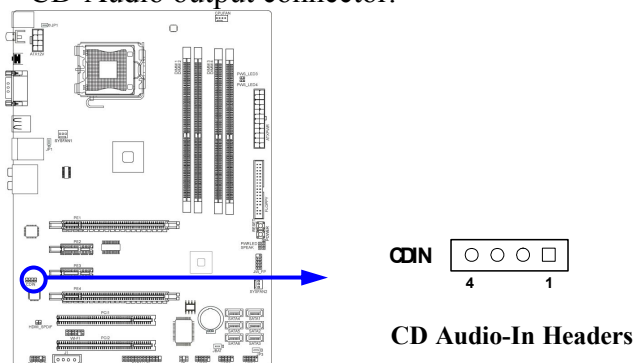

**(10) IR infrared module Headers (5-pin): IR**

This connector supports the optional wireless transmitting and receiving infrared module. You must configure the setting through the BIOS setup to use the IR function.

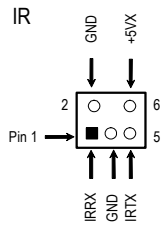
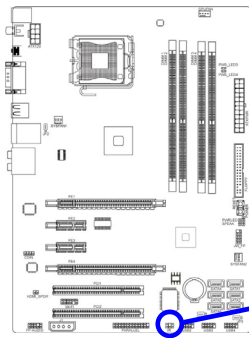

**IR infrared module Header**

**(11) Parallel Port Header (25-pin male): PARALLEL**

The onboard parallel port header is a 25-pin connector for connecting devices such as old-fashioned printer.

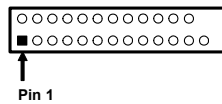
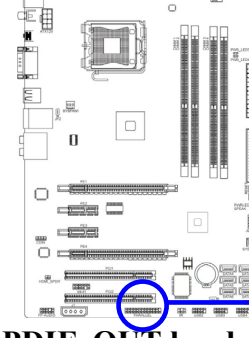

**PARALLEL Connector**

**(12) SPDIF\_OUT header: HDMI\_SPDIF**

The SPDIF output is capable of providing digital audio to external speakers or compressed AC3 data to an external Dolby digital decoder. Use this feature only when your stereo system has digital input function.

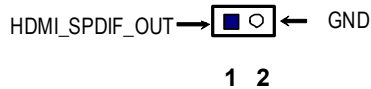
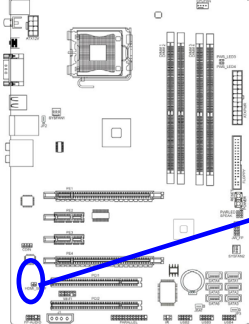

**HDMI\_SPDIF Header**

**(13) Wi-Fi header: WI-FI**

This header supports WI-FI Function. Connect the wireless local area network adapter to this header. It allows you to create a wireless environment and enjoy the convenience of wireless network connectivity.

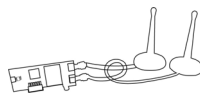
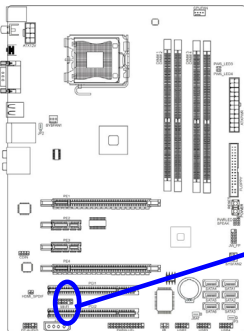

**WI-FI Adapter**

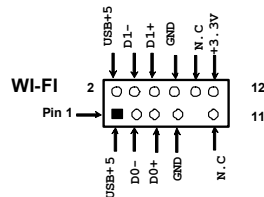

**WI-FI Headers**



---

---

## 2-7 Starting Up Your Computer

1. After all connection is made, close your computer case cover.
2. Be sure all the switch are off, and check that the power supply input voltage is set to proper position, usually in-put voltage is 220V~240V or 110V~120V depending on your country's voltage used.
3. Connect the power supply cord into the power supply located on the back of your system case according to your system user's manual.
4. Turn on your peripheral as following order:
  - a. Your monitor.
  - b. Other external peripheral (Printer, Scanner, External Modem etc...)
  - c. Your system power. For ATX power supplies, you need to turn on the power supply and press the ATX power switch on the front side of the case.
5. The power LED on the front panel of the system case will light. The LED on the monitor may light up or switch between orange and green after the system is on. If it complies with green standards or if it is has a power standby feature. The system will then run power-on test. While the test are running, the BIOS will alarm beeps or additional message will appear on the screen.

If you do not see any thing within 30 seconds from the time you turn on the power. The system may have failed on power-on test. Recheck your jumper settings and connections or call your retailer for assistance.

6. During power-on, press <Delete> key to enter BIOS setup. Follow the instructions in BIOS SETUP.
7. **Power off your computer:** You must first exit or shut down your operating system before switch off the power switch. For ATX power supply, you can press ATX power switching after exiting or shutting down your operating system. If you use Windows 9X, click "**Start**" button, click "**Shut down**" and then click "**Shut down the computer?**" The power supply should turn off after windows shut down.

---

---

# Chapter 3

## Introducing BIOS

The BIOS is a program located on a Flash Memory on the motherboard. This program is a bridge between motherboard and operating system. When you start the computer, the BIOS program will gain control. The BIOS first operates an auto-diagnostic test called POST (power on self test) for all the necessary hardware, it detects the entire hardware device and configures the parameters of the hardware synchronization. Only when these tasks are completed done it gives up control of the computer to operating system (OS). Since the BIOS is the only channel for hardware and software to communicate, it is the key factor for system stability, and in ensuring that your system performance as its best.

In the BIOS Setup main menu of Figure 3-1, you can see several options. We will explain these options step by step in the following pages of this chapter, but let us first see a short description of the function keys you may use here:

- Press <Esc> to quit the BIOS Setup.
- Press ↑↓←→ (up, down, left, right) to choose, in the main menu, the option you want to confirm or to modify.
- Press <F10> when you have completed the setup of BIOS parameters to save these parameters and to exit the BIOS Setup menu.
- Press <+>/<-> keys when you want to modify the BIOS parameters for the active option.

### 3-1 Entering Setup

Power on the computer and by pressing <Del> immediately allows you to enter Setup.

If the message disappears before your respond and you still wish to enter Setup, restart the system to try again by turning it OFF then ON or pressing the “RESET” button on the system case. You may also restart by simultaneously pressing <Ctrl>, <Alt> and <Delete> keys. If you do not press the keys at the correct time and the system does not boot, an error message will be displayed and you will again be asked to

**Press <Del> to enter Setup**

### 3-2 Getting Help

#### Main Menu

The on-line description of the highlighted setup function is displayed at the bottom of the screen.

#### Status Page Setup Menu/Option Page Setup Menu

Press F1 to pop up a small help window that describes the appropriate keys to use and the possible selections for the highlighted item. To exit the Help Window, press <Esc>.

---

---

### 3-3 The Main Menu

Once you enter AMI BIOS Setup Utility, the Main Menu (Figure 3-1) will appear on the screen. The Main Menu allows you to select from 12 setup functions and 2 exit choices. Use arrow keys to select among the items and press <Enter> to accept or enter the sub-menu.

CMOS Setup Utility-Copyright(C)1985-2009 American Megatrends. Inc.

<ul style="list-style-type: none"><li>➤ <b>Standard BIOS Features</b></li><li>➤ <b>Advanced BIOS Features</b></li><li>➤ <b>Advanced Chipset Features</b></li><li>➤ <b>Integrated Peripherals</b></li><li>➤ <b>Power Management Setup</b></li><li>➤ <b>PnP/PCI Configurations</b></li><li>➤ <b>PC Health Status</b></li></ul>	<ul style="list-style-type: none"><li>➤ <b>Miscellaneous Control</b></li><li><b>Load Optimized Defaults</b></li><li><b>Load Standard Defaults</b></li><li><b>Set Supervisor Password</b></li><li><b>Set user password</b></li><li><b>Save &amp; Exit Setup</b></li><li><b>Exit Without Saving</b></li></ul>
<p>↑↓→←: Move Enter: Select +/-: Value F10: Save ESC: Exit F1: General Help F5: Previous Values F6: Optimized Defaults F7: Standard Defaults</p>	

Figure 3-1

#### **Standard BIOS Features**

Use this Menu for basic system configurations.

#### **Advanced BIOS Features**

Use this menu to set the Advanced Features available on your system.

#### **Advanced Chipset Features**

Use this menu to change the values in the chipset registers and optimize your system's performance.

#### **Integrated Peripherals**

Use this menu to specify your settings for integrated peripherals.

#### **Power Management Setup**

Use this menu to specify your settings for power management.

#### **PnP/PCI Configurations**

Use this menu to specify your PnP/PCI configurations.

#### **PC Health Status**

This entry shows your PC health status.

#### **Miscellaneous Control**

Use this menu to specify your settings for Miscellaneous Control.

#### **Load Optimized Defaults**

Use this menu to load the BIOS default values that are factory settings for optimal performances system operations.

#### **Load Standard Defaults**

Use this menu to load the BIOS default values for the minimal/stable performance system operation.

#### **Password Settings**

Use this menu to set User and Supervisor Passwords.

#### **Save & Exit Setup**

Save CMOS value changes to CMOS and exit setup.

#### **Exit Without Saving**

Abandon all CMOS value changes and exit setup.

## 3-4 Standard BIOS Features

The items in Standard CMOS Setup Menu are divided into several categories. Each category includes no, one or more than one setup items. Use the arrow keys to highlight the item and then use the <+> or <-> and numerical keyboard keys to select the value you want in each item.

**CMOS Setup Utility-Copyright(C)1985-2009 American Megatrends. Inc.**  
**Standard BIOS Features**

<b>System Date</b>	<b>Web 05/27/2009</b>	<b>Help Item</b>
<b>System Time</b>	<b>00:09:21</b>	
<b>SATA Channel 1 Master</b>	<b>Not Detected</b>	<b>Select the Type of</b>
<b>SATA Channel 2 Master</b>	<b>Not Detected</b>	<b>Floppy diver</b>
<b>SATA Channel 3 Master</b>	<b>Not Detected</b>	<b>Connected to the system</b>
<b>SATA Channel 4 Master</b>	<b>Not Detected</b>	
<b>SATA Channel 5 Master</b>	<b>Not Detected</b>	
<b>SATA Channel 6 Master</b>	<b>Not Detected</b>	
<b>FLOPPY A</b>	<b>1.44MB, 3 <math>\frac{1}{2}</math> "</b>	
<b>System Memory</b>		
<b>Size: 1024 MB</b>		
↑↓→←: Move Enter: Select +/-: Value F10: Save ESC: Exit F1:General Help F5: Previous Values F6: Optimized Defaults F7: Standard Defaults		

### System Date

The date format is <day><month><date><year>.

**Day** Day of the week, from Sun to Sat, determined by BIOS. Read-only.

**Month** The month from Jan. through Dec.

**Date** The date from 1 to 31 can be keyed by numeric function keys.

**Year** The year depends on the year of the BIOS.

### System Time

The time format is <hour><minute><second>.

### SATA Channel 1, 2, 3, 4, 5, 6

While entering setup, BIOS auto detest the presence of IDE devices. This displays the status of auto detection of IDE devices.

**Type:** The optional settings are: Not Installed; Auto; CD/DVD and ARMD

**LBA/Large Mode:** The optional settings are Auto; Disabled.

**Block (Multi-Sector Transfer):** The optional settings are: Disabled and Auto.

**PIO Mode: the optional settings are:** Auto, 0, 1, 2, 3 and 4.

**DMA MODE:** the optional settings are Auto, SWDMAn, MWDMAAn, UDMAAn.

**S.M.A.R.T.:** This option allows you to enable the HDD S.M.A.R.T Capability (Self-Monitoring, Analysis and Reporting Technology). The optional settings are Auto; Disabled; and Enabled.

**32 Bit Data Transfer:** the optional settings are: Disabled and Enabled.

### Floppy A

This item is for specific floppy disk drive settings. Select according to the specification of the floppy disk you use.

---

---

## System Memory

This item will show information about the memory modules(s) installed.

## 3-5 Advanced BIOS Features

CMOS Setup Utility-Copyright(C)1985-2009 American Megatrends. Inc.

### Advanced BIOS Features

		Help Item
Virus Warning	Disabled	
> CPU Feature	Press Enter	
> Removable Drives	Press Enter	Specifies the Boot Device
Quick Power on self Test	Enabled	Priority Sequence from Available
1 <sup>ST</sup> Boot Device	1 <sup>ST</sup> FLOPPY DRIVER	Removable Devices.
Boot up Number Status	On	
ACPI	Enabled	
MPS Revision Control for OS	1.4	

↑↓→←: Move Enter: Select +/-: Value F10: Save ESC: Exit F1:General Help  
F5: Previous Values F6: Optimized Defaults F7: Standard Defaults

### Virus Warning

The selection allows you to choose the VIRUS Warning feature for IDE Hard Disk booting sector protection. If this function is enabled and someone attempt to write data into this area, BIOS will show a warning message on screen and alarm beep.

**Disabled** (default) No warning message to appear when anything attempts to access the boot sector or hard disk partition table.

**Enabled** Activates automatically when the system boots up causing a warning message to appear when anything attempts to access the boot sector of hard disk partition table.

### Removable Drives

Specifies the Boot Device Priority sequence from available Removable Drives.

### Quick Power On Self-Test

This category speeds up Power On Self Test (POST) after you power on the computer. If this is set to Enabled, BIOS will shorten or skip some check items during POST.

**Enabled** (default) Enable quick POST

**Disabled** Normal POST

### 1<sup>st</sup> Boot Device

Specifies the boot sequence from the available device. A device enclosed in parenthesis has been disabled in the corresponding type menu.

### Boot Up NumLock Status

The default value is On.

**On** (default) Keypad is numeric keys.

**Off** Keypad is arrow keys.

### APIC Mode

Include ACPI APIC table pointer to RSDT pointer list.

### MPS Version Control For OS 1.4

This option is only valid for multiprocessor motherboards as it specifies the version of the Multiprocessor Specification (MPS) that the motherboard will use.

### 3-5-1 CPU Feature

CMOS Setup Utility-Copyright(C)1985-2009 American Megatrends. Inc.  
CPU Feature

Limit CPU Maxval	Disabled	Help Item
C1E Function	Enabled	
Execute-Disabled Bit Capabili	Enabled	Disabled for Windows XP
Enhanced Intel Speedstep Tec	Enabled	
↑↓→←: Move Enter: Select +/-: Value F10: Save ESC: Exit F1:General Help F5: Previous Values F6: Optimized Defaults F7: Standard Defaults		

#### C1E Function

This should be enabled in order to enabled or disable the “Enhanced Halt State”.

#### Execute-Disable Bit Capabili

When disabled, force the xD feature flag to always return 0.

#### Enhanced Intel Speedstep Tec

Disabled: Disable GV3

Enabled: Enable GV3

### 3-6 Advanced Chipset Features

The Advanced Chipset Features Setup option is used to change the values of the chipset registers. These registers control most of the system options in the computer.

CMOS Setup Utility-Copyright(C)1985-2009 American Megatrends. Inc.  
Advanced Chipset Features

DRAM Timing Settings by SPD	Enabled	Help Item
Memory Hole	Disabled	
		Options
		Enabled Disabled
↑↓→←: Move Enter: Select +/-: Value F10: Save ESC: Exit F1:General Help F5: Previous Values F6: Optimized Defaults F7: Standard Defaults		

#### Memory Hole

The optional settings are: Disabled; 15MB-16MB.

### 3-7 Integrated Peripherals

CMOS Setup Utility-Copyright(C)1985-2009 American Megatrends. Inc.  
Integrated Peripherals

➤ Onboard SATA Function	Press Enter	Help Item
➤ Onboard Device Function	Press Enter	
➤ Onboard Super IO Function	Press Enter	
PWR Status after PWR Failure	Always off	
↑↓→←: Move Enter: Select +/-: Value F10: Save ESC: Exit F1:General Help F5: Previous Values F6: Optimized Defaults F7: Standard Defaults		

#### PWRON After PWR-Fail

The optional settings are: Always On; Always Off and Former-Status.

### 3-7-1 Onboard SATA Device

CMOS Setup Utility-Copyright(C)1985-2009 American Megatrends. Inc.  
Onboard SATA Function

SATA#1 Configuration	Compatible	Help Item
Configure SATA#as	IDE	
SATA#2 Configuration	Enhanced	Options
		Disabled Compatible Enhanced
↑↓→←: Move Enter: Select +/-: Value F10: Save ESC: Exit F1:General Help F5: Previous Values F6: Optimized Defaults F7: Standard Defaults		

#### SATA#1 Configuration

The optional settings are: Disabled; Compatible and Enhanced.

#### Configure SATA#1 as

Press Enter to select the SATA type. The optional settings are: IDE; AHCI.

#### SATA#2 Configuration

The optional settings are: Disabled; Enhanced.

### 3-7-2 Onboard Device Function

CMOS Setup Utility-Copyright(C)1985-2009 American Megatrends. Inc.  
Onboard Device Function

Onboard PCIE LAN Controller	Enabled	Help Item
Onboard PCIE Lan BootRom	Disabled	
High Definition Audio	Enabled	Options
USB Host Controller	Enabled	
USB 2.0 Function	Enabled	
USB keyboard Legacy Support	Enabled	
USB Mouse Legacy Support	Enabled	
USB Storage Legacy Support	Enabled	
USB Mass Storage Device Configuration	Enabled	
Device #1 Emulation Type	USE Storage Drive 2003 Auto	
↑↓→←: Move Enter: Select +/-: Value F10: Save ESC: Exit F1:General Help F5: Previous Values F6: Optimized Defaults F7: Standard Defaults		

#### USB Keyboard/Mouse Legacy Support

This item is to enable legacy support for USB keyboard / mouse.

#### USB Storage Legacy Support

This item is to enable or disable support for USB mass storage devices.

#### Emulation Type

IF Auto, USB devices less than 530MB will be emulated as Floppy and remaining as hard drive. Forced FDD option can be used to force a HDD formatted drive to boot as FDD(Ex, IIP drive) .

### 3-7-3 Onboard Super IO Function

CMOS Setup Utility-Copyright(C)1985-2009 American Megatrends. Inc.

Onboard Super IO Function

Onboard Floppy Controller	Enabled	Help Item
Serial Port1 Address	378/IRQ4	
Serial Port2 Address	Disabled	Allow BIOS to Enable or Disable Floppy Controller
Parallel Port Address	378	
Parallel Port Mode	Normal	
↑↓→←: Move Enter: Select +/-: Value F10: Save ESC: Exit F1:General Help F5: Previous Values F6: Optimized Defaults F7: Standard Defaults		

#### Serial Port1/2 Address

This item allows BIOS to select serial port1/2 base address.

#### Parallel Port Address

This item allows BIOS to select parallel port base address.

#### Parallel Port Mode

This item allows BIOS to set parallel mode. The optional settings are: Normal; Bi-Directional; ECP; EPP; ECP&EPP.

### 3-8 Power Management Setup

The Power Management Setup allows you to configure your system to most effectively save energy saving while operating in a manner consistent with your own style of computer use.

CMOS Setup Utility-Copyright(C)1985-2009 American Megatrends. Inc.

Power Management Setup

ACPI Function	Enabled	Help Item
Video off in Suspend	Yes	
Suspend Mode	Disabled	Options
Soft-off by PWR-BTTN	Instant-OFF	
Wake-up by PCI Card	Disabled	
Power on By Ring	Disabled	Disabled
Wake-up by USB from S4	Disabled	Enabled
PS2 KB/MS Wake-up from S4-S5	Disabled	
Resume by Alarm	Disabled	
↑↓→←: Move Enter: Select +/-: Value F10: Save ESC: Exit F1:General Help F5: Previous Values F6: Optimized Defaults F7: Standard Defaults		

#### ACPI Function

This item allows you to Enabled/Disabled the Advanced Configuration and Power Management (ACPI). The settings are Enabled and Disabled.

#### Video Off In Suspend

Power Down video in suspend or standly Mode.

#### Suspend Mode

This item is used for computer to go into suspend mode in Specified time.

#### Soft-Off by PWRBTN

This item is used for computer to go into in/off, or suspend mode when power button is pressed,

#### Resume by Alarm

Disable/Enable RTC to generate a wake event.



## 3-9 PnP/PCI Configurations

CMOS Setup Utility-Copyright(C)1985-2009 American Megatrends. Inc.  
PnP/PCI Configuration

IRQ Resources PCI/VGA Palette Snoop	Press Enter Disabled	Help Item
↑↓→←: Move Enter: Select +/-: Value F10: Save ESC: Exit F1:General Help F5: Previous Values F6: Optimized Defaults F7: Standard Defaults		

### PCI/VGA Palette Snoop

This item is designed to overcome problems that can be caused by some non-standard VGA cards. This board includes a built-in VGA system that does not require palette snooping so you must leave this item disabled.

### IRQ Resources

Names the interrupt request (IRQ) line assigned to the USB on your system. Activity of the selected IRQ always awakens the system. The optional settings are: Available; Reserved.

Available: Specified IRQ is available to be used by PCI/PnP devices. Reserved: Specified IRQ is reserved for use by Legacy ISA devices.

## 3-10 PC Health Status

This section shows the Status of you CPU, Fan, and Warning for overall system status. This is only available if there is Hardware Monitor onboard.

CMOS Setup Utility-Copyright(C)1985-2009 American Megatrends. Inc.  
PC Health Status

Shutdown Temperature	Disabled	Help Item
CPU Thermal-Throttling	Disabled	Options
➤ Smart Fan Configurations	Press Enter	Disabled
CPU Temperature	35°C/93°F	60°C/140°F
System Temperature	32/89	65°C/149°F
CPU FAN Speed	3092Rrpm	70°C/158°F
SYSFAN1 Speed	N/A	75°C/167°F
SYSFAN2 Speed	N/A	
Vcore	1.312v	
NB Core	1.128v	
+5v	4.918v	
+12v	11.918v	
5VSB	5.087v	
DRAM Voltage	1.552v	
Vcc3v	3.408v	
3VSB	3.424v	
VBat	3.328v	
↑↓→←: Move Enter: Select +/-: Value F10: Save ESC: Exit F1:General Help F5: Previous Values F6: Optimized Defaults F7: Standard Defaults		

### Shutdown Temperature

This item can let users setting the Shutdown temperature, when CPU temperature over this setting the system will auto shutdown to protect CPU.

## H/W Health Function

It displays information list below when set as below. The choice is either Enabled or Disabled.

**CPU Temperature/ System Temperature/CPUFAN/SYSFAN1 Speed/SYSFAN2 Speed /Vcore/NBCore/+5V/+12V/5VSB/DRAM Voltage/Vcc3V/3VSB/VBat**

This will show the CPU/ /System voltage chart and FAN Speed, etc.

## 3-10-1 Smart FAN Configuration

CMOS Setup Utility-Copyright(C)1985-2009 American Megatrends. Inc.

### Smart FAN Configuration

<b>CPU FAN Smart Mode</b>	<b>Enabled</b>	<b>Help Item</b> Fan Configuration Mode Setting
<b>CPUFAN Full-Speed Temp</b>	<b>050</b>	
<b>CPUFAN Idle Temp</b>	<b>030</b>	
<b>CPUFAN Idle-Speed Duty</b>	<b>050</b>	
↑↓→←: Move Enter: Select +/-: Value F10: Save ESC: Exit F1:General Help F5: Previous Values F6: Optimized Defaults F7: Standard Defaults		

### CPU Full-Speed Temp

User can set CPU Full-Speed Temp. in the range of 30 ~100.

### CPU Idle Temp.

User can set the CPU idle temp. in the range of 30~100.

### CPU idle-Speed Duty

User can set CPU idle-Speed duty in the range of 0~100.

## 3-11 Miscellaneous Control

CMOS Setup Utility-Copyright(C)1985-2009 American Megatrends. Inc.

### Miscellaneous Control

<b>CPU Clock Ratio</b>	<b>10</b>	<b>Help Item</b>
<b>Auto Detect PCI Clock</b>	<b>Enabled</b>	
<b>Spread Specturum</b>	<b>Disabled</b>	
<b>CPU Diff AMP</b>	<b>800MV</b>	
<b>Linear PCI EX Clock</b>	<b>100</b>	
<b>*** Current DRAM Clock is</b>	<b>800MHz ***</b>	
<b>DRAM Clock at Next Boot is</b>	<b>Auto</b>	
<b>*** Current Host/PCI Clock is</b>	<b>200/33MHz ***</b>	
<b>Host/PCI Clock at Next Boot</b>	<b>200</b>	
<b>CPU PLL Select</b>	<b>1.500V (Default)</b>	
<b>SB Core select</b>	<b>1.500V (Default)</b>	
<b>CPU VTT Select</b>	<b>Default</b>	
<b>NB Core select</b>	<b>1.125V (Default)</b>	
<b>DRAM Voltage Select</b>	<b>1.592V (Default)</b>	
<b>CPU Vcore x-shift</b>	<b>+0.00V (Default)</b>	
↑↓→←: Move Enter: Select +/-: Value F10: Save ESC: Exit F1:General Help F5: Previous Values F6: Optimized Defaults F7: Standard Defaults		

### CPU Clock Ratio:

Sets the ratio between CPU Core clock and the FSB Frequency.

Note: For cedermill and Prescott family CPUS, the setup option only available when Intel speed step technology is disabled.

### CPU PLL Select

The optional settings are from 1.500V(Default)to 3.031V.

---

---

### **SB Core Select**

The optional settings are from 1.500V(Default)to 3.031V.

### **CPU VTT Select**

The optional settings are from +1.91% to 120.09%.

### **DRAM Voltage Select**

This item allows you to set DRAM voltage. Motherboards based on different chipset series have different voltage range.

### **Host/PCI Clock at Next Boot**

This item allows user to set CPU/PCI clock frequency.

### **NB Core Select**

This item allows you to select value of Voltage for North Bridge Chipset. Motherboards based on different chipset series may have different setting range.

### **Linear PCIE X Clock**

This item allows you to set Linear PCI Ex clock frequency. Motherboards based on different chipset series have different setting range.

### **DRAM Clock at Next Boot**

This item allows you to set DRAM clock frequency at next boot.

### **CPU Vcore X-Shift**

This item allows you to over-clock precisely in the preset range from -0.80V to +0.63V.

## **3-12 Password Setting**

You can set either supervisor or user password, or both of them. The differences are:

**Supervisor password:** Can enter and change the options of the setup menus.

**User password:** Can only enter but do not have the right to change the options of the setup menus. When you select this function, the following message will appear at the center of the screen to assist you in creating a password.

#### **ENTER PASSWORD:**

Type the password, up to eight characters in length, and press <Enter>. The password typed now will clear any previously entered password from CMOS memory. You will be asked to confirm the password. Type the password again and press <Enter>. You may also press <Esc> to abort the selection and not enter a password.

To disable a password, just press <Enter> when you are prompted to enter the password. A message will confirm that the password will be disabled. Once the password is disabled, the system will boot and you can enter Setup freely.

#### **PASSWORD DISABLED.**

When a password has been enabled, you will be prompted to enter it every time you try to enter Setup. This prevents an unauthorized person from changing any part of your system configuration.

Additionally, when a password is enabled, you can also require the BIOS to request a password every time your system is rebooted. This would prevent unauthorized use of your computer.

You determine when the password is required within the BIOS Features Setup Menu and its Security option. If the Security option is set to “Always”, the password will be required both at boot and at entry to Setup. If set to “Setup”, prompting only occurs when trying to enter Setup.

---

---

### 3-13 Load Standard Defaults /Load Optimized Defaults

#### Load Standard Defaults

When you press <Enter> on this item, you get a confirmation dialog box with a message similar to:

Load Standard Defaults?  
【OK】      【Cancel】

Pressing <OK> loads the default values that are factory settings for stable performance system operations.

#### Load Optimized Defaults

When you press <Enter> on this item, you get a confirmation dialog box with a message similar to:

Load Optimized Defaults?  
【OK】      【Cancel】

Pressing <OK> loads the default values that are factory settings for optimal performance system operations.

### 3-14 Save & Exit Setup / Exit Without Saving

#### Save & Exit Setup

When you press <Enter> on this item, you get a confirmation dialog box with a message similar to:

Save configuration changes and exit setup?  
【OK】      【Cancel】

Pressing <OK> save the values you made previously and exit BIOS setup.

#### Exit Without Saving?

When you press <Enter> on this item, you get a confirmation dialog box with a message similar to:

Discard Changes and Exit Setup?  
【OK】      【Cancel】

Pressing <OK> to leave BIOS setting without saving previously set values.

**Notice!** The BIOS options in this manual are for reference only. Different configurations may lead to difference in BIOS screen and BIOS screens in manuals are usually the first BIOS version when the board is released and may be different from your purchased motherboard. Users are welcome to download the latest BIOS version form our official website.

---

---

## Chapter 4

### DRIVER & FREE PROGRAM INSTALLATION

Check your package and there is A CD included. This CD consists of all DRIVERS you need and some free application programs and utility programs. In addition, this CD also include an auto detect software which can tell you which hardware is installed, and which DRIVERS needed so that your system can function properly.

#### Supports WINDOWS 2000/ XP/ VISTA/ 7

Insert CD into your CD-ROM drive and the Menu should appear as below. If the menu does not appear, double-click MY COMPUTER / double-click CD-ROM drive or click START / click RUN / type X:\INTEL.EXE (assuming X is your CD-ROM drive).

#### The Intel P45 chipset driver only of Windows 2000/ Windows XP/ VISTA/ 7 Windows XP/ VISTA/ 7



#### Windows 2000



---

---

**From MENU you may make as selections:**

1. INF                   install Intel INF chipset system driver
2. LAN                   install Gigabit Ethernet NIC Driver
3. SOUND               install ALC883 HD Audio Codec driver
4. AHCI                 install Intel AHCI Driver
5. BROWSE CD         to browse the contents of the CD

---

---

## 4-1 INF: Install Intel INF Chipset System Driver

Windows XP/ VISTA/ 7



Windows 2000



---

---

## 4-2 LAN: Gigabit Ethernet LAN Driver

Windows XP/ VISTA/ 7



Windows 2000





---

---

## 4-3 SOUND: Install ALC883 HD Audio Codec Driver

Windows XP/ VISTA/ 7



Windows 2000



---

---

## 4-4 AHCI: Install Intel AHCI Driver

Windows XP/ VISTA/ 7

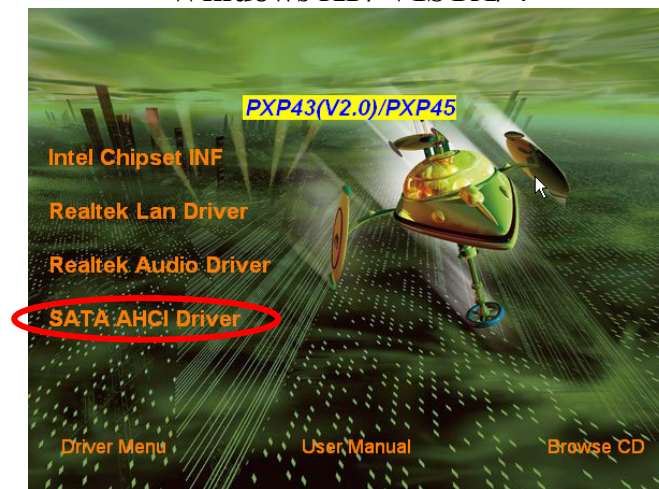

**Intel AHCI Driver does not support Windows 2000**

---

---

## 4-5 How to Update BIOS

- Step 1.** Prepare a bootable disk. (You may make one by click START click RUN type SYS A: click OK)
- Step 2.** Download upgrade tools and the latest BIOS files of the motherboard from official website and then make a copy of it to your bootable disk after decompressing these files
- Step 3.** Insert the disk into A: ,start your computer and enter BIOS setup to set the bootable disk as the first boot device, save the settings before you exit BIOS setup, restart the computer, then type in “A:\xxxxxx.BAT”(xxxxxxx being the file name of the latest BIOS )
- Step 4.** Type Enter to update and flash the BIOS. The system will restart automatically when BIOS is upgraded.

---

---

## 4-6 G.P.I FUNCTION LED Display

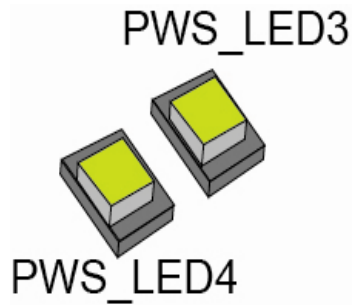

All lights off. It means the motherboard in the G.P.I mode. CPU works with the low power consumption.

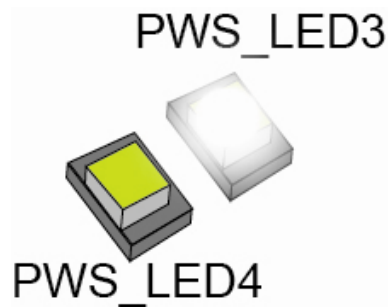

One light on. It means that there are two phases PWM are supplying the power. The computer is in the mode of saving energy.



Two lights on. It means that the CPU works with high power consumption.