

**ZANUSSI**

---

**Instructions  
for the use and care of  
Z1142TRM - Z1162TRM  
refrigerators**

---

# Installation

## Foreword

If you are discarding an old refrigerator that has a lock on the door, please ensure that the lock is made unusable to avoid accidents to young children.

## Electricity Supply

The appliance is for operation on a 220/240 V. 50 Hz supply, so be sure that your electricity supply voltage is within the range marked on the nameplate located inside the cabinet.

## Earthing

**WARNING: THIS APPLIANCE MUST BE EARTHED.** The manufacturer declines any liability should this safety measure not be observed.

If the plug that is fitted to your appliance is not suitable for your socket outlet, it must be cut off and the appropriate plug fitted. The cut off plug should be disposed of to prevent the hazard of electric shocks in case it should be plugged into a 13 Amp socket in another part of your home.

## Electrical connection

**IMPORTANT:** The wires in this mains lead are coloured in accordance with the following code:

GREEN AND YELLOW - EARTH  
BLUE - NEUTRAL  
BROWN - LIVE

If you fit your own plug, the colours of the wires in the mains lead of your appliance may not correspond with the markings identifying the terminals in your plug, this is what you have to do: Connect the green and yellow (earth) wire to the terminal in the plug which is marked with the letter "E" or the earth symbol  $\perp$ , or coloured green, or green and yellow.

Connect the blue (neutral) wire to the terminal in the plug which is marked with the letter "N" or coloured black.

Connect the brown (live) wire to the terminal which is marked with the letter "L" or coloured red.

The plug moulded on to the cord incorporates a fuse. For replacement use a 13 Amp BS 1362 fuse. Only ASTA approved fuses should be used.

The fuse cover/carrier must be replaced in the event of changing fuse.

The right fuse cover/carrier colour is the one shown by the coloured insert at the base of the plug.

The plug must not be used if the fuse cover/carrier is lost.

A replacement cover/carrier must be obtained from Zanussi Service Agents whose addresses are listed on the attached "Zanussi Service and Spares Nationwide".

**This appliance complies with E.E.C. directive NO. 76/889 of 4.11.76 relative to radio interference suppression.**

Some models have the main terminal board of the type shown in fig.1.

To gain access to the terminals of the supply cable, remove the lid from the terminal board by releasing the two catches "A" and "B" Fig.1 with the aid of a small blade screwdriver.

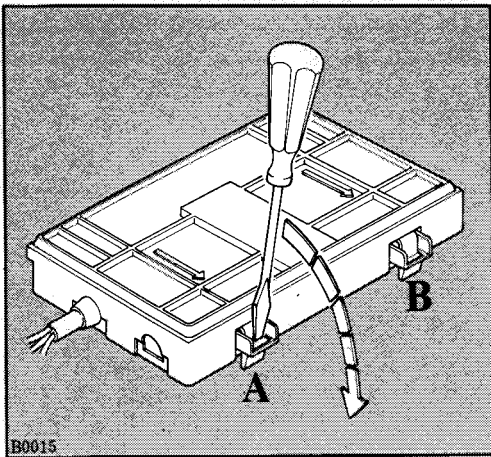

Fig. 1

## Location and levelling

Place the appliance away from heat sources and in such a way that air can circulate freely to the back and around the top of the cabinet. Level by adjusting the special levelling feet on the bottom of the cabinet.

## Before using

Remove all securing tapes. Wash inside the appliance with lukewarm water and a little bicarbonate of soda (one teaspoonful to one quart of water). Do not use soap or detergent as the smell might linger. Dry thoroughly.

# Operation

## Refrigerator - Starting-up -Temperature Regulation

Insert the plug into the wall socket. Open the refrigerator door and turn the thermostat knob, to be found on the upper right side of the inner liner, clockwise beyond the position (stop) to start the appliance.

Temperature adjustment is obtained by turning the thermostat knob to the required setting. A medium setting is generally the most suitable.

However, the thermostat knob setting should be adjusted depending on the inner temperature of the refrigerator, which in turn depends on a number of factors, such as the ambient temperature, the number of times the door is opened, the quantity of food stored and the location of the appliance.

Turn the knob clockwise to higher numbers to obtain a lower temperature or anticlockwise if a less cold temperature is required.

## Cold air flow control from the **\*\*** star compartment to refrigerator cabinet

The conveyor to be found under the **\*\*** star compartment can be adjusted in order to get a correct temperature balancing between the **\*\*** star compartment and the refrigerator cabinet.

When the ambient temperature is lower than 25°C (77°F) slightly raise the conveyor and push it all the way in.

When the ambient temperature is higher than 25°C (77°F) return the conveyor to its initial position in order to permit a higher cold air flow into the refrigerator cabinet.

## Frozen food storage

Net frozen food storage volume:

Model Z1142TRM 9 litres

Model Z1162TRM 10.5 litres

Total gross capacity:

Model Z1142TRM 140 litres

Model Z1162TRM 160 litres

The refrigerators model Z1142TRM Z1162TRM have a storage compartment marked with the 2-star symbol (**\*\***) which due to the low temperature reached (-12°C), is suitable for medium term storage of frozen foods (i.e. 1 month, unless otherwise stated by the manufacturer).

Do not exceed the storage limits for the rating of the frozen food packets given by the manufacturer.

**Attention:** Do not put carbonated liquids (fizzy drinks, etc.) into the **\*\*** star compartment.

Water ices, if consumed immediately after removal from the freezer, can possibly result in a low-temperature skin burn condition.

If there is a power failure during the storage of frozen food, do not open the door during the whole time of the failure. If the freezer is fully loaded, the frozen food will not be affected if the power cut is of short duration (a temperature increase can shorten its storage life); otherwise, it is recommended to consume the food within a very short time.

## Fresh food refrigeration

To obtain the best performance, do not store warm food or evaporating liquids in the refrigerator, do cover or wrap the food, particularly if it has a strong flavour;

do not cover the shelves with any protective material, such as paper, cardboard or plastic, which may obstruct the air circulation through them.

To help you use your refrigerator correctly, here are some useful hints: Row meat (beef, pork, lamb & wild fowl): wrap in polythene bags and place on the first shelf under the **\*\*** star

compartment. Meat can only be stored safely in this way for two or three days at the most.

Cooked food, cold cuts, jelly, etc.: these should be well covered and can be stored on anyone of the shelves.

Fruit & vegetables: these should be thoroughly cleaned and placed in the bottom drawers.

Butter & cheese: these should be placed in special airtight containers or wrapped in aluminium foil or polythene bags to exclude as much air as possible.

Milk bottles: these should have a cap and should be stored in the bottle rack on the door.

## Drink-chiller

(For models incorporating a drinks dispenser)

The container for cooling drinks, which is located on the inner door or - depending on the model of appliance - on the ceiling of the fridge compartment, can easily be removed from its runners for filling.

To pour out a drink, press the glass upwards, against the tap arms.

Upon removing the glass, the tap turns itself off.

To clean the container, we recommend that you rinse it several times with hot water after letting the water cool down inside the container itself.

It also helps, for a thorough cleaning of the container, to add a spoonful of baking soda to the rinsing water. Turn the dispenser tap on and off a number of times to allow sugar deposits from soft drinks or sweet wines to dissolve.

Empty the container and rinse with clean water.

## Defrosting

While in operation the **\*\*** star evaporator compartment becomes progressively covered with frost. This frost, which acts as an insulator and thus prevents the cold from reaching the food should be removed whenever the thickness of the frost exceeds 1/4".

To carry out complete defrosting proceed as follows:

### When no foods are stored in the **\*\***-star compartment

Place the plastic tray, supplied with the appliance, on the first shelf in correspondence with the drain hole on the conveyor;

Push the button at the center of the thermostat knob. When defrosting is completed, operation is resumed automatically. After defrosting, remove the water collected in the tray.

### When foods are stored in the **\*\***-star compartment

Place the pastic tray supplied with the appliance, on the first shelf in correspondence with the drain hole on the conveyor.

Remove from the compartment any stored food and wrap it in several layers of newspaper and put it in a cool place. Pull out the plug from the wall socket; Leave the doors open;

When defrosting is completed, dry thoroughly;

Remove the water collected in the tray. Replace the plug in the socket and, after letting the appliance run for at least half an hour, replace the previously removed food into the compartment.

When defrosting it is not necessary to remove the foods from the inner door and cabinet of the refrigerator.

### Important:

A temperature rise of the frozen food packs during defrosting may shorten their storage life.

Never use sharp metal tools to scrape off frost from the evaporator as you could thereby damage it.

# Maintenance

Prior to undertaking any maintenance operation, be sure to unplug the appliance from the wall socket as a safety precaution. Clean out the interior periodically with lukewarm water and some bicarbonate of soda, the cabinet exterior with a Silicone wax spray, the condenser and the motor compressor with a brush or a vacuum cleaner. During periods when the appliance is not in use, take the following precautions: unplug the refrigerator from the power supply; remove all foodstuffs from the refrigerator; clean the interior and all accessories; leave the door ajar to facilitate the circulation of air in the interior of the cabinet so as to prevent unpleasant odours from lingering in the appliance.

# Servicing

Should service be required for this appliance, contact your local Service Agent but before requesting service the following simple checks may save you inconvenience and expense:

Check that the plug is firmly in the wall socket;

Check that there is an electricity supply to the socket by plugging in another appliance;

Turn the thermostat knob to the coldest setting;

If the motor still does not run, contact your Service Agent.

# Door reversal directions (Fig.2)

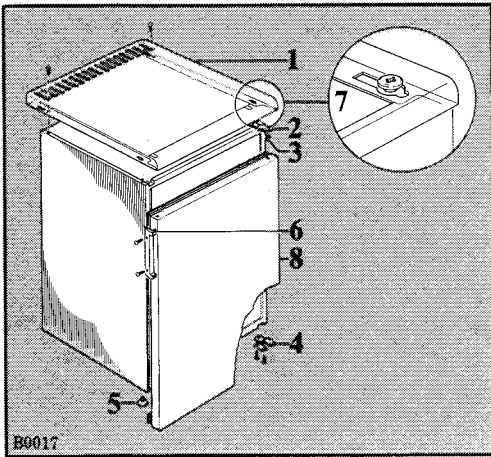

Fig. 2

Before carrying out the operations described below, pull out the mains plug from the wall socket.

Proceed as follows:

- a. To take off the table top, first remove the two rear fixing screws (1), then slide it out from slots (7).
- b. Remove the upper hinge (2).
- c. Slide out the door (8).
- d. Remove pivot (3) from hinge (2) and refit it in the corresponding hole on the opposite side.
- e. Replace the hinge (2) on the opposite side.
- f. Unscrew foot (5) and remove hinge (4), replace the door, refit both the foot and the hinge on the opposite side.
- g. Refit the table top.
- h. Remove the handle (6) and refit it on the opposite side (fixing holes are already provided).

## Positioning the table top

The appliance is delivered with the table top fixed flush with the door.

If a different positioning is required, remove the two rear fixing screws (1), displace the table top to the new location, secure the screws (1).

---

## ZANUSSI GUARANTEE CONDITIONS

This guarantee is in addition to your statutory and other legal rights which will not be excluded or in any way diminished by the return of the enclosed card.

We, IAZ International (UK) Ltd, guarantee that if within twelve months of the date of the purchase, this ZANUSSI appliance or any part thereof is proved to be defective by reason only of faulty workmanship or materials we will at our option repair or replace the same **FREE OF ANY CHARGE** for labour, materials or carriage on condition that:

- The appliance has been correctly installed and used only on the electricity supply stated on rating plate.
- The appliance has been used for normal domestic purposes and in accordance with the manufacturer's operating and maintenance instructions.
- The appliance has not been serviced, maintained, repaired, taken apart or tampered with by any person not authorised by us.

- The appliance is still in the possession of the original purchaser.
- Any appliance or defective part replaced shall become our property.

This guarantee does not cover any damage caused during transportation or the replacement of any light bulbs or removable parts of glass or plastic.

Should you require service on your Zanussi appliance consult the enclosed list for your nearest Zanussi network centre. If the product is under first year guarantee then you will be required to produce proof of date of purchase to the engineer. If it is under 5 year cover then you must show your cover card to the engineer.

Please ensure that the enclosed pre-addressed card is stamped, completed in full and forwarded to IAZ International (UK) Ltd, to enable the guarantee to be recorded. Also complete the space below as your own record of the guarantee.

---

## GUARANTEE RECORD

Appliance purchased from \_\_\_\_\_ on \_\_\_\_\_  
Guarantee card no \_\_\_\_\_ Model no \_\_\_\_\_  
Serial no \_\_\_\_\_ (These details may be taken from your Guarantee Record Card)  
Your name \_\_\_\_\_  
Address \_\_\_\_\_  
\_\_\_\_\_  
\_\_\_\_\_