

Chromalox®

Installation, Operation and **RENEWAL PARTS IDENTIFICATION**

SERVICE REFERENCE

DIVISION 4		SECTION VUH
SALES REFERENCE	(Supersedes PF451-2)	PF451-3
		161-057823-001
DATE JULY, 2002		

Type VUH Vertical Unit Heater

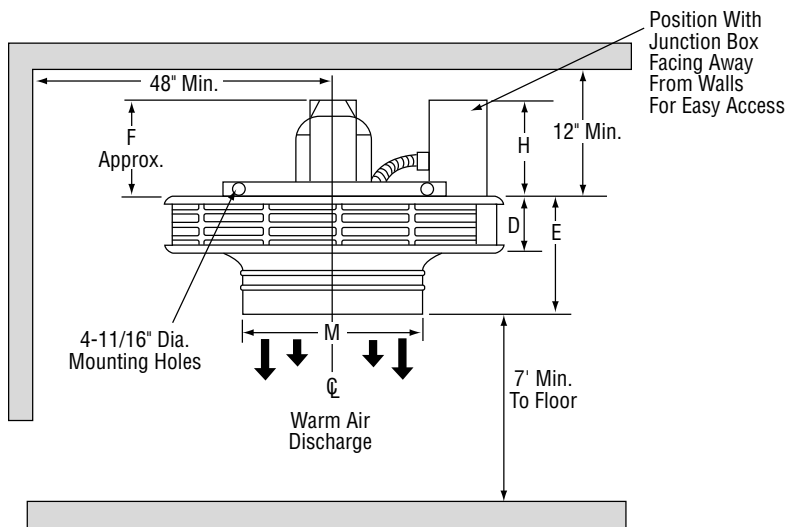

Figure 1

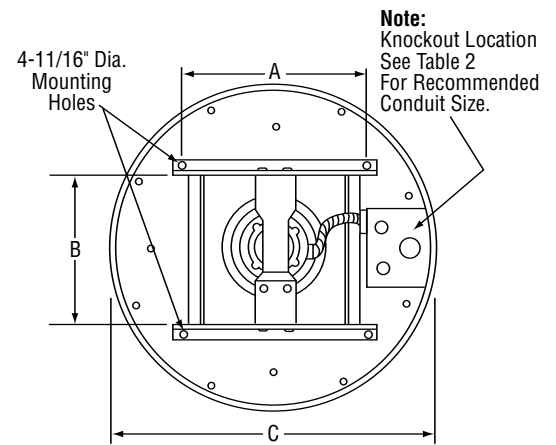

Figure 2

Specifications — Table 1

Model	Heating Capacity		Volts		Air Delivery			Max. Mtg. Height (Ft.)	Dimensions (In.)							Mtg. Weight (Lbs.)	
	kW	BTUH	1 Phase	3 Phase	CFM	FPM	Outlet Temp. °F*		A	B	C	D	E	F	H		M
VUH-C-15	15	51,000	—	208 240 480	1300	1600	93	25	14	13-1/2	26	4-5/8	8-3/8	6	7-1/4	12-5/8	85
VUH-C-20	19.5	68,000	—	208	1300	1600	104	23	14	13-1/2	26	4-5/8	8-3/8	6	7-1/4	12-5/8	85
	20			480													
VUH-C-25	25	85,000	—	480	1300	1600	115	20	14	13-1/2	26	4-5/8	8-3/8	6	7-1/4	12-5/8	85

* Based on 60°F entering air.

** For instructions on VUH units rated 5-10 kW refer to Bulletin PF450; VUH units rated 30-50 refer to Bulletin PF452.

Table 2 - Electrical Data

Model	Power Supply Circuit							Contactor Holding Coil Volt Amperes (Note 3)		Motor		
	kW	Volts	Phase	Line Amps (Note 1)	Line Wire Size (Note 2)	No. Circuits	Minimum Conduit Size † (In.)	Inrush	Sealed	Volts	H.P.	Phase
VUH-C-15	15	208 240 480	3 3 3	43 37 19	6 8 10	1 1 1	1 1 1/2	52	9	208 240 480	1/6	3
VUH-C-20	19.5 20	240 480	3 3	48 25	6 8	1 1	1 3/4	52	9	240 480	1/6	3
VUH-C-25	25	480	3	31	8	1	3/4	52	9	480	1/6	3

Notes:

1. Includes Fan Motor Amps.
 2. Use 75°C Wire - Copper Conductors only.
 3. Standard units have one contactor. Units with separate fan motor control use two contactors.
- † Conduit knockout location - top of Junction Box.

IMPORTANT

Failure to understand and follow these installation instructions and the “WARNING” notes therein may result in serious personal injury from electrical shock, or from the heater falling due to faulty installation.

WARNING: This heater is not recommended for use in hazardous atmospheres where flammable vapors, gases, liquids or other combustible atmospheres are present as defined in the National Electrical Code. Failure to comply can result in explosion or fire. For these applications see Bulletin PDS CXH-EP (PF305).

WARNING: Hazard of Shock. Disconnect all power before installing heater.

The heater must be mounted at least 7’ above the floor to prevent accidental contact with the heating elements or fan blade which could cause injury.

The ceiling structure, the brackets, hangers or chains used to suspend the heater, and the anchoring provisions must be of sufficient strength to support the combined weight of the heater installation (85 pounds for VUH-C-15, 20, 25 plus the weight of the supports).

Prior to operating the heater verify that the fan hub setscrews are tightened and the push-on clip is secured to assure that the fan blade is securely fastened to the motor shaft.

On models connected to three-phase power, fan blade rotation must be checked. If airflow is not downward, interchange any two of the three customer power leads.

First stage of thermostat must be connected to terminals C1 and C2 to insure proper operation of overheat protective devices.

INSTALLATION

WARNING: Hazard of Shock. Any installation involving electric heaters must be effectively grounded in accordance with the National Electrical Code.

1. Heater should be positioned with the junction box facing away from walls to provide easy access for servicing relay(s) mounted within.

WARNING: Mount the heater for down discharge only.

2. It is important that the 12” minimum dimension shown in Figure 1 be maintained to make it possible for a serviceman to remove the fan motor, if necessary, without moving the heater from its mounting.

WARNING: The heater must be mounted at least 7’ above the floor to prevent accidental contact with the heating elements or fan blade which could cause injury.

The ceiling structure, the brackets, hangers or chains used to suspend the heater and the anchoring provisions must be of sufficient strength to support the total weight of the heater installation (85 pounds for VUH-C-15, 20, 25 plus the weight of the supports).

3. The heater may be mounted to the ceiling by attaching rigid angle brackets, hangers, or chains to the four mounting holes on the top of the heater case using four 5/8” bolts (by others). See Figures 1 and 2.

Note: Brackets, hangers, or chains to support the heater are supplied by the customer.

4. All wiring should be done in accordance with local codes and the National Electrical Code by a qualified person as defined in the NEC.

WARNING: Use Copper conductors only.

5. Rough-in wiring to heater. See Table 2 for line amperes, recommended wire size and conduit size.
6. Wire heater per wiring diagram supplied with this instruction sheet.

Note: Power relay(s) are provided as standard on all heaters.

WARNING: Prior to operating the heater, verify that the fan hub setscrews are tightened and the push-on clip is secured to assure that the fan blade is securely fastened to the motor shaft.

7. Carefully inspect the completed installation. Rotate the fan blade by hand to be sure that it turns freely. Investigate any binding, rubbing or interference.
8. Air diffusers for deflecting the air are optional. See Instruction Sheet PF449 for Installation instructions.

MAINTENANCE

WARNING: Hazard of Shock. Disconnect all power to heater before servicing or replacing heaters. Do not attempt to service heater while unit is operating as there is hazard of electric shock, injury from operating fan, and burns from hot heating elements.

1. Before activating for next heating season, vacuum or use compressed air to remove accumulated dust or lint, which otherwise may restrict proper air flow.
2. Periodically check all electrical connections and retighten to avoid electrical wiring difficulties.

WIRING DIAGRAMS

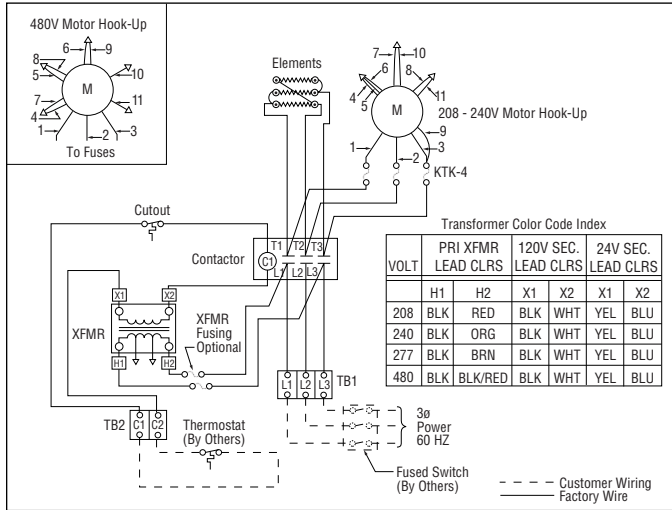

Figure 3

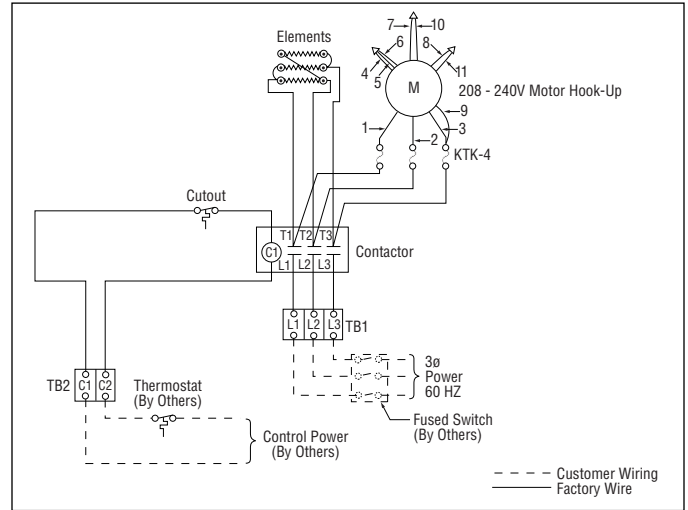

Figure 4

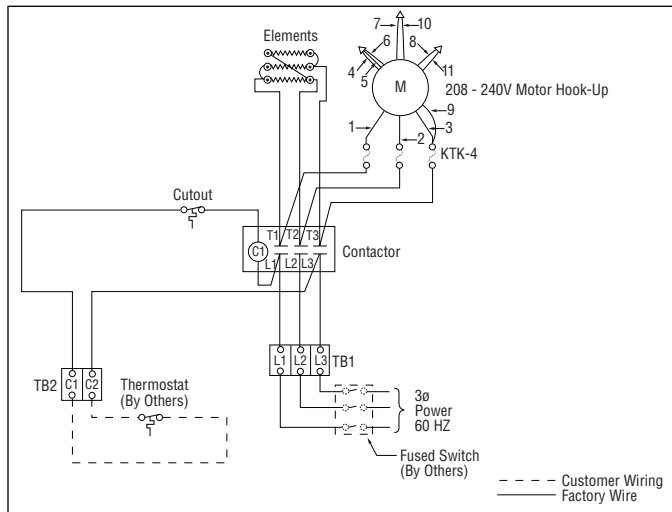

Figure 5

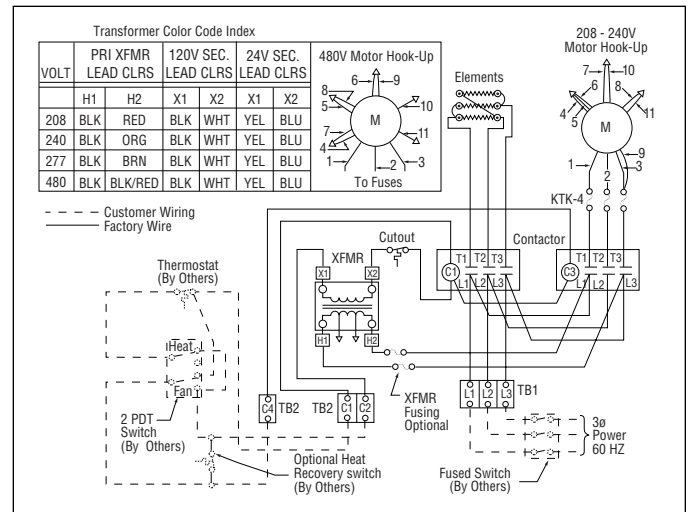

Figure 6

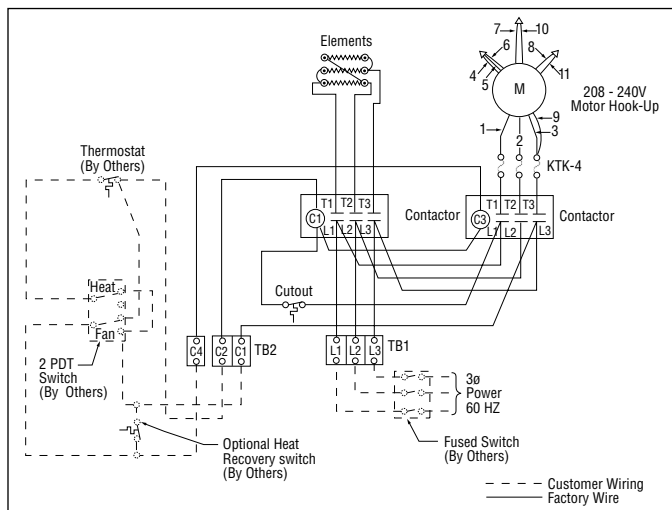

Figure 7

Note: All fan motors are totally enclosed and internally thermal overload protected.

MOTOR LUBRICATION

Motors in VUH-C-15 through VUH-C-25 have sleeve bearings which are factory lubricated.

RENEWAL PARTS IDENTIFICATION

MANUFACTURER PART NUMBER BREAKDOWN (LOCATED ON UNIT NAMEPLATE)

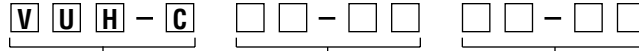

Common Parts

Diagram Item No.	Description	Part No.
4	Fan	112-510499-001
5	Grille	134-130439-001
6	Overheat Cutout	300-024283-004

Controls

Code No.	Description	Part Number	Diag. Item No.	Wiring Dia. Figure	Wiring Diagram Part No.
30-00	Contactor-24V Coil (30A)	072-303180-001	3	3	170-057688-006
	Contactor-24V Coil (50A)	072-303180-002	3		
	Transformer	315-304252-002	7		
31-00	Contactor-24V Coil (30A)	072-303180-001	3	4	170-057688-007
	Contactor-24V Coil (50A)	072-303180-002	3		
32-00	Contactor-120V Coil (30A)	072-303180-007	3	3	170-057688-006
	Contactor-120V Coil (50A)	072-303180-008	3		
	Transformer	315-304252-001	7		
32-45	Contactor-120V Coil (30A)	072-303180-007	3	6	170-057688-009
	Contactor-120V Coil (50A)	072-303180-008	3		
	Transformer	315-304252-001	7		
33-00	Contactor-120V Coil (30A)	072-303180-007	3	4	170-057688-007
	Contactor-120V Coil (50A)	072-303180-008	3		
34-00	Contactor-208/240V Coil (30A)	072-303180-003	3	5	170-057688-008
	Contactor-208/240V Coil (50A)	072-303180-014	3		
34-45	Contactor-208/240V Coil (30A)	072-303180-003	3	7	170-057688-010
	Contactor-208/240V Coil (50A)	072-303180-014	3		

Elements and Motor

Code No.	kW	Volts	Phase	Element Part No. (Item 1)	Motor Part No. (Item 2)
15-83	15	208	3	118-130437-007 (3)	193-057647-001
15-23		240		118-130437-004 (3)	
15-43		480		118-130437-005 (3)	
20-23	19.5	240		118-130437-007 (3)	
20-43	20	480		118-130437-008 (3)	
25-43	25	480		118-130437-011 (3)	

NOTES: Number in parenthesis () indicates quantity required of that part.

Optional Transformer Fusing

Fuse Type	Part No.
KTK-3	128-047763-007 (2)

Motor Fusing

Fuse Type	Part No.
KTK-4	128-047763-008 (3)

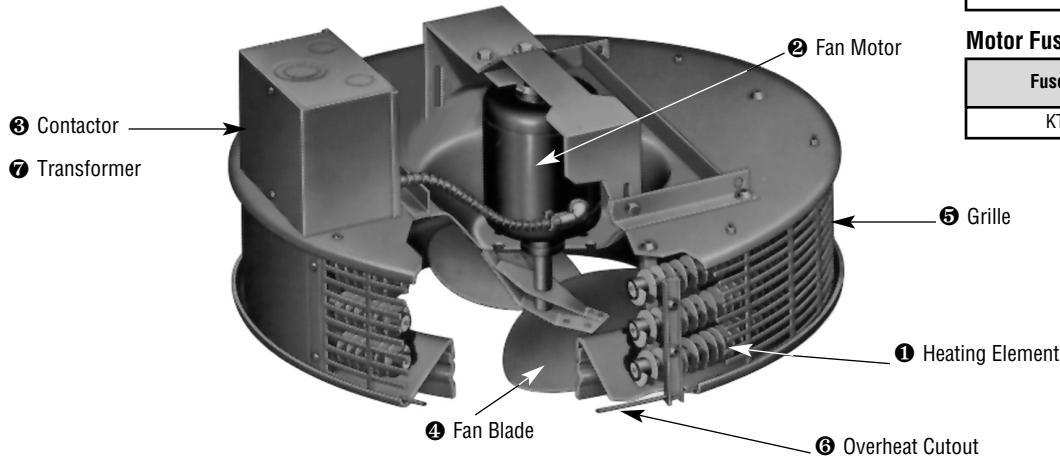

Limited Warranty:

Please refer to the Chromalox limited warranty applicable to this product at http://www.chromalox.com/customer-service/policies/terms_of_sale.aspx.

Chromalox[®]
PRECISION HEAT AND CONTROL

2150 N. RULON WHITE BLVD., OGDEN, UT 84404
Phone: 1-800-368-2493 www.chromalox.com