

SAFETY INSTRUCTION AND OPERATORS MANUAL FOR

SNAPPER

SG 8000

**SHREDDER-
GRINDER-
CHIPPER**



THANK YOU for buying a SNAPPER product! Your SNAPPER SHREDDER-GRINDER-CHIPPER was designed and built to provide long and satisfactory service. Keep in mind that it, like any other mechanical device, can be potentially dangerous if used improperly and that no accident prevention program can be successful without the wholehearted cooperation of the person responsible for the

operation of the equipment. Study this Operator's Manual carefully to learn about operation of all controls and pay particular attention to the Important Safety Precautions on Page 2-4. Following these instructions will help you continue to enjoy the trouble-free operation expected of a SNAPPER product.

SNAPPER® McDonough, GA., 30253 U.S.A.

MANUAL # 1-7629 (IR 8/95)



WARNING

RULES FOR SAFE OPERATION

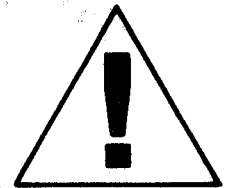

THIS MACHINE IS CAPABLE OF INFLECTING SERIOUS INJURY IF OPERATED IMPROPERLY — READ WARNINGS & CAUTION.

TRAINING AND PREPARATION

Before operating this shredder-chipper-grinder, read and understand this manual completely. Become familiar with it for your own safety. To fail to do so may cause serious injury. Do not allow anyone to operate your machine who has not read this manual.

INTENDED USE

Never use your shredder-chipper-grinder for any other purpose than shredding and chipping gardening products. It is designed for this use only and any other use may cause injury.



DANGER

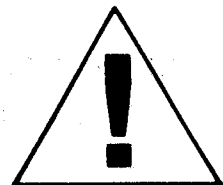

DANGER:

Rotating cutting blades.
Keep hands and feet out of discharge opening while machine is running.

DANGER:

Rotating cutting blades.
Keep hands out of inlet opening while machine is running.

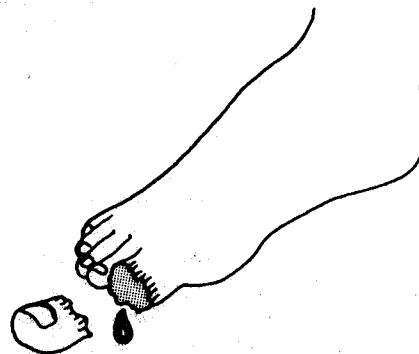
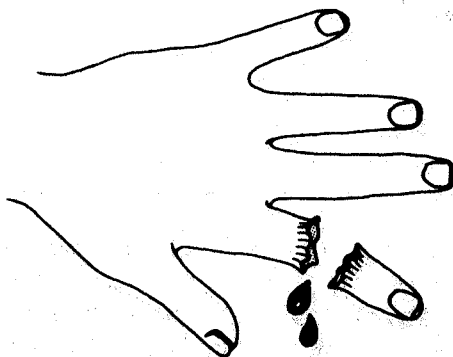

DANGER:

This machine can **CRUSH, GRIND, CUT,** and **SEVER** parts of your body if they enter the inlet or discharge area of your shredder-chipper.

OPERATORS RESPONSIBILITY

Never allow children to operate your shredder-chipper-grinder, nor adults lacking the proper instructions. Keep children, pets, and bystanders a minimum of 20 feet away from your work area. Flying chips can be hazardous.

Never run this machine in an enclosed area since the exhaust from the engine contains carbon monoxide which is an odorless, tasteless, and deadly poisonous gas.

Never run this machine on cement or blacktop. This machine should be operated **ONLY** on a level earthen surface.

Never put your hands, feet, face, or any other part of your body in the feed hopper or discharge area.

Never remove the plastic shield attached to the shredding hopper. This device prevents flyback and must be intact at all times. This is a protective guard. **Never** use the chipper with the chipper hopper removed.

Never operate your shredder-chipper-grinder while under the influence of alcohol, drugs, or medication. A clear mind is essential for safety.

Never allow a person who is tired or otherwise not alert to operate this machine.

SAFETY WEAR

Never wear loose clothing or jewelry that can be caught by moving parts of your shredder-chipper-grinder and pull you into it. Keep all clothing away from moving parts. Wear proper head gear to keep hair away from moving parts.

Always wear safety glasses or goggles, and work gloves at all times while operating your shredder-chipper-grinder. A chip could fly out and hit you in the eye. Be sure your glasses fit properly and your gloves do not have loose cuffs or draw strings.

Always wear ear protectors at all times while operating your shredder-chipper-grinder. The noise of this machine could result in hearing loss.

OPERATING PROCEDURE

Only operate your shredder-chipper-grinder from the operator zone.

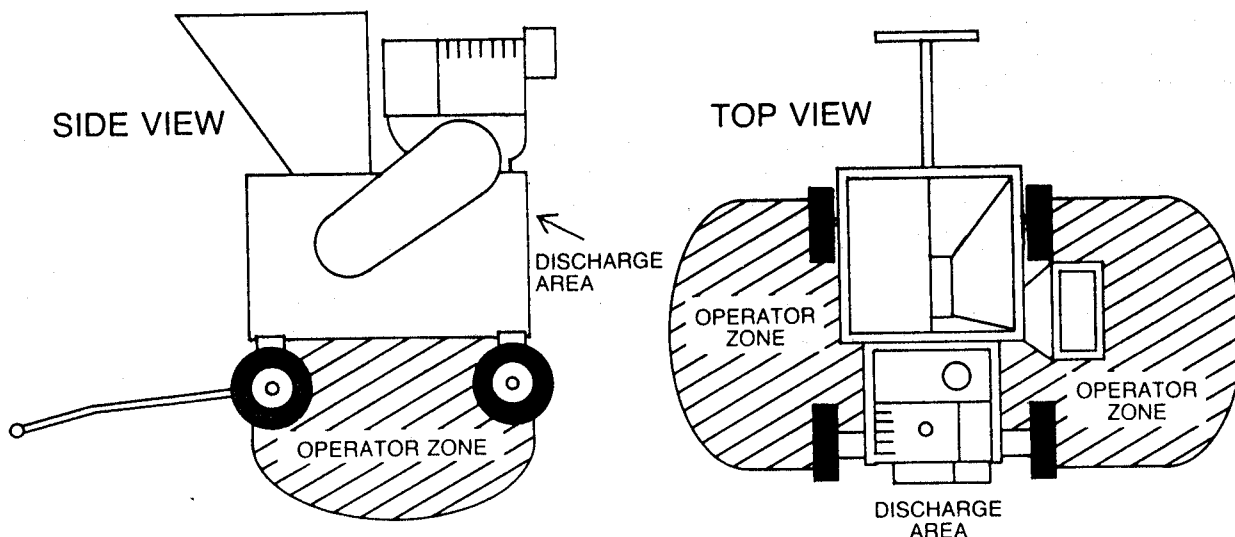

Know how to turn the unit off.

Never clear discharge area with hands, feet, or any other part of your body.

Never clear discharge area while unit is running. After shredder-chipper is shut off, then use a long handle tool to clear area.

Never move your shredder-chipper or leave it unattended with the engine running.

OPERATE IN SAFE ENVIRONMENT

Never operate your shredder-chipper on slippery, wet, muddy, or icy surfaces. Safe footing is essential in preventing accidents.

Only operate on level ground.

Keep work area clean and clear of debris so that you don't stumble over it.

REPAIR AND MAINTENANCE SAFETY

Never operate your shredder-chipper in poor mechanical condition or when in need of repair. Periodically check that all nuts, bolts, screws, and belts are tightened. Be sure all safety guards and shields are in the proper position. These safety devices are for your protection.

Don't service or repair your shredder-chipper without removing the spark plug wire.

Replace old, damaged or worn parts such as bolts or guards immediately.

Follow engine owners manual for engine maintenance and repair.

OPERATION

Whenever you operate your shredder-chipper, wearing gloves and safety glasses is required. If necessary to push material into shredding chamber, use a wood stick, never hands or steel implements. At the end of this section we offer additional cautions. Read and observe them.

As the engine ignition begins, the engine operates under no load until approximately 1200-1400 rpm at which speed the centrifugal clutch engages and begins driving the rotor. Proper rotor speed is in the 2500 rpm range with a plus or minus tolerance of 200 rpm. At this speed you have four rows of hammers literally cutting or beating material until it is small enough to pass through the 1" screen. The 1" screen retains the material within the grinding chamber long enough for the free-swinging hammers to do their job. The number of cuts by the hammers retention time within the chamber varies with each organic material and the size of the opening in the screen.

The discharge end of the shredder body has two drilled holes in each side through which passes a baffle rod. The loose end of the plate rests over this rod providing you with two angles of discharge. Adjust the baffle plate (item 21, page 18) to direct the discharge down and away from the shredder. If ever you shred or compost without the perforated screen, be certain the baffle plate is held away from the rotor by its baffle rod (item 31, page 14) at the center hole of the discharge. If not, the baffle plate will swing backward into the grinding chamber striking the rotor hammers. Damage will result.

When viewed from the pulley side of the shredder body, the rotor runs counterclockwise. This action tends to pull materials into the shredding chamber. Short stalks (bean plants), cobs, sod and similar materials should be fed into the hopper by a garden spade or pitchfork. Long stalks like corn or trimmings can best be fed by hand slowly to avoid having the rotor pull in the complete stalk, wrap it and stall. When feeding stalks or trimmings by hand, be certain to keep your hands away from the rotor and hammers. Remember that a technique and understanding is required to successfully shred or grind the great variety of materials which may be available to you for compost. Do not put any sticks or limbs over 1" in diameter down the shredding hopper.

Branches are fed into the side hopper for chipping. One at a time, if they are thicker than 2" in diameter, several together if of a smaller diameter. Since the throat opening is approximately 3" square, some side shoots or side branches may have to be trimmed from the main stalk before chipping. Short stubs of branches should be pushed through the chipper section with the next branch. Never assume you know where the blade is, and try to push branches in by hand. You don't know where it is. Be safe, keep your hands away from the chipping blade.

- (1) Lubricate the chipper side rotor bearing before operating and after every 10 hours of operation with lithium base grease that is suitable for ball bearings. The belt side bearing is self-lubricating and does not require greasing. Also check the bearing collar set screws regularly to be sure they are tight. If they are loose reset them with EV grade Loc-tite or equivalent obtainable at any hardware store.
- (2) Do not allow an accumulation of processed material to build up under the discharge of the shredder-chipper-grinder as this can prevent following shredded material to discharge and will result in clogging. Use a long handled stick or spade to remove processed material build-up. **DO NOT USE YOUR HAND OR FOOT.** Always shut the unit off before clearing build-up.
- (3) Never allow your hands or any part of your body or clothing inside the feed hopper or discharge area of the shredder-chipper. Use a wood stick to push material down the hopper.
- (4) Keep all protective guards on the machine and deflectors in place and in good working condition.
- (5) Always stand clear of the discharge area when the shredder is running.
- (6) Keep your face and body back from the feed hipper to avoid being struck by any material that may bounce back. Do not overreach, keep proper balance and footing.
- (7) Do not transport the shredder while the engine is running.
- (8) Do not refuel the engine while it is hot, warm, or running.
- (9) Do not cover the shredder while the muffler is still hot.

MAINTENANCE AND STORAGE:

If the cutting mechanism strikes any foreign object or if your machine should start making an unusual noise or is vibrating, stop the engine, disconnect the spark plug wire from the spark plug. Allow the engine to cool before you:

- (a) Inspect for obvious damage
 - (b) Check for loose parts, bolts, rods, broken hammers or spacers. Examine rotor visually for any obvious defects.
- (1) When not in use, your machine should be stored out of the reach of children. Be sure there are no gasoline fumes in the storage area. For long periods of storage (over winter), gasoline should be drained from the tank or add a gas stabilizer (ie. STABIL). Always allow the engine to cool before storing, or covering.
 - (2) When the hard steel hammers become dull or round on the cutting or leading edge, they may be reversed. First remove the belt guard (item 71) by removing the bolts, nuts, etc., as shown on the main assembly drawing. You will notice that when the belt guard is removed, there is a round cover plate (item 86) which

when removed will give you access to the hammer rods (part no. 40797). One hammer rod at a time can be removed through this side hole and the hammers reversed as the rotor is reassembled. Each rod is held in place by a grooved pin. (See page 12 for information on removal and reinstallation of the pin). Install new pins. Extreme care must be taken to reinstall the spacers (items 12, 13 and 14) in exactly the same order as shown on the drawing. We emphasize this point. The spacers and hammers must be reinstalled in exactly their original order (see drawing 803-000-1).

- (3) You will find included information referring to operation and maintenance of the shredder engine. Look it over carefully. **BE CERTAIN TO PUT OIL IN THE ENGINE BEFORE YOU START IT.**
- (4) When the steel chipping knife (item 6, page 16) needs replacing or sharpening, rotate the chipper disc until the three countersunk screws holding the blade are behind the access panel. When you install the knife **be certain** to use E.V. grade Loc-tite on the threads so they will not come loose.
- (5) Care must be exercised when sharpening the blade to maintain the correct bevel and a straight cutting edge. When you install a knife, the clearance between knife and wear plate (item 7, page 16) must be checked. This clearance or gap should be minimum $3/64$ ", maximum $1/16$ ". See figure 3, below. To adjust this clearance, loosen the three $1/4$ " flathead bolts which are located on the outside of the chipper wear plate next to the chipper side plate. Move the wear plate in or out as necessary and tighten the $1/4$ " nuts securely.
- (6) Note:, if the gap between wear plate and knife is excessive, you will have vibration when chipping and the blade will seem to be dull.
- (7) If at any time it becomes necessary to disassemble the chipper for repairs, the chipping disc (item 5, page 16) must be installed in **exactly** its correct position on the shaft.
- (8) See page 9 for installation and servicing instructions on the centrifugal clutch.

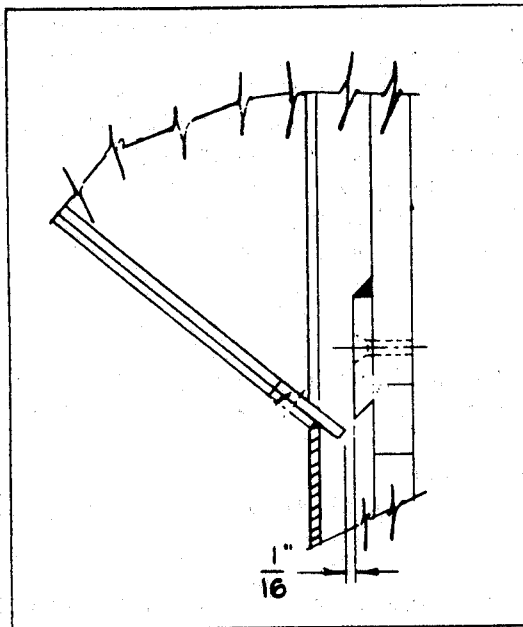
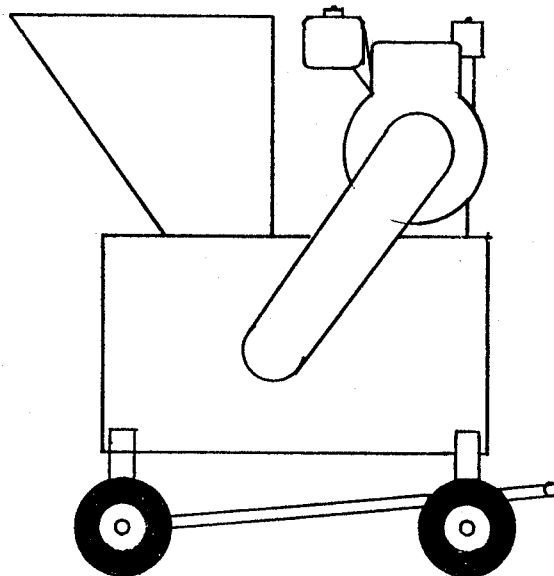

FIGURE 3

Your Snapper SG 8000 shredder-chipper has been carefully assembled at the factory and is nearly ready for your use. However, there are a few things you must do prior to using the machine.

1. Be sure to put oil in the engine crank case. Refer to the enclosed engine instruction manual for proper weight oil. If you start the engine and run it without oil, major damage will result.
2. Add clean gasoline to the engine. Again, check the engine instruction manual for details.
3. Grease the bearing on the chipper side only. Locate the grease fitting and use a grease gun and lithium base grease. Do not over grease, just a small amount is necessary.
4. With the engine in the stop position and the spark plug wire removed, open the shredder hopper and reach in and spin the rotor. The rotor and hammers should turn freely with no obstruction. If it does not turn freely, determine what the obstruction is and remove it.
5. With the engine in the stop position and the spark plug wire removed, raise the discharge baffle plate, and make sure the standard 1" screen is in place.
6. Check the tightness of the belt, see figure 1 and 2 below for proper tension. If the belt needs adjusting, loosen the four bolts that hold the engine to the engine mounting plate and tighten or loosen the belt tensioner nut (item 58, page 18). When proper tension has been achieved, tighten engine mounting bolts securely.
7. Be sure to install the chipper hopper (item 18, page 16) to the chipper chute. This is easily done by loosening the hopper locking handle (item 27, page 16), raise the protective cover, slip the pins on the chipper hopper into the slots on the chipper chute. Rotate the hopper down so that the handle will lock it in position.



For convenient storage of your unit the tow bar can be rotated and placed on the rear axle. See drawing above.

SHREDDING TIPS (TECHNIQUE):

- (1) Before you start shredding or chipping, check the shredding chamber to be sure that it is clear of any and all debris.
- (2) Generally you can apply these rules: When material being processed is dry, brittle, hard or woody, use the standard 1" perforated screen in the shredder. For wet, soggy materials, the unit will shred better without a screen. An optional bar screen can be used to advantage when shredding green fibrous materials such as cornstalks, wet straw or manure. After processing wet or soggy materials, the shredding chamber can be cleaned quickly by reinstalling the 1" screen and grinding a few branches or wood chips.
- (3) The optional screens with 1/4", 1/2", or 3/4" perforations are for special purpose (potting soil, grinding shell fish residue such as clam shells). First process the material through the 1" screen then through the smaller hole screen. This works very well on grains for poultry feed.
- (4) When grinding green or damp material (cornstalks, potato vines, tomato vines, green or fresh pulled plants), remove the 1" screen and either install a bar screen or use no screen at all. Direct the shredder to discharge into a compost pile or against a wall, large board or other obstruction. Feed cornstalks by hand, slowly, several at a time until the last 18" remain in your hand - then let go. This will give you a coarsely shredded product several inches long. With a garden spade or pitchfork refeed this material into the shredder until it reaches the consistency you want. A cornstalk that has been processed this way, just one time, will chemically break down within a day or two in your compost heap. For green materials such as tomato or potato vines, you may first have to snap off extending side shoots. Place vine in the hopper and prod further with a rugged stick (never your hands).
- (5) For grinding dry leaves, use the 1" perforated screen and dump leaves into the top feed hopper by the basket, bag, or pitchfork. If bridging occurs, use a stick to stir leaves into the shredding chamber. Freshly fallen leaves do present a problem, and it is best to pile these and allow to sit until they become quite soggy. If this is impractical, these wet or damp leaves must be processed through the unit with no screen and along with other materials. All by themselves, for the most part, wet leaves will simply blow through the shredder. Soggy, partly decomposed leaves process very well. Again, remove the screen. Dump in pitchfork loads and prod through with a stick.

Use common sense when using your shredder-chipper. Learn to recognize the change in sound when it is overloaded. If the rotor becomes jammed by overloading or another cause, stop the engine immediately and no damage will occur. **IF YOU JAM THE ROTOR AND DO NOT STOP THE ENGINE IT WILL BURN THE BELT OR RUIN THE CLUTCH.**

To free a jammed rotor, stop the engine, remove the spark plug wire, remove the screen and remove the material left in the shredding chamber. Check to see that the rotor will turn freely before you start the shredder.

- (6) For green hedge prunings, small diameter wood prunings (with leaves), rose or flower trimmings, process with the 1" perforated screen installed. Feed bunches at a time through the top feed hopper. Experience will tell you how much your unit can handle at one time.
- (7) To process branches, dry or green, use the side chipping hopper.; The 1" screen may be left installed but it serves no practical purpose when chipping. It is best to clip off side twigs or limbs from the main branch. Feed one at a time if they are 2" or more in diameter. Green branches process more quickly and easier than dry branches and of course soft wood easier than hard wood. Push the branch in at an angle of the hopper and throat. Always use the hopper extension. Never allow your hands to enter the hopper. As the branch being chipped gets shorter, finish chipping the stub by shoving in with the next branch to be chipped. Never throw the stub into the shredder hopper. It is too large to be processed through the shredder and will damage the machine.

Only your operator experience will tell you when to use a screen or no screen, how fast to feed and how to process difficult materials. There is such a magnitude of possible materials that we cannot discuss each individually. Some naturally are easier to work with than others, but most all common organic products available to a gardener can be processed by using your unit and common sense.

CENTRIFUGAL CLUTCH INSTALLATION AND SERVICING INSTRUCTIONS FOR 1" CLUTCH NO. 40783

INSTALLATION

- (1) Clean shaft and remove any burrs.
- (2) Place key in keyway inside clutch hub.
- (3) Slide clutch onto shaft, followed by washer if required.
- (4) Lock clutch to shaft with set screws.

LUBRICATION AND MAINTENANCE

The centrifugal clutch on this machine is permanently lubricated and does not require oil or grease. If, after long periods of use, the drum wobbles excessively, replace the bushing. Replace damaged set screws. Always replace shoes and springs in pairs; whenever shoes are changed, replace both springs.

REMOVAL AND DISASSEMBLY

- (1) Remove clutch from shaft by loosening set screws. Remove key from keyway.
- (2) Remove retainer ring and slide off drum assembly.
- (3) Release one hook of spring from shoe pin.
- (4) Carefully note position of shoes. Remove shoes from hub.

REASSEMBLY

- (1) Locate shoes correctly on hub for rotation required.
- (2) Place one end of each spring over a shoe pin, stretch spring just enough to clear pin on the other shoe. Avoid overstretching that may damage spring.
- (3) Replace fiber washer on hub shaft.
- (4) Reassemble drum to hub, secure with retaining ring.
- (5) Locate key in keyway of hub.
- (6) Slide clutch onto crankshaft, then spacer(s) or washer.
- (7) Secure hub by tightening set screws.

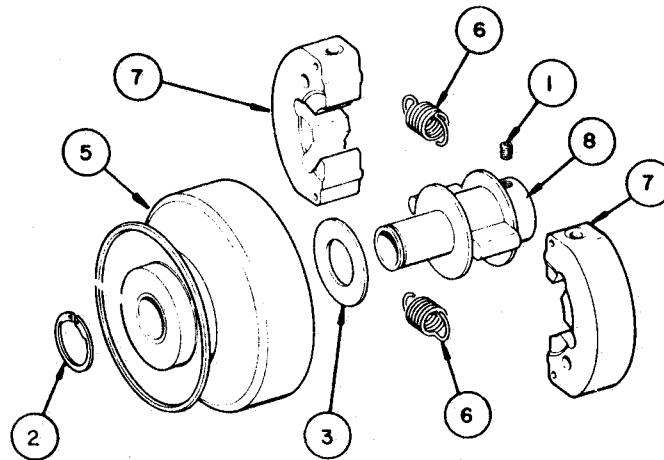

**CLUTCH PARTS LIST, 1" BORE - 8 HP ENGINES
Complete Part #40783**

Key No.	Part No.	Description	Quantity
1	40790	Set Screw	2
2	40791	Retaining Ring	1
3	40792	Washer	1
5	40793	Drum & Bushing	2
6	40794	Spring	2
7	40795	Shoe	2
8	40796	Hub	1

TROUBLE SHOOTING - QUESTIONS & ANSWERS:

- (1) ***My machine stalls as soon as I put anything in it.***
This could be a problem of a slow engine or loose belt. When you say it stalls, do you mean the engine or the rotor or both? If the rotor stops but the engine keeps running, you may have a loose belt, slipping clutch or some of each. If the engine stalls, it can be a carburetor problem or it is running too slow. These engines should run at top speed of 3600 rpm (factory set by Briggs & Stratton). The rotor pulley should be driving at 2500 rpm with a plus or minus tolerance of 200 rpm.
- (2) ***My machine vibrates too much.***
First, you should never run your shredder-chipper on a concrete or blacktop surface. Always have it resting on sod or soft earth. Vibration can come from poor engine ignition, an unbalanced rotor or a vibrating engine. Visually check the rotor to be certain all hammers and spacers are still intact and wearing evenly. Remove the drive belt and start the engine. If vibration is unchanged, then you have an engine problem. Discuss this with an authorized Briggs & Stratton dealer or repair shop.
- (3) ***My shredder-chipper worked fine last year but now I can't chop anything.***
This is probably due to excessive wear on the hammers. If you have processed sand, soil or phosphate rock, your hammer tips will round off and wear away. Paragraph 2, page 5 (maintenance and storage) discusses replacement or reversing the hammers.
- (4) ***My centrifugal clutch smokes and burns the belt.***
In all probability the inner shoes of the clutch are worn or the retaining springs are weak or broken. A view of the clutch is given on page 9. You may also have a loose drive belt. If you attempt starting your shredder with heavy material in the grinding chamber, the rotor may refuse to turn when the engine comes up to rpm, thus burning the clutch. Check the shredding chamber for cleanliness.
- (5) ***My rotor pulley comes loose and falls off.***
The pulleys are formed steel and the shafts machined 1-3/16" steel. The pulley hub has two set screws, one directly over a key. Be certain the key is still in place. In all probability it is not. Apply E.V. grade Loctite to each set screw and tighten down hard. Be certain the rotor pulley lines up with the drive pulley to prevent undue belt wear and to prevent the belt from rolling over or slipping off.
- (6) ***My chipping knife is dull after only an hour.***
Unless you accidentally put metal or dirt in the chipping hopper, the clearance between the knife and wear plate has changed. This causes the knife to take too big a bite and gives the impression of dullness or creates excessive vibration on your hands when using the chipper. Paragraph 5, page 6 discusses knife to wear plate clearance (1/16"). Adjust this by moving the wear plate in. If the knife setting is too narrow, mostly sawdust and slow chipping will result.

RIGHT WAY

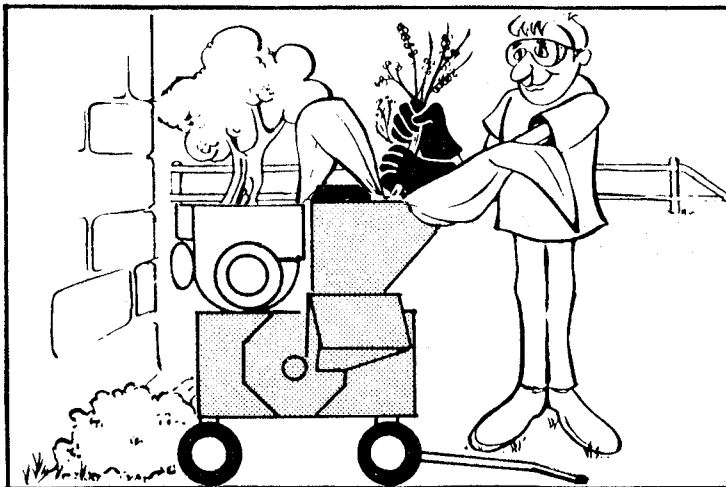

Do stand back - wear glasses and gloves

WRONG WAY

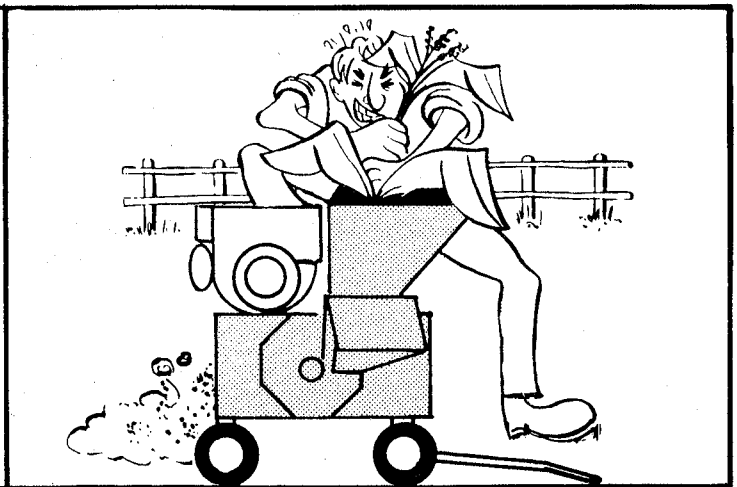

Don't allow hands to enter hopper or peer into hopper with face.

RIGHT WAY

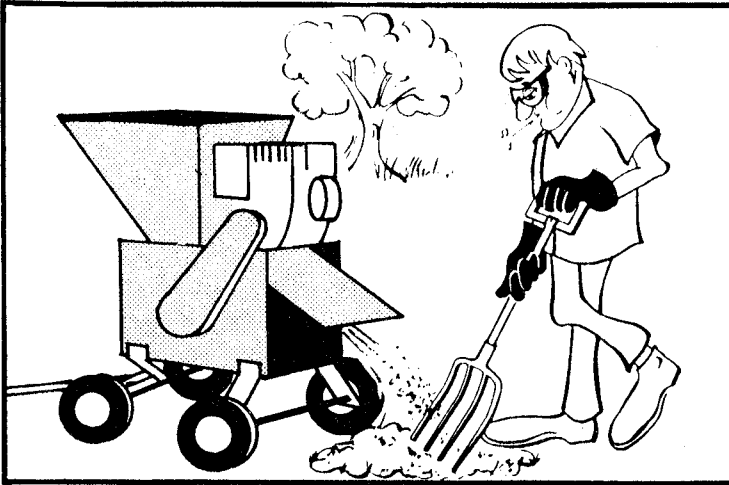

Do clear discharge area of machine with spade, rake or long handle tool.

WRONG WAY

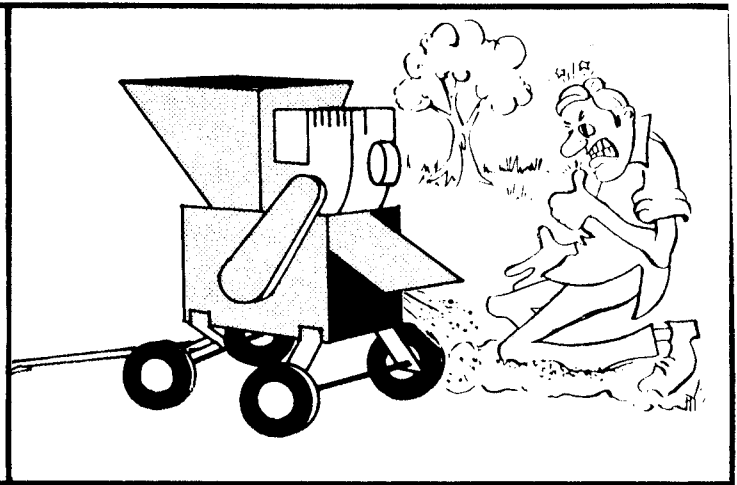

Don't clear discharge with hands. Never place any part of your body in discharge area.

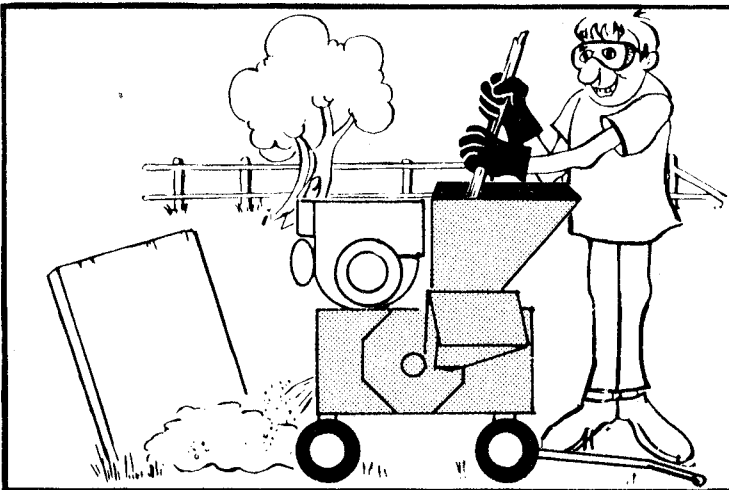

Use stick, never hands, if material bridges in hopper. Do keep people away and discharge shredded material into compost heap or fixed known obstruction.

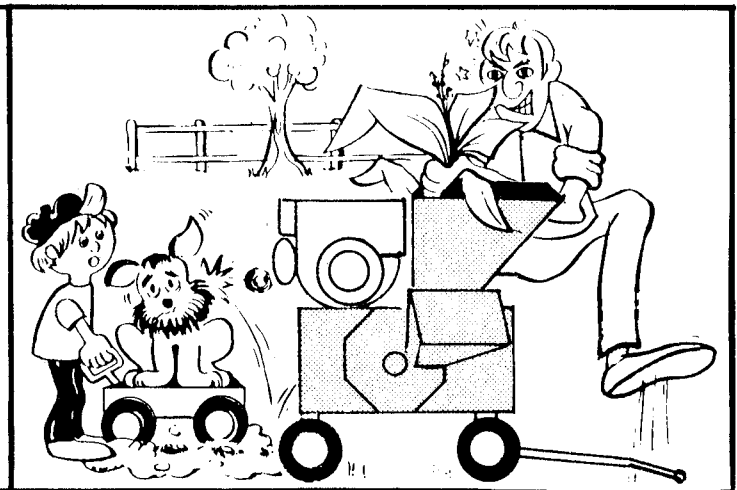

Don't allow pets, children or bystanders in operating area.

REMOVAL AND RE-INSTALLATION OF GROOVE PINS

- (1) Remove hopper. (Item #17)
- (2) Turn rotor until hammer rod (Item #10) is facing up — See sketch below.
- (3) Turn hammer rod (Item #10) until small end of groove pin (Item #15) is facing up.
- (4) Use a 3/16 Dia. punch and drive groove pin out of hammer rod.
- (5) When installing groove pin be sure you put the end without groove in hole first, then drive pin in to hammer rod until it stops.
- (6) Re-install hopper.

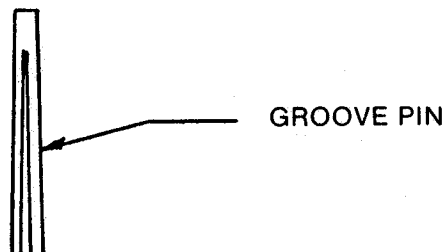
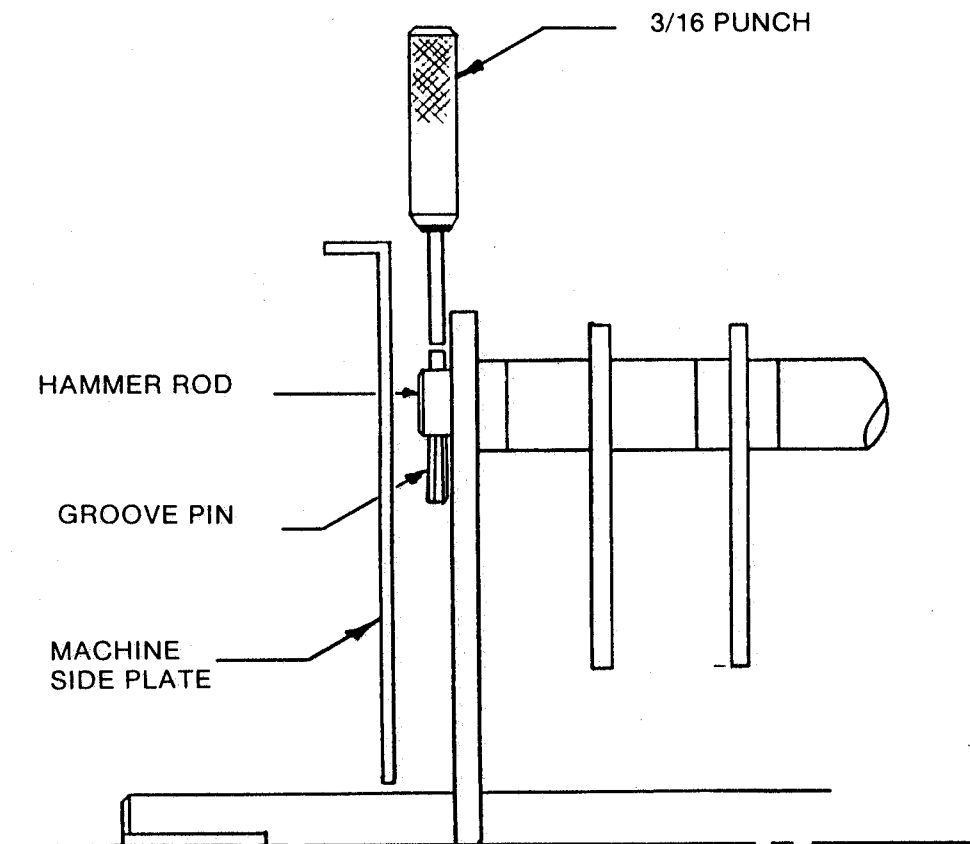

REPLACE OF HOPPER WITH VIBRATION DAMPENERS

- (1) Take the hopper (item 17) and push the vibration dampeners up into the holes, see drawing 803-0000 page 18 and Figure A below.
- (2) Place the hopper with the vibration dampeners on the unit. NOTE: the straight side of the hopper is next to the engine. Align the holes of the side plates with the hopper.
- (3) With the 5/16-18 x 1-1/4 bolts (item 39) thread the bolt up through the shredder side plate and into the vibration dampener.
- (4) Continue to tighten the bolt until the distance from the top of the vibration dampener to the top surface of the hopper angle is 5/8" (See Figure A below). DO NOT OVERTIGHTEN.

FIGURE A

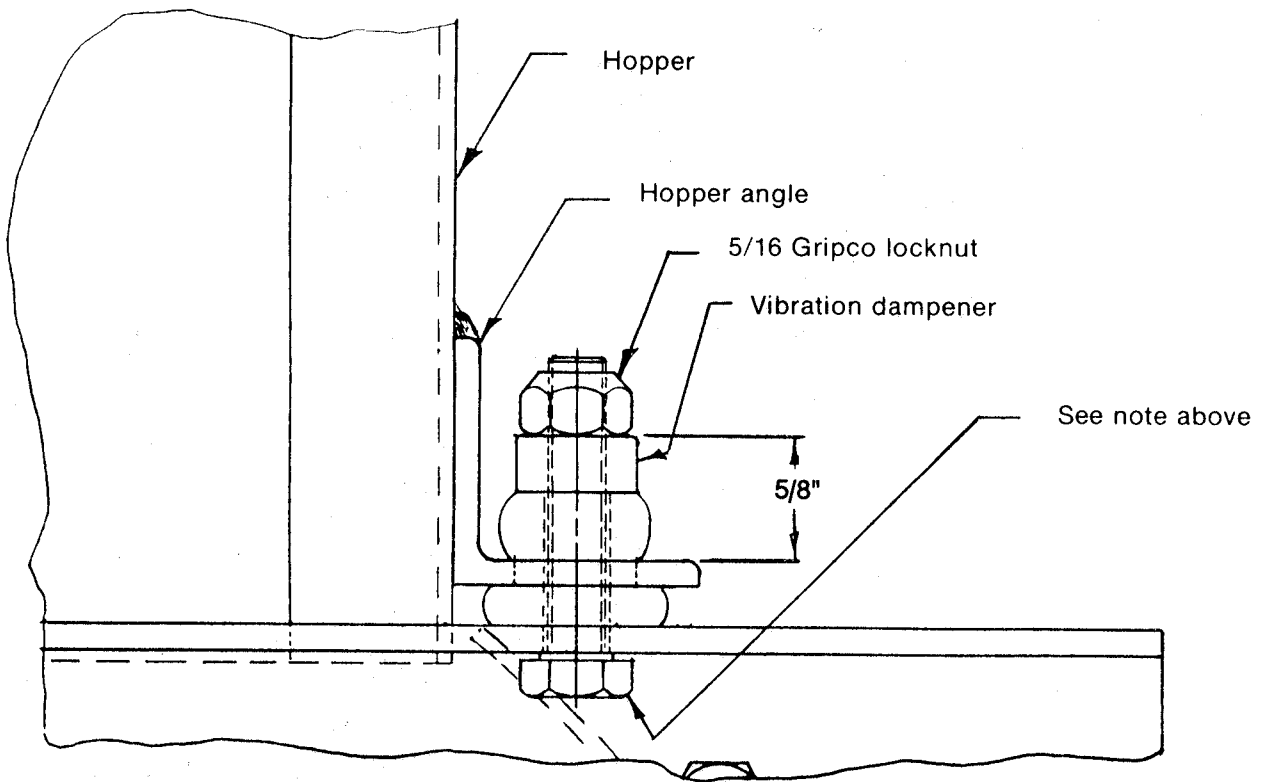

**BASIC SG 8000 SHREDDER-GRINDER
PARTS LIST PER DRAWING 803-0001**

Item No.	Part No.	Description	Quantity
1	40753	Right Side Plate	1
2	40754	Left Side Plate	1
3	40755	Scroll	1
9	40756	Rotor Weldment	1
10	40797	Hammer Rod	4
11	40802	Hammer	24
12	40803	Spacer 7/8"	20
13	40804	Spacer 5/8"	4
14	40805	Spacer 5/16"	4
15	40806	Groove Pin	4
19	40757	Top Plate	1
20	40758	Screen (1" Standard)	1
31	40759	Screen and Baffle Rod	2
32	40760	Tie Rod	1
33	40761	Bearing Right Side	1
35	40855	3/8-16 x 1 Hex Hd. Cap Screw GR 5 Blk.	2
37	90449	3/8-16 Grip-Co Lock Nut Blk.	2
39	90636	5/16-18 x 1-1/4 Hex Hd. Cap Screw GR5 Blk.	6
41	76934	5/16-18 x 3/4 Hex Hd. Cap Screw GR 5 Blk.	4
42	90194	5/16-18 Grip-Co Lock Nut Blk.	11
53	11773	3/32 Hair Cotter Pin	2

1-7629 (R 8/95)

DATE	BY	REVISION	RECORD

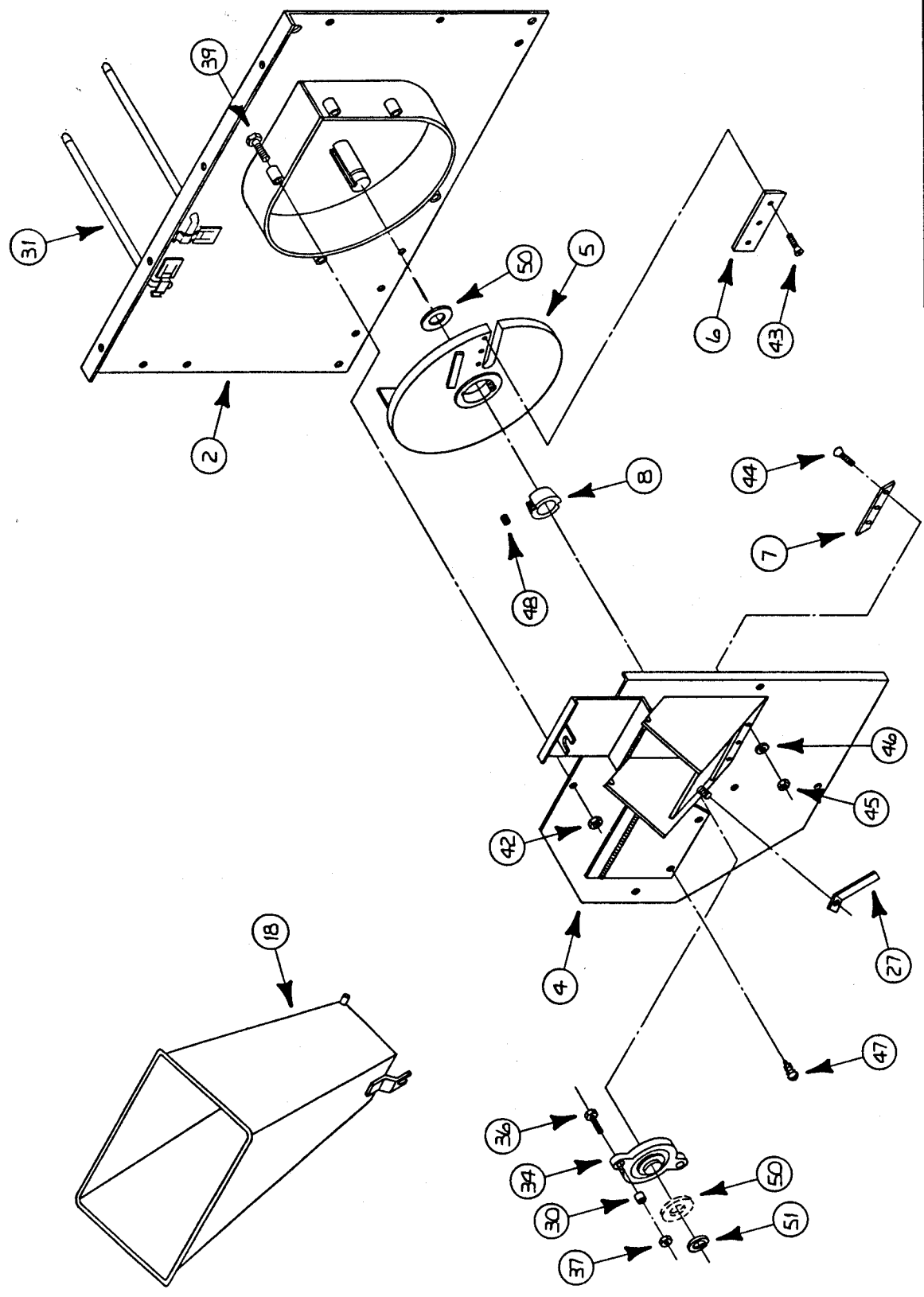

TOLERANCES UNLESS AS NOTED:	AMERIND - BACKISSIO INC., PARKER FORD, PA 19457	
DRAWN BY	SCALE	APPROVED BY
SG 8000	---	J.P. [Signature]
TITLE	BASIC CHIPPER	
DATE	DRAWING NUMBER	C-803-0000-2
7-14-55		

ITEM 50 MAY BE LOCATED EITHER PLACE AT FACTORY ASSEMBLY.

**BASIC SG 8000 SHREDDER-GRINDER
PARTS LIST PER DRAWING 40752**

Item No.	Part No.	Description	Quantity
1	40754	Left Side Plate	1
4	40762	Chipper Side Plate	1
5	40763	Chipper Disc	1
6	40809	Knife	1
7	40764	Wear Plate	1
8	40765	Bushing 1-3/16	1
18	40767	Chipper Hopper	1
27	40768	Hopper Locking Handle	1
30	40769	Bushing	2
31	40778	Screen and Baffle Rod	2
34	40771	Bearing Left Side	1
36	40855	3/8-16 x 1 Hex Hd. Cap Screw GR 5 Blk.	2
37	90449	3/8-16 Grip-Co Lock Nut Blk.	2
39	90636	5/16-18 x 1-1/4 Hex Hd. Cap Screw GR 5 Blk.	5
42	90194	5/16-18 Grip-Co Lock Nut Blk.	5
43	40867	5/16-18 x 3/4 Flat Hd. Socket Cap Screw Blk.	3
44	40856	1/4-20 x 1 Flat Hd. Socket Cap Screw Blk.	3
45	40853	1/4-20 Flex Lock Nut	3
46	90598	1/4 Flatwasher	3
47	40857	6-32 x 3/8 Sheet Metal Screw	2
48	40858	3/8-16 x 5/8 Set Screw	2
50	40859	1-3/16 Flatwasher	2
51	40860	Retaining Ring	3

1-7628 (IR 895)

**SG8000 SHREDDER-GRINDER
PARTS LIST PER DRAWING 803-0000**

Item No.	Part No.	Description	Quantity
16	40772	Spacer	1
17	40773	Hopper	1
21	40774	Baffle Plate	1
22	40775	Front Axle Mounting Bracket	1
23	40776	Axle	2
24	40777	Axle Bracket	2
25	40778	Tow Hitch	1
26	40779	Pull Handle	1
28	40780	Belt Tensioner	1
29	40781	Hopper Flex Guard	1
38	40782	Tie Rod	1
39	90636	5/16-18 x 1-1/4 Hex Hd. Cap Screw GR 5 Blk.	4
52	40801	Push Button	3
54	40799	Vibration Dampner	4
55	90669	5/16-18 x 1-3/4 Hex Hd. Cap Screw Pltd.	4
56	90194	5/16-18 Grip-Co Lock Nut Pltd.	7
57	90692	5/16 Flat Washer Pltd.	8
58	40861	5/16-18 Flex Lock Nut Pltd.	1
59	76934	5/16-18 x 3/4 Hex Hd. Cap Screw Pltd.	2
60	40862	3/8-16 x 3/4 Hex Hd. Cap Screw Pltd.	4
61	90449	3/8-16 Grip-Co Lock Nut Pltd.	4
62	90655	3/8-16 x 1-1/2 Hex Hd. Cap Screw Pltd.	1
63	90600	3/8 Flatwasher Pltd.	2
64	40863	3/8-16 Flex Lock Nut Pltd.	1
65	40873	Handle Grip	2
66	90042	1/8 x 1-1/4 Cotter Pin	4
67	40864	5/8 Flatwasher Pltd.	5
68	40788	Axle Spacer	2
69	40865	5/8-11 Hex Nut Pltd.	2
71	40798	Belt Guard	1
72	40783	Clutch	1
73	77681	1/4-28 x 1/4 Set Screw	2
75	40789	Rotor Pulley	1
76	90201	5/16-18 x 5/16 Set Screw	2
77	13250	1/4 x 1/4 x 1 Shaft Key	2
78	40784	Belt 4L-450	1
79	40785	Wheel 10.5 x 3.50	4
80	40786	Engine 8 HP	1
86	40808	Cover Plate	1
87	40866	5/16-18 Kep Nut	1
88	76934	5/16-18 x 5/8 Hex Hd. Cap Screw	1
89	40787	Axle Rod	1
90	40752	Basic Shredder-Grinder	1

MANUFACTURER'S 2 YEAR LIMITED WARRANTY

For two (2) Years from purchase date for the original purchaser's residential, non-commercial use [ninety (90) days from purchase date for the original purchaser's commercial, rental, or other non-residential use], SNAPPER POWER EQUIPMENT, through any SNAPPER dealer will replace, free of charge, any part or parts found upon examination by the factory at McDonough, Georgia, to be defective in material or workmanship or both.

All transportation cost incurred by the purchaser in submitting material to a SNAPPER dealer for replacement under this warranty must be borne by the purchaser.

This warranty does not apply to engines and their components, as these items are warranted separately by their manufacturers. This warranty does not apply to parts that have been damaged by accident, alteration, abuse, improper lubrication, normal wear, or other cause beyond our control.

There is no other express warranty.

Implied warranties, including those of merchantability and fitness for a particular purpose, are limited to two (2) years from purchase date for the original purchaser's residential, non-commercial use [ninety (90) days from purchase for the original purchaser's commercial, rental or other non-residential use], and to the extent permitted by law any and all implied warranties are excluded. This is the exclusive remedy. Liabilities for consequential damages, under any and all warranties are excluded.

Some states do not allow limitations on how long an implied warranty lasts, or do not allow the exclusion or limitation of incidental or consequential damages, so the above limitation or exclusion may not apply to you.

This warranty gives you specific legal rights, and you may also have other rights which vary from state to state.

WARNING: THE USE OF REPLACEMENT PARTS OTHER THAN GENUINE SNAPPER PARTS MAY IMPAIR THE SAFETY OF SNAPPER PRODUCTS AND WILL VOID ANY LIABILITY AND WARRANTY BY SNAPPER ASSOCIATED WITH THE USE OF SUCH PARTS.

IMPORTANT: Please fill out the attached SNAPPER Product Registration Card immediately and mail to: SNAPPER POWER EQUIPMENT, McDONOUGH, GEORGIA 30253

SNAPPER® McDonough, GA., 30253 U.S.A.