



3500 Pelco Way,  
Clovis, CA 93612-5699  
USA

In North America & Canada:  
Tel (800) 289-9100  
FAX (800) 289-9150

International Customers:  
Tel +1 (559) 292-1981  
FAX +1 (559) 348-1120

[www.pelco.com](http://www.pelco.com)

## **C401M-C (12/99) EH1000 Ceiling Enclosure**

### **IMPORTANT SAFEGUARDS AND WARNINGS**

Prior to installation and use of this product, the following WARNINGS should be observed.

1. Installation and servicing should only be done by qualified service personnel and conform to all local codes.
2. Unless the unit is specifically marked as a NEMA Type 3, 3R, 3S, 4, 4X, 6 or 6P enclosure, it is designed for indoor use only and it must not be installed where exposed to rain and moisture.
3. Only use replacement parts recommended by Pelco.

The product and/or manual may bear the following marks:



This symbol indicates that dangerous voltage constituting a risk of electric shock is present within this unit.



This symbol indicates that there are important operating and maintenance instructions in the literature accompanying this unit.



Please thoroughly familiarize yourself with the information in this manual prior to installation and operation.

### **DESCRIPTION**

The EH1000 low-profile ceiling enclosure for 2/3-inch format cameras is designed to be mounted in fixed or dropped ceilings. The upper section mounted above the ceiling is constructed of aluminum to meet most fire code requirements for installation in open plenum ceilings.

The EH1000 is engineered for ease of installation and service. The lower section is hinged to provide convenient access for adjusting camera and lens. The upper section has generous interior dimensions which allow additional camera angle adjustments to be made.

The EH1000 is equipped with a tamper-resistant lock for security protection. Cable entry is through conduit knockouts.

### **INSTALLATION**

To mount the EH1000 directly into a fixed or dropped ceiling, perform the following steps:

1. Determine the location and direction of the enclosure to be mounted. Ideally, the enclosure cutout should be parallel and adjacent, or perpendicular, to any ceiling structure. Avoid cutting into any ceiling structural members.
2. Open the cover of the enclosure to expose the mounting holes in the flange.
3. Remove any appropriate knockouts.
4. Insert the enclosure into the opening and secure with the appropriate fasteners.
5. Mount the camera and lens onto the adjustable mounting bracket. Adjust the position of the camera and lens to clear the enclosure cover when closed. Tighten the mounting bracket fasteners.
6. Route the appropriate cables into the enclosure. Make all necessary electrical connections.
7. Close and lock the cover.

**NOTE:** *The camera mounting bracket is reversible, to accommodate various camera and lens combinations.*

**NOTE:** The instructions provided are for installation in a 2' x 2' ceiling tile. If mounting in a 2' x 4' ceiling tile, you will need to cut the ceiling tile in half and install an additional "T" rail for support.



**CAUTION:** Do not use water, liquid or spray cleaners of any kind on inner surface of the enclosure.

### **Installation Using E1003 Mounting Plate**

To install the EH1000 Ceiling Enclosure in dropped or false ceilings utilizing the E1003 Mounting Plate, perform the following steps. Refer to Figure 1.

The E1003 is supplied as follows:

<u>Quantity</u>	<u>Description</u>
1	Plate, square
1	Plate, round
8	Spacers
8	Screws, 10-32 x 1-inch

1. Place the E1003 (square and round plates, items 1 and 2) on a flat surface with the painted surface up.
2. Open the lid of the enclosure (EH1000) and insert the enclosure into the rectangular opening.
3. Position the spacers (item 3) provided between the mounting flange of the enclosure and the round plate of the E1003, aligning them with the eight mounting holes.
4. Secure the enclosure to the E1003 with the screws (item 4) provided, making sure the screws pass through the spacers. Tighten the hardware.
5. Mount the enclosure into the 2 ft x 2 ft opening in the ceiling.
6. Refer to steps 3, 5, 6, and 7 in the previous section for final installation instructions.

### **CARE AND MAINTENANCE**

Regularly scheduled maintenance will prolong the operational life and appearance of the equipment.

1. If dust or other debris accumulates on the inside of the lower enclosure, remove the particles with clean air pressure only. Compressed air cans are available from commercial photographic equipment and supply dealers.
2. Clean the outer surface of the enclosure and the inner surface of the viewing window with a non-abrasive cleaning cloth and anti-static cleaner that is safe for use on acrylic plastic. Do not use kerosene or similar substances that can scratch the surface.

### **SPECIFICATIONS**

#### **MECHANICAL**

Camera Mounting: Adjustable bracket; supports a 10-pound (4.5 kg) maximum load

Max.

Camera/Lens Size: Accepts camera/lens combinations up to 4.5" H x 15.0" L x 6.5" W  
(11.43 x 38.10 x 16.51 cm)

Ceiling Mounting: Upper section flange-mounted to fixed ceiling or E1003 rotating mounting plate for false ceilings

Viewing Window: Lucite® SAR (Super Abrasion Resistant Acrylic)

Cable Entry: Conduit knockouts

Lock: Key lock

#### **GENERAL**

Certification: UL listed, NEMA Type 1 enclosure suitable for plenum use

Construction: Upper section, 5052-H32 aluminum  
Lower section, vacuum-formed ABS plastic

Color: Upper section, alodine  
Lower section, white textured

Dimensions: See Figure 2

Weight: 5 lb (2.268 kg)

*(Design and product specifications subject to change without notice.)*

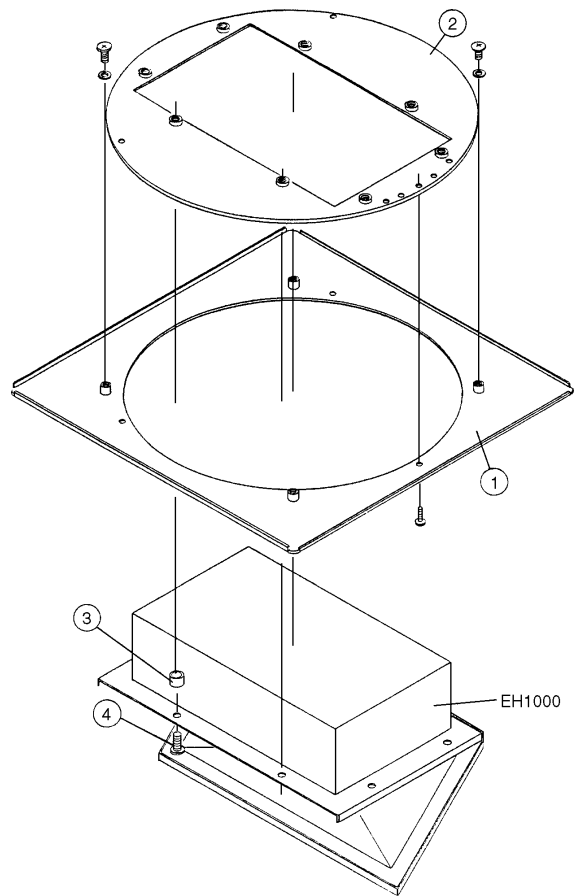

**Figure 1. E1003 Ceiling Mounting Plate Installation**

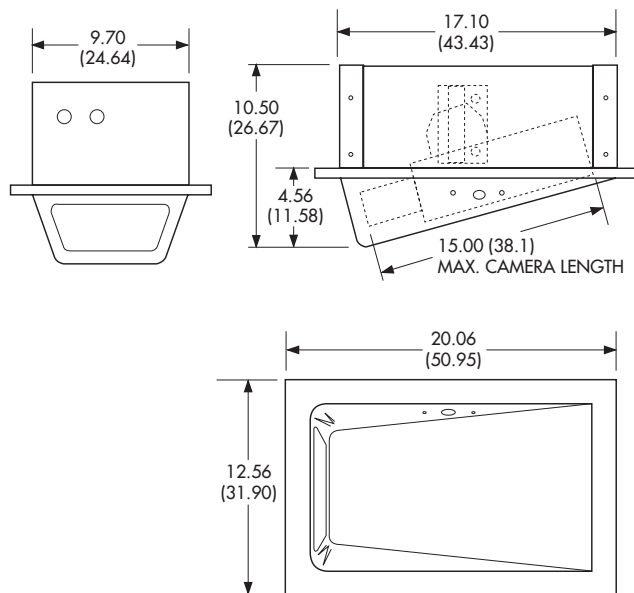

NOTE: VALUES IN PARENTHESES ARE CENTIMETERS;  
ALL OTHERS ARE IN INCHES.

**Figure 2. EH1000 Dimensions**

## WARRANTY AND RETURN INFORMATION

### WARRANTY

Pelco will repair or replace, without charge, any merchandise proved defective in material or workmanship for a period of one year after the date of shipment.

Exceptions to this warranty are as noted below:

- Five years on FT/FR8000 Series fiber optic products.
- Three years on Genex® Series products (multiplexers, server, and keyboard).
- Three years on Camclosure® and fixed camera models, except the CC3701H-2, CC3701H-2X, CC3751H-2, CC3651H-2X, MC3651H-2, and MC3651H-2X camera models, which have a five-year warranty.
- Two years on standard motorized or fixed focal length lenses.
- Two years on Legacy®, CM6700/CM6800/CM9700 Series matrix, and DF5/DF8 Series fixed dome products.
- Two years on Spectra®, Esprit®, ExSite™, and PS20 scanners, including when used in continuous motion applications.
- Two years on Esprit® and WW5700 Series window wiper (excluding wiper blades).
- Eighteen months on DX Series digital video recorders, NVR300 Series network video recorders, and Endura™ Series distributed network-based video products.
- Six months on DX Series digital video recorders, NVR300 Series network video recorders, Endura™ Series distributed network-based video products, and TW3000 Series twisted pair transmission products.
- One year (except video heads) on video cassette recorders (VCRs). Video heads will be covered for a period of six months.
- Six months on all pan and tilts, scanners or preset lenses used in continuous motion applications (that is, preset scan, tour and auto scan modes).

Pelco will warrant all replacement parts and repairs for 90 days from the date of Pelco shipment. All goods requiring warranty repair shall be sent freight prepaid to Pelco, Clovis, California. Repairs made necessary by reason of misuse, alteration, normal wear, or accident are not covered under this warranty.

Pelco assumes no risk and shall be subject to no liability for damages or loss resulting from the specific use or application made of the Products. Pelco's liability for any claim, whether based on breach of contract, negligence, infringement of any rights of any party or product liability, relating to the Products shall not exceed the price paid by the Dealer to Pelco for such Products. In no event will Pelco be liable for any special, incidental or consequential damages (including loss of use, loss of profit and claims of third parties) however caused, whether by the negligence of Pelco or otherwise.

The above warranty provides the Dealer with specific legal rights. The Dealer may also have additional rights, which are subject to variation from state to state.

If a warranty repair is required, the Dealer must contact Pelco at (800) 289-9100 or (559) 292-1981 to obtain a Repair Authorization number (RA), and provide the following information:

1. Model and serial number
2. Date of shipment, P.O. number, Sales Order number, or Pelco invoice number
3. Details of the defect or problem

If there is a dispute regarding the warranty of a product which does not fall under the warranty conditions stated above, please include a written explanation with the product when returned.

Method of return shipment shall be the same or equal to the method by which the item was received by Pelco.

### RETURNS

In order to expedite parts returned to the factory for repair or credit, please call the factory at (800) 289-9100 or (559) 292-1981 to obtain an authorization number (CA number if returned for credit, and RA number if returned for repair).

All merchandise returned for credit may be subject to a 20% restocking and refurbishing charge.

Goods returned for repair or credit should be clearly identified with the assigned CA or RA number and freight should be prepaid. Ship to the appropriate address below.

If you are located within the continental U.S., Alaska, Hawaii or Puerto Rico, send goods to:

Service Department  
Pelco  
3500 Pelco Way  
Clovis, CA 93612-5699

If you are located outside the continental U.S., Alaska, Hawaii or Puerto Rico and are instructed to return goods to the USA, you may do one of the following:

If the goods are to be sent by a COURIER SERVICE, send the goods to:

Pelco  
3500 Pelco Way  
Clovis, CA 93612-5699 USA

If the goods are to be sent by a FREIGHT FORWARDER, send the goods to:

Pelco c/o Expeditors  
473 Eccles Avenue  
South San Francisco, CA 94080 USA  
Phone: 650-737-1700  
Fax: 650-737-0933

## REVISION HISTORY

Manual #	Date	Comments
C401M	8/87	Original version.
C401M-A	2/90	Manual revised to incorporate new manual style, UL information, and additional mounting plate installation information and dimension diagram.
C401M-B	6/95	Noted camera mounting bracket is reversible. Put into new format.
C401M-C	12/99	Revised to new format. Removed Figures 1 and 2.

® Pelco, the Pelco logo, Spectra, Esprit, Genex, Legacy, and Camclosure are registered trademarks of Pelco.

™ Endura and ExSite are trademarks of Pelco.

® Lucite is a registered trademark of Lucite

© Copyright 1999, Pelco. All rights reserved.