

Split System Submittal Data



Building Life.

System: 42TW72R Indoor/Outdoor: THW4272R/C4272R
Ceiling Suspended Air Conditioner

Job Name: _____
 Location: _____
 Engineer: _____
 Submitted to: _____
 Submitted by: _____
 Reference: _____

Approval: _____
 Date: _____
 Construction: _____
 Unit #: _____
 Drawing #: _____



General Data (at 230V)

Power	V/PH/Hz	230/208/1/60
Circuit Ampacity	(A)	15-40 Indoor-Outdoor
Fuse Size, Max.	(A)	15-40 Indoor-Outdoor

Compressor		DC Rotary Inverter
No. used		1
R.L. Amps - L.R.	(A)	18.1-31.0
Crankcase Heater	(W)	-

Outdoor Unit		
Fan type		Propeller
Dia. (in.) - No. Speeds		18-7/64-2
Type Drive - No. Speeds		Direct Inverter
No. Poles	(RPM)	8 - 830
No. Motors	(W)	2-90
CFM	(High)	3531
F.L. Amps	(A)	19.7

Coil Type		Aluminum Fin & Copper Pipe
Fin Type - Pipe Type		Slit Plate - Inner Rifled
Rows - F.P.I.		2-12.7
Face Area	(sq.ft.)	11.62
Tube Size	(in.)	3/8"

Indoor Unit		
Fan type		Centrifugal
Dia. & Length (in.) - No. Speeds		5-29/32 - 4
No. Speeds		3 & Auto
No. Poles	(RPM, High)	4-1099
No. Motors	(W)	1-100
CFM	(Hi/Med/Lo)	1130/950/775
Indoor Sound Rating	(Hi) (dB-A)	44
F.L. Amps	(A)	0.8

Coil Type		Aluminum Fin & Copper Tube
Fin Type - Pipe Type		Slit Plate - Inner Rifled
Rows - F.P.I.		3-14.9
Face Area	(sq.ft.)	3.51
Tube Size	(in.)	9/32"
Drain Connection Size	(in.)	(1-1/4)

Refrigerant		R410A
Lbs. - R410a (outdoor unit)		7.94
Control		Electric Expansion Valve
Connection		Flare
Line Length, Max		165
Lift Difference, Max		50 (Outdoor lower), 100 (Outdoor higher)
Line Size	(in. O.D. Discharge)	3/8"
Line Size	(in. O.D. Suction)	5/8"

Dimensions	(in.)	H x W x D
Indoor Unit	(Uncrated)	9-7/16 x 62-1/32 x 26-3/8
	(Crated)	12-15/32 x 66-1/16 x 31-1/6
Outdoor Unit	(Uncrated)	48-7/16 x 37 x 13-3/8
	(Crated)	52-3/8 x 39-31/32 x 16-3/32

Weight		Indoor	Outdoor
Net	(lbs.)	84	220
Shipping	(lbs.)	97	240
Shipping Volume	(cu.ft.)	14.8	19.5

Performance Data @ ARI Standard Conditions (230V)

Cooling		
Total Capacity	(BTU/H)	39,000 (9,500-39,000)
Sensible Capacity	(BTU/H)	23,560
Latent Capacity	(BTU/H)	15,440
SEER		15.6
Dehumidification	(Pints/H)	12.6
Amps	(A)	21.1/23.3
Power Inputs	(W)	4,140/4,140
Outdoor Sound Rating	(dB-A)	53

➔➔➔ Dimensions

Feature

Controls		Microprocessor
Remote Controller	LCD Wired Type, Temp.	Sensor Built In
Temperature Control		IC Thermostat
Timer		72HR, ON/OFF
Night Setback		Built-In
Air Louver	(Horizontal)	Manual
	(Vertical)	Automatic
Power Failure Automatic Restart		Built-In
Self-Diagnosis		Built-In
Air Filter		Washable, Anti-Mold

Option

Refrigerant Line Set	Available
Fresh Air Intake	Knock-Out
Condensate Drain Pump	Available
Wireless Remote Controller	Available
Non-Removeable Remo-con Bracket	Available

Operating Range

		Indoor Air Intake Temp.	Outdoor Air Intake Temp.
Cooling	Maximum	95F DB/71F WB	115F DB
	Minimum	67F DB/57F WB	0F DB

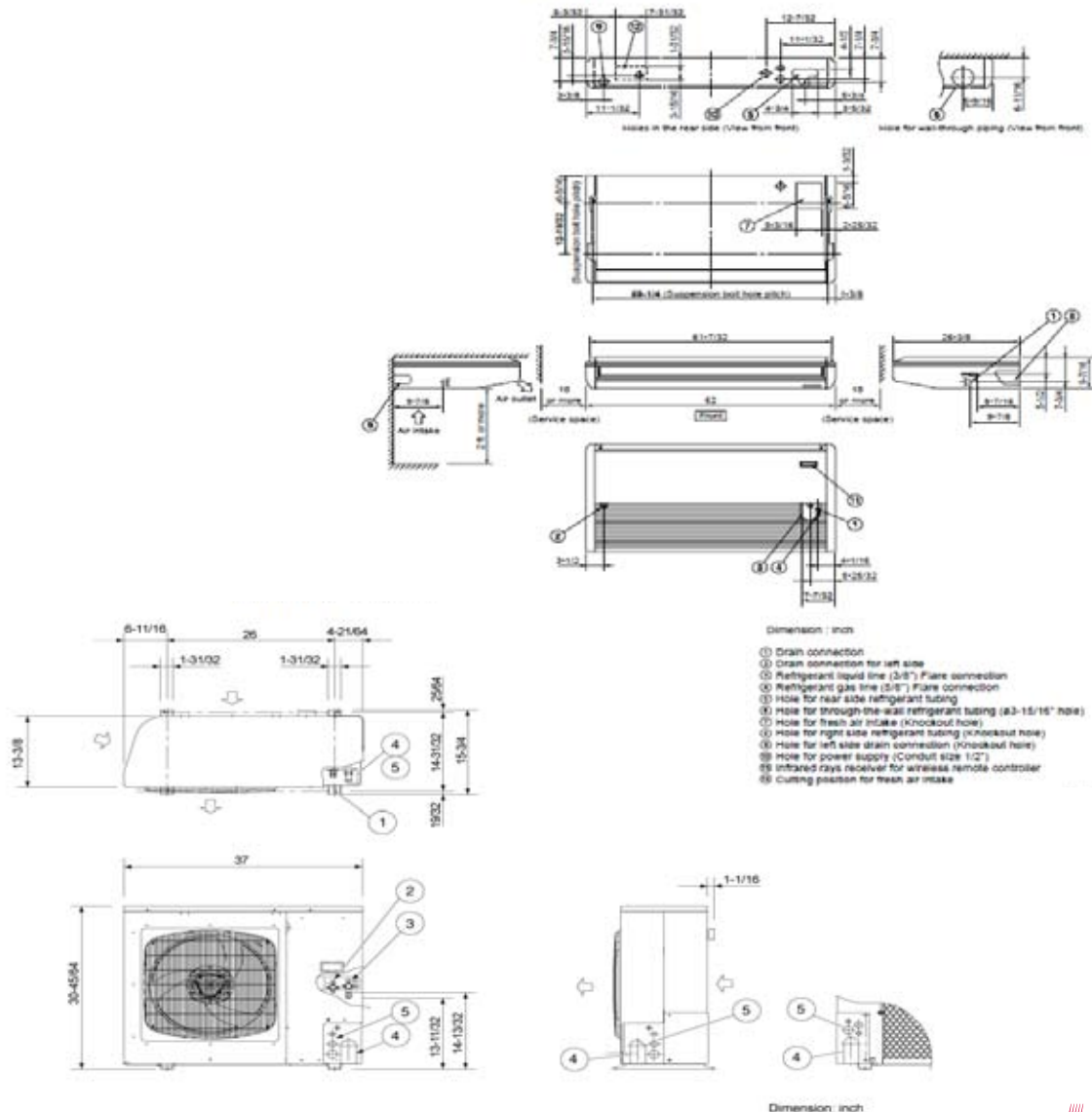

①	Hole for anchor bolt (4-R6.5) / Anchor bolt: M10
②	Refrigerant tube joint (liquid line tube) • Flare connection 3/8 in (9.52 mm)
③	Refrigerant tube joint (gas line tube) • Flare connection 5/8 in (15.88 mm)
④	Refrigerant tubing inlet (knock-out hole)
⑤	Power supply inlet (knock-out hole) ø38, ø29, ø19, ø16 mm

