

LX7007 pro IGC **V1.0**

Variometer and GPS-Navigation System

Draft



Contents

1	GENERAL	4
1.1	TECHNICAL DATA.....	4
1.2	ROTARY SWITCHES AND KEYS (BUTTONS).....	5
1.2.1	ON/START button - Switching the Instrument ON and OFF.....	5
1.2.2	MODE selector (rotary switch).....	6
1.2.3	UP/DOWN selector (rotary switch).....	6
1.2.4	ENTER button.....	6
1.2.5	ESC/OFF button.....	6
1.2.6	EVENT button.....	6
1.2.7	MC and BAL buttons.....	6
1.2.8	ZOOM (rotary switch).....	6
2	OPERATING MODES	7
2.1	SETUP.....	7
2.1.1	SETUP of Options not Requiring the Password.....	7
2.1.1.1	QNH RES (QNH and Safety Altitude).....	8
2.1.1.2	LOGGER (FLIGHT RECORDER).....	8
2.1.1.3	INIT.....	11
2.1.1.4	DISPLAY.....	12
2.1.1.5	TRANSFER.....	12
2.1.1.6	PASSWORD.....	12
2.1.2	SETUP of Options Requiring Access by Password.....	13
2.1.2.1	AS SELECT (selection of airspace section).....	13
2.1.2.2	TP (Turn point).....	13
2.1.2.3	OBS. ZONE (Observation Zone).....	14
2.1.2.4	WARNINGS - Airspace Penetration and Height Warnings.....	19
2.1.2.5	SETUP GPS.....	20
2.1.2.6	UNITS.....	20
2.1.2.7	GRAPHIC.....	21
2.1.2.8	EDIT PILOTS (Pilot list).....	23
2.1.2.9	SETUP NMEA.....	25
2.1.2.10	SETUP PC.....	25
2.1.2.11	DEL TP/TSK.....	25
2.1.2.12	GLIDER POLAR.....	25
2.1.2.13	LOAD.....	26
2.1.2.14	SETUP TE COMP.....	26
2.1.2.15	SETUP INPUT.....	27
2.1.2.16	SETUP LCD INDICATOR (LCD – Vario Indicator).....	27
2.1.2.17	COMPASS.....	29
2.1.2.18	ENL (Engine Noise Level).....	29
2.1.2.19	PAGE 1 (Main Navigation Page).....	29
2.1.2.20	PAGE 3 (Additional Navigation Page).....	30
2.1.2.21	SETUP AUDIO.....	30
2.1.2.22	SETUP ALARMS.....	30
2.2	NAVIGATION FUNCTIONS.....	30
2.2.1	GPS Page.....	30
2.2.2	NEAR AIRPORT.....	31
2.2.3	APT Airports, TP Turn Points and TSK Tasks.....	31
2.2.3.1	Navigation in APT, TP or TSK.....	32
2.2.3.2	Airport Selection, Team and Wind Calculation.....	33
2.2.4	TP - Turn Points.....	35
2.2.4.1	TP SELECT.....	35
2.2.4.2	TP EDIT.....	36
2.2.4.3	TP NEW.....	36
2.2.4.4	TP delete.....	36
2.2.4.5	TEAM.....	36
2.2.4.6	WIND.....	36
2.2.4.7	TP QUICK - Storing of actual position.....	36
2.2.5	TSK - Task.....	37
2.2.5.1	TSK - SELECT.....	38
2.2.5.2	TSK - EDIT.....	38
2.2.5.3	TSK - NEW.....	40
2.2.5.4	TSK - DECLARE.....	40
2.2.6	STATISTICS.....	41

2.2.6.1	Statistics during flight	41
2.2.6.2	Statistics after flight.....	42
2.3	VARIOMETER AND ALTIMETER.....	43
2.3.1	<i>Smart Vario description</i>	44
2.3.2	<i>Altimeter</i>	44
2.3.2.1	IGC barogram recalibration procedure.....	44
2.3.3	<i>Speed command</i>	44
2.3.4	<i>Final glide calculation</i>	45
2.4	FLYING WITH THE LX 7007 PRO IGC	45
2.4.1	<i>Switching ON and selecting pilot</i>	45
2.4.2	<i>SET Elevation (take off elevation input)</i>	46
2.4.3	<i>Preflight check</i>	47
2.4.4	<i>Performing the flight</i>	47
2.4.4.1	Preparing a task	47
2.4.4.2	Starting a task.....	48
2.4.4.3	Automatic swap on reaching a TP using standard task and AAT	49
2.4.4.4	Use of MOVE function	49
2.4.4.5	TSK END	50
2.4.4.6	Procedure after landing	50
2.4.4.7	SIMPLE TASK	51
3	PC, PDA AND COLIBRI/LX20 COMMUNICATION	51
3.1	COMMUNICATION WITH PC	52
3.1.1	<i>Some help having problems with communication</i>	53
3.1.1.1	General.....	53
3.1.1.2	Troubleshooting with LXE.....	54
3.1.1.3	Recommended LXE settings for safe communication.....	55
3.1.2	<i>Having problems downloading flights (read selected flight-command)</i>	56
3.1.3	<i>Additional help from LX navigation</i>	56
3.2	COMMUNICATION WITH PDA.....	57
3.2.1	<i>Connect procedure to PDA</i>	57
3.3	COMMUNICATION BETWEEN LX 7007, COLIBRI OR LX 20	58
3.3.1	<i>Data transfer LX 7007-LX 20</i>	58
3.3.2	<i>Data transfer LX 7007-Colibri</i>	58
4	INSTALLATION	59
4.1	INSTALLATION OF PDA UNITS	60
4.2	LX 7007 PRO IGC FULL CONFIGURATION (ALL CONNECTIONS PLUG AND PLAY)	61
4.3	WIRING	63
4.4	TREE STRUCTURE DIAGRAM	65
5	PASSWORDS.....	66
6	OPTIONS	67
6.1	LX 7007 PRO IGC - COMPASS MODULE	67
6.1.1	<i>General</i>	67
6.1.2	<i>Installation of the compass module</i>	68
6.1.2.1	Where to install:	68
6.1.2.2	First test after installation:	68
6.1.3	<i>Adjusting the compass module:</i>	68
6.1.4	<i>Final test:</i>	68
6.1.5	<i>Wind calculation during flight</i>	69
6.2	LX 7007 PRO IGC – REMOTE CONTROL UNITS.....	70
6.2.1	<i>Remote control keyboard type</i>	70
6.2.1.1	General.....	70
6.2.1.2	Getting started	70
6.2.1.3	Electronic connection	71
6.2.2	<i>LX 7007 PRO IGC – Remote K- Stick mounted unit</i>	71
6.2.2.1	General.....	71
6.2.2.2	LX 7007 PRO IGC Remote K configuration.....	71
6.2.2.3	Stick handle with keys.....	71
7	REVISION HISTORY	72

1 General

The instrument consists of two units, the **LX 7007 DU** main unit, and the **LX 7007 AU** LCD Vario indicator unit. The 80mm diameter (3") main unit LX 7007 DU is fitted with an integral 12 channel GPS receiver and a high resolution display with 160x240 pixels. The 57 mm diameter (2 1/4") LX 7007 AU is a new design with its own integral micro processor and communicates with the LX 7007 DU via the RS 485 system bus. Optionally, additional LX digital Vario indicators can be daisy chained using the RS 485 bus.

Vario functions include:

- Vario, Netto, Relative (Super Netto) and Averager (new algorithms for vario signal acquisition added)
- Speed command
- Final glide calculator
- TE compensation is selectable for either pneumatic TE tube, or electronic TE

Navigation functions include:

- Airport and airspace database for Europe or USA (up to 5000 airports)
- 600 turn points
- 100 tasks
- Statistics
- Display of nearest airports
- Support of AAT (assigned area task)

What does LX 7007 PRO IGC mean?

The LX 7007 PRO IGC has an integral **IGC approved flight recorder** utilizing a dedicated pressure sensor for pressure altitude recording based on 1013.2 hpA (29.92"). An integral engine noise capability is fitted for self sustaining and self launching sailplanes. The firmware ensures data integrity and meets all IGC requirements regarding security of the flight record data.

1.1 Technical data

- Power 8-16 V DC
- Consumption 400mA @ 12V (without audio)
- 80mm (3") standard Aircraft cut-out for LX 7007 DU
- 57mm (2 1/4") standard Aircraft cut-out for LX 7007 AU
- Length 120 mm (incl. connector)
- There physically separated com. Ports:
 - PDA port with 5V power supply, delivers NMEA or allows data exchange LX 7007-PDA
 - PC port
 - IGC com port with IGC standard connector, suitable to connect Colibri or LX 20
 - User com. port for some future applications
- Drives SeeYou mobile, Navigator, Winpilot....
- PDA communication with Connect LX
- 12 Channel GPS receiver
- memory space to store the whole European airspace
- External speaker
- Built in fuse to prevent damages in stead of a short on 485 bus
- Data compatible with LX 20 and Colibri
- IGC approved flight recorder
- Wiring
- Additional LCD Vario, rear seat unit, remote control and compass options can be connected via the RS 485 bus
- Weight: 800g

1.2 Rotary switches and keys (buttons)

The following controls are mounted on the front face of the LX7007 DU

- Four rotary selector switches
- Six push buttons

The LX7007AU is an indicator only and has no controls; the displayed information being controlled from the LX7000DU

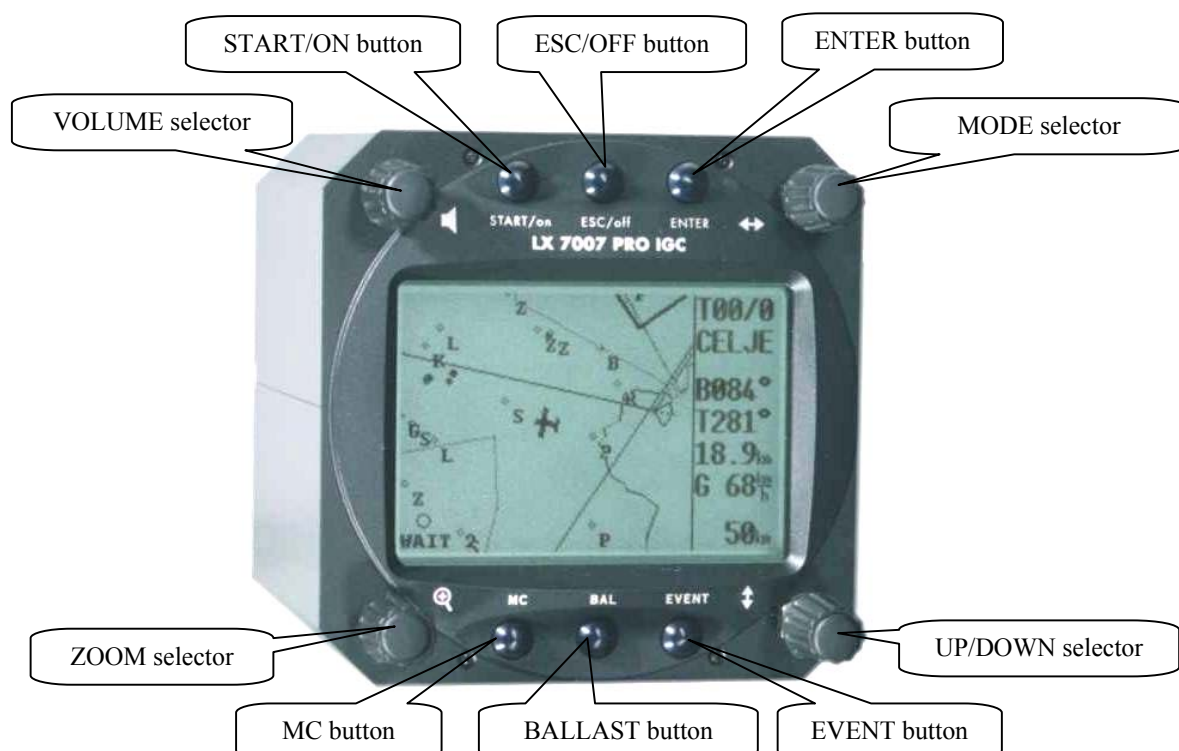

1.2.1 ON/START button - Switching the Instrument ON and OFF

The **ON/START** button is multifunctional. If the instrument is not already powered up, a short press on the **ON/START** button will switch the instrument **ON**. To switch the instrument **OFF**, press the **ESC/OFF** button for a few seconds and the instrument will switch off. If an attempt is made to switch the instrument off during flight, the instrument requires confirmation from the pilot, **so the LX 7007 PRO IGC cannot be switched off by mistake**. On powering the unit, the first screen shows the firmware version, database version, serial number of the unit, and total memory in hours available for IGC flight records. After a few seconds, a second screen shows details of the glider and pilot. The unit is equipped with a facility of storing up to 30 pilot names. If no names are stored, the unit shows the pilot name as UNKNOWN. By rotating the **UP/DOWN** selector, the display scrolls through the programmed pilots. Once the correct pilot is selected, pressing the **ENTER** button selects the airfield elevation screen and the current elevation should be entered, again using the **UP/DOWN** selector and the **ENTER** button. Similarly, the current QNH should also be entered. The airfield **elevation** input is **mandatory** while the **QNH** input **optional** (See Para 3.1.1.1)

During flight the same button is used to **start the task, to see more characters of airport names and, in the edit menu, to go back one step** if an error has been made (see paragraph APT).

Note!:

During flight, if main power is lost for a few seconds, **the flight recorder will not produce two flights**. The most important flight parameter, altitude will remain, which means that the final glide is not interrupted.

1.2.2 MODE selector (rotary switch)

The mode selector is used to change modes of operation. This switch has the **highest priority** in the system. Whenever it is operated, **a mode change will occur**.

1.2.3 UP/DOWN selector (rotary switch)

This rotary switch has a lower priority than the mode selector switch and is active all the time in the selected mode. It is mainly used for selecting sub menus during navigation and to scroll in the edit menu.

1.2.4 ENTER button

The main function of this key is **confirmation**, and **to start edit procedures**.

1.2.5 ESC/OFF button

This is a multifunctional key, which has two main functions. If it is pressed and held for a few seconds, then the instrument will turn OFF as outlined in para 2.2.1 above.

If a short press is made, then the button has the following functions:

- The display will jump to the menu of the next higher level (in edit only)
- During alpha-numeric input with the cursor active (blinking), **ESC confirms the whole line** (It is not necessary to press ENTER few times)
- Some special functions can be activated using ESC as described in subsequent paragraphs

1.2.6 EVENT button

Activates the Event function (see Chapter 3.1.1.2, Flight Recorder)

1.2.7 MC and BAL buttons

Pressing these buttons activates the Mc Cready (MC) and ballast setting as shown below. The value is then changed with the UP/DOWN-selector. There is no secondary function of these buttons.

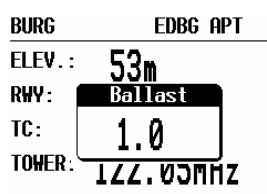
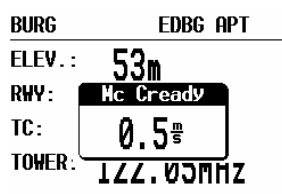

1.2.8 ZOOM (rotary switch)

This is a multifunctional rotary switch. While its main function is to change the **zoom level in the graphic mode**, it can also be used as follows:

- To select turn points when in the main TP page
- To select task when in the main TSK page
- If an error is made during editing, it is possible to move the cursor back by rotating this knob. This can only be done if 'editing' is active which is shown by the cursor blinking

2 Operating modes

The LX 7007 PRO IGC has 7 modes or main menus. All of them are selectable **directly by rotating the MODE switch**. The diagram shows the menu (mode) structure of LX 7007 PRO IGC.

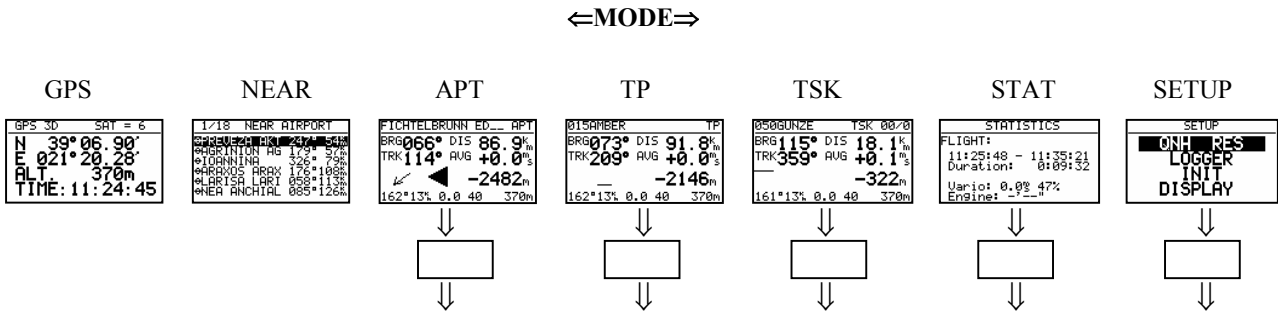

Navigation menus (APT, TP and TSK) have sub menus, which can be selected using the **Up/Down** switch.

- GPS** GPS status, no inputs possible
- NEAR** Near airport, select one airport of interest, no further inputs are possible
- APT** Navigation and selection of airports
- TP** Navigation, selection and editing of turn points
- TSK** Navigation, selection and editing of tasks
- STAT** Flight statistics and logbook

SETUP has two levels. The first level, for which no password is required, is fully accessible. To activate the second level, it is necessary to input a password. The password is not top secret; it is the same for all instruments and is freely available.

96990

The selection of the system parameters that are fixed, such as glider type, units, polar etc, are only access able by entering the password. This facility prevents that well known gliding club pest, "the random knob twiddler" from changing the important fixed parameters just before you launch on the flight of the year! Once you are airborne, then the password is not necessary - the second level can be entered simply by selecting **PASSWORD** and pressing **ENTER**.

2.1 SETUP

2.1.1 SETUP of Options not Requiring the Password

The first five options are selected with the **UP/DOWN** switch and can be entered at any time; they contain **no system settings**.



Once the desired option has been selected, press **ENTER** to access the sub-menu.

2.1.1.1 QNH RES (QNH and Safety Altitude)

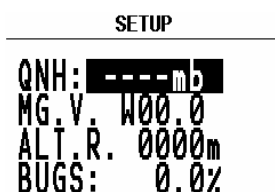

Input Procedure:

- Use the **UP/DOWN** selector to choose the item it is required to change (QNH, MG.VAR, ALT.R. or BUGS)
- Press **ENTER**
- Use **UP/DOWN** to select the value required and press **ENTER** to input it
- Once all changes are complete, press **ESC** to return to SETUP menu

QNH: Using this feature it is possible to offset the altitude datum, which could have changed due to pressure changes during the flight. During the initial power up sequence, an option to enter the QNH was presented. If the actual QNH was entered at that stage, then this feature is active. If the QNH feature was 'stepped over' during power up, then this function is not active. As changing the QNH influences the indicated altitude, care should be taken when changing the value as an incorrect setting can upset the final glide calculation.

MG. V. If the GPS receiver calculates **magnetic variation** then AUTO will be displayed here and no input is possible. If AUTO is not displayed, then the GPS receiver is not calculating magnetic variation and it is obligatory to input the magnetic variation for the area being flown over. If this is not done, then all calculated winds and tracks flown will be true and not magnetic.

ALT.R. This setting is the altitude reserve or safety altitude, and is the height that the instrument adds to the final glide altitude required so that the glider arrives over the final glide destination at the selected safety altitude. After safety altitude input, the pilot has to keep final glide indicator on 0 to arrive on safety altitude.

BUGS: This sets the polar degradation because of "buggy" wings. The input is in percentage degradation of glide ratio. (5%, means glide ratio degradation is 5%)

2.1.1.2 LOGGER (FLIGHT RECORDER)

The flight recorder is fully approved by the IGC (A sub-committee of the FAI.) and will produce secure flight records that are acceptable for all FAI requirements including world records.

After selecting **LOGGER** and pressing **ENTER**, the following flight recorder settings are accessible.



FLIGHT INFO All important data, such as the pilot's name, glider type, glider registration, competition number and competition class can be entered. The data is entered with the **ENTER**, **UP/DOWN** and **ESC** routine. This data is subsequently written into the 'H' record of the IGC flight log. Alternatively, this data can be entered with a PC and the LXe-program; or via a Colibri or LX20 (see Chapter 4).

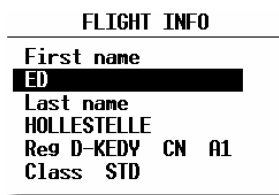

Note!:

The instrument is capable of storing up to 30 different pilot's names. Each pilot's name, which can be password protected, can have different flight information programmed into it. This is useful if one likes to fly with a custom polar, fly the glider in different configurations, or fly in decentralized competitions, Online-Contest, Barron-Hilton-Cup, etc. For more information on configuring pilot names see 3.4.1, and for for setting custom polars see 3.1.2.10.

Before leaving the FLIGHT INFO menu, the actual name can be saved into pilot list, if not already present.



Note!:

If only one pilot flies the glider, then after entering his name, it is not necessary to enter it into the list. In the above screen 'N' should be selected to do this. The name will then appear automatically on instrument power up together with all the parameters that have been set. An exception to this is if he flies the glider in two different configurations; then he should list his name twice, e.g once with a suffix of 15m and again with a suffix of 18m with different polars in each name.

LOGTIME is an important parameter as it shows the total memory available for recording the flight.

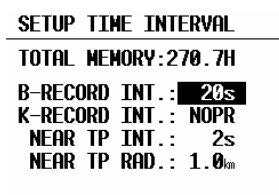

TOTAL MEMORY is the **capacity of memory** in hours that can be stored and only depends on the settings. It does not decrease as flights are stored and will only change after new settings have been made in the setup. **If the memory is full, the oldest flights will be overwritten without warning.** The total memory simply indicates how many hours of flight can be made without losing any flight data before overwriting occurs.

B-RECORD: This is the main IGC record in which position, GPS altitude, pressure altitude, UTC and GPS status are stored. The default interval is 12 seconds and it can be changed. As the interval is reduced, the Total Memory will be seen to decrease.

K-RECORD: This record can be used to store non-essential flight parameters and is not active by default. It should not be activated unless the IGC record format is fully understood. If required to be activated, the J-Record (see below) will select the flight parameters that are stored in the K-Record.

NEAR TP INT: This setting enables the fixing rate set by the B-Record to be increased close to a turnpoint to ensure that a fix is obtained in the observation zone.

NEAR TP RAD: This setting defines the radius from the turnpoint at which increased fixing rate is to start.

(I) RECORD: This record permits additional flight parameters to be added to the B-Record. Except for ENL (Engine Noise Level), they are all de-activated by default. They can be activated if required by toggling the 'N' to 'Y'.

- FXA: current horizontal accuracy of GPS
- VXA: current vertical accuracy of GPS
- RPM: engine RPM
- GSP: ground speed
- IAS: indicated airspeed
- TAS: TAS
- HDM: mg. heading
- TRM: magnetic track
- TRT: true track
- TEN: total energy
- WDI: wind direction
- WVE: wind
- VAR: vario
- ENL: engine noise level (**default Y**)

Each setting activated will reduce the **total memory capacity**.

(J) RECORD: The J-Record defines the flight parameters that are to be stored in the K-Record. These parameters are the same as those used for the I-Record. Using this record will reduce the total memory **by about half**.

Note!:

Unless the user has a good understanding of the composition and use of IGC flight records, then it is recommended that, other than the ENL, no alterations are made to the default selections.

EVENT This option programs what happens on pressing the **EVENT** button. On pressing the button, the flight recorder places a special marker, called a PEV (Pilot Event), in the IGC flight record. At the same time, it causes the recorder to run at a different fix interval for a certain time. The interval and time are set up in this option. Competition rules may require the **EVENT** to be activated at some stage during the flight.

SETUP EVENT MARKER

FIX INTERVAL: **2s**
NUMBER OF FIX: **30**

Example:

The setting above will cause the recorder to log 30 additional fixes at 2-second intervals on pressing the **EVENT** button.

2.1.1.3 INIT

The following parameters can be set using this option.

```

INITIALIZE
VAR.FIL: 2.0 S.V. OFF
VARIO INT.: 20s
VARIO RNG.: 5%
TAB: 1.0% ETA: GS
AUTO SC: OFF
WIND/COMPASS: N.C.

```

- **VARIO FIL:** This sets the time constant of the vario from 0.5sec up to 5 secs; the default setting is 2.0 secs
- **S.V. :** S.V. means Smart Vario, giving four levels of dynamic damping of the vario indication and off.
- **VARIO INT:** This setting defines integration period for the averager in seconds; the default is 20 seconds
- **VARIO RNG:** This sets the full scale range of the vario
- **TAB:** This setting defines the width of the audio dead band in speed to fly mode
- **ETA:** This setting selects the parameter, **GS, VAR or MC**, that is used to calculate the **Estimated Time of Arrival**. When flying a programmed task, the calculation takes account of the unflown portion of the task, around any TPs or APTs not yet reached

GS, bases ETA on the achieved groundspeed along track. It takes into account differences between bearing and track of up to 90°. If the difference is greater than this, --:-- is displayed.

VAR is based on the achieved average thermal climb rate and assumes that this is going to continue.

MC is based on the actual Mcready setting.

Note!:

All three methods of calculating ETA and ETE (**Estimate Time of Arrival, Estimate Time Elapsed**) take into account glider altitude and safety (arrival) altitude, thus ensuring that the calculation made is the best available

- **AUTO SC:** This option defines the method by which the instrument is switched between vario and speed command
OFF: Switching is by an external switch
GPS: When the GPS detects that the glider is circling
TAS: When the TAS exceeds a pre-set value. The TAS at which switching occurs can be selected in 5 km/h steps from 100 up to 160 km/h (or the equivalent in knots or mph)
- **WIND/COMPASS:** N.C. means not connected. When the optional compass module is installed, the instrument uses magnetic track to make an additional wind calculation. The calculation requires the glider to fly straight a specified period which is set in this option. The default is 15 seconds, but the longer the period, the more accurate is the calculated wind.

Note!:

The external switch option has absolute priority and will override all other switching methods.

2.1.1.4 DISPLAY

This option sets the contrast of the LC display. The actual contrast can vary with viewing angle, ambient light level and temperature. The contrast is changed by rotating the **UP/DOWN** selector.

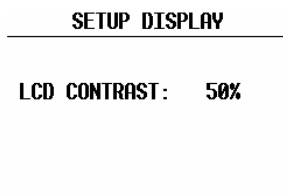

Default contrast setting is 50%.

2.1.1.5 TRANSFER

This option initiates the transfer of data between the instrument and a connected PC, PDA, LX 20 or Colibri. Data transfer is started by pressing **ENTER** with **TRANSFER** selected.

A dialog will open and the pilot has to select the destination.

PC
PDA
COLIBRI/LX 20
IGC PORT

Note!

After **ENTER** on **PC** the communication LX 7007 – PC via 5P connector usually mounted on the instrument panel will be possible. After enter on **IGC PORT** a PC communication via IGC port and IGC standatd connector will be possible.

After PDA activation data exchange LX 7007 – PDA will be possible, suggested program is ConnectLX. Available on www.lxnavigation.si or www.seeyou.ws.

Note!

PDA port is under normal conditions delivering NMEA data sentences to run PDA (SeeYou Mobile, Navigator Winpilot...) and powers PDA at the same time.

After Enter on Colibri/LX 20, the data exchange with eventually connected Colibri or LX 20 device will be possible (read/write TP&TSK, read and write of flight info).

Note!

As mentioned before, all three communications ports are physically separated and therefore no data collision problem could occur, even all devices connected and on.

See Chapter 4 for further details.

2.1.1.6 PASSWORD

Certain system parameters can only be entered through this option. Full details are in the following paragraph, 3.1.2.

The Password is 96990

2.1.2 SETUP of Options Requiring Access by Password,

After entering the password, **96990**, a further 21 system settings are available. During flight the password is not required, which means that when **ENTER** is selected in the Password option during flight, **the LX 7007 PRO IGC goes immediately into the following setup menu!**

2.1.2.1 AS SELECT (selection of airspace section)

The unit is able to store up to 6 sections (0 up to 5) of airspace, which means practically the whole European airspace. The unit is delivered fully loaded. Selection of suitable area should be done by pilot using of this menu. After selection simple press Enter and loading procedure will start automatically. To make airspace visible on PC screen use LXe or LXAsbrowser PC program.

Note!

To reload a new airspace section (.CUB format only) is done simple by overwriting of actual active airspace using of LXe PC program, **exclusively**.

Note!

To prepare custom airspace, in .CUB files, use our special tool for airspace creation and manipulation, called LxAsbrowser, available for free on www.lxnavigation.si or on LXe CD.

EU-N..... N,S, GB*, FIN*
 EU- W..... SP,P, F*, GB*, IRL*
 EU-CS..... CH, A, SLO, F*, D*, CZ*, HR*, I*
 EU-CW..... BENELUX, CH, DK, D*, F*
 EU-NE..... N, S, DK, FIN*
 EU-S..... CH, I, SLO, F+, HR*, A*
 EU-C..... D, NL, CH, DK, A*, CZ*, B*
 EU-E..... CZ, SK, PL, H, SLO, D*, HR*, RO*
 EU-NW..... GB, IRL, BENELUX, Iceland, F*
 EU-SW..... P, SP, F

* Not fully covered county.

Note!

Selection of believable airspace section is possible during the flight too and will take apr. one second.

2.1.2.2 TP (Turn point)

All settings concerning turn points can be done in this menu. The LX 7007 PRO IGC is able to store 600 turn points in a proprietary format (*.DA4).

SETUP TP

```

TP-QUICK POINT NAME
DATE: OFF AP
TP-QUICK POINT AUTO
SELECT: OFF
NEAR RADIUS: 0.5km
TP-SORT: ALPHABET
  
```

TP-QUICK POINT NAME

The pilot is able to store his **actual position** during the flight by pressing the **START** button in **TP** mode in the **first navigation page** (see Para 3.2.4.7). These turn points are called QUICK TP and are given the default name **AP** (actual point).

Settings:

DATE: OFF stores the position as **AP: 12:35**. The numbers are the time that the TP was stored.

DATE: ON stores the position with the date and time (**28121330 for 28 Dec. 13:30**).

TP-QUICK POINT – AUTO

When **SELECT: OFF** is selected, the actual position will not be selected for navigation

When **SELECT: ON** is selected, the actual position will be selected automatically and displayed in the navigation page.

NEAR RADIUS

The setting has nothing to do with the setting described in **LOGGER**. The LX 7007 PRO IGC has a very useful feature named “Simple task” which is active when a regular task is not set. When the instrument detects that it is within the **Near Radius** a turn point in the memory, then that turn point can be treated like a confirmed TP of a simple task. This gives the ability to provide in-flight statistics for subsequent evaluation without setting a full task. For more information on this feature see Chapter 3.4, flying with the LX 7007 PRO IGC.

TP-SORT

The LX 7007 PRO IGC is able to sort the turn points **either alphabetically** or **by actual distance** from the present position. If sorted under distance **the nearest TP** will be the first to be displayed when selecting the turn points.

2.1.2.3 OBS. ZONE (Observation Zone)

This menu defines sector geometry.



The following sectors can be programmed:

- The **START ZONE**
- The turn **POINT ZONE**
- The finish line (**FINISH ZONE**)
- **TEMPLATES**

Selecting the **TEMPLATES** option will program all sectors identically. The only **TEMPLATES** available are the 90⁰-FAI photo sector and the 500m-cylinder.

The sectors are programmed by defining two angles, two radiuses and the orientation. All settings done here are “global”, which means the definition is valid for all programmed tasks. Additionally, up to 5 (five) tasks can have individual sector geometries defined, **even for a single turn point of one task**. This is done using the “local” setting in the corresponding task in the task menu. This is a very useful function, when flying an AAT (Assigned Area Task). These local settings are done in the same way as described below but their incorporation in a specific task is covered in Para 3.2.4.

Note!:

After programming 'local' sector geometries in specific tasks, if the SETUP OBS. ZONE is used to reprogram sectors, then all the 'local' sectors will be overwritten with the new global values!

As will become apparent, the definition of sectors, particularly the start zone are subject to continual change. However, the basic principle of defining the sectors is done as follows:

2.1.2.3.1 START ZONE

To define the start zone, select **START ZONE** and press **ENTER**. The following default screen will be displayed:

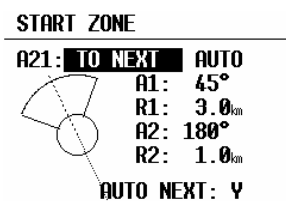

- A21: Orientation (Options: **TO NEXT**, **RAD.1.TP**, and **USER VALUE**). If **TO NEXT** or **RAD.1.TP** are selected, then **AUTO** is also displayed not permitting any rotation. If **USER VALUE** is selected, the sector can be rotated.
- A1: First angle
- R1: Radius of the sector having angle A1, e.g. 3km for the FAI photo sector.
- A2: Like A1, used for creating combined sectors.
- R2: Like R1, also used for combined sectors
- AUTO NEXT (Y,N) defines the change over procedure on reaching the sector.

At first, this sounds complex, but the following examples will help to clarify the meaning of these settings.

Example 1:

The default setting shown above defines the FAI 90° photo sector combined with a 1km radius cylinder. To modify these settings to set the FAI 90° photo sector as the start zone, the parameters are modified as follows:

A21 is set to **TO NEXT POINT** and **AUTO** as the start zone wants to be orientated symmetrically about the track to the first turn point.

A1 is 45°, because the bisector of the FAI 90° sector is needed.

R1 is 3km, the radius of the sector.

A2 and R2 are both 0 as a combined sector is not needed .

Example 2:

Program a 180°, 6km Start Zone:

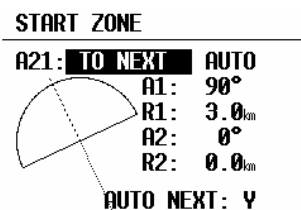

A21: **TO NEXT POINT** and **AUTO**

A1: 90° bisector

R1: 3km radius

A2: 0

R2: 0

Note!:

The IGC competition rules of May 2000 specify the start sector for international championships to be a straight line perpendicular to the first track. This particular option cannot be defined in the LX 7007 PRO IGC and the 180° start sector is programmed as Example 2 above. The only disadvantage of this is that the LX 7007 PRO IGC will record a good start when there is a fix recorded in the zone, whereas in reality a good start is only made when the start line is crossed in the right direction. The diagram below illustrates this:

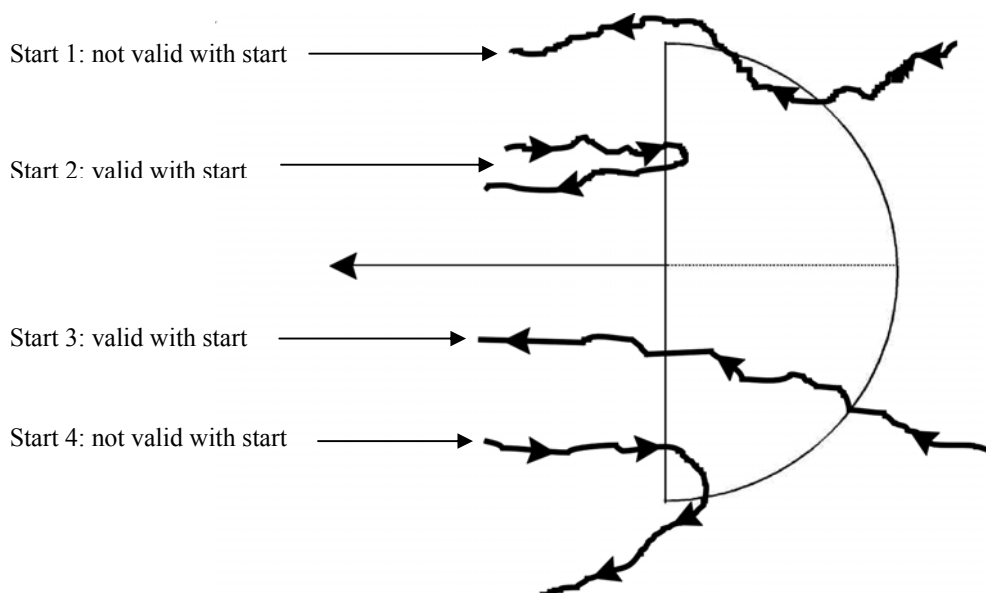

It is therefore recommended that the graphics page is displayed during the start procedure to ensure that a good start is achieved.

Other possible options for the setting of **A21** are:

- RAD.1.TP:** This type of start sector was used in the 1999 World Gliding Championships in Bayreuth. A radius is drawn from the first turn point, through the start point and a second, greater radius is drawn, thus creating a radial segment of defined length orientated symmetrically about the start point. The advantage of this system is that a pilot starting at the extremity of the sector has to fly the same distance to the first turn point as a pilot starting directly over the start point. This refinement compares with the classical start line where the distance to the first turn point is increased the further one starts from the centre of the line.

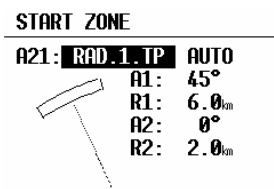

A21: **RAD.1.TP** and **AUTO** are selected

A1: This setting is ignored; only R1, which defines the length of the segment, is relevant

R1: Set to 6km, the half-length of the segment, giving a total segment length of 12km

A2: Again, this setting is ignored

R2: This sets the length of the two truncated radials that define the edges of the start sector. The setting is 2km in this example

- FIXED VALUE:** This setting allows the bearing of the bisector to be rotated so that it is no longer aligned with the track to the first turn point. The required bearing is entered in **A21** after **FIXED VALUE:**. This option is rarely used for start sectors, but is often used for finish zones which may require to be orientated to a particular runway (see "FINISH ZONE").

Note!:

All the examples discussed are intended to explain the programming procedures and present capability of the LX 7007 PRO IGC and do not claim to be comprehensive. Each competition will have its own rules regarding the definition of sectors, which can be found in the particular competition rules. In case of doubt, the rules defined in the FAI Sporting Code Section 3 should be used. In most national decentralised championships, FAI-badges, 1000/2000km diplomas and the Barron-Hilton-Cup, only the 90° FAI photosector is allowed, while for record flights a 1000m startline is used for recording the start time.

2.1.2.3.2 POINT ZONE

This setting defines the turn point zone, sometimes referred to as the observation zone. The procedure is very similar to setting the **START ZONE** except that more options are available for **A21**.

- **SYMMETRICAL:** The axis of the turn point zone is orientated symmetrically about the line bisecting the inbound leg from the previous turn point and the outbound leg to the next turn point.
- **TO PREV POINT:** The axis of the turn point zone is orientated towards the previous turn point. This option is intended for Cat's Cradle and related tasks.
- **TO NEXT POINT:** The axis of the turn point zone is orientated towards the next turn point. This option is also intended for Cat's Cradle.
- **TO START POINT:** The axis of the turn point zone is orientated towards the start point. Again, this is a Cat's Cradle option.
- **FIXED VALUE:** The axis of the turn point zone can be orientated in any specified direction. This is the only option for which **A21** is not set to **AUTO**.

Example 3:

To specify a turn point zone that is a combination of the FAI 90° photo sector and a 500m radius cylinder:

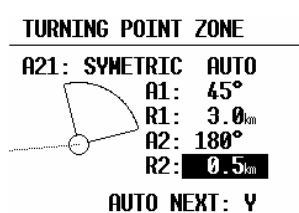

HDG: SYMMETRICAL
A21: AUTO
A1: 45°
R1: 3.0km
A2: 180°
R2: 0.5km

Note!:

It should be noted that when defining combined sectors, the sector with the smaller radius must be designated by A2 and R2 (ie. R1>R2!).

Note!:

While the combined sector is used in many National competitions, it is emphasised that for record flights, FAI badges, 1000/2000km-diplomas and for the Barron-Hilton-Cup, only the FAI 90°-photo sector is valid!

2.1.2.3.3 FINISH ZONE

This setting defines the **FINISH ZONE** or Line. Highlight the **FINISH ZONE** with the cursor and on pressing **ENTER**, a similar screen as for the previous settings is displayed, except that there are only two options for A21:

- **TO LAST LEG:** The axis of the FINISH ZONE is orientated directly back to the last turn point. This is the conventional setting for National competition flights.
- **FIXED VALUE:** The axis of the FINISH ZONE can be orientated in a specified direction (see example 4).

Example 4:

It is required to orientate the finish line perpendicular to the runway 06/24, which is not related to the bearing to the last turn point:

A21: Select **FIXED VALUE** and then enter either 060° or 240°, depending on the direction of the final glide. For example, if the final glide was in direction 240°, then 060° would be entered. The “flat side” of the sector is now directed back to the last leg and the glider will cross the line to enter the sector.

- A1:** 90°
- R1:** 1.0km
- A2:** 0 (not programmed)
- R2:** 0 (not programmed)

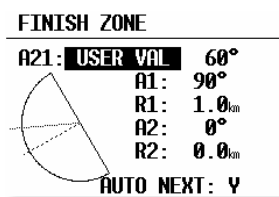

Note!:

There are many ways to complete a flight. For instance, when completing flights for FAI badges or diplomas, it is enough to land inside the airfield boundary if the airfield is the finish point. If a remote finish point is specified, then the appropriate sector must be used. If in doubt, consult the competition rules of the FAI Handbook as appropriate.

2.1.2.3.4 TEMPLATES

Selecting **TEMPLATES** will give the choice to select one of two options: the 500m radius cylinder; or the FAI 90° Photo Sector. When one of these templates is selected, then all the sectors of all tasks will be overwritten with the chosen template without any further confirmation!

Note!:

An exception to this global use of **TEMPLATES** is when the **ZONE** function has been already activated. Use of **TEMPLATES** in this situation will not change sectors already modified. However, using **RESTORE ALL** will change **all** sectors, both AAT and non AAT, to the settings selected in **OBS ZONES** for start, TP and finish sectors



2.1.2.4 WARNINGS - Airspace Penetration and Height Warnings



The LX 7007 pro IGC monitors the glider’s position both horizontally and vertically in relation to SUA, and will give both an acoustic and visual warning prior to the airspace being penetrated. The warning will be activated a specified number of seconds before entering the airspace – **Warn me xxx seconds before**, where XXX is the desired input between 20 and 600 seconds. The default value is 120 seconds. When thermalling, the wind vector is used to calculate the horizontal warning and the achieved climb rate used to calculate the vertical warning. The warning calculation takes into account the specified lower and upper airspace heights and no warning will be given if the predicted flight path is over or under the airspace height limits. The airspace zones for which warnings are required are set by placing a tick in the appropriate box as shown below.

Note!:

Setting “Warn me 120s before” will warn the pilot that the glider will enter airspace in two minutes provided that the horizontal and vertical speeds are not changed.

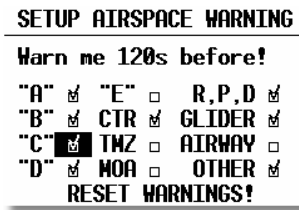

Checked airspace (✓) will cause warnings to be given, and vice versa. Airspace is selected according to the ICAO airspace classifications of A to E. In addition the following other airspace areas can be selected

- CTR control zone
- MTZ mandatory transponder zones
- MOA military operating area
- R,P,D restricted, prohibited, dangerous zones
- GLIDER glider activity zones
- AIRWAYS airways
- OTHER

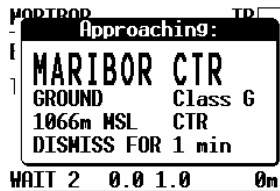

Example of an airspace warning

The **DISMISS** warning can be used to deactivate the particular airspace warning for a period of time. Use the **UP/DOWN** selection to enter the duration for which the warning is required to be deactivated and press **ENTER**. The displayed airspace warning can be **DISMISS**ed from 1 minute to permanent de-activation. **DISMISS** selections can subsequently be cancelled by using **RESET WARNINGS** in the **SETUP/Warnings** screen. Once the warnings have been reset, they can be **DISMISS**ed again if the pilot so desires.

Note!:

Use the **DISMISS** function to temporarily deactivate individual airspace warnings. All warnings can be reinstated using the **RESET WARNINGS** command in the **SETUP/Warnings** screen.

ALTITUDE warnings can be setup in a similar way and inform the pilot that he is approaching pre-selected altitude limits.

```

SETUP ALTITUDE WARNING
Warn me 60s before,
reaching: 2000m

RESET DISMISS TIME!

```

The warning altitude is always above MSL (Mean Sea Level). The warning will be activated at a specific time before reaching the altitude limitation. While thermalling, the achieved climb rate is used to calculate when the warning altitude is going to be reached and similarly, in straight flight, the descent rate is the controlling parameter. Operation of the altitude warning is the same as for the airspace warning and use of the DISMISS and RESET DISMISS TIME commands are identical.

```

Approaching:
1000m MSL
Altitude: 1154m
Vario: +0.0%
DISMISS FOR 1 min
WAIT 2 0.0 1.0 862m

```

Example: altitude warning

2.1.2.5 SETUP GPS

UTC: A UTC offset can be entered at this option, thus ensuring that all time references are to local time rather than UTC. However, it should be remembered that any offset will have no effect on the time recorded in the IGC flight log; this will always be UTC

```

SETUP GPS
UTC: +00: 18:46:52
GPS EARTH DATUM:
WGS-1984

```

GPS EARTH DATUM: It is not possible to change the GPS earth datum. IGC regulations require that all flight recorders use the **WGS84** earth datum.

2.1.2.6 UNITS

All known units and combinations thereof can be programmed in the LX 7007 PRO IGC. The various units that can be selected are outlined below:

```

SETUP UNITS
LAT/LON D°MM.MM'
DIST. km SP. km/h
VARIO m/s HDG true
WIND km/h
ALT. m QNH mb
LOAD OVERLOAD

```

- LAT/LON: degrees and decimal minutes; or degrees, minutes and seconds
- DIST: kilometers (km); nautical miles (NM); or statute miles (mi)
- SP (Speed) kilometers per hour (km/h); knots (kts); or statute miles per hour (mph)
- VARIO: meters per second (m/s); or knots (kts)
- HDG: degrees magnetic (°M) or degrees true (°T)
- WIND: kilometers per hour (km/h); knots (kts); miles per hour (mph); or meters per second (m/s)
- ALTITUDE: meters (m); or feet (ft)
- QNH: millibars (mb); millimeters of mercury (mm); or inches of mercury (in)
- LOAD: Overload; kilograms per sq meter (kg/m²); or pounds per sq foot (lb/ft²)

$$\text{OVERLOAD} = \frac{\text{Glider} + \text{Pilot} + \text{Ballast}}{\text{Glider} + \text{Pilot}}$$

Example:

An overload of 1.2 means that the current ballasted flight weight is 20% higher than the unballasted flight weight.

2.1.2.7 GRAPHIC

The graphic display of the LX 7007 PRO IGC can show a lot of information and if it is all selected, the display can become very cluttered. This particularly applies to airspace information and the user should ensure that only relevant airspace is selected. It should also be remembered that a cluttered display also increases the load on the graphical processor and slows down the rate at which the screen is redrawn.

SETUP SYMBOL

The LX 7007 PRO IGC graphic display supports two sizes of glider symbol; large and small. Rotate the **UP/DOWN** selector to select the corresponding glider symbol. **TAIL LENGTH** enables a 'mouse droppings trail' to be configured that will display the achieved track for the last x minutes. The trail is disabled if the time period is set to zero.

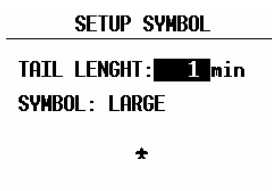
**AIRSPACE**

This setting allows the pilot to define which airspace types will be **shown on the display**. Each airspace type can be set to **ON**, **OFF** or a **ZOOM range** beyond which the particular airspace will not be displayed. Selecting **ON** will always show the airspace regardless of the ZOOM setting, and **OFF** will never show the airspace. If all airspace is set to **ON**, then at large ZOOM ranges, the screen becomes very cluttered and the graphics processor will become overloaded and slow down. To prevent this happening, the ZOOM range option allows a range to be set, beyond which the airspace will not be displayed.

SETUP AIRSPACE	
"A" 100_{km}	R,P,D 100 _{km}
"B" 50 _{km}	GLIDER 100 _{km}
"C" 100 _{km}	TMZ 50 _{km}
"D" 100 _{km}	MOA 50 _{km}
"E" 20 _{km}	AIRWAY 50 _{km}
CTR ON	OTHER 100 _{km}

Class A will only be shown when the **ZOOM** scale is 100km or lower

Note!:

If, for instance, 100 km is selected, then the airspace will only be shown when the **ZOOM** range is 100 km or lower. When the **ZOOM** range is greater than 100 km, the particular airspace **will not be shown**.

The LX7000 allows the following types of airspace to be shown:

- Class A
- Class B
- Class C
- Class D
- Class E
- CTR. Control zone
- R.P,D Restricted, Prohibited and Danger areas
- GLIDER
- TMZ Transponder mandatory zones
- MOA Military operating areas
- AIRWAY
- OTHER

Note!

CTRs are marked using a bold line, so the pilot is able to separate CTRs from other airspace very quickly.

Airspace Customization

A completely new feature of the LX 7007 pro IGC V2.0 is that pilots can customize their own airspace files. Pilots are able to create areas, or to add and remove particular airspace according to their personal requirements. All customization is done using the well known "**Open Air format**" or "**Tim Newport Piece format**". Detailed instructions on customization are described in a separate document, the **LxasBrowser manual**. This manual is supplied with each instrument and is also available on www.lxnavigation.si. Restricting the creation of airspace to a dedicated area where the pilot is usually flying will make the instrument much faster when operating the **ZOOM** function.

Note!:

All airspace files used with LX7000 v2.0 must have the **.CUB** extension; it is not possible to load old airspace format files. The new airspace files can be created and loaded using Lxe build July 15th 2003 or later.

Note!:

To be able to use all the benefits of the airspace graphics and warnings, it is recommended that some time is taken to study the airspace of the task area. All irrelevant zones should be deleted so that the speed of graphical presentation remains fast and unnecessary airspace warnings are avoided. Some TMAs are built from many sectors and is recommended that these sectors are amalgamated into one large TMA definition, if possible. After modification of **.LXW** files it is essential that a new **.CUB** file is built. **LXW** is a new airspace data base format described in the **LxasBrowser manual** or on the www.lxnavigation.si website.

APT GRAPHICS (Airports)

Airports are displayed with aerodrome symbols together with their name which can be configured in variety of ways.

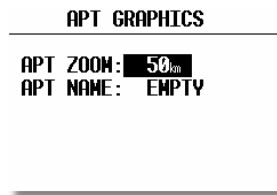

APT ZOOM: The airport zoom setting defines the **ZOOM** range under which the airports will be displayed. For instance, a 50 km setting will only show the airports when the selected **ZOOM** range is 50 km or lower; at greater **ZOOM** ranges, the airports will not be shown. The permitted settings are: ON, OFF, 5, 10, 20, 50 and 100 km.

APT NAME: The airports are displayed by an airport symbol with the adjacent name or designator as selected below:

- **ICAO** will show ICAO code of the airport adjacent to the symbol
- **2 char, 3 char, 4 char, 8 char** will display the first 2, 3, 4 or 8 characters respectively of the airport name.
- **NONE**, displays only the symbol with no code or name

TP GRAPHICS

The same logic is used for displaying turn points except that some further choices are available.

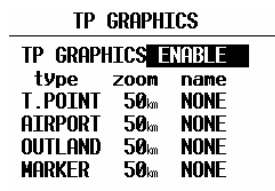

There are four types of turn points, and each type is designated by a different symbol on the screen (see para 3.2.2).

- **T. POINT** This is simply a turn point at which it is not possible to land
- **AIRPORT** This is an airport used as a turn point
- **OUTLAND** This is a turn point at which an outlanding is possible
- **MARKER** This is used to designate a temporary point, such as a good thermal source. It is deleted when the instrument is switched off

Note!:

If a turn point is designated as **OUTLAND**, then it will also be displayed in the **NEAR AIRPORT** screen with the corresponding symbol. (See para 3.2.2)

2.1.2.8 EDIT PILOTS (Pilot list)

The LX 7007 PRO IGC has the capability of storing up to 30 pilots names, each with their specific configuration preferences. The list is active as soon as the first pilot has been entered under **FLIGHT INFO** and copied into the pilot list. (see para 3.1.1.2 - **FLIGHT INFO** and para 3.4.1)

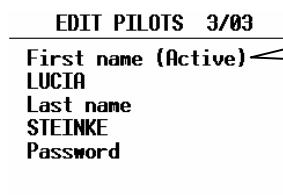

Advises that this pilot is active and his configuration is selected

Each pilot has the capability, if needed, of protecting his configuration by means of a personal password. This ensures that a particular pilot's configuration cannot be selected and altered by another pilot. If no pilot's name has been programmed, then **UNKNOWN** will be displayed and the settings made during the last flight will be recalled.

The following parameters are retained and stored with individual pilot's names:

- Final glide: RESERVE (safety) height
- Flight Info
- Settings under LOGGER
- INIT
- DISPLAY

Parameters stored with the configuration password:

- TP
- OBSERVATION ZONES
- GPS
- UNITS
- GRAPHIC
- NMEA
- PC
- POLAR
- LOAD
- TE COMP.
- AUDIO
- INPUT
- LCD INDICATOR
- PAGE 1
- PAGE 3

New pilots can be added and existing pilots edited simply by pressing **ENTER** in the following screen:

EDIT PILOTS 3/03	
First name (Active)	
LUCIA	
Last name	
STEINKE	
Password	
	EDIT
	INSERT
	DELETE

The caption **INSERT** allows new pilots to be added up to a maximum of 30. The label **Active** in the first line means that the pilot name shown has been selected during the initialisation and that his individual parameters are set.

Note!:

If a new pilot has been entered, or it is required to select a different pilot, then this can only be done by turning the instrument **OFF** and then **ON** again, and then selecting the new pilot in the initialisation screen **FLIGHT SETUP - FLIGHT INFO** (see Para 3.1.1.2)

2.1.2.9 SETUP NMEA

The LX 7007 PRO IGC is capable of outputting positional data sentences in the NMEA format for use by other devices. The various output configurations are shown below and by placing the cursor on any one and pressing **ENTER**, the individual NMEA sentences will be displayed. If Winpilot is used, then **WINPILOT** should be selected in this option.



2.1.2.10 SETUP PC

The baud rate (speed) of data transfer between the LX 7007 PRO IGC and other devices (PC, LX 20 or Colibri) is selected from this menu. The default is 19200bps. It is very important that both devices are set to the **same communication speed**.



2.1.2.11 DEL TP/TSK

This option allows all programmed turn points and tasks to be globally deleted. If **Y** (Yes) is selected, then all turn points and tasks will be deleted and cannot be retrieved. **Be careful with this option.**

2.1.2.12 GLIDER POLAR

Polars for most gliders are in the library. They are selected by simply rotating the **UP/DOWN** selector

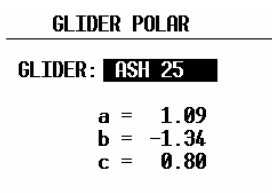

The polars are defined as a quadratic notation with the parameters a, b, and c. If a suitable polar is not found in the library, or it is required to define a **USER** polar, then the program POLAR.EXE, which is contained on the CD accompanying every instrument, should be executed. The program requires that 3 points on the new polar are entered at selected speeds (eg. 100 km/h, 130 km/h, and 150 km/h). The program will then calculate the values of a, b and c which should be noted and entered into one of the two **USER** polars (rotate **UP/DOWN** anti-clockwise). Finally, the name 'USER' should be replaced with a selected polar name as it subsequently appears as the glider type in the IGC recorder file.

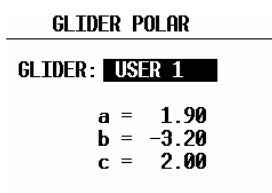

2.1.2.13 LOAD

Each time the instrument is powered up, the ballast settings are set to the minimum. By setting the SWITCH ON LOAD: SET, the ballast setting will remain at the last setting made on the previous flight and will not be zeroed on instrument power up.

2.1.2.14 SETUP TE COMP.

The LX 7007 PRO IGC offers two methods of vario TE compensation.

- TE tube
- Electronic TE compensation

Note!:

It is important to note that the method of TE compensation is set up when the instrument is installed by the pneumatic connections made to the TE and Static ports. Changing the compensation type in the setup screen below **WILL NOT** change the method of compensation - the pneumatic plumbing has to be changed first (see Chapter 5 - Installation).

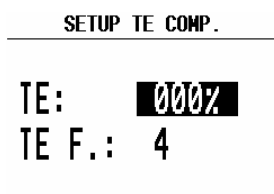

If the TE tube option has been installed, then TE: should be set to 0%

There is no further adjustment of the TE possible; the quality of the TE tube is the only factor.

If the Electronic TE option has been installed, then TE: should be set to 100%

The TE compensation can be fine tuned during flight with the following procedure. It is essential that this is only done in smooth air; it is not possible to tune the TE accurately when it is thermic.

- Select 100 % and default TEF
- Accelerate up to approximately 160 km/h (75 kts) and keep the speed stable for a few seconds
- Gently reduce the speed to 80 km/h (45 kts)

Observe the vario indicator during the maneuver. At 160 km/h the vario will indicate about about -2 m/s (-4 kts). During the speed reduction the vario should move towards zero and should never exceed zero (slightly positive indications are acceptable). If the vario shows a climb, then the compensation is too low, increase the TE%; and vice versa. Try another zoomie to assess the change and make further adjustments if necessary.

The TEF (TE filter) is the compensation delay. Larger numbers will increase the delay and vice versa. During the first test is recommended to use TEF 4.

Electronic TE is only effective when the pitot and static sources are co-located and the pneumatic lines to the instrument are approximately the same length. The best sensor to use is the combined pitot/static Prandtl tube. If problems are experienced with the electronic TE compensation, then the most likely cause is the glider's static source. The static source can be checked by plumbing the pneumatic tubes for electronic compensation and then setting the TE: to 0%. In still air, accelerate to approximately 160 km/h and slowly reduce the speed. Observe the vario indicator. If the static source is good, then the vario should immediately start to move to show a climb. If the needle firstly shows increased sink and then moves to a climb, the static source of the glider is unsuitable and there is no way to provide successful TE compensation electronically. The use of a dedicated and accurate fin mounted pitot/static source such as a Prandtl tube might help.

2.1.2.15 SETUP INPUT

The LX 7007 PRO IGC has an input for an external speed command switch. Using the external switch it is possible to switch between SC and Vario manually. Setting the **SC INPUT** to **ON** means that closing the switch will cause the instrument to enter SC mode, and setting **SC INPUT** to **OFF** means that closing the switch will select Vario mode. There is a third option by setting SC INPUT to **TASTER** and connecting a push button to the input, each key press will toggle between SC and Vario.

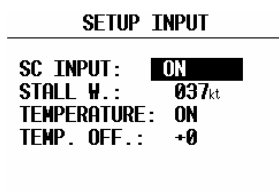

An external alarm to supplement stall warning can be connected to the LX 7007 PRO IGC. The indicated airspeed at and below which the alarm will operate is set under **STALL W.**. This is also useful in a glider that becomes very 'draggy' at less than the optimum thermalling speed, such as the LS8. Setting **STALL W.** speed to coincide with the onset of the drag bucket will enable optimum thermalling speed to be maintained.

The LX 7007 PRO IGC is supplied with an external temperature sensor. Selecting **TEMP. ON** will enable temperature measurement by the sensor. Setting **TEMP. OFF** permits the user to enter the temperature reading.

There is another input called **VARIO PRIORITY**. When this input is activated by grounding the appropriate wire, the unit will change over to Vario immediately. This input wire is set open (not grounded) as a factory default on delivery.

2.1.2.16 SETUP LCD INDICATOR (LCD – Vario Indicator)

The LCD vario indicator is a part of LX 7007 AU. Unlimited number of secondary vario indicators can be connected to the system using the 485 system bus. The LX 7007 PRO IGC provides 4 different sets of data that can be displayed on the vario indicators. This means that up to **4 indicators can be set to display different information**; any further connected indicators are simple repeaters. Each LCD indicator is set up from the following menu:

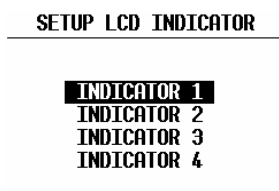

An LCD vario indicator consists of:

- Needle
- Two numerical displays (upper and lower)
- Labels and indicators

These following functions can be set (see next picture):

- | | |
|-------------------------|--|
| • Needle | Vario needle (Vario, SC, Netto or Relative) |
| • SC Ring | Displays speed command at all times |
| • Upper Numeric Display | Upper line, the parameter displayed can be configured in both Vario and SC modes |
| • Vario Mode Indicator | Shows current flight mode (vario or speed command) |
| • Lower Numeric Display | Lower line, the parameter displayed can be configured in both Vario and SC modes |

The labels will automatically be displayed depending on the current function. The **BAT** warning will be displayed when the supply voltage is below 11 volts.

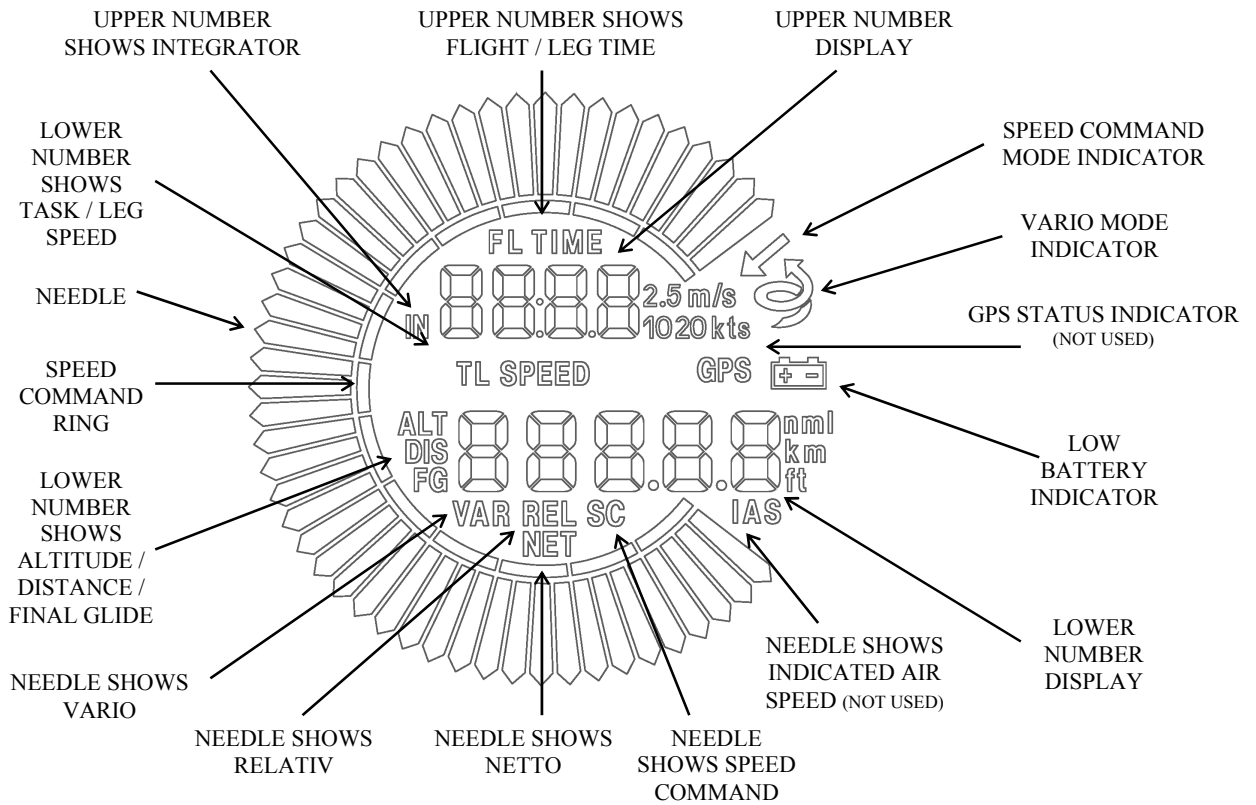

The vario indicator built into the LX 7007 AU is always **Indicator 1**(no settings possible).

Each further indicator has a **DIP switch on the rear side** that sets and identifies the indicator and enables it to be programmed under that identification. The positions of the switches are listed below.

SW 1 ON	Indicator 1
SW 2 ON	Indicator2
SW 3 ON	Indicator3
All OFF	Indicator4

After identification, the needle and the two numerical displays of each indicator can be programmed to display the following parameters:

LCD INDICATOR 1	
VAR. NEEDLE:	VARIO
SC NEEDLE:	SC
VAR. U. NUM.:	INT.
SC U. NUM.:	INT.
VAR. L. NUM.:	ALT.
SC L. NUM.:	DIST.

All settings should be made for vario and speed command mode separately (e.g.: VAR NEEDLE =needle in vario mode, SC NEEDLE = needle in SC mode).

Needle settings:

- Vario, SC, NETTO or RELATIVE (= netto – 0.7 m/s),

Upper numerical line:

- Integrator, time, flight time, leg time

Lower numerical line:

- ALT (NN altitude), distance, GL DIF. (final glide altitude difference), SPEED (TAS), LEG S. (speed on leg).

2.1.2.17 COMPASS

This unit is an optional extra. The compass module is connected by the 485 bus to the LX 7007 PRO IGC. If the compass is connected, this setting enables the compass to be calibrated and is described in Chapter 7. If a compass module is not connected, the COMPASS setting is not active.

2.1.2.18 ENL (Engine Noise Level)

This page shows the current ENL reading to confirm that it is operating correctly. No adjustment is possible.

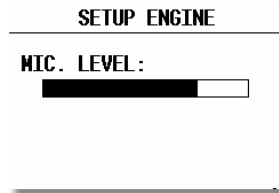

2.1.2.19 PAGE 1 (Main Navigation Page)

There is a choice of three variants of the layout of this page. The three pages are shown below; the third variant being the default:

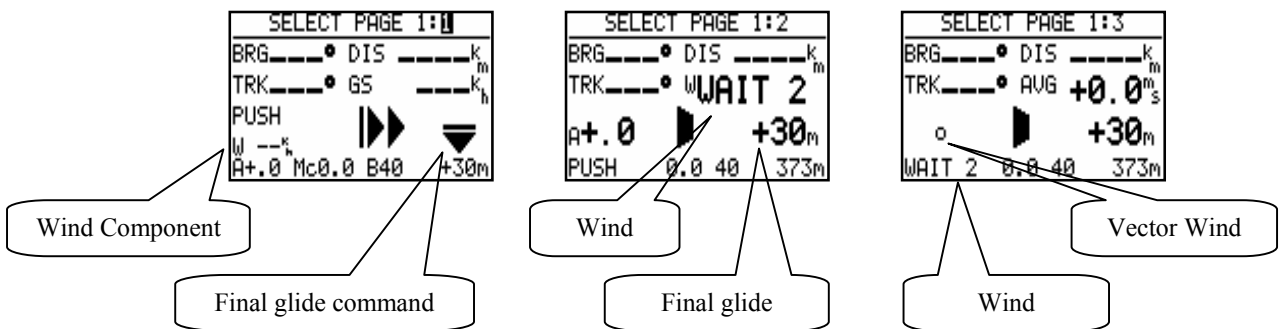

Variant 3 will bring useable information in SC, actual glide ratio and the minimum glide ratio to reach the point.

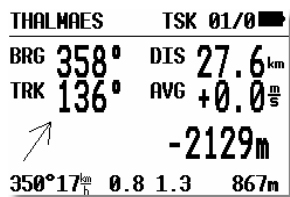

Vario

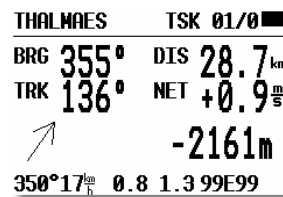

SC

Actual and min glide ratio to reach finish, TP or APT

2.1.2.20 PAGE 3 (Additional Navigation Page)

This page can only be activated or disabled. Default set is ON.

2.1.2.21 SETUP AUDIO

A wide variety of audio tones can be configured:

SETUP AUDIO	
SC: VOL H	SC
VARIO:	LIN/POS
0%:	0500Hz
+100%:	1500Hz
-100%:	0200Hz
AUDIO-DEMO!	

- SC: VOL H audio volume will be increased by speed command (H) or decrease by (L)
- VARIO: Several types of audio can be selected (use AUDIO DEMO to hear the choices available)
- 0% Tone frequency at 0 m/s
- +100% Tone frequency at full + deflection
- -100% Tone frequency at full - deflection

2.1.2.22 SETUP ALARMS

The unit produces an audio alarm on reaching certain confirmation points. This screen allows the parameters of the audio to be configured.

SETUP ALARMS	
F1: 3000Hz	F2: 2000Hz
T1: 0300ms	T2: 0300ms
No. PERIODS: 10	
NEXT ALARM : 3min	
ALARM TEST	

2.2 Navigation Functions

The LX 7007 PRO IGC has the following navigation functions displayed on six main pages. The pages are selected in sequence by rotating the **MODE** selector:

- **GPS** - Status and Coordinates
- **NEAR AIRPORT**
- **APT**, - Airport
- **TP** - Turn points
- **TSK** - Tasks
- **STATISTICS** - These can be accessed both during flight and after flight using the LOGBOOK function

2.2.1 GPS Page

This page is purely informative; no configuration is possible.

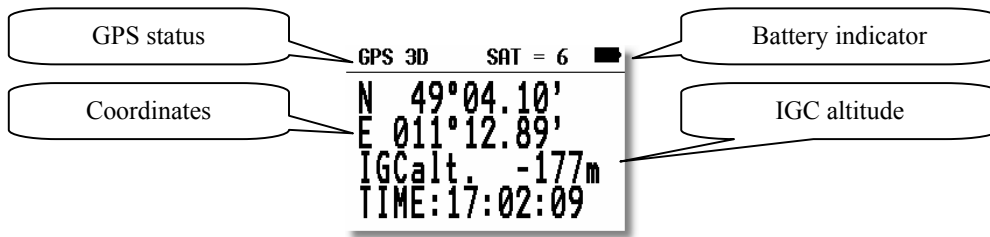

By rotating the **UP/DOWN** selector the displayed altitude will appear in both m and ft at the same time.

The **TIME** display can be changed to a Stop watch as follows:

- Press **START** status **STOP:** 0:00
- Press **START** status **RUN:** 0:12
- Press **START** status **STOP:** 0:50
- Press **START** status **STOP:** 0:00 Reset
- Press **ENTER** and **TIME:** 11:56:32 is re-activated

2.2.2 NEAR AIRPORT

This option displays the nearest airports, both from the APT database and the TP list, together with those turn points that have been selected as being landable. The airports are sorted by distance with the closest first. Simply place the cursor with the **UP/DOWN** selector on the desired airport and press **ENTER**. The LX 7007 PRO IGC will change to APT mode and all navigational features will be available.

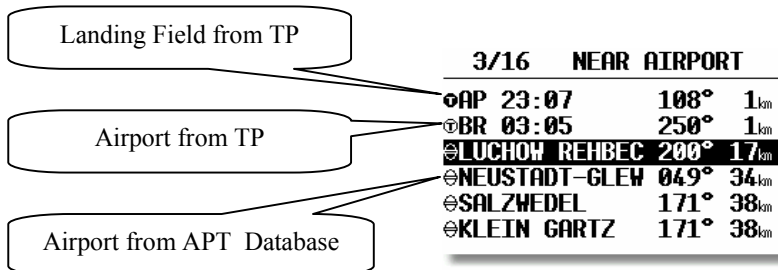

Note!:

The symbol preceding the name indicates which database the landing point has come from. See the examples above.

2.2.3 APT Airports, TP Turn Points and TSK Tasks

The three main navigation modes (APT, TP, TSK) are selected by rotating the **MODE** selector. All three options are similar and have similar basic navigation data screens accessed by turning the **UP/DOWN** selector. The first page shows the basic navigation data (bearing, distance, ground track and ground speed). The airport memory of LX 7007 PRO IGC has a capacity for approximately 5000 airports. The airport data cannot be edited in the instrument; all necessary updates should be done using a PC. The database used in LX 7007 PRO IGC is a free database. The database can be downloaded from the Internet using the following addresses:

www.lxnavigation.si

2.2.3.1 Navigation in APT, TP or TSK

There are five navigation pages; the first one is described below.

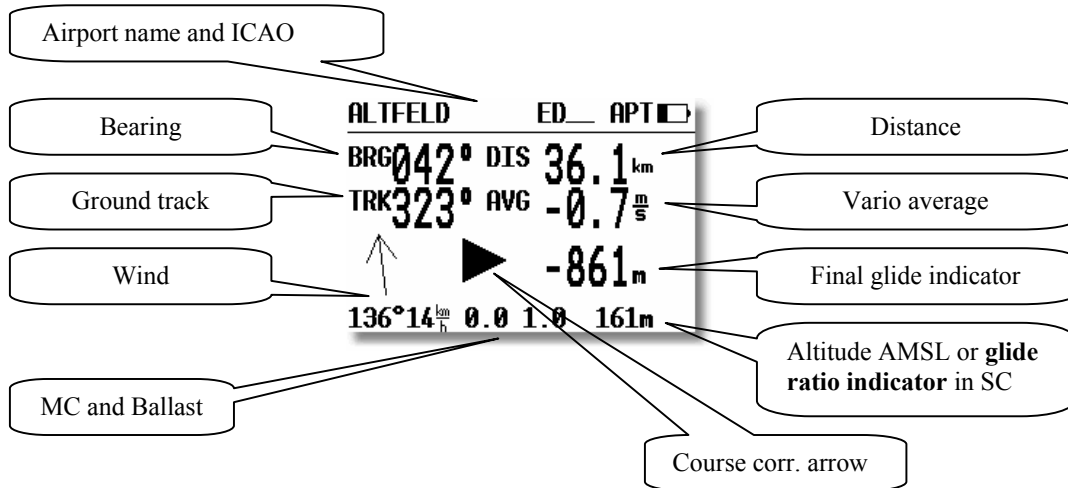

Note!:

The glide ratio indicator consists of two numbers separated with an E (43E77). The left figures show the average glide ratio achieved during the last two minutes, while the right figures show the minimum glide ratio required to reach the APT, TP or finish the task. The over-range indication is '99', which means that the glide ratio is in excess of 99:1. When **flying a task**, the minimum glide ratio is calculated on the total distance to the finish line, including all uncompleted TPs, and any preset safety altitude. This function is very useful when the final glide is being set up around one or more TPs

The Airport and TP names are normally displayed using 8 characters, but by pressing the **START** button, 12 characters will momentarily be displayed. The course correction arrow (Direction Indicator) shows which way to turn (left or right) to reach the desired APT or TP.

Rotating the **UP/DOWN** selector will bring up the graphic page. The airports will be shown with both symbols and short names or ICAO-code. (see para 3.1.2)

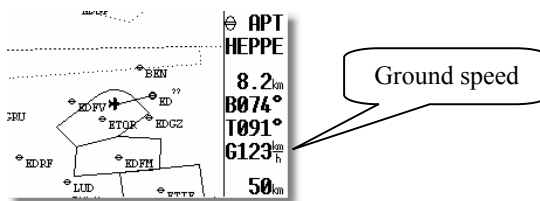

The glider symbol remains in the centre of the screen and the map moves under it. To change the displayed range, simply rotate the **ZOOM** knob anti-clockwise to increase the range or clockwise to decrease it.

The third navigation page which includes a course deviation indicator (CDI) can be disabled in setup under the **PAGE 3** option.

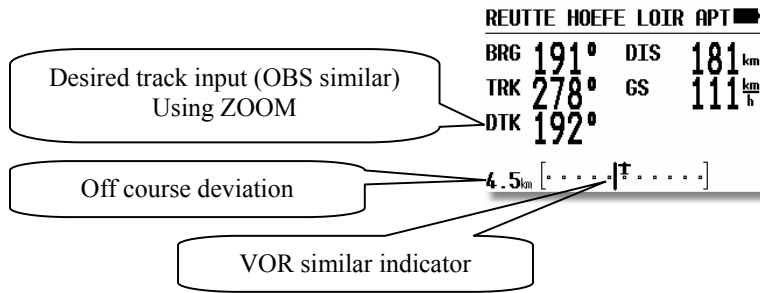

Further rotation of the UP/DOWN selector will call up the fourth, or arrival page.

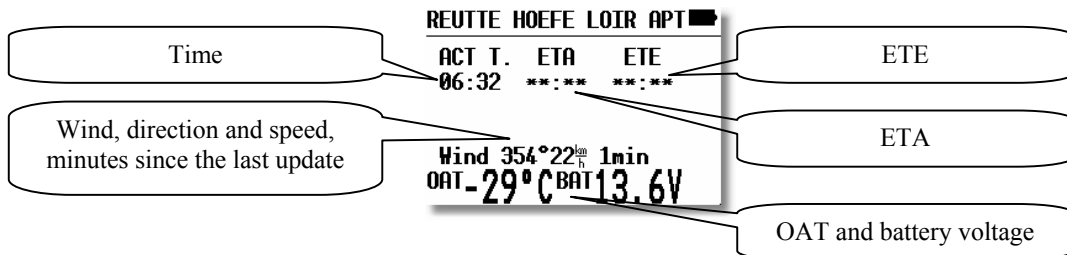

ETA (estimated time of arrival) and ETE (estimated time enroute) define the arrival time and the time needed to reach the destination. Both depend on the settings in the INIT menu. If the glider is not tracking in the direction of the selected point (track and bearing differ more than 90°), both times will be replaced with stars. The age of the last wind update in min is displayed after the wind vector. Continued rotation of the UP/DOWN selector will show the last page, where details of the selected airport will be displayed.

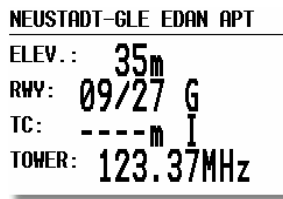

The data is self explanatory except for the traffic circuit, TC details. The pattern height together with its orientation (N or S) is displayed. The letter I means that the pattern details are not defined.

2.2.3.2 Airport Selection, Team and Wind Calculation

After placing the cursor on the function required and pressing ENTER, a menu appears which offers airport selection, the team function, or selection of the method of wind calculation.

2.2.3.2.1 SELECT - Airport Selection



There are two ways to select an airport. If the ICAO locator is known, it can be directly entered when the name of the airport will be displayed.

```

APT SELECT
-----
ICAO: EDDM
      GERMANY

MUNICH

```

If an incorrect letter is entered, then either press **START** or rotate the **ZOOM** selector to move the cursor back so that the letter can be re-entered.

If the ICAO locator is unknown, then the following method should be used. With the cursor on **ICAO**, press **ESC** to move the cursor to the country. Select the required country with the **UP/DOWN** selector and press **ENTER**. Four stars will now be displayed at the airport name. Using the **UP/DOWN** selector and **ENTER**, input the first four letters of the airport name. All airports with the same first four letters will be available and can be cycled through by use of the **UP/DOWN**.

```

APT SELECT
-----
ICAO: EDBM
      GERMANY
APT: M***

```

If you input less than four characters, the number of airports that fit the first x letters will be greater. If all four stars are confirmed with **ENTER** or after pressing **ESC**, all airports of the selected state are available and can be cycled through in alphabetical order.

2.2.3.2.2 TEAM function

This special function has been developed to help pilots flying in a team to locate each other if they lose visual contact. Both pilots have to select the same destination point (APT, TP or TSK). One pilot then passes his range and bearing to the selected point by radio. The second pilot then selects **TEAM FUNCTION** and enters the range and bearing passed by the first pilot.

```

TP TEAM
-----
BRG: 347°
DIS: 24.1 km
TO PINNOW

```

Input

```

TP TEAM TP
-----
BRG349° DIS 10.0 km
TRK093° NET +0.0 m/s
○ -294m
WAIT 1 0.0 1.0 0m

```

Navigation toward companion

Example:

If 347° and 24.1 km is the range and bearing given by the first pilot. After entering the figures and pressing **ESC**, the instrument will change to the normal **TP navigation page** and the data will show the position of the first pilot.

The team function is deactivated **after a new APT or TP** is selected.

2.2.3.2.3 WIND calculation

The LX 7007 PRO IGC is able to calculate the wind vector. This function is the same in all three navigation modes. A further method, **COMPASS**, is available only after an optional compass unit is connected to the LX 7007 PRO IGC RS485-bus. To change the method of wind calculation, use the following menu:

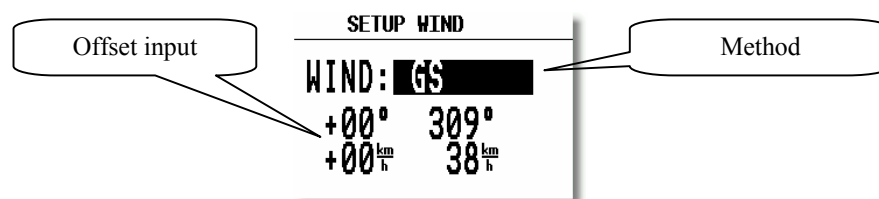

GSPEED DIF. is the simplest method. The calculation is based on measuring ground speed changes while **circling**. A minimum of two full circles are necessary to obtain an accurate wind. The message **WAIT2** or **WAIT 1** informs the pilot how many circles are left to get the result. It is very important to **keep the speed constant** while circling to ensure that accurate results are obtained. The pilot is able to adjust the wind using manual corrections through the Offset Input.

POS. DRIFT is the most accurate method. It is based on measuring the drift due to the wind during 6 full circles. These circles have to be flown accurately and at a constant speed to achieve the best results. **WAIT 6 to 1** indicates how many circles are left until a result is produced.

COMBINATION is using a combination of two methods:
-during the climbing a very reliable method GSPPED DIF. is used and during straight flight an algorithm which calculates wind after input of GS,GTand TAS. The change over between methods is done automatically.

COMPONENT calculates the **wind component** (head or tail wind). The calculation is based on measuring the difference between GS and TAS during straight flight.

FIXED VALUE is not a calculation; it simply allows the pilot to input the wind vector that he wants to use.

COMPASS wind calculation method is available only with the optional compass device. Its use is described in the COMPASS manual.

2.2.4 TP - Turn Points

The LX 7007 PRO IGC has the memory capacity to store up to 600 turn points. The turn point name can have a maximum of 8 characters (letters or numbers, no lower case letters and no special signs except * and _). The menu structure is the same as in the APT menu - either four or five pages depending on the set up parameters. A turn point can be added to the database in one of four ways:

- Manual input
- Copy from APT database
- Data transfer from a PC, LX20 or Colibri (*.DA4 format)
- Input of actual present position

The procedure is similar to the method of selecting an APT. While in any TP page, press **ENTER** and a menu showing **SELECT, EDIT, NEW, DELETE, TEAM** and **WIND** will be presented.

2.2.4.1 TP SELECT

To select a turn point simply replace the stars with the first letters of the TP.

IMPORTANT!

The LX 7007 PRO IGC is able to sort the turn points alphabetically or by distance from present position. The method used is defined in the setup menu. The default setting is alphabetic. If sorting by distance is selected, then the **nearest TP** will appear after selection (**all stars confirmed with ESC**). To search for the TP use **UP/DOWN** selector and confirm with **ENTER**.

It is also possible to select TP by using **ZOOM** selector. This works exclusively from **the first page**. To change the TP simply rotate the **ZOOM** selector.

2.2.4.2 TP EDIT

This option allows the pilot to change TP data at any time. The turn points used in LX 7007 PRO IGC have four attributes. Using attributes, when the turn points are displayed in graphic pages, they will be represented by different symbols. The four different types of turn points are as follows:

- **T.POINT** normal TP, not landable
- **AIRFIELD** landable airfield
- **OUTLAND** landable outlanding place
- **MARKER** temporary marker which will be deleted when the instrument is switched OFF

TPs having an **airport or outland attribute are landable** and are shown on the NEAR AIRPORT page. In front of the name the pilot will see a symbol indicating what kind of landing place it is (see NEAR).

To start **EDIT** press **ENTER**.

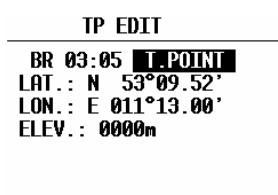

Name, attribute, coordinates and elevation can be changed at any time.

2.2.4.3 TP NEW

Place cursor on **NEW** and press **ENTER**. The following window will be displayed.



'Y' allows a new turn point to be copied from the **APT** database. If it is required to enter a completely new turn point, then select 'N'. A second menu will then be displayed allowing the name, co-ordinates, attributes and elevation of the new turn point to be entered.

2.2.4.4 TP delete

If this option is selected, then delete confirmation will be requested. If the reply is 'Y', then the turn point will be deleted and cannot be recovered.

2.2.4.5 TEAM

This function is the same as described under APT in para 3.2.3.2.2

2.2.4.6 WIND

This function is the same as described under APT in para 3.2.3.2.3

2.2.4.7 TP QUICK - Storing of actual position

The procedure is activated by pressing the **START** button while **in the TP-main page only !**

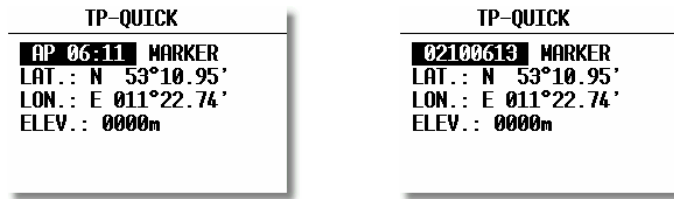

On activating the procedure, the present position is displayed with the name defined in one of two forms; **AP** (actual position), or **TIME** (date and time), depending on which option has been selected in the setup (through password) menu. Once selected, the data can be edited if required. This procedure is useful to store convenient landing places noted during flight, thermals etc. By default, these points are designated with the **MARKER** attribute and are therefore deleted when the instrument is switched off. If these points are required to be stored for future use, then the attribute should be changed before switching off.

2.2.5 TSK - Task

The LX 7007 PRO IGC can store up to 100 tasks, with each task containing a maximum of 10 turn points (start , 8 turn points and finish). Selecting and storing a task confers the following benefits:

- Accurate task statistics
- Simpler navigation
- Automatic change over to next TP after confirmation
- TSK shown on the graphic display
- One further step of **ZOOM** (full task)
- Full AAT support (Assigned Area Task)

Note!:

The final glide calculation in TSK mode is calculated from the present position to the finish point, via all uncompleted turn points. Final glide to a single turn point or airport is available in the TP or APT modes.

The menu structure is similar to the APT and TP. Graphical data about the start, TP confirmation and finish line is particularly useful.

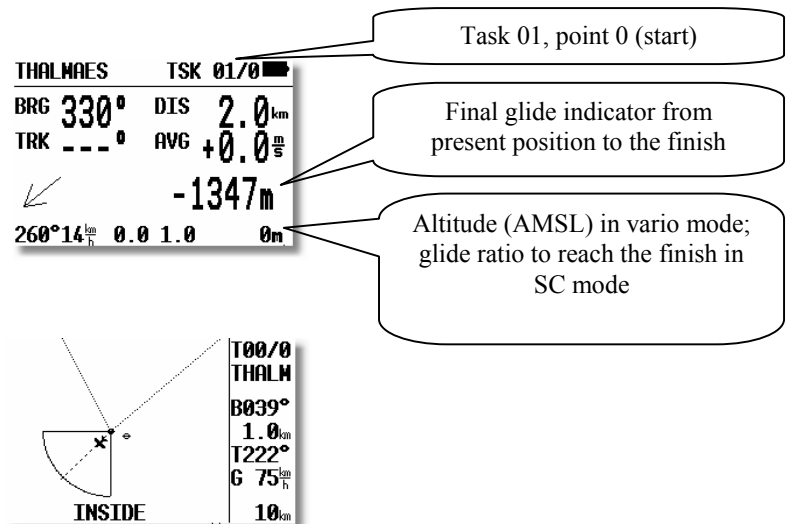

When approaching a TP, a **NEAR** message is displayed to inform the pilot that he is closing on the turn point. When the glider enters the observation zone, then the message **INSIDE** is displayed.

The tasks are numbered from 00 to 99 and the turn points building a task numbered from 0 to 9. Point 0 is always the start point.

2.2.5.1 TSK - SELECT

All stored tasks can be viewed by choosing **SELECT** and pressing **ENTER**. All pre-programmed tasks can now be viewed by rotating the **UP/DOWN** selector; once the required task is displayed, it is selected with **ENTER**.

Note!:

Using the **ZOOM** knob is possible to select tasks by simply **rotating** the knob. This function is active only from the **main navigation page**. After each selection, the total task distance is shown for a short time to help to decide which task to choose. The total task distance displayed is the sum of the length of all the task legs, **plus** any additional distance to reach the start point.

```

MATKOPUS      TSK 01/0
BRG 360°     TOT 427 km
TRK ---°     AVG +0.0 m/s
              -8021m
WAIT 2  0.0 1.0 239m
    
```

Total distance for apr. 2 sec.

2.2.5.2 TSK - EDIT

The active TSK can be edited at any time, both on the ground and during flight. An already **overflowed** turn point cannot be edited.

```

TSK EDIT      TSK 01
44.4 km Time: 01:00
0 THALMAES 18.3 km 336°
1 ROTH ROT 26.1 km 073°
2 NEUMARKT
3 NOT PROG
4 NOT PROG
    
```

Expected time to complete TSK

The expected time to complete the task is entered in hours and minutes. While this input is not obligatory, doing so will allow progress to be monitored during an AAT which normally requires to be completed within a specific time window. Once the task is started, this time runs toward zero and the extended ETA/ETE page will show a lot of additional information (see flying LX 7007 pro IGC). After a task has been started no input is allowed.

If a turn point is to be inserted, changed or deleted, the desired turn point is selected with the **UP/DOWN** selector and on pressing **ENTER**, a sub menu opens up:

```

TSK EDIT      TSK 01
44.4 km Ti
0 THALMAES
1 ROTH ROT
2 NEUMARKT
3 NOT PROG
4 NOT PROG
SELECT
INSERT
DELETE
ZONE
MOVE
    
```

- **SELECT** replaces the selected turn point with another
- **INSERT** adds a turn point above the one selected
- **DELETE** removes that turn point from the task
- **ZONE** and **MOVE** relate to AAT (see below)

Assigned Area Tasks (AAT) - Special Functions

Up to five tasks of the 100 programmable (from 00 to 99) can be designated as AAT. Each individual task point can be configured for an AAT by using **ZONE** and **MOVE**. If **ZONE** and **MOVE** do not appear on the sub menu, then five

tasks are already modified for AAT. The AAT modified tasks are active **for three flights only**. After the third flight all sectors are set back to the default settings (as defined in **SETUP/OBS.ZONES**). This feature allows the competition pilot to make three take offs without loosing the AAT information.

- **ZONE-** Using this function, an individual sector can be defined for each turn point of the task. In the following example TP 0, the start sector at Thalmaes is defined

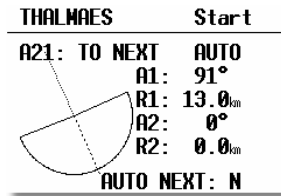

A21, A1, A2, R1 and R2 have the same meaning described in **SETUP/OBS. ZONES** (Para 3.1.2.2)

The final option. AUTO NEXT defines what happens after reaching the programmed zone. When flying “normal” speed tasks, with AUTO NEXT set to Y (Yes), the LX 7007 PRO IGC will change over to next turn point immediately after a fix is recorded in the sector. In an AAT this is not very useful, because of big sectors and the need to use the MOVE function. Setting the AUTO NEXT to N (No) prevents the LX 7007 PRO IGC from switching to the next turn point when reaching the sector. The pilot must switch over manually by making a short press of the **START** button. In the example below an individual sector with 60° has been set at the first turn point and the automatic switch over disabled.

Example:
Selecting R1 more than 10 km, will set **AUTO N** automatically.

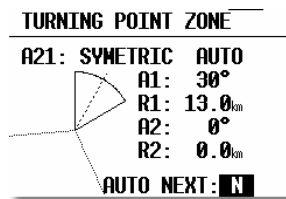

Start is default N, the TP will automatically change to N after **MOVE** function is activated.

Note!:
Editing a task and the corresponding sectors can also be done during flight. (See 'Flying with the LX 7007 PRO IGC' Para 3.4)

- **MOVE** In an AAT the sectors are generally quite large, therefore it is reasonable to consider modifying the task during flight. All AAT's (max. 5, see above) offer this possibility. Moving of the turn points is allowed inside the sector only.

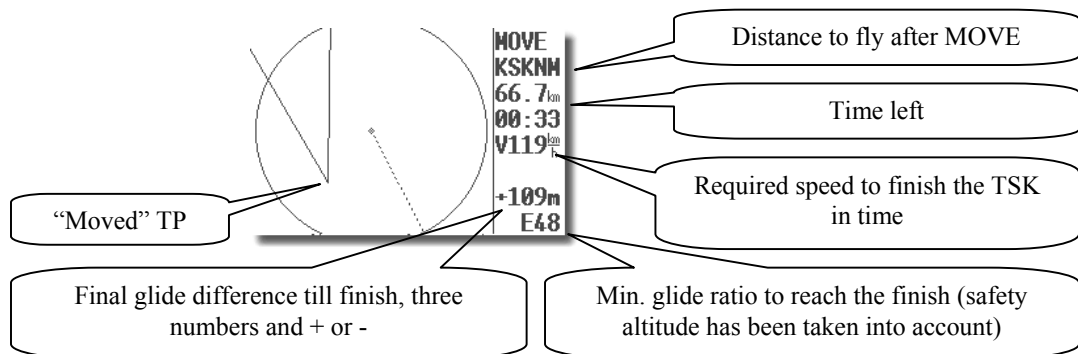

Having used MOVE-function, the “new” point has a '#' as the first character (very significant). The sector and the reference point stay unchanged, but all navigation data is modified corresponding to the new (virtual) point. For example, the final glide is now calculated around the new point, and the statistics are modified in the same way.

The point is moved using the rotary knobs **UP/DOWN** (vertical) and **ZOOM** (horizontal). It is not possible to **MOVE** outside the sector. Unless a specified task time (task edit) has been entered, the required speed and remaining time to complete the task will **not be displayed**.

The extended arrival page offers the following information:

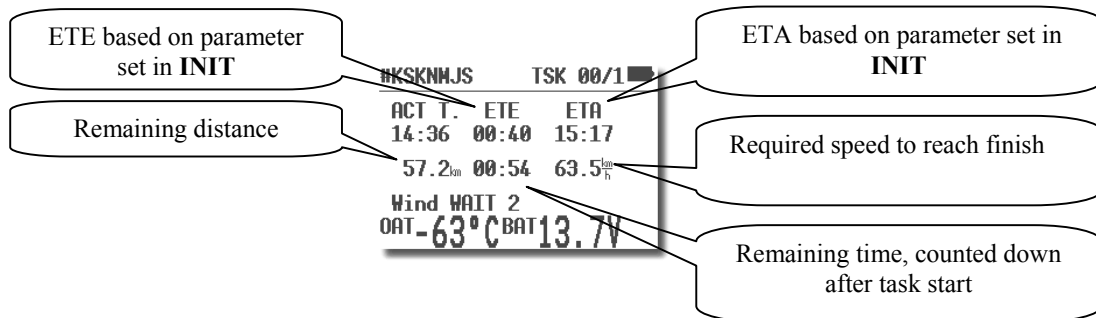

The **remaining distance** is the distance from actual position to the finish line. (If the task has not yet been started, then this distance includes the distance from the present position to reach the start)

The **remaining time** is the time left to finish the task, simple count down after task start (active only after input TIME in TSK edit).

The **required average speed** is calculated from remaining distance and the remaining time.

Note!:

ETA and ETE are calculated using the parameters defined in **INIT** under ETA. This is important for competition pilots. By pressing **ESC**, the ETA and ETE calculated up to actual TP are displayed for 3 seconds

2.2.5.3 TSK - NEW

Pressing **ENTER** with the cursor on **NEW** will select a sub menu asking whether an existing task should be copied. If **N** is selected, then the next available task with all points un-programmed will be selected. Sometimes it is easier to copy an existing task and then amend it; pressing 'Y' allows this to be done.

2.2.5.4 TSK - DECLARE

For all FAI flights (badges, records, and decentralized competitions) the task should be declared before take off. This procedure replaces the requirement to make a written or photographic declaration.

Note!:

The declaration will not change the instrument functions. The declaration is only the procedure to show that the flight was planned and declared before take off. All manipulation and functions of the LX 7007 PRO IGC will be the same whether the task is declared or not. The only difference is in flight validation is that the declaration is recorded in the .IGC file. **Redeclaration during the flight is not possible**. Editing the task during the flight, or fly another task will **not change the declaration**.

Pressing **ENTER** with the cursor on **DECLARE** will display the following sub menu:

TSK DECLARE			
Dist.: 163.5km			
0	THALMAES	TAKE OFF	
1	THALMAES	63.1km	041°
2	094SULZB	23.8km	106°
3	087SCHMI	76.6km	238°
4	THALMAES		

All known methods (select, insert, and delete) can be used to change the declaration at this stage. **Changing of declaration will not change the TSK.** The take off and start points as well as finish and landing points will usually be the same. If these points are not identical in your task you have to change either start point or take off point as necessary.

The normal procedure for declaration is:

- Prepare **TSK** in **TSK/EDIT** menu (you will need it for navigation later).
- Press **ENTER** on **DECLARE**, check it is correct and then press **ESC** to make the declaration.
- A short **message** on the screen will then show the time and date of the declaration

Note!:

If the task declaration procedure has not been made before take off and a believable task has been flown, then an afterward declaration will be written into IGC file, such a declaration is **not valid for official IGC flights (time of declaration after landing)**, but can be used for pilot private flight evaluation. Only declarations made before the flight (manually or via flight info data transfer) will fulfill IGC requirements. A declaration will remain **active for one flight only** (power down will not delete the declaration).

2.2.6 STATISTICS

This mode is exclusively used to give the pilot information about his actual flight. There are two levels of statistics; flight statistics and task statistics. Flight statistics are active immediately after take off and task statistics are activated once a start is made. (see Para 3.4.4.7)

2.2.6.1 Statistics during flight

2.2.6.1.1 Flight statistics

The following page is visible during the flight and for a few minutes after landing, before the instrument switches to the 'Calculating Security' procedure.

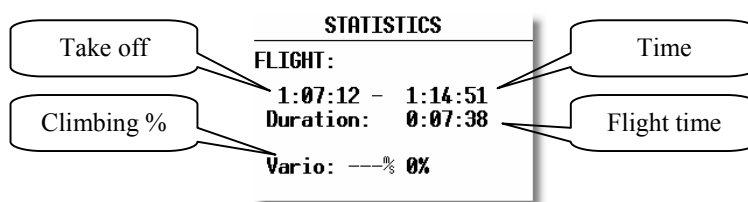

2.2.6.1.2 TSK Statistics

The following statistics are available after the task has been started. Rotation of the **UP/DOWN** selector permits scrolling through individual legs.

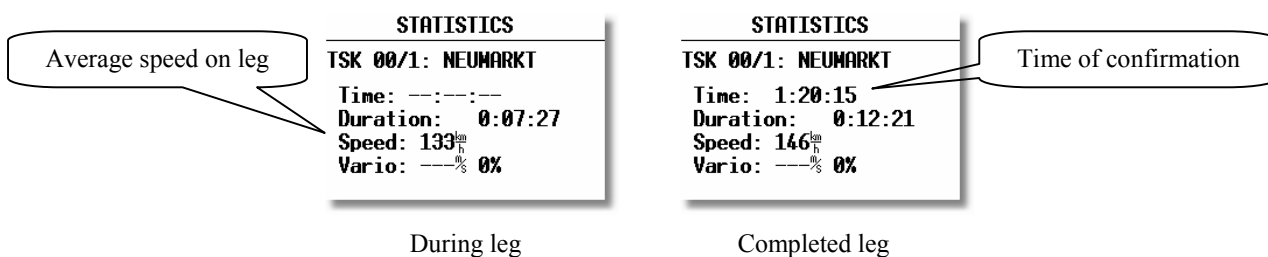

During an active task leg, the time will remain blank as it is the **TP confirmation time** and is never shown until the TP is confirmed. The completed leg display shows time turn made, the time spent completing the leg (**duration**), average speed on leg and % of time spent climbing. The last shown screen always shows the **task statistics** from the start to the current position.

2.2.6.2 Statistics after flight

2.2.6.2.1 LOGBOOK

These statistics are available **after flight**. The logbook shows the flights by date with take off and landing time. The logbook entry will appear approximately 3 minutes after landing and is the signal that the flight is finished and that the unit can be switched off.

LOGBOOK		
10.02.02	7:36	7:47
10.02.02	6:24	7:31
10.02.02	4:30	5:53
10.02.02	3:02	3:12
10.02.02	2:37	2:59
10.02.02	2:22	2:31

2.2.6.2.2 Statistics after flight

The LX 7007 PRO IGC provides post flight statistics and analysis. To start the procedure, select the flight from **LOGBOOK** and press **ENTER**.

Flight: 1	30.09.03
PILOT: UNKNOWN	
DURATION: 0:56:28	
14:27:11 - 15:23:39	
Dis.flown: 77.1 km	
Speed: 108 km/h	

The flown distance will appear if the unit has any task information (either a programmed TSK or a simple task - see para 3.4.4.7). If no task information is available, then the **TASK NOT SPECIFIED** message will appear. Speed is average speed on task.

After pressing **ENTER** the pilot is able to recall the route flown and barogram.

Flight: 2	12.06.02
PILOT: UNKNOWN	
GLIDER	ROUTE
DURATI	BAROGRAM
8:22:53 - 8:24:44	
TASK: NOT SPECIFIED	

- ROUTE - route flown will be shown

On pressing ENTER with the cursor on ROUTE, the display shows:

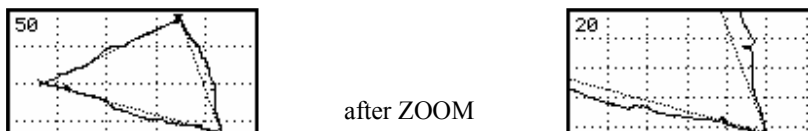

To program ZOOM, press ENTER and a small cross will appear in the middle of the screen. Move the cross by rotating ZOOM and the UP/DOWN selector. Press ENTER when the cross is positioned at the start of the area to be zoomed. Repeat the procedure for a second cross and place at the end of the area to be zoomed. Press ENTER and the expanded area will be displayed.

- BAROGRAM - barogram of the flight

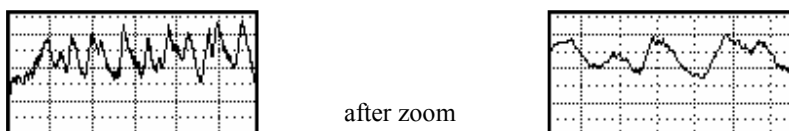

The zoom procedure is similar, but there is no cross. After pressing ENTER, a vertical bar will appear which can be moved (with UP/DOWN) and fixed with ENTER again. The same procedure is used to place the second bar.

2.3 Variometer and Altimeter

All signals from the pneumatic sensors (altitude, speed) are derived from high quality pressure sensors which means that no flask is necessary. The vario signal is derived from the altitude signal. All signals are temperature compensated while the vario and speed signals are altitude compensated as well. A custom programmable LCD has been designed to display the vario information as well as many other parameters. The display is user configurable.

The variometer can be configured to show:

- range 5,10 and 2.5 m/s 10,20 and 5 kts
- five time constants 1s to 5s, in addition there are 4 settings of electronic processing for the vario signal
- netto vario air mass lift and sink
- relative vario shows the lift or sink that would be achieved if the glider was circled at thermalling speed

There are two ways by which the vario indications can be corrected for total energy; electronic TE compensation based on speed changes with time; and pneumatic compensation with a TE tube. When using pneumatic compensation from a TE tube, the LX 7007 PRO IGC **does not process the signal in any way**. The quality of the TE compensation depends entirely on the location, size and dimension of the TE tube. The installation must be leak-proof.

Note!:

If electronic TE compensation is selected, then the TE port should be connected to a good static pressure source. If pneumatic compensation is selected, then the TE port should be connected to the TE tube.

2.3.1 Smart Vario description

The LX system incorporates two configurable electronic filters in the circuitry. The first filter adjusts the time constant and is adjustable between 0.5 and 5 seconds. The 0.5 setting is the fastest while the 5 setting provides maximum damping.

The second filter, called the Smart Vario, is a dynamic filter and controls the rate at which the vario indication moves. When set to OFF, there is no restriction on the rate of movement of the vario indication other than the setting of the time constant filter. When set to 1, the vario indication will not move faster than 1 m/s (2 kts) per second, while when set to 4, the vario indication will not move faster than 4 m/s (8kts) per second. It should be noted that when set to 4, the vario indication will move four times faster than when set to 1.

Summary:

- The Smart Vario should not be used in isolation but in conjunction with the setting of the time constant filter. When the Smart Vario is activated, the time constant filter may need further adjustment to provide optimum indications.

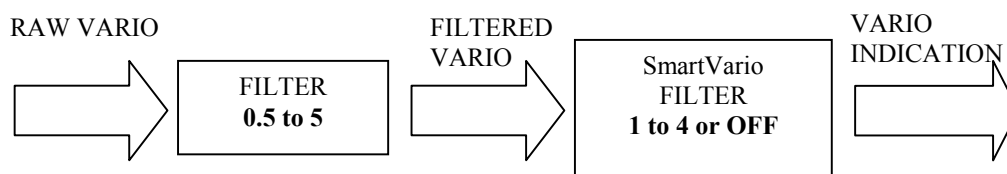

2.3.2 Altimeter

The altimeter of LX 7007 PRO IGC is temperature compensated from -20°C up to + 60°C. The altimeter is calibrated from 0 to 6000m (20,000ft), but indication goes up to 8000m (26,000ft). The displayed altitude can be based on the airfield elevation (QFE) or the local QNH which is set in the initialization screen after switching on.

2.3.2.1 IGC barogram recalibration procedure

LX 7007 PRO IGC has an **additional pressure sensor** for altitude recording. To comply with IGC procedures, this sensor has no external pneumatic connection. To carry out the baro calibration procedure it is necessary to remove the instrument from the glider and place it in a vacuum chamber. The procedure is as follows:

- Switch the instrument **ON**, and wait some minutes (straight line on the barogram beginning)
- Set logtime to 1 second
- Place it in the chamber and carry out a short climb to about 1000m
- Bring the chamber pressure to exactly 1013.2 hPa
- Decrease the pressure by 1000m and hold for about 30 seconds
- Continue the procedure to 6000m
- Increase the pressure in 1000m steps back to 1013.2 hPa
- After reaching ground wait about 3 minutes and switch the instrument off
- Leave the instrument minimum 5 minutes off
- Read and print the barogram using the Lxe PC program

The barogram will be the last flight in the logbook.

2.3.3 Speed command

Speed command flying based on the McReady theory is a very useful tool to optimize cross country speed. There are many visual indicators (see LCD Vario). When the instrument changes to speed command mode, the audio will change and become a director informing the pilot whether he is flying too fast or too slow. In order to reduce confusion between vario and speed command audio, some special features were developed:

- Continuous audio signal in + possible (other kinds of signals can be chosen, see setup)
- No audio at correct speed (dead band).

2.3.4 Final glide calculation

The final glide calculator calculates the **final glide altitude difference** to the selected point (APT, TP). In the task mode the final glide is always calculated from the current position, round all uncompleted turn points to the goal. A + indication will inform the pilot that the glider is above the final glide slope and vice versa. The final glide takes into account **Mc setting, wind, bugs and safety altitude**.

Note!:

The elevation of the finish point is imported from the TP database into the final glide altitude difference. If this elevation is incorrect, or is set to zero, and the altimeter is set to QNH, then the final glide will be in error.

It is therefore important that the elevation of the goal is correctly entered in the TP database.

The safety altitude (reserve) input does not affect the glide difference indication which should be 0 m/ft during the final glide. It simply means that the glider will arrive over the goal at the selected safety altitude.

2.4 Flying with the LX 7007 PRO IGC

To get the best out of the LX7007 PRO IGC, it is important that some preparation is done prior to the flight - trying to configure the instrument or set up a task while flying the glider may spoil your whole day! Pre-flight preparation will ensure that the flight will be both successful and enjoyable.

2.4.1 Switching ON and selecting pilot

Pressing the **ON/START** button will switch on the LX 7007 PRO IGC. The instrument will go through the initialization phase and stop on the pilot selection. On selecting the pilots name and pressing enter it will continue the initialization until the **Set Elevation** menu (entering elevation of the take off airfield) is reached. If the instrument has not previously been programmed, the pilot name selected will be 'UNKNOWN' and it will go straight to the **Set Elevation** page.

Single pilot option

If only one person flies the glider, then only his name should be programmed into the instrument through **FLIGHT INFO**. The LX 7007 PRO IGC will then show the name of the pilot during the initialization procedure and switch automatically to the **Set Elevation** page.

Multipilot option

Up to 30 pilots can be stored in the pilot list of the LX 7007 pro IGC. The first pilot has to be entered into the **FLIGHT INFO** and then copied into the pilot list via **ADD PILOT TO LIST (Y)**. Further pilots can be registered under **SETUP / PILOTS** with **INSERT** through **Flight Info** at any time. Pilots, who want to have their individual settings saved, should use **EDIT** (under **SETUP / PILOTS**) function. In addition to the name, the settings can be protected by a personal password of up to four characters.

After the initialization routine, all pilots are selectable using the **UP/DOWN** selector and pressing **ENTER**. If the cursor remains on the **first letter** of the pilot name, it indicates that more than one pilot name is stored and selection becomes **obligatory**. The pilot name 'UNKNOWN' is always available and can be selected, in which case the **FLIGHT INFO** settings of the last flight will be used. After the pilot has been selected, his last individual settings **will be recalled**. If the pilot has protected his data with a password, he must enter it now

```

Glider:
  ASH 25
Pilot:
  M. SEISCHAB
  
```

```

Glider:
  ASH 25
Password:
  MI**
  
```

The **password** prevents another pilot from changing the configuration settings that have been set up by the named pilot. As soon as a pilot has been selected, the LX 7007 PRO IGC switches into the SET ELEVATION menu.

In Summary:

- If **UNKNOWN** pilot name is selected, then the FLIGHT INFO settings from the last flight, irrespective of the pilot, will be used
- If a **Pilot** without a password is selected, then the FLIGHT INFO settings of the last flight by that pilot will be used.
- If a **Pilot** with a password is selected, another pilot is not able to use his name nor alter any of his stored settings.

Note!:

If a single pilot flies the glider in different configurations, then it is recommended that he uses the multi pilot option listing his names as 'AN OTHER 15m' and 'AN OTHER 18m' for instance. This will ensure that the correct polar will be used as it is one of the stored individual settings.

2.4.2 SET Elevation (take off elevation input)

We all know that air pressure changes all the time and it is important that the altimeter is re-referenced before each flight. After completing the initialization, the instrument requires that the elevation of the present position is entered.

SET ELEVATION:
0185 ft

This setting is **obligatory**. The instrument will offer the last airport which was on the top of the NEAR AIRPORT list. If this is OK, the pilot can either simply confirm the offered elevation, or alter it. After setting the elevation, an input of the current QNH setting is called for. This is not mandatory, but very useful as by entering the QNH will enable the pilot to subsequently alter it as necessary during the final glide. If the QNH is not entered, it can be ignored by pressing **ESC**, but the pilot will then be unable to subsequently alter the QNH setting during the final glide.

QNH:-----mb

Setting QNH

- Rotate **UP/DOWN** and 1013 mb will be offered, or
- Use **ENTER** and **UP/DOWN** to enter actual value

Note!:

If the QNH is not set in the startup procedure, it cannot subsequently be changed in flight.

2.4.3 Preflight check

It is strongly recommended to check all settings in the setup mode access able without the password in case they have been changed by a previous pilot. All parameters remain unchanged after switching off, with the exception of:

- QNH
- BUGS
- Ballast if not defined with **set** in setup LOAD

It is recommended that a task is set up prior to take-off. It can either be imported from a PC, LX20 or Colibri set up at home or during briefing, or entered directly into the instrument.

Note!:

When attempting an FAI Badge Flight, do not forget to make an electronic declaration before take-off using the 'TASK DECLARE' procedure. **While declaration during or after the flight is possible, the declaration will not be valid for IGC or competition purposes!**

2.4.4 Performing the flight

It is recommended to switch the LX 7007 PRO IGC on some minutes before the estimated take off time to ensure that the GPS is locked on, and the obligatory baseline for the barogram in the IGC file is made

If a task (TSK) is to be flown, please ensure that:

- The correct task is selected. It should be checked (by using the EDIT) that the correct TPs are selected and are in the correct sequence.
- Point '0' is always the start point (not the take off point).
- Declare the task, if you want to achieve a FAI-badge, record, or decentralized flight.
- Do not forget to change the declaration if your task start point is not also the take off point!

2.4.4.1 Preparing a task

While it is advisable to prepare the task correctly before taking off and thus avoid mistakes made in haste, all the following actions, with the exception of a FAI Declaration, can also be done during flight.

1. Entering the task

- Transfer the task file from a PC, LX20 or Colibri
- Copy a similar one and edit it (saving of time)
- Enter a new task manually.

2. Check task

- Correct TP's and in the correct sequence.
- That the Task distance is correct.

3. Sector editing

If planning to fly an AAT, the local sectors should be set in the ZONE menu under TASK / EDIT.

Example:

A sector is defined as an area between the radials 30° and 70° related to the turn point, the radius is 20km.

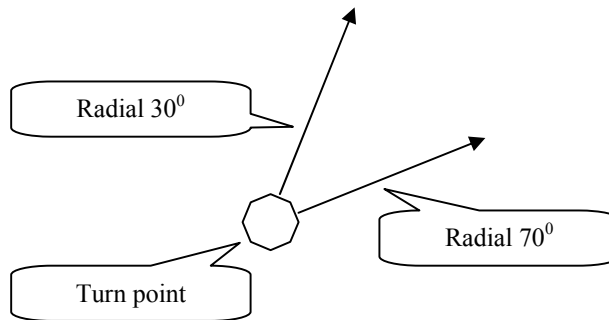

101WEIDE	1.Point
A21: USER VAL	230°
A1:	20°
R1:	20.0km
A2:	0°
R2:	0.0km
AUTO NEXT: Y	

For that sector enter:

- A21 USER VALUE 230° (50° + 180°); 50° is the symmetric axis between the two radials (30° + 20° = 50°, because the complete sector has 40°)
- A1 20°, because the sector angle is 40°
- R1 is 20km
- A2 and R2 are 0

2.4.4.2 Starting a task

If the glider is flying into the start sector and the pilot decides to start the task, the following steps must be followed to start the task:

- Wait until the message **INSIDE** appears, indicating that the glider is in the start sector
- Press the **START** button (short press)

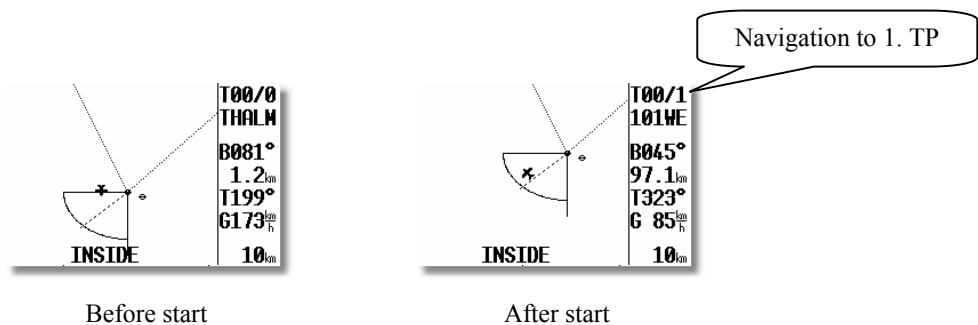

A task cannot be started on the ground. Pressing the **START** button (about 1 sec press), starts the task. A indication that the task has started is that the navigation data changes to the first TP.

It is also possible to start a task, while the glider is outside the start sector. In this case the pilot has to press **START** for a longer time (about 6 sec., but in any case long enough until the TSK navigation data to the first TP appears). Once the task has been started, it can be terminated at any time during flight and a new start made. If a task has already been started, press **ENTER** and the following screen will appear:

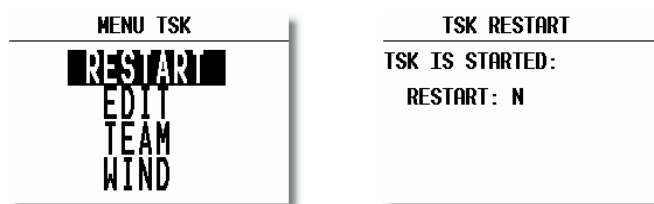

Confirming **RESTART** with **Y** will restore the actual task. The task is now ready for new start. **The restart has no influence on recorded data or declaration.**

2.4.4.3 Automatic swap on reaching a TP using standard task and AAT

By default, the LX 7007 PRO IGC switches over to the **navigation data of the next turn point**, as soon as a fix is recorded in the sector of the destination TP. If a turn point cannot be reached, the pilot can manually switch (jump over) to the next turn point by pressing **START** for approx. 6 sec. (just watch nav. data). Alternatively, he can delete the unreachable turn point in the **TASK / EDIT**(recommended). **Neither action has any effect on the declaration!**

Note!:

When flying an AAT and using the **ZONE** function, there are three ways that the **AUTO NEXT** parameter may be set to **N**:

- Setting **N manually**,
- Selecting **R1 to more than 10 km** (N will be set automatically),
- Use of the **MOVE** function before reaching the sector.

In each of these cases the **AUTO NEXT** parameter is automatically set to 'N', and **when inside the AAT sector**, it will be necessary to manually change to the next TP by making a short press of the **START** button. When this is done, the present position becomes the new TP in the AAT, but the screen will continue to show the old task structure. However, if the TP has already been **MOVED** prior to entering the sector, then pressing the **START** button will make the present position become the new TP, and the task will be modified with new # TP. This ensures that the statistics remain correct, both during and after flight. It is therefore **recommended** that the **MOVE** function is used prior to entering the AAT sector

2.4.4.4 Use of MOVE function

When an AAT is tasked, the pilot has to decide how far into the sector he wants to fly. The **MOVE** function (see Para 3.2.5.2) modifies the task automatically as the TP is moved, recalculating the distance, ETA, required average speed, final glide and minimum glide ratio to reach the finish line, taking into account any safety altitude that has been set. Once the task has been started, the **MOVE** function is immediately available for the next TP on pressing **ENTER**, irrespective of which navigation page is selected.

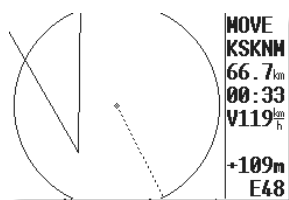

Note!:

After using the **MOVE** function, once the glider is in the AAT sector, the pilot is able to change over to next TP simply by pressing **START** at any time. The current position will then become the #TP just turned, the task will be modified automatically and it will be written into the statistics.

Example:

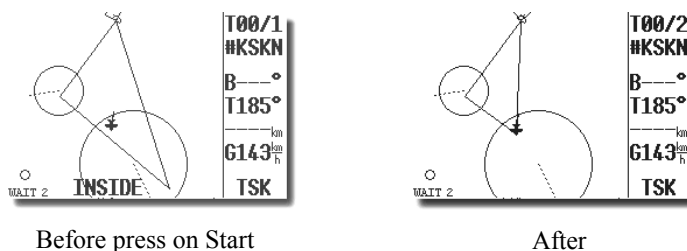

2.4.4.5 TSK END

On entering the finish zone the task stops automatically and a message TSK END will appear. If you want to fly a new task without landing, then it is necessary to use RESTART and SELECT. If the MOVE function has been used on the finish point, then it will be necessary to finish the task by using the START button as in the AAT sector.

Note!:

If the finish regulations prescribe entering a cylinder, usually 2 km radius with a base of 200m, then program the finish zone to the cylinder parameters and set the safety altitude in INIT to the height of the base of the cylinder. When on the final glide, MOVE the finish point to the border of the cylinder and all it is then necessary to do is to fly the glider to keep the final glide deviation on 0m.

2.4.4.6 Procedure after landing

IGC Regulations require a straight line (base line) in the barogram at the beginning and end of the flight. For this reason that it is recommended **not to switch off the unit OFF** immediately after landing, but to wait a few minutes. About 3 minutes after landing, the following message will appear on the screen:



Let the message time out a new message will appear saying that the SECURITY algorithm is being calculated. Pressing **ENTER** before the screen times out will allow the flight to continue until the unit is powered down.

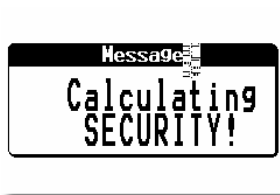

This message will remain for about one minute and during this time the instrument is writing the security information that validates the .IGC file. When it is finished, it is safe to switch off the instrument. Confirmation that the procedure is complete can be checked by selecting the **Statistics** page: if the **logbook** is shown, then the procedure is finished. **Never switch off the unit while it is CALCULATING SECURITY.** If the unit is accidentally switched off immediately after landing, it will not cause any problem. When switched ON again, the calculating security message will appear for a minute or so.

2.4.4.7 SIMPLE TASK

The simple task feature is active prior to a **regular task being started**. The feature is very useful for pilots who do not fly tasks but fly from TP to TP (or to an APT). Simple task permits statistics to be stored like a real task and which can be displayed on the Statistics page and also evaluated by a PC after flight.

Immediately after take off, the current position will be considered to be a **start point**. On reaching a TP or APT which has been selected in TP or APT pages, the point will be treated as a TP in a simple task and so on. The radius to define confirmation of arrival at the TP is set by pilot in „NEAR TP“ (SETUP/PASW/TP). The simple task grows as more and more TPs and APTs are reached. The flight statistics are the same as a real task except that TSK S shows that no regular task is being flown.

STATISTICS	
TSK S/1:	THALMAES
Time:	0:52:19
Duration:	0:08:11
Speed:	126 ^{km} _h
Vario:	---% 0%
Engine:	-'-''

A new simple task can be started by carrying out a **RESTART** procedure, and the actual position at the time of the restart will be the start point in a new simple task.

3 PC, PDA and Colibri/LX20 Communication

Note!

The unit is able to adapt automatically to the baudrate of the partner unit, so no any more problems, if both units don't have the same baudrate. A very typical message **AUTODETECT** will inform about searching for synchronisation. After synchronisation is established a **CONNECT** status will appear.

The LX 7007 PRO IGC is able to communicate with a:

- PC, using LXe, SeeYou, Strepla or CAL programs.
- PDA, ConnectLX, Downloader
- LX 20
- Colibri
- Posigraph

Note!

The unit is equipped with three **physically separated** com ports, which means no data collision even all possible devices connected and switched on.

The following data can be transferred bi-directional between a LX20, Colibri or Posigraph

- TP and TSK data (DA4)
- Flight information

Using the LX7007 PRO IGC in conjunction with a LX20 or Colibri, it is possible to prepare a flight at home or during the competition briefing, and then when at the airfield use the LX20 or Colibri as a data source for LX 7007 PRO IGC. Similarly, a task can be programmed in a PC and then transferred to a LX20 or Colibri for subsequent loading into the LX7000 PRO IGC.

Using of a PDA will do the same, but additionally offers downloading of flights, which means practically no use of PC in cockpit any more. Flying a competition PDA can be used like data transportation medium Glider – Scoring office, while the flights stored in PDA includes **secure data**.

3.1 Communication with PC

After PC communication art was chosen by the pilot, a PC connected to the **5P round** connector normally positioned on the instrument panel, can be used. All kinds of PC communication can be provided using of **IGC port** available on the rear side of he unit. Use standard IGC cables.

Note!:

The LX 7007 pro IGC uses **.CUB** format of airspace data structure. Ensure that the version of LXe used to load airspace is build 25 April 2005 or later; never use old versions of LXe to load airspace.

Communication with a PC is via the RS232 serial COM port. If your computer only has an USB port and noreal serial COM port, then you will need to obtain an USB to serial adaptor, available in every computer shop. To couple the unit to the COM port, a special cable is supplied with the LX 7007 PRO IGC which terminates in a SUB D 9 pin socket, on the PC side.

A CD with the following programs is supplied with LX 7007 PRO IGC:

- LXe Windows program for communication, basic flight evaluation and database management.
- SeeYou (1.9) - for task preparation and detailed flight analysis.
- LxasBrowser for airspace management and its manual.
- ConnectLX for communication with PDA, no navigation functionality required

Using the LXe program, the following procedures can be carried out:

- Read logger
- Read *.da4 (TP and TSK files)
- Read flight info
- Write *.da4 (TP and TSK files)
- Write flight info *.hdr
- Write APT
- Write airspace (**.CUB** files only)

LXe **will automatically recognize** an instrument requesting **.CUB** file and will offer browse function to find adequate **.CUB** airspace file.

Another very useful function of LXe is the preparation of task details such as start, TP and finish sectors. Using the menu ZONES in Lxe, the details of AAT sectors can also be programmed. All this data can then be transferred to the LX7000 PRO IGC.

LXe can also be used to update the APT and airspace database. Such updates are free and and **no update code** is necessary any more.

Note!

LX 7007 has a memory capacity for maximal 6 **.CUB** airspace files. To replace one with another simple load a new one. Replaced will be overtime time the active airspace file. Flying a competition where some special versions of airspace is issued, overwrite the airspace which you normally don't use, to prevent missing of airspace data after returning home.

The CONNECT status is achieved as follows:

- **On the PC run program LXe**
- **On the LX 7007 PRO IGC go to SETUP – TRANSFER / PC**
- **On the LX 7007 PRO IGC press ENTER and wait some seconds until AUTOCONNECT finish and CONNECT appears**

CONNECT indicates that both LX 7007 PRO IGC and PC have established connection and are ready for data exchange.

Note!

IGC Shell program (developed by IGC) in conjunction with LXC-IGC.DLL can be used for flight download, convert to IGC and validate. Both programs are available on www.fai.org/gliding/gnss/freeware.asp. This kind of communication is mostly used by competitions, for private use we recommend LXe.

3.1.1 Some help having problems with communication

3.1.1.1 General

90% or more problems causes from PC side. Practically no problems on LX hardware found till now.

Having mentioned problems, please go carefully through that document and having too low knowledge about PC operating system, please contact some experts.

Some units are delivering NMEA data sentences. This data could be recognized by PC like external mouse, if the unit (Colibri.....) will be connected before LXe is running.

Solution: run LXe at first and plug in serial cable coming from the unit after.

3.1.1.2 Troubleshooting with LXE

- Available communication ports for LXE (Setup→Comm. Port)

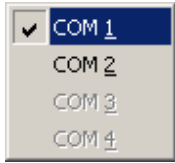

Highlighted ports are ready to be selected.
 Means that LXE will use checked port for communication with LX, there is no automatically selection by LXE. Selection of comm. port should be done after first run of LXE.

- No ports available



After such message, no communication will be possible.

Reasons:

- **PC has no serial ports** (LAPTOP with USB only – the only solution is USB to RS232 adapter – available in computer shops – necessary to install drivers
USB-232 adapter should be plugged in **before starting LXe**)
- Ports are occupied by another applications – programs (E.g. Active sync program for communication with PDA's)

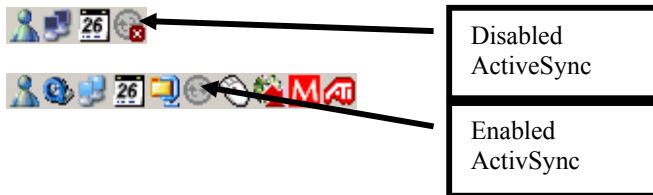

How to disable Active Sync ?

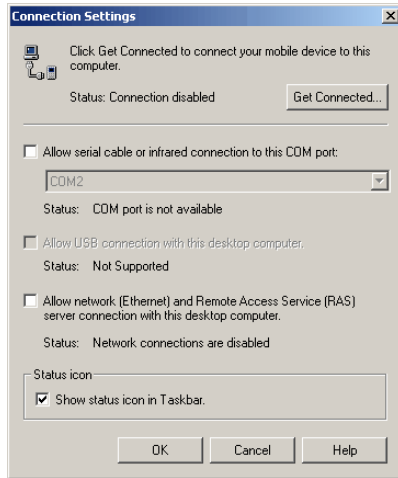

After right mouse click on ActiveSync symbol in task bar, choose *Connection settings...* and disable it. (PC's with only one comm. port).

Problems caused by USB to 232 adapters.

Normally PC has more than one USB port. On first use of USB/232 adapter, operating system will detect new USB device. Wizard will guide you through setup process of drivers for specified USB/232 adapter. After successfully installation of USB driver Lxe will detect new additional comm. port. Usually the number of new comport is higher than 4. (COM5, COM6...)

It's recommended to use always the same USB port on PC (physically). If you use another USB port, new installation of USB/232 driver will be necessary. Operating system will add next free communication port.

3.1.1.3 Recommended LXE settings for safe communication

- Fixed baud rate
- 19200 bps
- Keep connected during preparation....

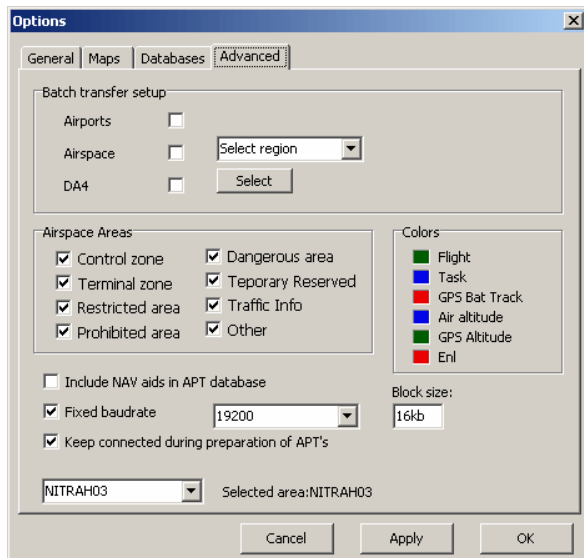

3.1.2 Having problems downloading flights (read selected flight-command).

Symptoms:

- Baud rate speed is not constant (oscillating from 0k to 19k)
- More retries downloading blocks

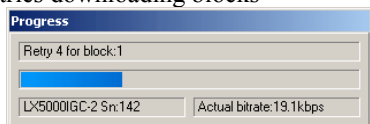

Result could be unsuccessful downloading of the flight.

Workaround:

- Reduce communication speed to 9600 bps or lower and do the same on LX unit. (that is a typical problem by laptops using USB adapter)
- Reduce block size (Options/ Advanced)

3.1.3 Additional help from LX navigation

Haven't found any solution, please use *Help*→*Troubleshooting* form of Lxe and send it to support@lxnavigation.si

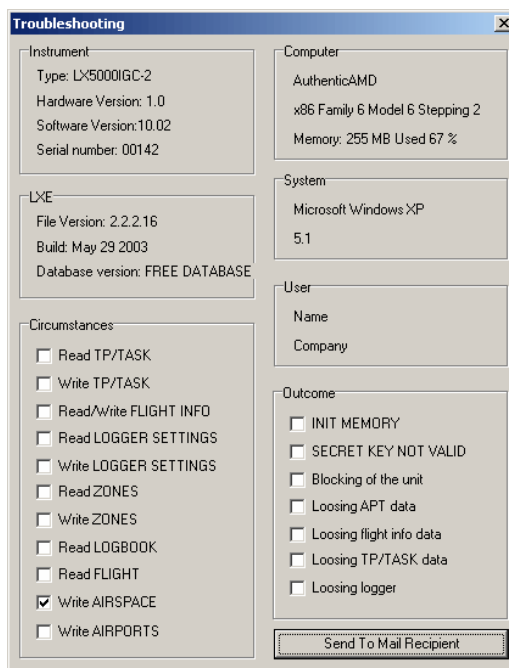

3.2 Communication with PDA

A completely separated com. port with his own 9P sub D connector is situated on the rear side of the unit. LX 7007 has a built in DC/DC converter which ensures 5V power for PDA. A standard LX cable (1638 or 1636) will connect practically all iPAQ devices to LX 7007 without any additionally works. Main functionality of the port:

- Sending of NMEA data to PDA, see capture SETUP/NMEA
- Exchanging of data LX 7007 – PDA including **flight downloading**

Use free PDA program **ConnectLX** or Downloader from FlywithCE.

Note!

Cable to connect LX 7007 and mostly all types of iPAQ is delivery included,
Cable LX 1638 will connect:
 H22xx, H38xx, H39xx, H41xx, H43xx, H51xx, H54xx in H55xx, H4700
Cable 1636 will connect:
 36xx, 37xx,31xx

If not specified cable 1638 will be delivered. After special request cables with open wires can be delivered to allow connection of third party PDAs.

3.2.1 Connect procedure to PDA

Run **ConnectLX** and select Device type like COLIBRI.....LX7000, define com port and other necessary parameters, com speed doesn't matter.



Select **TRANSFER/PDA** on LX 7007 and press Enter. After AUTODECT procedure a very typical message **CONNECT** will appear on the LX 7007 screen. Define art of transfer using **Actions** menu on PDA and proceed with next. For details see ConnectMe manual on www.seeyou.ws.

Note!

Having problems with connect, make sure those other applications like SeeYou Mobile..... are regularly closed, otherwise they occupies the com port. Close the applications using EXIT.

3.3 Communication between LX 7007, Colibri or LX 20

The LX 7007 PRO IGC is able to exchange data (bi-directional) with the LX 20, Colibri and Posigraph. The following data can be transferred:

- *.DA4 files (TP and TSK)
- Flight info
- confirmation procedures (ZONES)

Note!
LX 7007 powers Colibri or LX 20-2000 units connected to the LX 7007 IGC port. For older LX 20 versions order appropriate cable.

3.3.1 Data transfer LX 7007-LX 20

To establish data transfer with the LX20 use the following steps:

STEP	LX 20	LX 7007 PRO IGC
1	Main MENU / LOGGER	SETUP / TRANSFER/COLIBRI/LX20
2		ENTER
3	READ or WRITE key	Select transfer function
4		ENTER

The LX 7007 PRO IGC acts as a **master** device and forces the LX 20 to respond to the commands.

Transfer menu on LX 7007 PRO IGC

READ TP/TSK
READ INFO
READ ZONES
WRITE TP/TSK
WRITE INFO
WRITE SETUP
WRITE ZONES

Read means LX 7007 PRO IGC will read data from LX 20 or Colibri and vice versa

Read zones means copy of confirmation zones architecture from Colibri or LX 20 and write means vice versa.

Write setup will write logger setup (recording intervals etc) from LX 7007 pro IGC into LX20 or Colibri

Note!
To connect LX 20-2000 use cable delivered with LX 7007, the cable should be plugged into IGC marked telephone type connector. Using of 6 pole cable doesn't matter. Having an older unit order an adequate cable

3.3.2 Data transfer LX 7007-Colibri

Communication with a Colibri or Posigraph recorder is much simpler. The Colibri or Posigraph will **CONNECT** automatically after selecting **TRANSFER/COLIBRI/LX 20** then **ENTER** on the LX 7007 PRO IGC. The **CONNECT** status is signaled by a series of audio beeps from the Colibri or Posigraph. LX 7007 will act as a master. The same features like by communication with LX 20 are available.

Note!
To connect Colibri use cable delivered with LX 7007, the cable should be plugged into IGC marked telephone type connector. Using of 6 pole cable doesn't matter. Using of this configuration will power Colibri from LX 7007.

4 Installation

The LX 7007 PRO IGC main unit (LX 7000 DU) needs one standard 80mm cut-out. The Vario sensor unit (LX 7007 AU) and any additional vario indicators need a standard 57mm cut-out each.

Three pressure connectors are fitted to the back of the LX 7007 AU. **A label shows their functions.**

- Ptot = Pitot or Total pressure
- TE = TE probe
- Pst = Static

If the unit is to be configured for electronic TE compensation, then the connections are as follows:

- TE/Pst Static
- Pst Static
- Ptot Pitot or Total pressure

If the unit is to be configured for pneumatic TE compensation using a TE tube, then the connections are:

- TE/Pst TE tube
- Pst Static
- Ptot Pitot or Total pressure

Note!

If the Ptot and Static are connected the wrong way around, there will be no integrator reading (average climb) during the flight. The LX 7007 DU is connected to 12 volt power via the 15 SUB D connector. Both units are connected via the 485 bus and the connectors are marked like **1-1**. It is not possible to connect the DU and AU incorrectly as some pins are **removed** and some sockets **blanked** off.

Note!

There is **no fuse in the instrument** so it is **VERY IMPORTANT** to use an external fuse (max. 3A). Power supply cables should use a minimum of 0.5mm² wires (20 awg). To prevent **damages on LX 7000 80mm** unit after a short on 485 bus, a fuse of blade type (the same fuses are used in modern cars and therefore available on petrol stations) is built on the rear side of the unit. After a short happened 57 mm unit will not work any more, but the reason is not the defect of 57mm unit, but the bowled fuse. Use 3 A fast acting blade type fuse (violet).

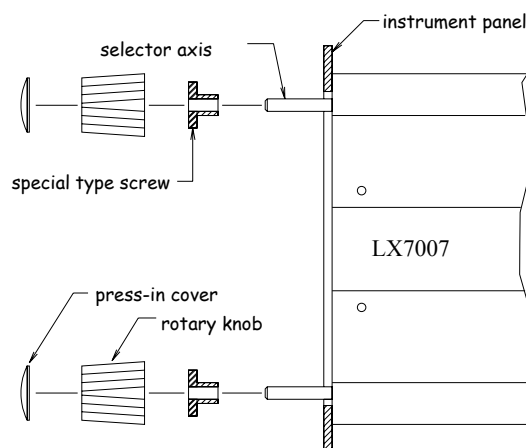

Installation of the LX 7007 PRO IGC

- Prepare the cutout in the instrument panel according to the drilling template.
- Remove the press-in covers from the four main selectors on the LX 7007 PRO IGC. You can now see the mounting screws.
- While holding the knobs, slacken the screws with a screwdriver. Now the knobs can be removed (never use power to remove the knobs, you can **damage rotary** switches). By problems **hit on the slacken screw** a little bit.
- Remove the four special type screws.
- Position the LX 7007 PRO IGC in the cutout in the instrument panel.
- Tighten the LX 7007 PRO IGC with the special screws (8 mm tool).
- Tighten the knobs and replace the covers
- LX 7007 AU doesn't need any changes having standard 57 mm cutout.

Mounting Template:

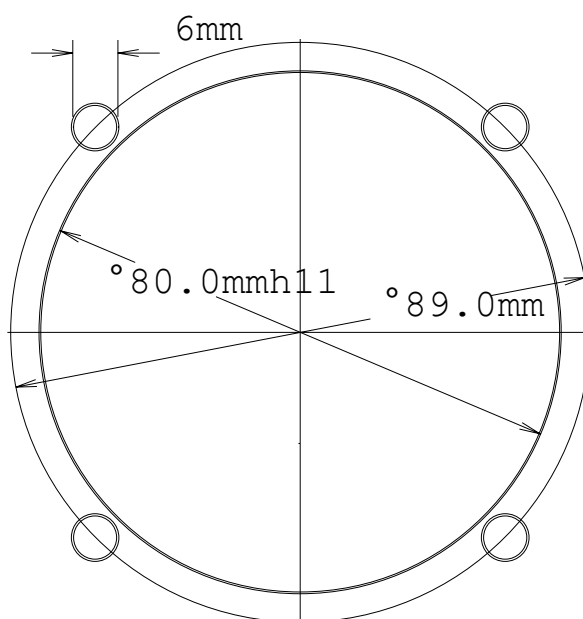

4.1 Installation of PDA units

LX navigation offers a wide range of accessories which makes installation of a PDA in conjunction with LX 7007 extremely easy and completely plug and play. LX 7007 has a separate com port specially designed to drive PDA, 5V power for PDA is included. Using of LX standard cables is possible to connect practically all iPAQ units to LX 7007. A cable is delivery included. There are two types of cables.

Cable 1636 for:

31xx, 36xx, 37xx

Cable 1638 for:

H22xx, H38xx, H39xx, H41xx, H43xx, H51xx, H54xx in H55xx, H4700

There are two swivel supports available.

iPAQ Handle for:

36xx, 37xx, 31xx, H38xx, H39xx, H51xx, H54xx, H55xx, H4700

iPAQ handle 22 for:

H22xx, H41xx, H43xx

4.2 LX 7007 pro IGC full configuration (all connections plug and play)

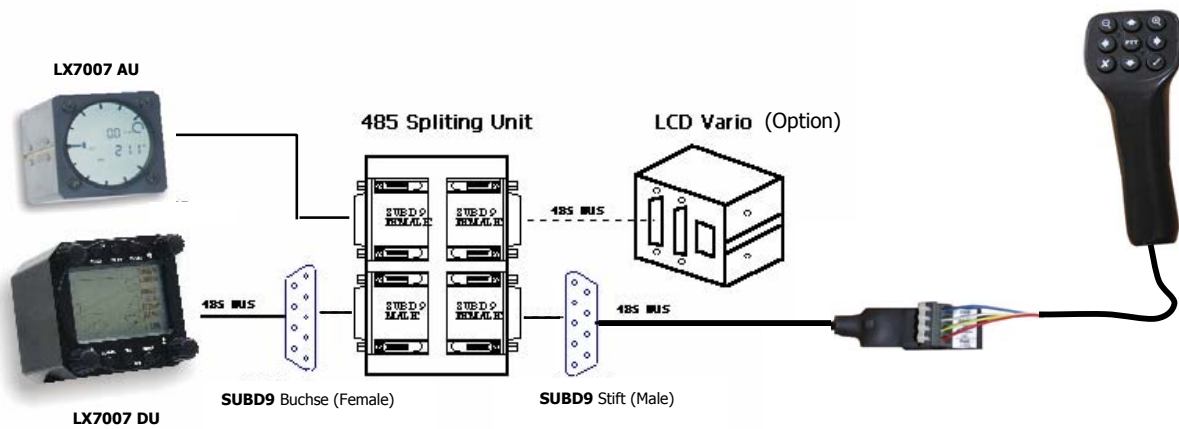
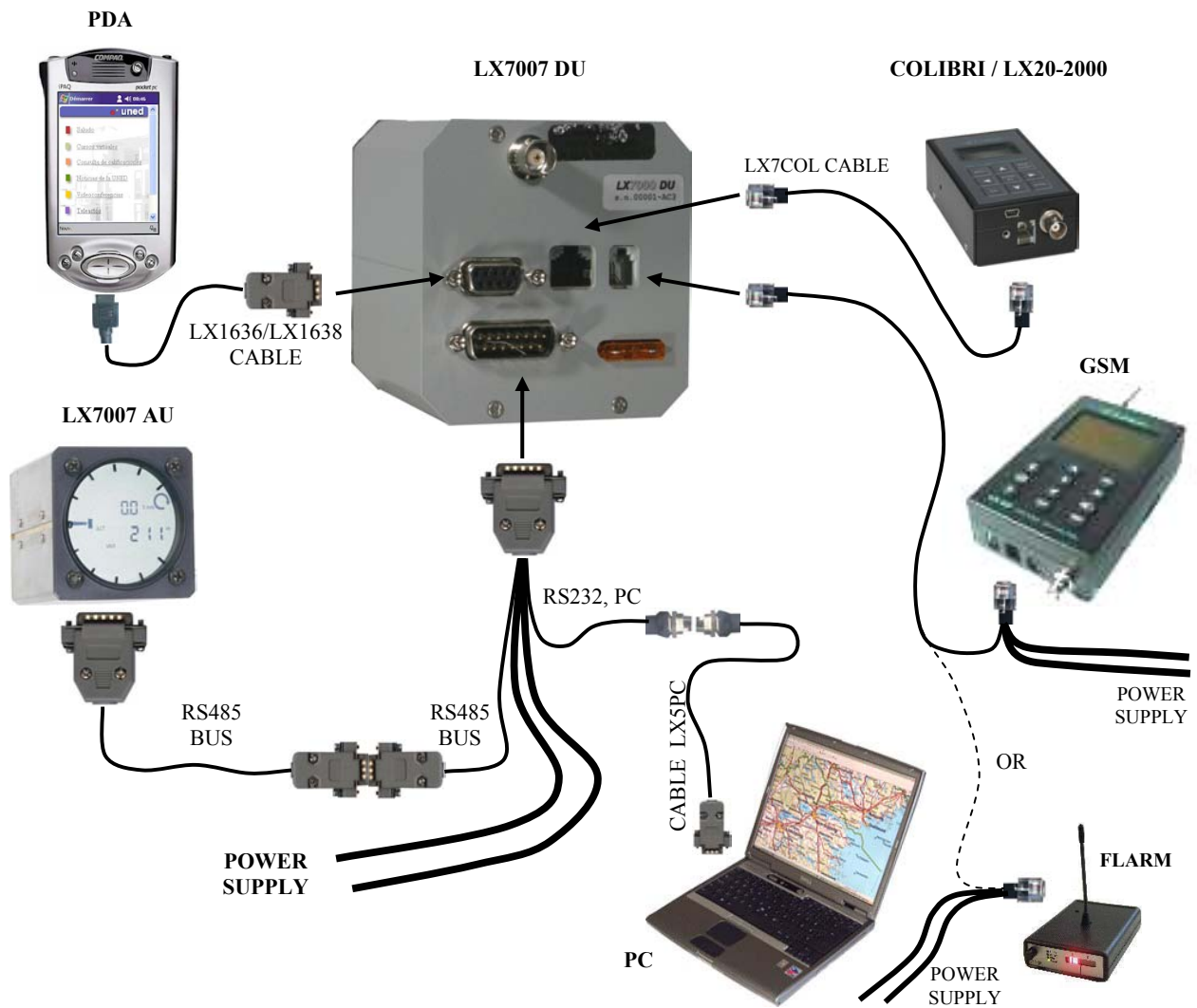

4.3 Wiring

LX 7007 ANALOG UNIT Wiring

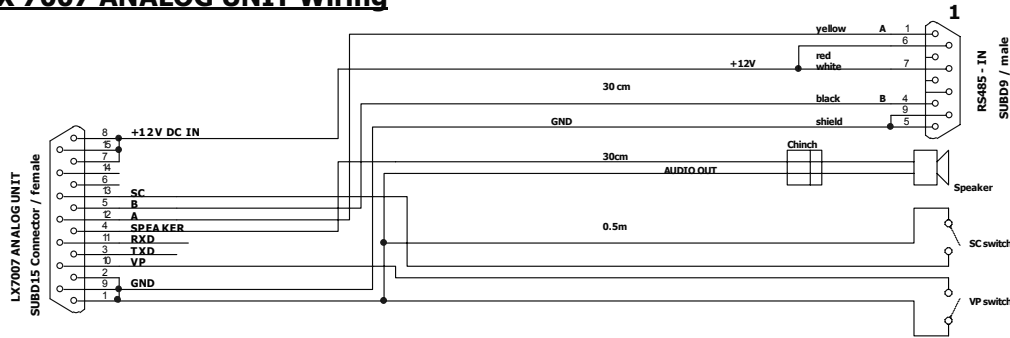

LX 7007 DIGITAL UNIT Wiring

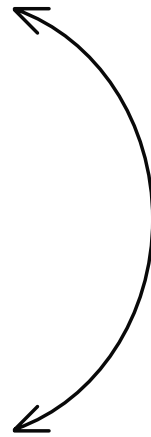
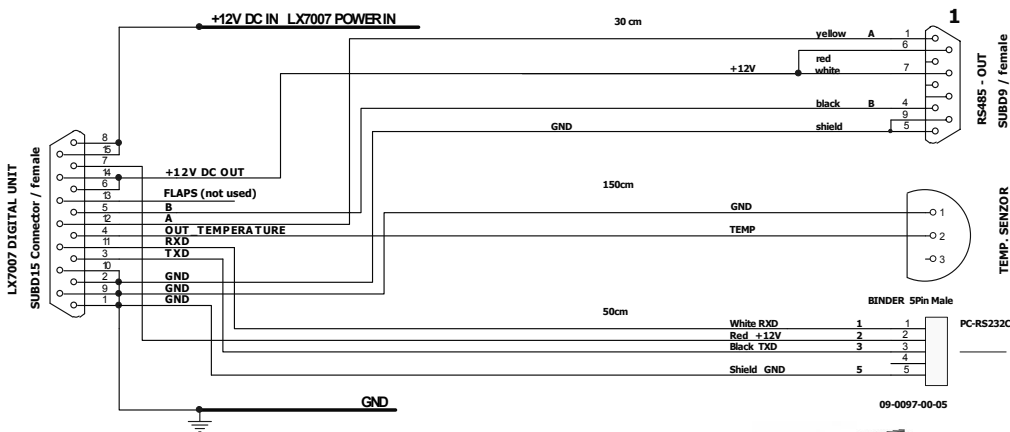

CONNECTED

LX7COL CABLE

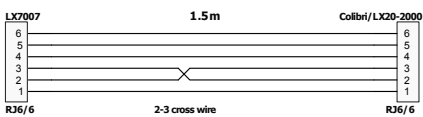

COLIBRI

OR



LX20-2000

LX5PC CABLE

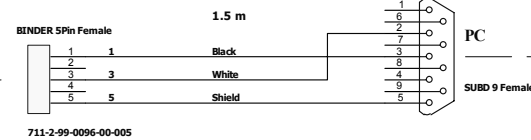

PC

CABLE LX1636 / LX1638

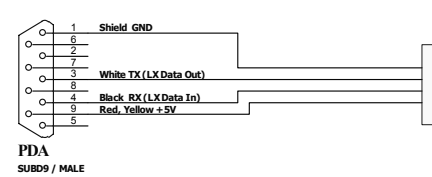

PDA

LX 7007 ANALOG UNIT Wiring

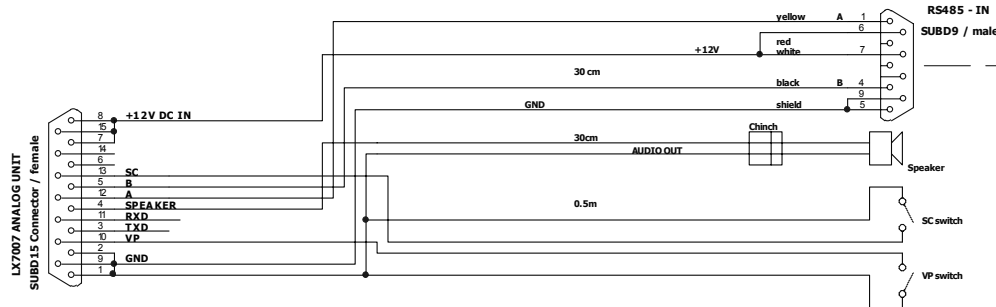

LX 7007 DIGITAL UNIT Wiring

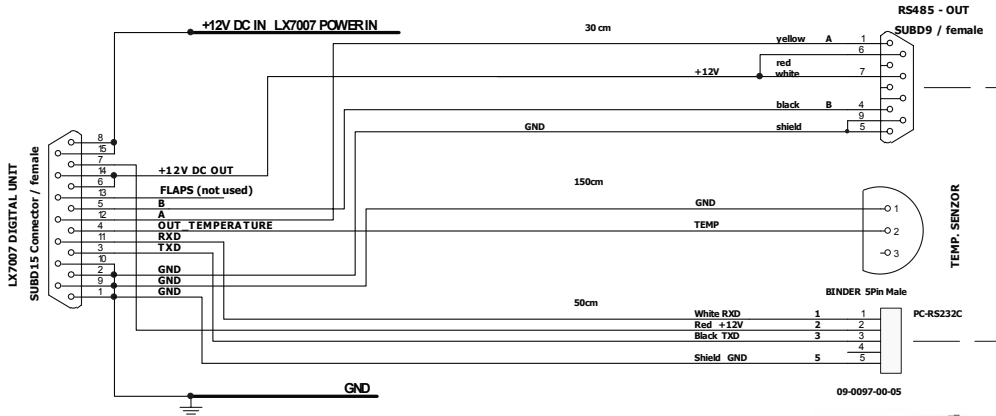

LX7COL CABLE

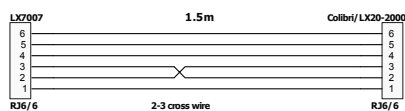

COLIBRI OR LX20-2000

LX7000 / LX20 Communication Cable (delivery not included)

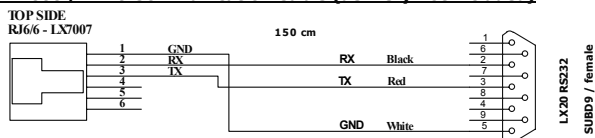

485 Splitting Unit (using additional LCD vario and Kompass)

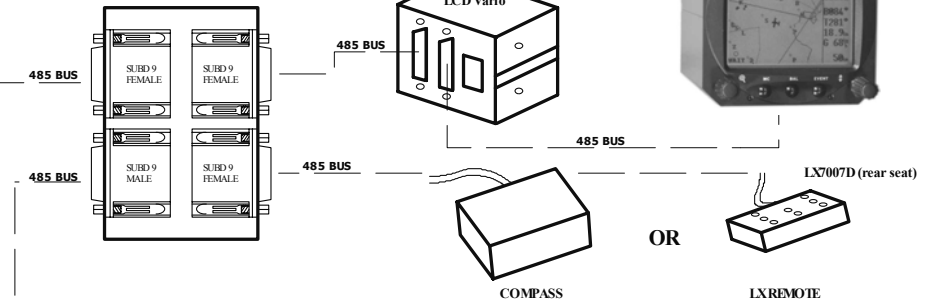

LX5PC CABLE

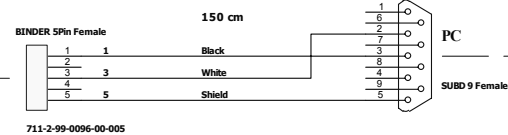

PC

CABLE LX1636 / LX1638

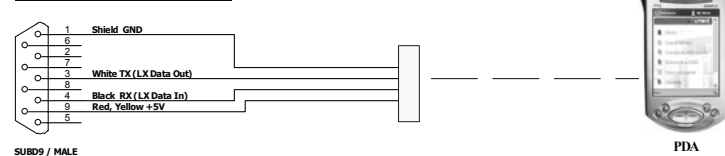

PDA

4.4 Tree structure Diagram

←MODE→

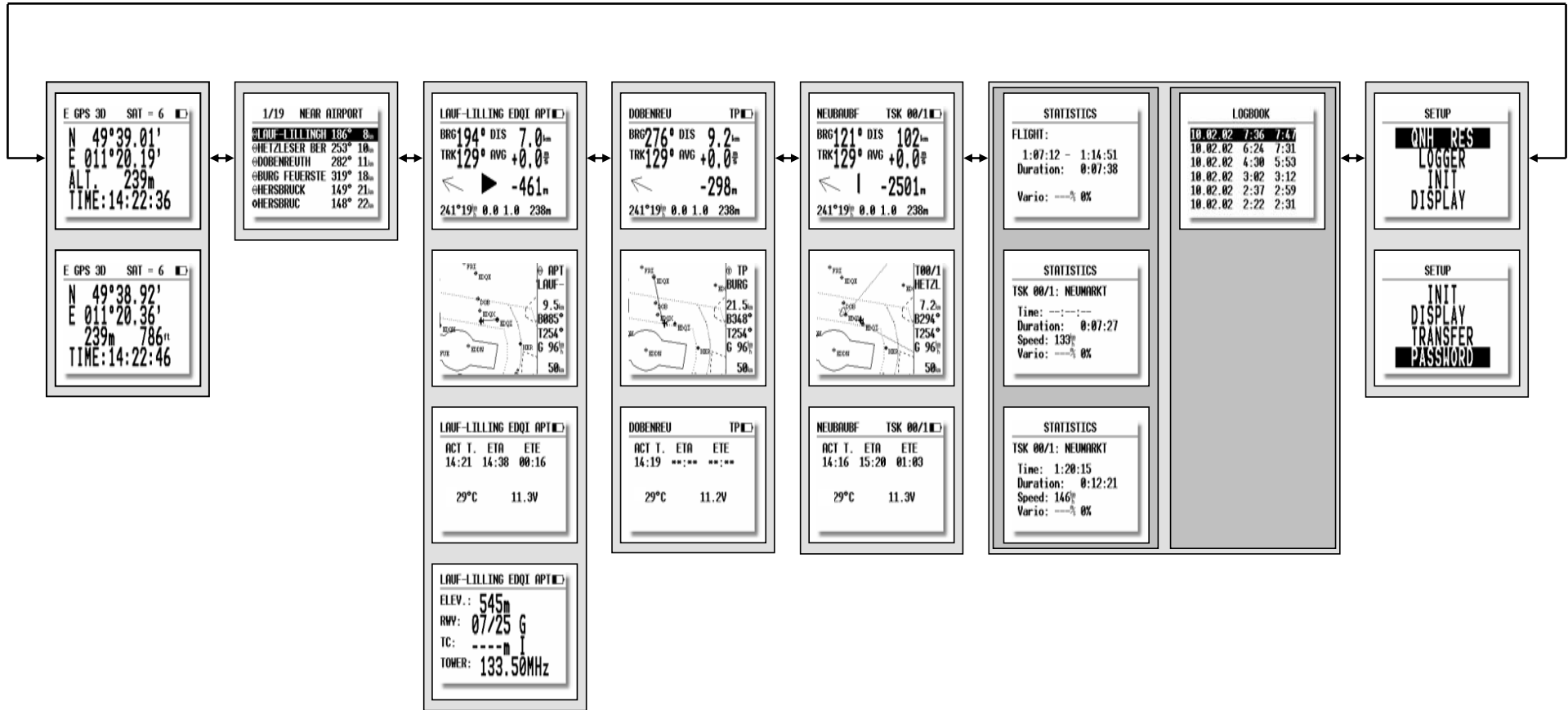

5 Passwords

- 96990 Set up System parameters
- 55556 Activate external NMEA input (internal GPS will be disconnected)
This function is active until the unit is switched OFF or a new input of 5556 is made
After using password 55556, the INTEGRITY of flight recorder data will be lost (active flight only)
- 99999 Delete all flights stored in the logger
- 01049 Auto-zero procedure (Vario and Altitude)

6 Options

6.1 LX 7007 PRO IGC - Compass Module

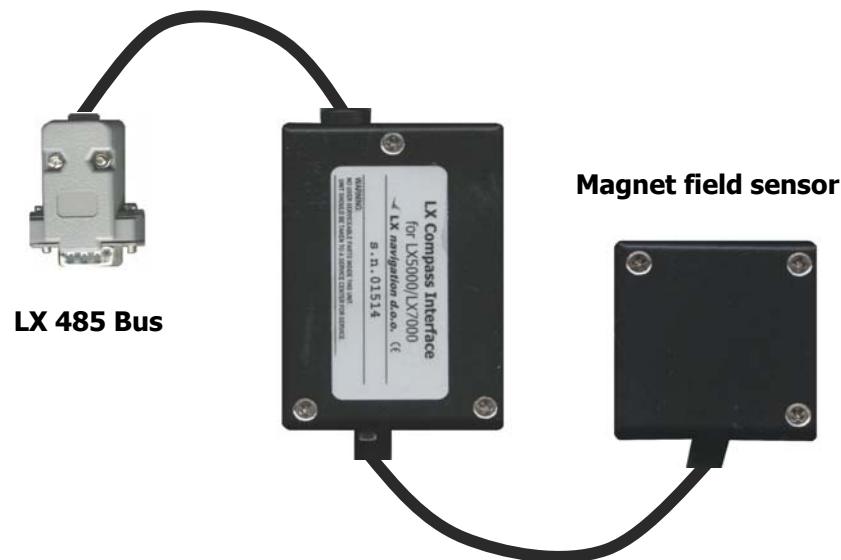

6.1.1 General

The compass module is an electronic compass (magnetic field sensor), which was developed for the LX 7007 PRO IGC. The LX 7007 PRO IGC recognizes the compass module automatically when it is coupled onto the 485 bus. The only configuration settings needed relate to the compensation procedure. An indication that the compass module is connected is the appearance of magnetic HDG reading on navigation page 3 of the LX 7007 PRO IGC.

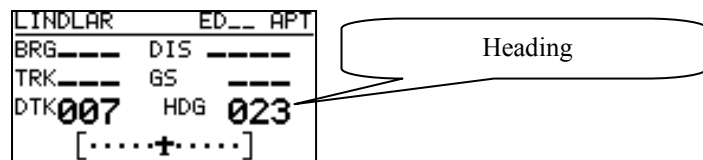

The compass module not only permits the display of magnetic heading but also permits the calculation of the **wind vector in straight flight**. The wind vector is calculated using the triangle of velocities method, where the vectors of ground speed with track, TAS with compass heading, and the wind vector form a triangle of velocities.

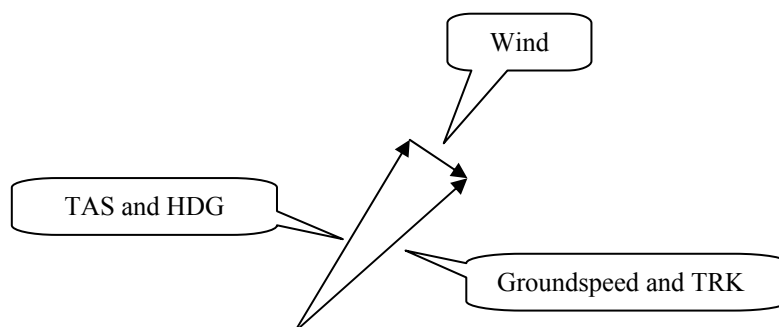

The angular difference between HDG and TRK depends on the magnitude of the wind vector and is normally quite small, which means that the measurement has to be quite precise if accuracy is to be achieved. While the GPS data (TRK and GS) is precise, small inaccuracies in the heading of about 5° can cause errors of up to 25km/h in the wind strength. This method only works during straight flight and the calculation is stopped as soon as HDG and TAS change rapidly as occurs when the glider is turning.

6.1.2 Installation of the compass module

The device consists of two parts, a compass sensor and electronic device. The compass sensor should be built somewhere far from iron parts, which can cause errors in reading. Respect flight direction arrow and install the unit horizontal. All connections are plug_and_play, so there is no mistake possible. A **485 splitting** unit to extend LX 485 bus is included. The box with electronic could be installed on the convenient place in the glider, orientation doesn't matter.

6.1.2.1 Where to install:

The compass module should be installed as far as possible away from magnetic, electrical and steel parts (loud speakers and analogue vario indicators contain strong magnets). Even the mechanical compass should be as far away from the sensor as possible. Minimum distance is 20cm. As mentioned above, the arrows should be aligned accurately in the flight direction and parallel to the fore and aft axis of the glider. For a proper installation a plane area parallel to the horizontal plane is needed.

6.1.2.2 First test after installation:

An external reference compass is required which can either be a prismatic landing compass or a calibrated compass base on the airfield surface. Using the reference compass, the glider should be aligned in each of the eight main directions (360°, 45°, 90°, 135°, 180°, 225°, 270° and 315°). Now the glider should be oriented into north direction, while doing that watch the HDG displayed on Nav.-page 3 of the LX 7007 PRO IGC (do not try to compensate the compass yet!). If the HDG varies more than $\pm 5^0$, turn the compass so, that the deviation decreases below $\pm 5^0$. Now turn the aircraft into the other directions and read the displayed values (don't change the compass position anymore). If they vary more than $\pm 10^0$ look for another place for the compass module.

6.1.3 Adjusting the compass module:

The compensation of the compass is made in the SETUP menu after entering the password (96990).



pressing ENTER

SETUP COMPASS			
COMPASS:			
N	000	NE	045
E	090	SE	135
S	180	SW	225
W	270	NW	315

1. Orientate the glider again to 360°.
2. Set the cursor on N and press ENTER (actual HDG is displayed).
3. Press ENTER again (storing the measured value)
4. Set the cursor on 45°, orientate the aircraft to 45° and again store the measured value.
5. Repeat the procedure for the remaining directions

SETUP COMPASS			
COMPASS:			
N	055	NE	045
E	090	SE	135
S	180	SW	225
W	270	NW	315

The compensation table will look similar to that above when you have finished the procedure. Leave the menu with ESC.

6.1.4 Final test:

Switch the LX 7007 PRO IGC back to Nav.-Page 3 and check again all 8 directions. The error should now be less than $1^0 - 2^0$ (better to have 1^0 !). If the errors are larger, then one should search for faults in installation or in the adjustment procedure. When the final test is satisfactory, your LX 7007 PRO IGC is ready to calculate the wind with the compass method.

Please Note!:

The calibration is specific for your combination of aircraft and compass, which means you cannot transfer the compass to another aircraft while using the same calibration values.

The parameters are stored in an EEPROM, so they will not get deleted when a memory initialization is performed or the internal Li-battery is exchanged.

It is recommended to repeat the calibration procedure every year.

6.1.5 Wind calculation during flight

For the wind calculation a finite time is needed to make the calculation. **This time (in seconds)** is entered in the **INIT menu under WIND/COMPASS**. The longer the time the more accurate is the computed wind, and vice versa.

If the pilot intends to use the wind calculation with the compass module, he has to select in one of the three Nav Pages the wind menu (just press ENTER when you are on one of the Nav Pages, move the cursor onto WIND and press ENTER again). Then choose the item **COMPASS**.

Please Note!:

- The wind calculation with the compass works exclusively in straight flight.

- The calculation is started when the following conditions are fulfilled for at least 5 sec.:

Speed should be constant – It should vary not more than $\pm 10\text{km/h}$ (6kts)

Flight direction should be constant, variation should be less than $\pm 5^\circ$

The measurement takes that amount of time (in sec.), that was defined in the INIT menu

The result is a new vector wind

If the limits given above are exceeded during the measurement, the procedure will be stopped and restarted as soon as the conditions are fulfilled again.

The higher the speed, the greater the potential error in the calculated wind.

What the pilot should do during wind calculation:

- **Keep the speed and flight direction as constant as possible**
- **Watch the wind display on one of main Nav pages (lower left corner)**
- **If WAIT is displayed, it means that the conditions for the measurement are waiting to be stabilized**
- **When the measurement is started, a time counter will start counting down (like 15, 14, 13, ...). This is the time in seconds until the calculation is finished**
- **When the procedure is completed without problems, a new wind vector will be displayed.**

6.2 LX 7007 PRO IGC – Remote control units

6.2.1 Remote control keyboard type

6.2.1.1 General

The unit consists of aluminum housing (80x60x20 mm), a keyboard and a micro controller. The keys are made of rubber and have a tactile feel. All LX 7007 PRO IGC units are ready to support the LX Remote without any modification. There are no additional settings needed on the LX 7007 PRO IGC or on the LX Remote. When the remote unit is connected, it is detected automatically when the LX 7007 PRO IGC is switched on.



All keys have only one function; there are no combinations or double functions. All keys correspond 100% to the LX 7007 PRO IGC usage philosophy.

Remote	LX 7007 PRO IGC
• ← MODE MODE →	Mode Selector knob
• ↑ ↓	Up/down selector knob
• ESC,EVENT,ENTER,MC,START	ESC,EVENT,ENTER,MC,START/ON key
• + ZOOM, -ZOOM	ZOOM knob

6.2.1.2 Getting started

The following parts are included:

- LX Remote unit
- Flexible cable with telephone connectors on both ends (can also be purchased in your telephone shop)
- RS485 BUS cable

The RS485-BUS cable consists of 0.5 m cable, 9P SUB D male connector, printed circuit board and a small aluminum plate for fixing. The printed circuit board is normally fixed on the instrument panel. To do that, it is necessary to drill three holes as shown in the picture below.

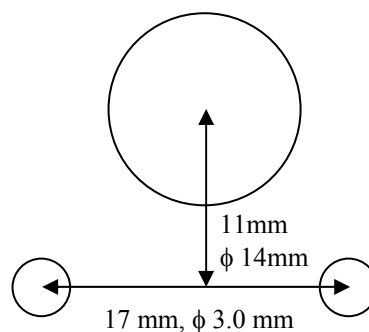

6.2.1.3 Electronic connection

The LX Remote should be connected to the LX 7007 PRO IGC via a free RS485 BUS port on the back of the digital vario (9 P female). If there are no free ports because other devices have been connected, then it is necessary to order a **RS485 Splitting Unit** to split one input into 3 outputs. When the unit is connected correctly, the LX Remote will be detected automatically by the LX 7007 PRO IGC when it is switched on.

6.2.2 LX 7007 PRO IGC – Remote K- Stick mounted unit

6.2.2.1 General

All necessary electronic is built into the top of the stick and only for wires should be provided from the handle tube to the interface unit, this solution makes the installation very easy. Additionally two shielded cables are used for speed command key and PTT.

Note!

Don't forget to initialise speed command input setting to TASTER (SETUP/INPUT)

6.2.2.2 LX 7007 PRO IGC Remote K configuration

There are two units:

- Leather coated stick with built in electronic

Note!

The stick is delivered in two diameters, 20mm and 24 mm. LS gliders requests 24mm, all other glider types will accept 20mm.

- Interface printed circuit board to connecting wires coming from the stick to the LX 7007 485 system bus.

6.2.2.3 Stick handle with keys

The original stick grip should be removed and replaced with the new one. On the top of the new grip there are 9 push buttons. An additional button positioned on the front side is for climb/cruise change over. Both PTT and climb/cruise buttons are wired separate. All remaining buttons are connected to the built in microcontroller and only four wires should be connected to the 485 system bus. A very small interface printed circuit board connects four wires coming out of the stick to the 485 System bus.

Note!

After successfully installation, there is no special setting required on LX 7007 side, a very clear message "REMOTE DETECTED" during booting routine will inform about presence of this interface.



7 Revision history

<i>Apr 2005</i>	1.0 NEW DONE