



November 1990 FORM: OM-135 582B

**MODEL: Robot Interface
(per NSPR 8989)**

OWNER'S MANUAL

IMPORTANT: Read and understand the entire contents of both this manual and the power source manual used with this unit, with special emphasis on the safety material throughout both manuals, before installing, operating, or maintaining this equipment. This unit and these instructions are for use only by persons trained and experienced in the safe operation of welding equipment. Do not allow untrained persons to install, operate, or maintain this unit. Contact your distributor if you do not fully understand these instructions.

MILLER ELECTRIC Mfg. Co.
A Miller Group Ltd., Company

P.O. Box 1079
Appleton, WI 54912 USA
Tel. 414-734-9821

MILLER'S TRUE BLUE™ LIMITED WARRANTY

Effective January 1, 1992
(Equipment with a serial number preface of "KC" or newer)

This limited warranty supersedes all previous MILLER warranties and is exclusive with no other guarantees or warranties expressed or implied.

LIMITED WARRANTY - Subject to the terms and conditions below, MILLER Electric Mfg. Co., Appleton, Wisconsin, warrants to its original retail purchaser that new MILLER equipment sold after the effective date of this limited warranty is free of defects in material and workmanship at the time it is shipped by MILLER. THIS WARRANTY IS EXPRESSLY IN LIEU OF ALL OTHER WARRANTIES, EXPRESS OR IMPLIED, INCLUDING THE WARRANTIES OF MERCHANTABILITY AND FITNESS.

Within the warranty periods listed below, MILLER will repair or replace any warranted parts or components that fail due to such defects in material or workmanship. MILLER must be notified in writing within thirty (30) days of such defect or failure, at which time MILLER will provide instructions on the warranty claim procedures to be followed.

MILLER shall honor warranty claims on warranted equipment listed below in the event of such a failure within the warranty time periods. All warranty time periods start on the date that the equipment was delivered to the original retail purchaser, and are as follows:

1. 5 Years Parts - 3 Years Labor
 - Original main power rectifiers
2. 3 Years - Parts and Labor
 - Transformer/Rectifier Power Sources
 - Plasma Arc Cutting Power Sources
 - Semi-Automatic and Automatic Wire Feeders
 - Robots
3. 2 Years - Parts and Labor
 - Engine Driven Welding Generators
(NOTE: Engines are warranted separately by the engine manufacturer.)
4. 1 Year - Parts and Labor
 - Motor Driven Guns
 - Process Controllers
 - Water Coolant Systems
 - HF Units
 - Grids
 - Spot Welders
 - Load Banks
 - SDX Transformers
 - Running Gear/Trailers
 - Field Options

(NOTE: Field options are covered under True Blue™ for the remaining warranty period of the product they are installed in, or for a minimum of one year - whichever is greater.)
5. 6 Months - Batteries
6. 90 Days - Parts and Labor
 - MIG Guns/TIG Torches
 - Plasma Cutting Torches
 - Remote Controls

- Accessory Kits
- Replacement Parts

MILLER'S True Blue™ Limited Warranty shall not apply to:

1. Items furnished by MILLER, but manufactured by others, such as engines or trade accessories. These items are covered by the manufacturer's warranty, if any
2. Consumable components; such as contact tips, cutting nozzles, contactors and relays
3. Equipment that has been modified by any party other than MILLER, or equipment that has been improperly installed, improperly operated or misused based upon industry standards, or equipment which has not had reasonable and necessary maintenance, or equipment which has been used for operation outside of the specifications for the equipment

MILLER PRODUCTS ARE INTENDED FOR PURCHASE AND USE BY COMMERCIAL/INDUSTRIAL USERS AND PERSONS TRAINED AND EXPERIENCED IN THE USE AND MAINTENANCE OF WELDING EQUIPMENT

In the event of a warranty claim covered by this warranty, the exclusive remedies shall be, at MILLER'S option: (1) repair; or (2) replacement; or, where authorized in writing by MILLER in appropriate cases, (3) the reasonable cost of repair or replacement at an authorized MILLER service station; or (4) payment of or credit for the purchase price (less reasonable depreciation based upon actual use) upon return of the goods at customer's risk and expense. MILLER'S option of repair or replacement will be F O B., Factory at Appleton, Wisconsin, or F O B. at a MILLER authorized service facility as determined by MILLER. Therefore no compensation or reimbursement for transportation costs of any kind will be allowed.

TO THE EXTENT PERMITTED BY LAW, THE REMEDIES PROVIDED HEREIN ARE THE SOLE AND EXCLUSIVE REMEDIES. IN NO EVENT SHALL MILLER BE LIABLE FOR DIRECT, INDIRECT, SPECIAL, INCIDENTAL OR CONSEQUENTIAL DAMAGES (INCLUDING LOSS OF PROFIT), WHETHER BASED ON CONTRACT, TORT OR ANY OTHER LEGAL THEORY.

ANY EXPRESS WARRANTY NOT PROVIDED HEREIN AND ANY IMPLIED WARRANTY, GUARANTY OR REPRESENTATION AS TO PERFORMANCE, AND ANY REMEDY FOR BREACH OF CONTRACT TORT OR ANY OTHER LEGAL THEORY WHICH, BUT FOR THIS PROVISION, MIGHT ARISE BY IMPLICATION, OPERATION OF LAW, CUSTOM OF TRADE OR COURSE OF DEALING, INCLUDING ANY IMPLIED WARRANTY OF MERCHANTABILITY OR FITNESS FOR PARTICULAR PURPOSE, WITH RESPECT TO ANY AND ALL EQUIPMENT FURNISHED BY MILLER IS EXCLUDED AND DISCLAIMED BY MILLER.

Some states in the U.S.A. do not allow limitations of how long an implied warranty lasts, or the exclusion of incidental, indirect, special or consequential damages, so the above limitation or exclusion may not apply to you. This warranty provides specific legal rights, and other rights may be available, but may vary from state to state.

In Canada, legislation in some provinces provides for certain additional warranties or remedies other than as stated herein, and to the extent that they may not be waived, the limitations and exclusions set out above may not apply. This Limited Warranty provides specific legal rights, and other rights may be available, but may vary from province to province.

ERRATA SHEET

After this manual was printed, refinements in equipment design occurred. This sheet lists exceptions to data appearing later in this manual.

AMENDMENT TO SECTION 3 – INSTALLATION

Amend Section 3-5B. ROBOT INTERFACE – WELDING POWER SOURCE CONNECTIONS: REMOTE 17 Connections

3. For units used with Pulstar 450 welding power source, it is necessary to change internal connections in the robot interface. Proceed as follows:



WARNING: ELECTRIC SHOCK can kill.

- Do not touch live electrical parts.
- Shut down unit, welding power source, and robot, and disconnect input power employing lockout/tagging procedures.

Lockout/tagging procedures consist of padlocking line disconnect switch in open position, removing fuses from fuse box, or shutting off and red-tagging circuit breaker or other disconnecting device.

- a. Open front panel access door.
- b. Locate lead 72 at pin F of REMOTE 17 receptacle RC16.
- c. Cut lead 72 as close to receptacle as possible.
- d. Splice lead 72 to lead 77 at REMOTE 14 receptacle RC13 pin D.
- e. Cover splice with electrical tape or other insulation.
- f. Close and secure front panel access door.



CAUTION: WELDING POWER SOURCE may not respond with output corresponding to set value.

- Be sure welding power source main control board has been modified to use a 0 to +10 volt command. See welding power source Owner's Manual for modification procedure.

Add Figure 3-7. Voltage Control Board DIP Switch Setting Label



CAUTION: INCORRECT DVC BOARD DIP SWITCH POSITION can cause equipment malfunction.

- DVC DIP switch is factory set for operation with Deltaweld® 451 welding power source. See Figure 3-7 for DVC DIP switch setting when using another welding power source.

DVC SWITCH SETTINGS							
	S2		S1				
	1	2	1	2	3	4	5
DELTAWELD 300				ON	ON		ON
DELTAWELD 451		O			ON		ON
DELTAWELD 651		O			ON	ON	
MAXTRON 300, 400					ON		ON
MAXTRON 450	ON		ON			ON	
XMT 200/300	ON			ON		ON	
ARC PAK 350	ON			ON		ON	
SHOPMASTER 300				ON	ON		ON
DIMENSION 400		ON	Δ	Δ			ON

O – On For Optional Soft Start. Turn Off S1 -3.
Δ – On For Optional Hot Start.

S-150 864-A

Figure 3-7. DVC DIP Switch Setting Label

Add Section 3-10. SETTING DIP SWITCHES ON VOLTAGE CONTROL BOARD PC1

DIP switch S1 and S2 on voltage control board PC1 allow setting the proper command signal voltage level for controlling voltage output at a welding power source. To change factory set position of DIP switches from a Deltaweld® 451 to another welding power source, proceed as follows:



WARNING: ELECTRIC SHOCK can kill.

- Do not touch live electrical parts.
- Shut down unit, welding power source, and wire feeder, and disconnect input power employing lockout/tagging procedures before setting DIP switches.

Lockout/tagging procedures consist of padlocking line disconnect switch in open position, removing fuses from fuse box, or shutting off and red-tagging circuit breaker or other disconnecting device.

ELECTROSTATIC DISCHARGE (ESD) can damage circuit boards.

- Put on properly grounded wrist strap BEFORE handling circuit boards.
- Transport circuit boards in proper static-shielding carriers or packages.
- Perform work only at a static-safe work area.

1. Loosen screws securing front access door, and open door.
2. Locate voltage control board PC1 in lower left portion of component mounting panel inside robot interface control.
3. Set position of DIP switches S1 and S2 according to label inside unit and Figure 3-7 for appropriate welding power source.
4. Close and secure access door.

Add Section 3-11. VOLTAGE CONTROL BOARD MODIFICATION FOR EARLY MODEL WELDING POWER SOURCE

If the robot interface control is to be used with an early model Deltaweld 450 or 650 welding power source prior to serial number JJ400026, proceed as follows:



WARNING: ELECTRIC SHOCK can kill.

- Do not touch live electrical parts.
- Shut down unit, welding power source, and wire feeder, and disconnect input power employing lockout/tagging procedures before making circuit board modifications.

Lockout/tagging procedures consist of padlocking line disconnect switch in open position, removing fuses from fuse box, or shutting off and red-tagging circuit breaker or other disconnecting device.

ELECTROSTATIC DISCHARGE (ESD) can damage circuit boards.

- Put on properly grounded wrist strap **BEFORE** handling circuit boards.
- Transport circuit boards in proper static-shielding carriers or packages.
- Perform work only at a static-safe work area.

IMPORTANT: A customer-supplied cord (Miller #042 562) is required to connect the welding power source to the weld control.

1. Loosen screws securing front access door, and open door.
2. Locate voltage control board PC1 in lower left portion of component mounting panel inside robot interface control.
3. Mark and disconnect leads from voltage control board PC1.
4. Mark and disconnect plugs from PC1.
5. Note position of circuit board and remove from unit.
6. Place circuit board on a stationary work surface so that component side is facing up.
7. Locate jumpers J1 thru J8 on surface of board (see Figure 3-8).
8. Use a sharp tool to remove sealant coating from all jumper locations, and remove foil jumper between pads at J2, J4, J6, and J8.
9. Apply a small amount of solder to bridge the foil pads at jumper J1, J3, J5, and J7.
10. Apply a sealant coating over all jumper locations.
11. Reinstall circuit board into unit in its original position.
12. Reconnect marked leads and plugs to appropriate locations.

Receptacle RC16 leads 76, 77, and 78 must be changed at plug PLG14 connected to receptacle RC1 on voltage control board PC1 as follows:

IMPORTANT: See receptacle RC1 pin designations etched on circuit board to identify plug openings.

1. Locate and disconnect plug PLG14 from receptacle RC1 on voltage control board PC1.
2. Mark and remove leads 76, 77, and 78 from plug PLG14 by inserting end of a small, flat-tip screwdriver into window on side of plug to bend down locking tab, and pull contact attached to lead from plug.
3. Bend locking tabs on lead contacts out so that they secure contacts when inserted into plug.
4. Insert lead contacts into plug as follows:
 - a. Lead 76 to plug opening 10.
 - b. Lead 77 to plug opening 8.
 - c. Lead 78 to plug opening 9.
5. Reconnect plug PLG14 to receptacle RC1 on voltage control board PC1.
6. Close and secure access door.

Add Figure 3-8. Jumper Locations On Voltage Control Board PC1

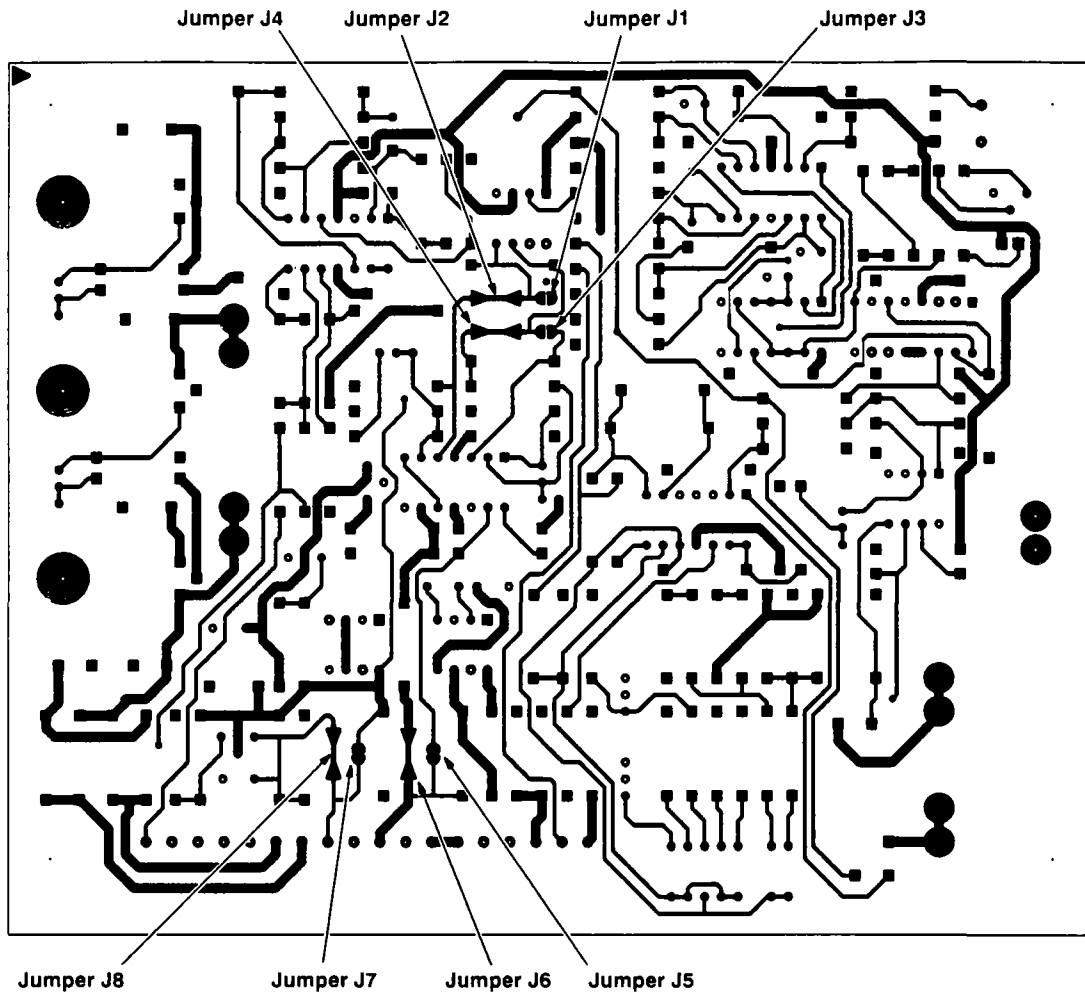

Figure 3-8. Jumper Locations On Voltage Control Board PC1

AMENDMENT TO SECTION 7 – ELECTRICAL DIAGRAMS

Amend Diagram 7-1. Circuit Diagram For Robot Interface (see page 8 on this Errata Sheet)

Delete Diagram 7-2. Circuit Diagram For Voltage Board PC1

This diagram no longer applies effective with Serial No. KC231859

Amend Diagram 7-3. Circuit Diagram For Motor Control Board PC2 (see pages 6 and 7 on this Errata Sheet)

Amend Diagram 7-4. Circuit Diagram For Interface Board PC3 (see page 9 on this Errata Sheet)

AMENDMENT TO SECTION 8 – PARTS LIST

Amend Parts List as follows:

**	Dia. Mkgs.	Part No.	Replaced With	Description	Quantity
19-		028 291	028 291	CAPACITOR, (qty chg & dia. mkg. chg) (C2-4 is now C6-10)	5
	CR4	Added	095 521	RELAY, encl 24VDC 4PDT	1
19-		049 970	048 588	BRACKET, mtg relay	1
19-		079 844	079 844	SPRING, (qty chg)	2
19-		027 811	027 811	SOCKET, (qty chg)	2
19-		048 029	048 029	CLIP, (qty chg)	2
19-		026 202	026 202	DIODE, (qty chg) (added D4)	3
19-	PC1	137 695	148 320	CIRCUIT CARD, (qty chg)	1
19-	PC4	117 836	+149 339	CIRCUIT CARD, meter (Eff w/KB113874)	1
20-	PLG25	Added	117 037	HOUSING, term hdr 2skt	1
20-	RC13	109 768	094 480	RECEPTACLE, 14 pin MS-3102A-20-27P (Eff w/KC217109)	1
20-		111 122	141 162	HOUSING PLUG & PINS, (consisting of)	1
20-			134 731	TERMINAL, male 1 pin sz 16 18-14 wire	14
20-			073 739	CLAMP, cable strain relief sz 17	2
20-		116 964	Deleted	CLAMP, (now incl. w/housing plug & pins)	
20-		111 123	152 370	HOUSING PLUG & SOCKETS, (consisting of)	1
20-			079 534	TERMINAL, female 1skt 18-14 wire	14
20-			079 739	CLAMP, strain relief sz 17	2
21-		072 292	154 098	SHAFT, spool support	1
21-		Added	141 700	RING, retaining ext .625shaft x .050thk (incl. w/hub & spindle ass'y)	1
21-		Added	605 941	WASHER, flat stl .640 ID x 1.0 OD (incl. w/hub & spindle ass'y)	1

**First digit represents page no – digits following dash represent item no.

+Eff w/KB113874. Parts on page 27 may not represent actual board.

BE SURE TO PROVIDE MODEL AND NSPR NUMBER WHEN ORDERING REPLACEMENT PARTS.

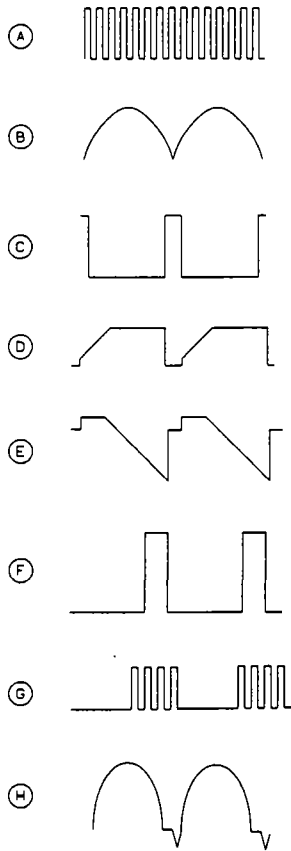

ALL WAVEFORMS AT 300 IPM-MOTOR RUNNING
 ALL VOLTAGES MEASURED WITH RESPECT TO
 COMMON POINT "J". EXCEPT "H"; MEASURE
 "H" WITH RESPECT TO POINT "K".

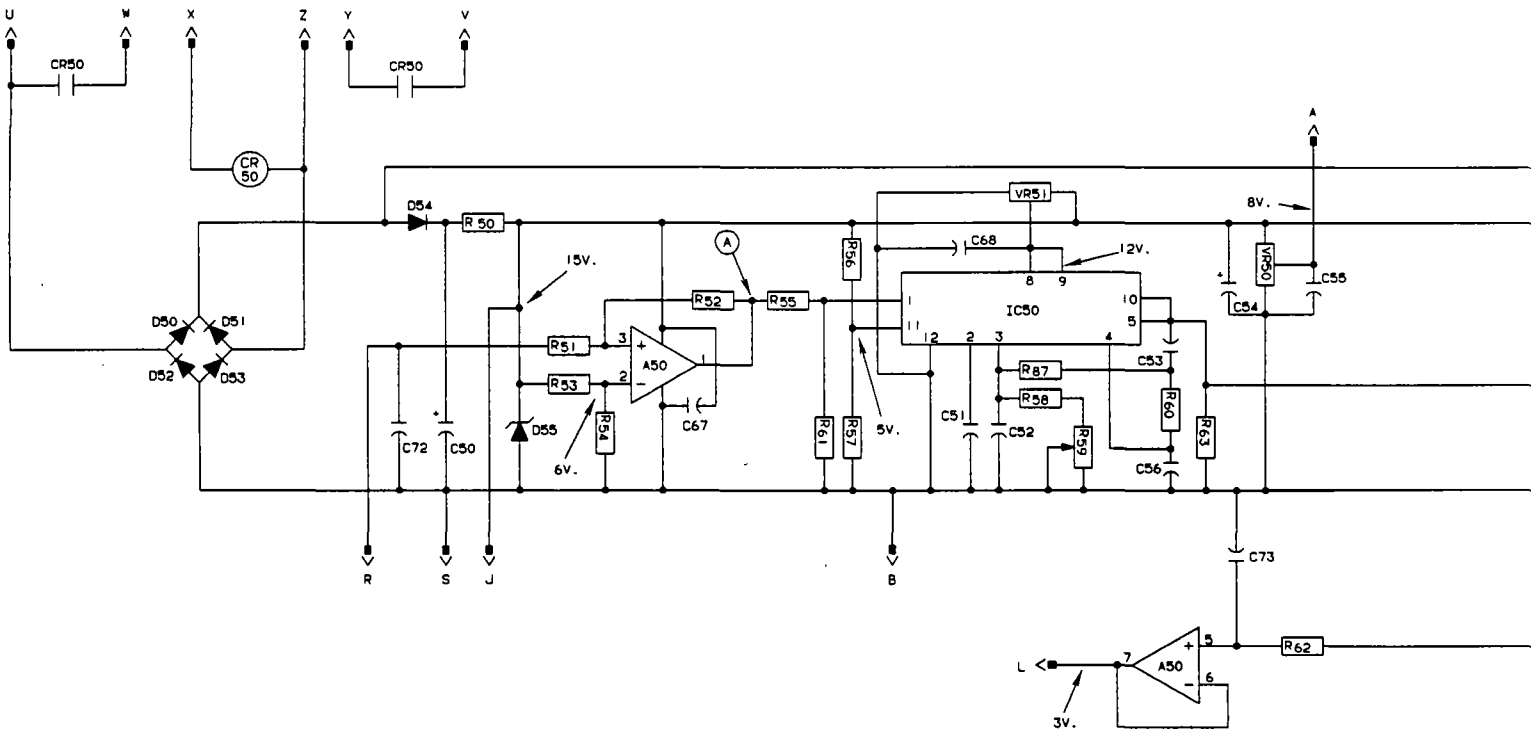
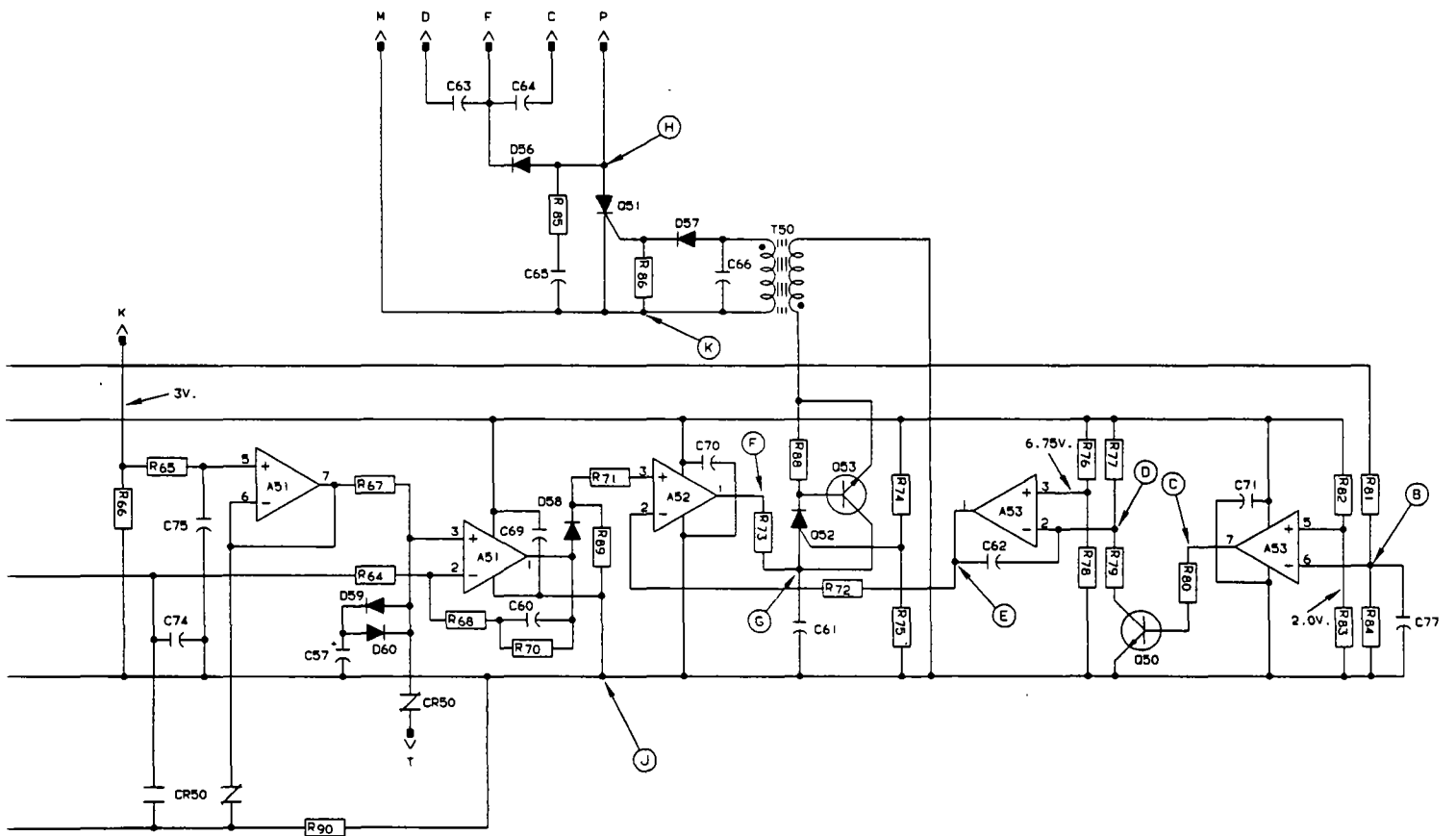
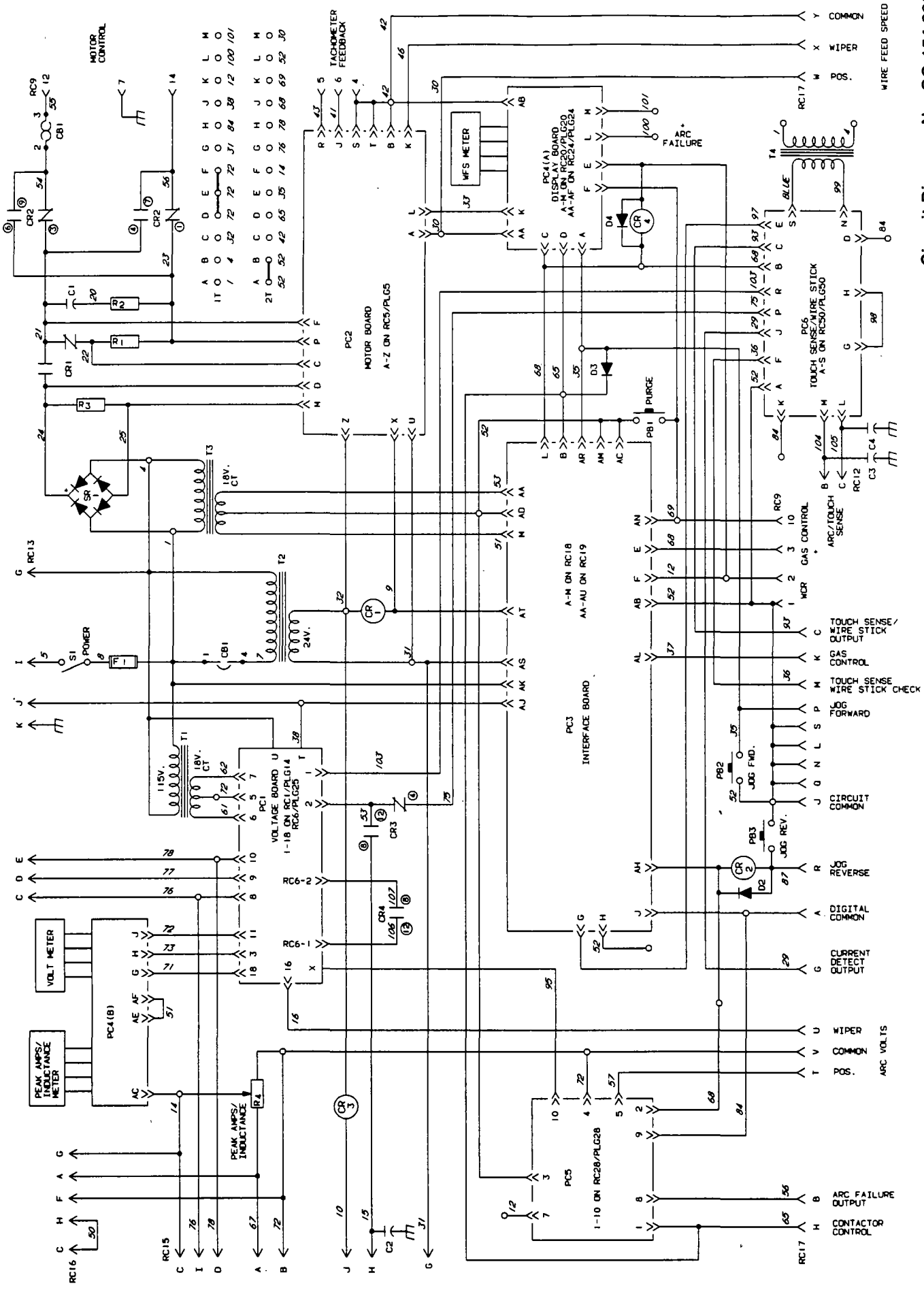

Diagram 7-3. Circuit Diagram For Motor Control Board PC2



Circuit Diagram No. SD-083 388-B



Circuit Diagram No. SC-154 230

Diagram 7-1. Circuit Diagram For Robot Interface Effective With Serial No. KC231859

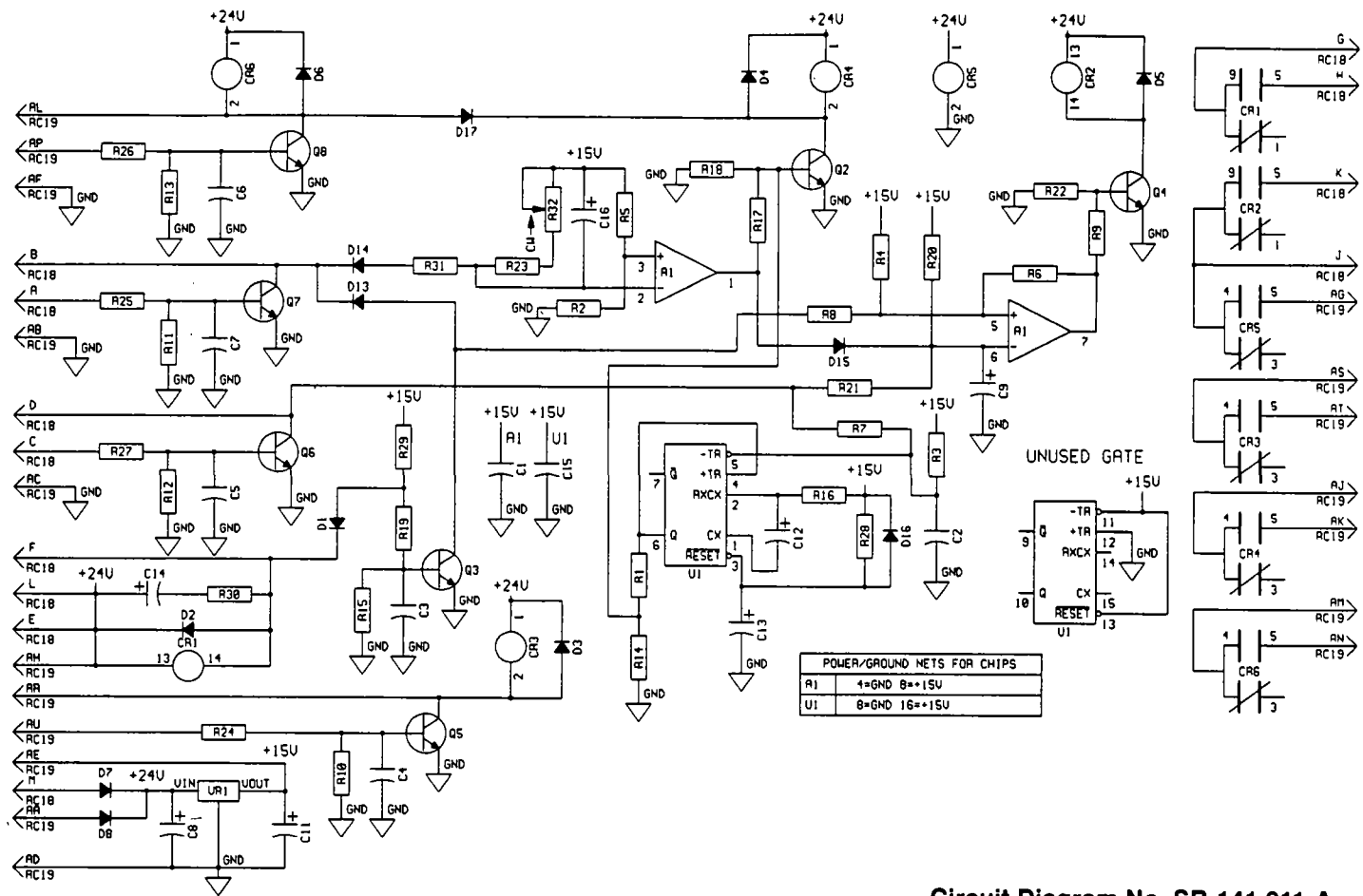

Circuit Diagram No. SB-141 311-A

Diagram 7-4. Circuit Diagram For Interface Board PC3

RECEIVING-HANDLING

Before unpacking equipment, check carton for any damage that may have occurred during shipment. File any claims for loss or damage **with the delivering carrier**. Assistance for filing or settling claims may be obtained from the distributor and/or the equipment manufacturer's Transportation Department.

When requesting information about this equipment, always provide the Model Description and Serial or Style Number.

Use the following spaces to record the Model Designation and Serial or Style Number of your unit. The information is located on the data card or the nameplate.

Model _____

Serial or Style No. _____

Date of Purchase _____

TABLE OF CONTENTS

Section No.	Page No.
SECTION 1 – SAFETY PRECAUTIONS AND SIGNAL WORDS	
1-1. General Information And Safety	1
1-2. Safety Alert Symbol And Signal Words	1
SECTION 2 – SPECIFICATIONS	
2-1. Description	1
SECTION 3 – INSTALLATION	
3-1. Site Selection	2
3-2. Equipment Installation	2
3-3. Gas/Current Sensing Control Interconnections	3
3-4. Voltage Sensing Connections	3
3-5. Robot Interface – Welding Power Source Connections	4
3-6. Robot Interface – Robot Control Unit Connections	4
3-7. Arc Failure Light Terminal Strip Connections	5
3-8. Welding Wire Installation	6
3-9. Burnback Control	6
SECTION 4 – OPERATOR CONTROLS	
4-1. Power Switch	7
4-2. Jog Push Buttons	7
4-3. Purge Push Button	7
4-4. Voltmeter	7
4-5. Wire Speed Meter	7
4-6. Amps/Inductance Meter	7
4-7. Indicator Lights	7
SECTION 5 – SEQUENCE OF OPERATION	
5-1. Input Signals From Robot Control Unit	8
5-2. Output Signals From Robot Interface	8

SECTION 6 – MAINTENANCE & TROUBLESHOOTING

6-1. Routine Maintenance	8
6-2. Overload Protection	9
6-3. Reinstallation Of Hub Assembly	9
6-4. Display Board PC4 Meter Check	9
6-5. Circuit Board Handling Precautions	10
6-6. Troubleshooting	11
6-7. Use Of Indicator Lights For Troubleshooting	13

SECTION 7 – ELECTRICAL DIAGRAMS

Diagram 7-1. Circuit Diagram For Robot Interface	14
Diagram 7-2. Circuit Diagram For Voltage Board PC1	15
Diagram 7-3. Circuit Diagram Motor Control Board PC2	16
Diagram 7-4. Circuit Diagram For Interface Board PC3	17
Diagram 7-5. Circuit Diagram For Display Board PC4	17
Diagram 7-6. Circuit Diagram For Arc Failure Board PC5	18
Diagram 7-7. Circuit Diagram For Touch Sense/Wire Stick Board PC6	18

SECTION 8 – PARTS LIST

Figure 8-1. Circuit Card, Voltage Control PC1	22
Figure 8-2. Circuit Card, Motor Speed Digital PC2	24
Figure 8-3. Circuit Card, Interface PC3	26
Figure 8-4. Circuit Card, Meter PC4	27
Figure 8-5. Circuit Card, Interface PC5	28
Figure 8-6. Circuit Card, Wire Touch PC6	29

LIST OF CHARTS AND TABLES

Table 2-1. Specifications	1
Table 6-1. Troubleshooting	12

SECTION 1 – SAFETY PRECAUTIONS AND SIGNAL WORDS

1-1. GENERAL INFORMATION AND SAFETY

A. General

Information presented in this manual and on various labels, tags, and plates on the unit pertains to equipment design, installation, operation, maintenance, and troubleshooting which should be read, understood, and followed for the safe and effective use of this equipment.

B. Safety

The installation, operation, maintenance, and troubleshooting of arc welding equipment requires practices and procedures which ensure personal safety and the safety of others. Therefore, this equipment is to be installed, operated, and maintained only by qualified persons in accordance with this manual and all applicable codes such as, but not limited to, those listed at the end of Section 1 – Safety Rules For Operation Of Arc Welding Power Source in the welding power source Owner's Manual.

1-2. SAFETY ALERT SYMBOL AND SIGNAL WORDS

The following safety alert symbol and signal words are used throughout this manual to call attention to and identify different levels of hazard and special instructions.



This safety alert symbol is used with the signal words **WARNING** and **CAUTION** to call attention to the safety statements.



WARNING statements identify procedures or practices which must be followed to avoid serious personal injury or loss of life.



CAUTION statements identify procedures or practices which must be followed to avoid minor personal injury or damage to this equipment.

IMPORTANT statements identify special instructions necessary for the most efficient operation of this equipment.

SECTION 2 – SPECIFICATIONS

Table 2-1. Specifications

Component	Dimensions			Weight	
	Height	Width	Depth	Net	Ship
Robot Interface	22-1/2 in. (572 mm)	16-1/2 in. ♦ (419 mm)	6-1/4 in.* (159 mm)	38 lbs. (17 kg)	Total 61 lbs. (27.7 kg)
Gas/Current Sensing Control	4-1/2 in. (108 mm)	5-1/2 in. (140 mm)	10-1/2 in. (267 mm)	5 lbs. (2.3 kg)	
Spool Support Assembly+	13-3/4 in. (349 mm)	8-3/4 in. (222 mm)	8-1/2 in. (216 mm)	6 lbs. (2.7 kg)	
♦ Add 2-1/4 in. (57 mm) for brake resistor. * Add 7/8 in. (22 mm) for front panel knob.			+ Spool Support without optional wire reel.		

2-1. DESCRIPTION

The robot interface control is designed to interface with a Panasonic robot and an Arc Pak 350, Deltaweld, Maxtron, or Pulstar 450 welding power source. This unit provides digital display of weld volts, wire feed speed,

and peak amperage or inductance.

The gas/current sensing control contains the gas valve and current sensing reed relay.

These components function with the robot system when using the Gas Metal Arc Welding (GMAW) process.

SECTION 3 – INSTALLATION

3-1. SITE SELECTION

Select an installation site which provides the following:

1. Correct input power supply (see unit nameplate)
2. Shielding gas supply (if applicable)
3. Water supply (if applicable)
4. Adequate ventilation and fresh air supply
5. No flammables
6. A clean and dry area
7. Proper temperature that avoids extremes of heat or cold
8. Proper airflow around unit
9. Adequate space to open and remove cover and wrapper for installation, maintenance, and repair functions.

Mounting holes provide the capability to install and secure the system components in a permanent location. Table 2-1 gives overall dimensions.

3-2. EQUIPMENT INSTALLATION

A. Supplied Equipment

The following equipment is supplied as standard and requires installation or assembly:

1. Weld Control with Gas/Current Sensing Control Cord and Motor Cord
2. Gas/Current Sensing Control
3. Hub and Spindle Assembly
4. Spindle Support
5. 10 ft. (3 m) Weld Control – Welding Power Source Interconnecting Cords
6. 10 ft. (3 m) Gas Hose
7. 10 ft. (3 m) Voltage Sensing Cord

B. Equipment Location

When deciding on equipment location, consider the following:

1. The equipment must be mounted to a structure capable of supporting the weight of the equipment.
2. The lead lengths of the cords supplied with the equipment will limit the area in which the equipment can be located. Some cords can be extended by using optional extension cords (check with welding equipment distributor).

3. The interconnecting cords must be routed so that they are not caught, pinched, or strained during welding operations.
4. One weld output cable must be routed to the Gas/Current Sensing control.
5. Welding wire must be routed so that it does not contact the weld control or any other grounded equipment.

C. Equipment Installation

Obtain appropriate mounting brackets or adapter plates as necessary and mounting hardware. Prepare structure for equipment installation. Secure weld control, Gas/Current Sensing control, and all other equipment onto structures in the welding area.

D. Hub Installation (Figure 3-1)

The hub assembly is supplied with the robot interface. Remove the hub assembly from the shipping carton, and install it as follows:

1. Remove hex nut from end of hub support shaft.
2. Align keyway and insert hub support shaft through selected hole in hub support. Hole selection in hub support depends on wire spool size. Be sure the brake washers are properly seated in the hub.
3. Reinstall hex nut onto support shaft. Tighten hex nut until a slight drag is felt while turning hub.
4. Install welding wire according to Section 3-8.

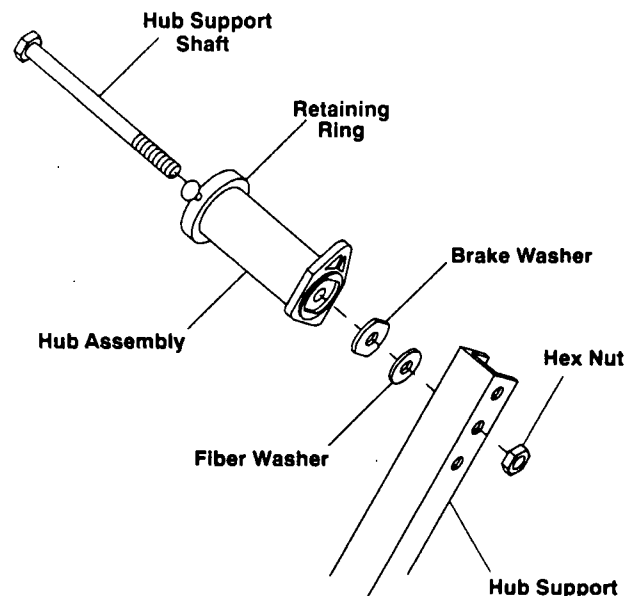

SA-126 870

Figure 3-1. Hub Assembly Installation

3-3. GAS/CURRENT SENSING CONTROL INTERCONNECTIONS (Figure 3-2)



WARNING: ELECTRIC SHOCK can kill.

- Do not touch live electrical parts.
- Shut down unit, welding power source, and robot, and disconnect input power employing lockout/tagging procedures before making interconnections.

Lockout/tagging procedures consist of padlocking line disconnect switch in open position, removing fuses from fuse box, or shutting off and red-tagging circuit breaker or other disconnecting device.

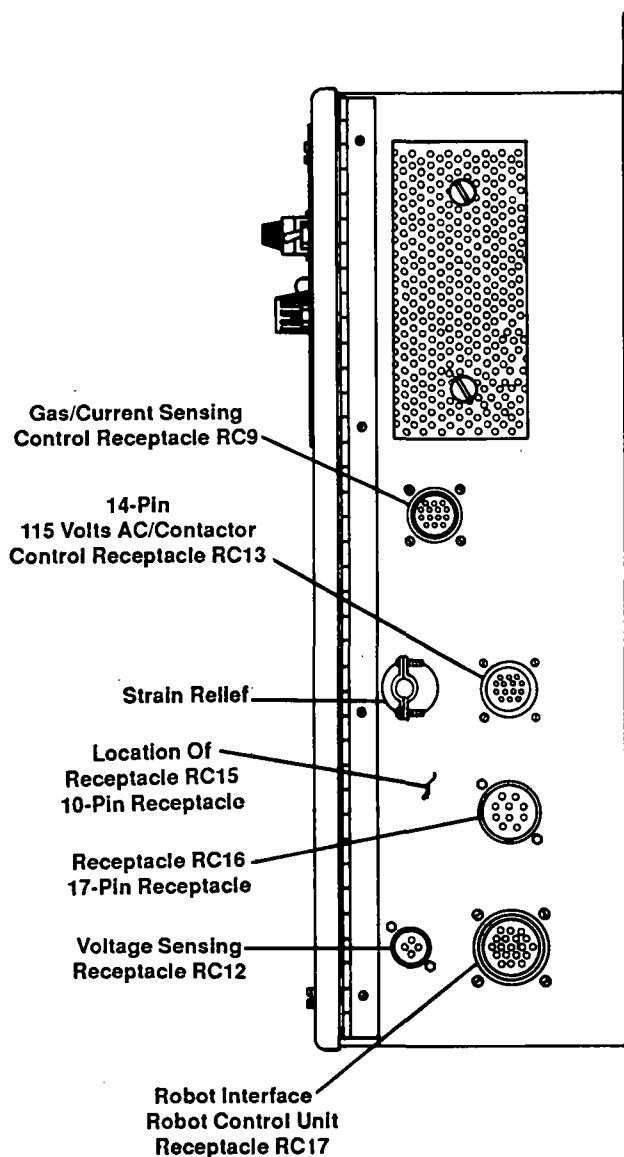

TB-119 646

Figure 3-2. Right Side View

There are several cords supplied for gas/current sensing control interconnections. Examine and select the proper cord for the following connections.

A. Robot Interface – Gas/Current Sensing Control Connections

1. Align keyways, insert 14-pin Amp plug into matching receptacle RC9 on robot interface, and rotate threaded collar fully clockwise.
2. Align keyways, insert 16-pin Amp plug into matching receptacle RC16 on gas/current sensing control, and rotate threaded collar fully clockwise.

B. Gas/Current Sensing Control – Motor Connections

1. Align keyways, insert 14-pin plug from motor cord into matching receptacle RC7 on gas/current sensing control, and rotate threaded collar fully clockwise.
2. Align keyways, insert 14-socket plug from motor control cord into matching free-hanging receptacle from motor, and rotate threaded collar fully clockwise.

C. Weld Cable Connections

For Electrode Positive/Reverse Polarity, route cable from welding power source POSITIVE weld output terminal, through the gas/current sensing control, to the wire drive assembly, and connect cable to weld cable terminal (see Motor/Drive Assembly Owner's Manual for location).

D. Gas Connections

Connect hose from gas regulator/flowmeter (customer supplied) at gas source to IN fitting on gas/current sensing control. Connect gas hose from wire drive assembly to fitting on gas/current sensing control. The gas flow must be accurately controlled by a regulator/flowmeter at the source.

3-4. VOLTAGE SENSING CONNECTIONS (Figures 3-2 And 3-3)



WARNING: ELECTRIC SHOCK can kill.

- Do not touch live electrical parts.
- Shut down unit, welding power source, and robot, and disconnect input power employing lockout/tagging procedures before making interconnections.

Lockout/tagging procedures consist of padlocking line disconnect switch in open position, removing fuses from fuse box, or shutting off and red-tagging circuit breaker or other disconnecting device.

1. Align keyway, insert 4-socket plug into matching receptacle RC12 on robot interface, and rotate threaded collar fully clockwise.
2. Connect lead with ring terminal to weld cable terminal on the wire drive assembly as shown in Figure 3-3.
3. Connect lead with clamp to workpiece.

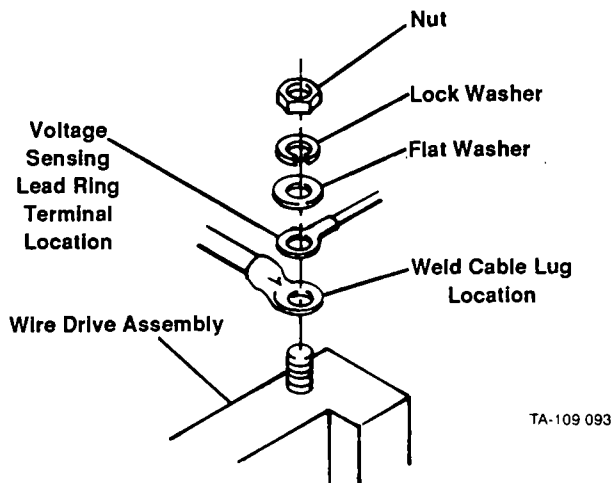

Figure 3-3. Voltage Sensing Connections At Wire Drive Assembly

3-5. ROBOT INTERFACE – WELDING POWER SOURCE CONNECTIONS (Figure 3-2)

There are three cords supplied for interconnections between the robot interface and welding power source. Examine and select the proper cords for the following connections.

A. REMOTE 14 Connections

1. Align keyway, insert 14-socket plug into matching receptacle RC13 on robot interface, and rotate threaded collar fully clockwise.
2. Align keyway, insert 14-pin plug into matching receptacle on welding power source, and rotate threaded collar fully clockwise.

B. REMOTE 17 Connections

1. Align keyway, insert 17-socket plug into matching receptacle RC16 on robot interface, and rotate threaded collar fully clockwise.
2. Align keyway, insert 17-pin plug into matching receptacle on welding power source, and rotate thread collar fully clockwise.

C. REMOTE 10 Connections

1. Align keyway, insert 10-socket plug into matching receptacle RC15 on robot interface, and rotate threaded collar fully clockwise.
2. Align keyway, insert plug into matching receptacle on the welding power source, and rotate threaded collar fully clockwise.

If the welding power source is equipped with a 14/17 switch, be sure the switch is in the 14 position, even though connections are made to both REMOTE 14 and REMOTE 17 receptacles.

3-6. ROBOT INTERFACE – ROBOT CONTROL UNIT CONNECTIONS (Figures 3-2 And 3-4)



WARNING: ELECTRIC SHOCK can kill.

- Do not touch live electrical parts.
- Shut down unit, welding power source, and robot, and disconnect input power employing lockout/tagging procedures before making interconnections.

Lockout/tagging procedures consist of padlocking line disconnect switch in open position, removing fuses from fuse box, or shutting off and red-tagging circuit breaker or other disconnecting device.

1. Obtain a proper cord and 24-pin Amphenol plug (not supplied).
2. Connect conductors at one end of cord to appropriate sockets in plug.
3. Align keyway, insert 24-pin plug into matching receptacle on robot interface, and rotate threaded collar fully clockwise.
4. Route and connect conductors at remaining end of cord to the robot control unit.

The input and output signals at the sockets of receptacle RC17 by means of the robot interface control circuitry are as follows:

- Socket A: Digital common for output signals at Sockets B, C, and G.
- Socket B: Arc failure output signal.
- Socket C: Touch Sense/Wire stick output signal.
- Socket G: Current detect output signal.
- Socket H: Weld start input signal.
- Socket J: Circuit Common for Sockets H, K, M, P, and R; all circuit voltages referenced to this point.
- Socket K: Gas valve input signal.
- Socket L: Circuit common for input signals at Sockets H, K, M, P, and R
- Socket M: Touch Sense/Wire stick input signal.
- Socket N: Circuit common for input signals at Sockets H, K, M, P, and R
- Socket P: Wire inch positive (+) input signal.
- Socket Q: Circuit common for input signals at Sockets H, K, M, P, and R.
- Socket R: Wire inch negative (-) input signal.
- Socket S: Circuit common for input signals at Sockets H, K, M, P, and R
- Socket T: Voltage control positive (+) connection.
- Socket U: Voltage control wiper connection.

- Socket V: Voltage control negative (-) connection.
- Socket W: Wire feed speed positive (+) connection.
- Socket X: Wire feed speed wiper connection.
- Socket Y: Wire feed speed negative (-) connection.

IMPORTANT: *The remaining sockets in the receptacle are not used.*

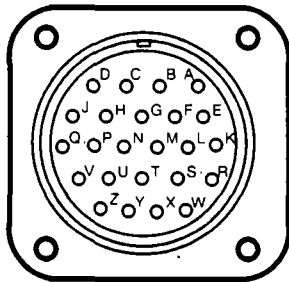

S-0291

Figure 3-4. Front View Of 24-Socket Amphenol Receptacle With Socket Designations

3-7. ARC FAILURE LIGHT TERMINAL STRIP CONNECTIONS (Figure 3-5)



WARNING: ELECTRIC SHOCK can kill.

- Do not touch live electrical parts.
- Shut down unit, welding power source, and robot, and disconnect input power employing lockout/tagging procedures before making interconnections.

Lockout/tagging procedures consist of padlocking line disconnect switch in open position, removing fuses from fuse box, or shutting off and red-tagging circuit breaker or other disconnecting device.

There are two terminal strips inside the robot interface for control connections. Loosen screws on strain relief on unit right side panel if applicable, open front panel access door, and locate appropriate terminal strip for connections. Tighten screws on strain relief if necessary, and close and secure front panel access door when procedure is finished.

The ARC FAILURE light on the robot interface front panel is turned on and off by a signal from the robot control unit. Obtain proper length of 18 gauge/2-conductor cord for this connection, and proceed as follows:

1. For robot control units when 24 vdc is used (Figure 3-5):
 - a. Route cord through strain relief on right side panel of robot interface, and make proper connections to 1TL and 1TM.
 - b. Route and connect remaining end of cord to weld alarm terminal and ground connection at the robot control unit.
 - c. Connect +24 vdc to common relay contact terminal.

2. For robot control units when 115 or 24 vac, or 24 vdc is used (Figure 3-5):
 - a. Route cord through strain relief on right side panel of robot interface, and make proper connections to 1TL and 1TM.
 - b. Obtain a 115 or 24 vac, or 24 vdc isolation relay CR1, and install into robot control.
 - c. Route and connect remaining end of cord to one side of the normally-open robot control relay contact and ground.
 - d. Connect +24 vdc to remaining side of normally-open robot control relay contact.
 - e. Connect a lead from one side of robot control coil to weld alarm terminal.
 - f. Connect proper voltage source (115 vac, 24 vac, or 24 vdc) between common terminal and remaining side of robot control relay coil.

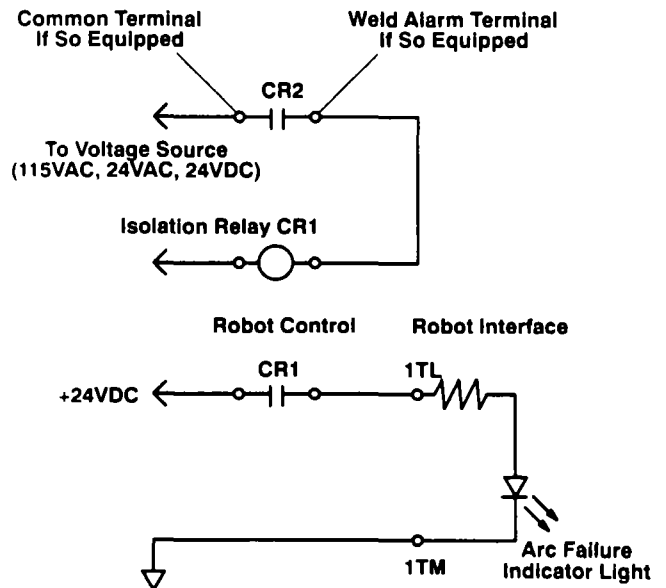
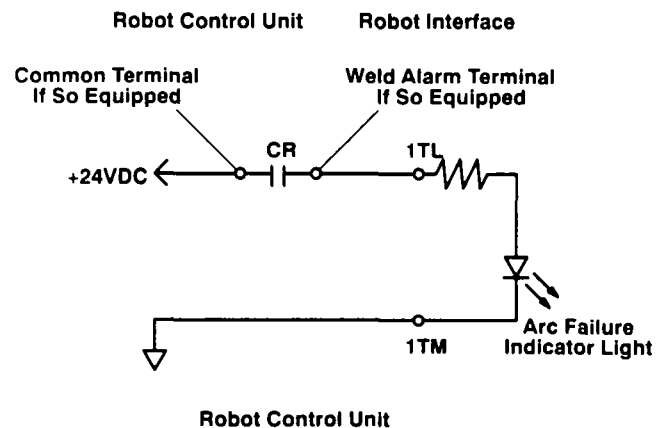

S-0292

Figure 3-5. Arc Failure Light Connections

3-8. WELDING WIRE INSTALLATION (Figure 3-6)

A. Installation Of Spool-Type Wire

1. Remove retaining ring.
2. Slide spool of wire onto hub so that wire feeds off bottom of spool.
3. Rotate spool until hole in spool aligns with pin in hub. Slide spool onto hub until it seats against back flange of the hub.
4. Reinstall retaining ring onto hub.

B. Installation Of Optional Wire Reel And Reel-Type Wire

1. Remove retaining ring and, if applicable, wire reel assembly from hub.
2. Lay wire reel assembly flat on a table or floor.
3. Remove spanner nut from wire reel assembly.
4. Remove wire retainer, and install wire onto wire reel. Be sure that wire feeds off bottom of reel.
5. Reinstall wire retainer and spanner nut onto wire reel.
6. Slide wire reel assembly onto hub, and rotate assembly until hub guide pin is seated in reel.
7. Reinstall retaining ring onto hub.

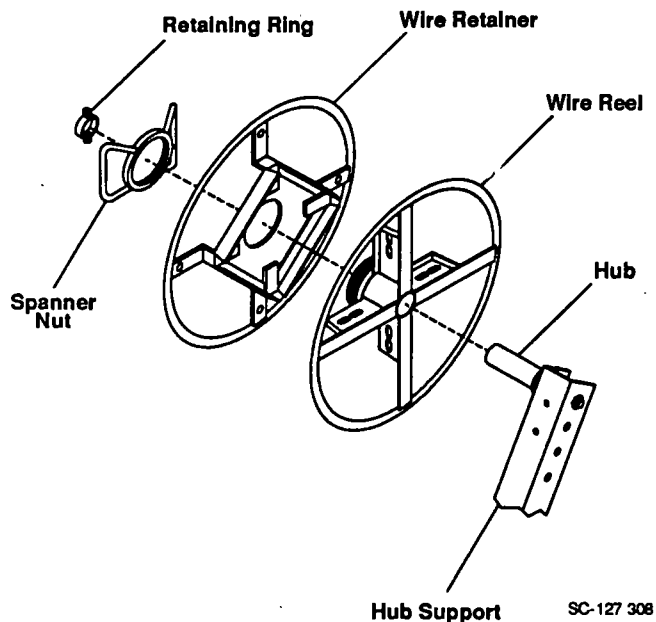

Figure 3-6. Optional Wire Reel And Reel-Type Wire Installation

C. Adjustment Of Hub Tension (Figure 3-1)

Check the hub tension by slowly rotating the wire spool or reel. The wire should unwind freely, but hub tension should be sufficient to keep wire taut and prevent backlash when the wire feed stops. If adjustment is required, loosen or tighten the hex nut on the end of the hub support shaft accordingly.

3-9. BURNBACK CONTROL

Burnback is provided by potentiometer R32 on Interface Circuit Board PC3 inside the unit. Burnback can be set between 0 and 0.25 seconds.

The burnback circuitry in this unit keeps the welding wire from sticking to the workpiece after the arc is extinguished. The burnback circuitry keeps weld output on the welding wire from 0 to 0.25 seconds after the wire has stopped feeding. This delay action permits the welding wire to burn back to a point where it neither sticks to the workpiece or the contact tube.



WARNING: ELECTRIC SHOCK can kill.

- Do not touch live electrical parts.
- Shut down unit, welding power source, and robot, and disconnect input power employing lockout/tagging procedures before inspecting or installing.

Lockout/tagging procedures consist of padlocking line disconnect switch in open position, removing fuses from fuse box, or shutting off and red-tagging circuit breaker or other disconnecting device.



CAUTION: ELECTROSTATIC DISCHARGE (ESD) can damage circuit boards.

- Put on properly grounded wrist strap BEFORE handling circuit boards.
- Perform work only at a static-safe work area.

1. Open front access door and locate PC3.
2. Locate potentiometer R32 in upper left corner of PC3.
3. Rotate R32 clockwise to increase burnback time.
4. Close and secure front access door.

SECTION 4 – OPERATOR CONTROLS

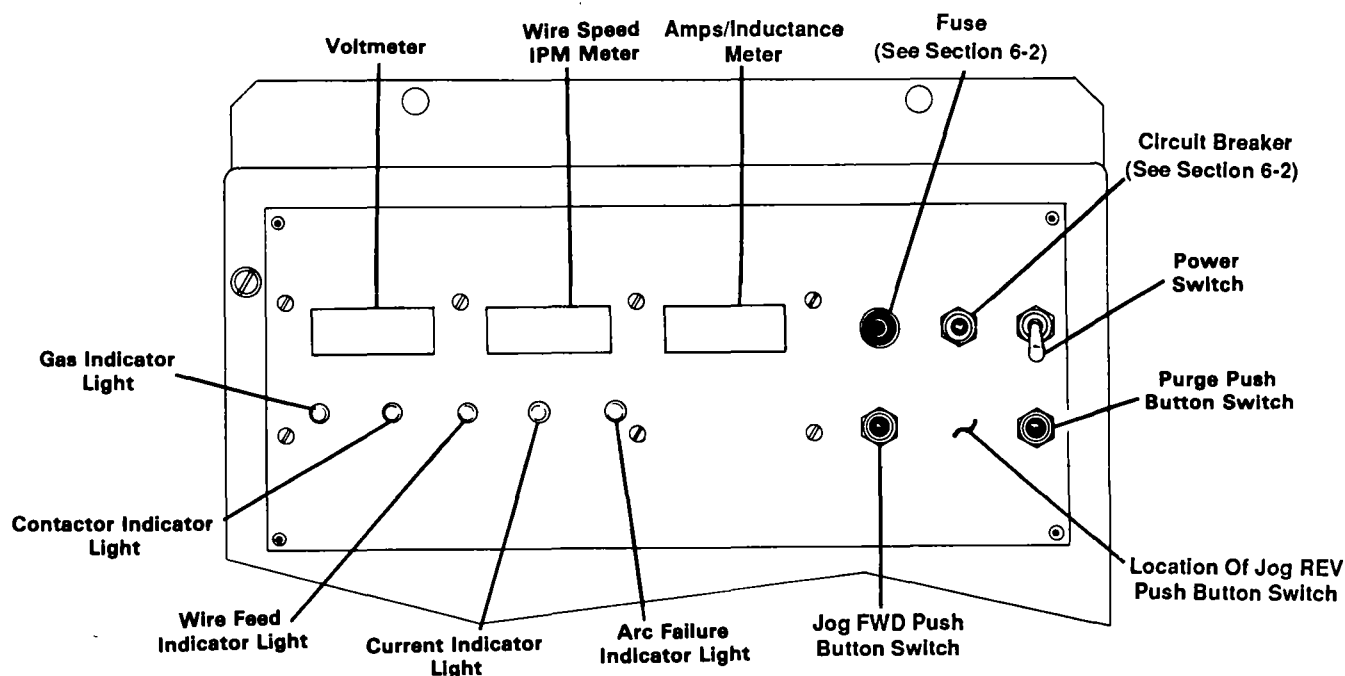

Ref. TB-119 645

Figure 4-1. Front Panel Controls

4-1. POWER SWITCH (Figure 4-1)

Placing the POWER switch in the ON position energizes the robot interface. The interface must be on for the robot to weld. Placing the POWER switch in the OFF position shuts down the interface.

4-2. JOG PUSH BUTTONS (Figure 4-1)

The JOG push buttons are momentary-contact switches. When the JOG FWD switch is pushed, welding wire feeds out of the gun. When the JOG FWD and JOG REV. buttons are pushed, welding wire feeds back into the gun.

4-3. PURGE PUSH BUTTON (Figure 4-1)

The PURGE push button is a momentary-contact switch. This switch energizes the gas solenoid and purges the shielding gas line of the gun. The PURGE push button allows the flow meter to be adjusted without energizing the welding circuit.

4-4. VOLTMETER (Figure 4-1)

The voltmeter displays weld voltage to the nearest tenth of a volt while welding and preset voltage while idling.

4-5. WIRE SPEED METER (Figure 4-1)

The wire speed meter displays preset wire feed speed to the nearest inch per minute while welding and idling. Ac-

tual and preset wire feed speed are the same due to the wire feed speed feedback circuit.

4-6. AMPS/INDUCTANCE METER (Figure 4-1)

When used with the Pulstar welding power source, the meter displays weld peak amperage.

When used with the Arc Pak welding power source, the meter displays inductance in percentage.

When used with the Deltaweld welding power source, this meter is blank.

4-7. INDICATOR LIGHTS (Figure 4-1)

There are five indicator lights on the interface. These are visual indications of various process functions.

The GAS light turns on when the gas valve is energized to indicate shielding gas flow.

The CONTACTOR light turns on when the welding power source contactor is energized to indicate that weld output is available.

The WIRE FEED light turns on when the wire drive motor is energized to indicate that wire is feeding.

The CURRENT light turns on when the current detect relay is energized to indicate that an arc is established.

The ARC FAILURE light turns on only when properly connected according to instructions in Section 3-6, and there is an arc outage while welding.

SECTION 5 – SEQUENCE OF OPERATION

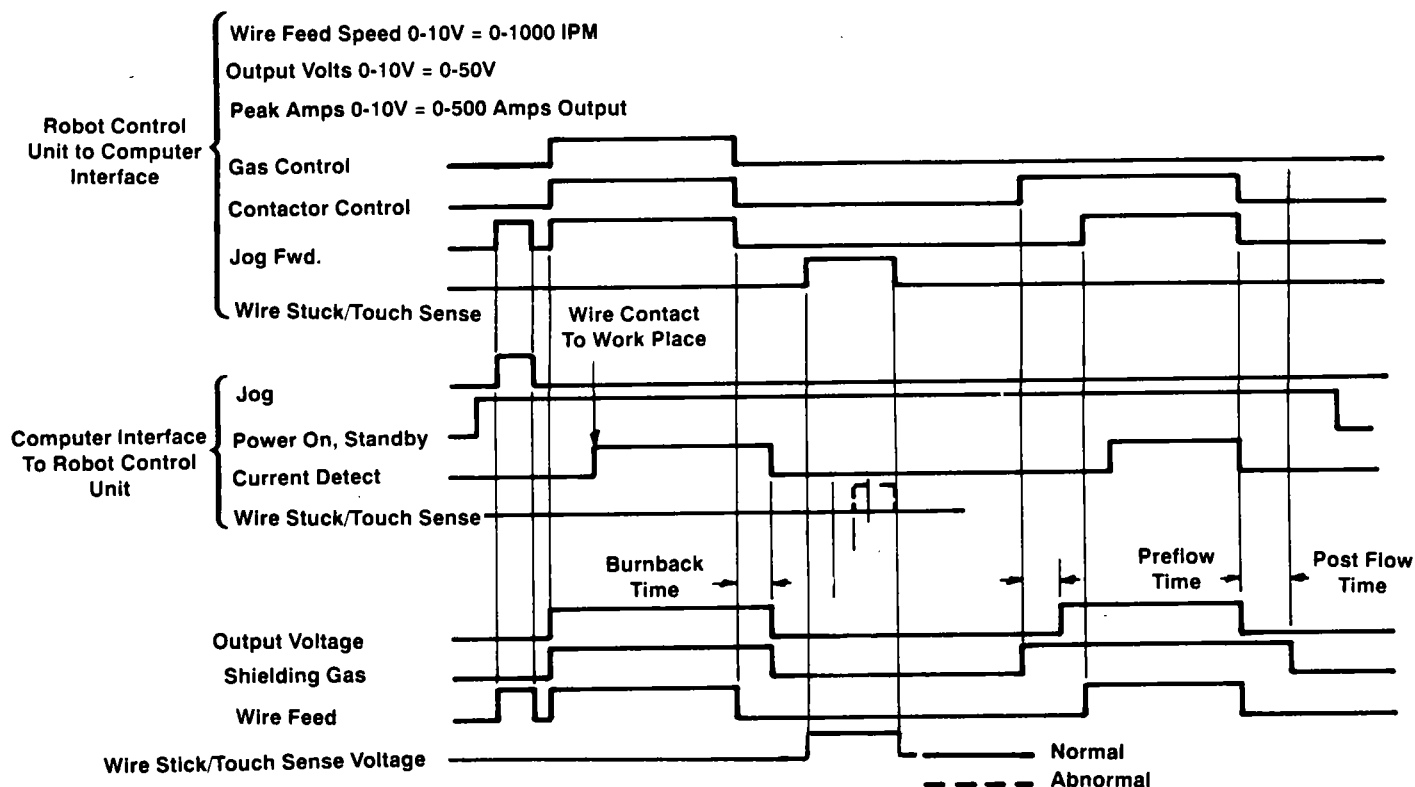

TA-094 382-A

Figure 5-1. Input And Output Signal Timing Chart

5-1. INPUT SIGNALS FROM ROBOT CONTROL UNIT (Figure 5-1)

The robot interface receives input signals for contactor control, gas control, jog, welding volts, wire speed, and current. It also receives a signal to initiate a check to see

if the wire is stuck to the workpiece at the end of the weld.

5-2. OUTPUT SIGNALS FROM ROBOT INTERFACE (Figure 5-1)

The robot interface sends output signals to the robot control unit for current sense, wire stuck, and arc failure.

SECTION 6 – MAINTENANCE & TROUBLESHOOTING

6-1. ROUTINE MAINTENANCE

IMPORTANT: *Every six months inspect the labels on this unit for legibility. All precautionary labels must be maintained in a clearly readable state and replaced when necessary. See Parts List for part number of precautionary labels.*

Usage and shop conditions determine the frequency and type of maintenance. At minimum, inspect equipment every three months as follows:



WARNING: ELECTRIC SHOCK can kill.

- Do not touch live electrical parts.
- Shut down unit, welding power source, and robot, and disconnect input power employing lockout/tagging procedures before inspecting, maintaining, or servicing.

Lockout/tagging procedures consist of padlocking line disconnect switch in open position, removing fuses from fuse box, or shutting off and red-tagging circuit breaker or other disconnecting device.

MOVING PARTS can cause serious injury.

- *Keep away from moving parts.*

HOT SURFACES can cause severe burns.

- *Allow cooling period before servicing.*

Maintenance to be performed only by qualified persons.

1. Repair or replace, as required, all hose and cable; give particular attention to frayed and cracked insulation and areas where it enters equipment.
2. Remove grease and grime from components; moisture from electrical parts and cable.

6-2. OVERLOAD PROTECTION



WARNING: ELECTRIC SHOCK can kill.

- *Do not touch live electrical parts.*
- *Shut down unit, welding power source, and robot, and disconnect input power employing lockout/tagging procedures before inspecting, maintaining, or servicing.*

Lockout/tagging procedures consist of padlocking line disconnect switch in open position, removing fuses from fuse box, or shutting off and red-tagging circuit breaker or other disconnecting device.

INCORRECT FUSE can damage unit.

- *Use only replacement fuse of same size, type, and rating (see Parts List).*

A. Wire Drive Motor Circuit Breaker CB1 (Figure 4-1)



WARNING: Read and follow safety information at beginning of Section 6-2 before proceeding.

Circuit breaker CB1 protects the wire drive motor from overload. If CB1 opens, the wire feed motor would stop.

Should a motor overload occur and CB1 open, proceed as follows:

1. Check for jammed wire or clogged gun liner, and correct problem. If wire jams often, replace gun liner.
2. If motor overload occurs often, repair or replace wire drive motor.
3. Check for binding drive gear or misaligned drive rolls, and correct problem.
4. Reset circuit breaker by depressing the button. A cooling period may be necessary before the circuit breaker can be reset.
5. Resume operation.

B. Main Fuse F1 (Figure 4-1)



WARNING: Read and follow safety information at beginning of Section 6-2 before proceeding.

Fuse F1 protects the robot interface from an internal short or excessive overload. If fuse F1 opens, the robot

interface shuts down. If the fuse opens, correct the problem and replace F1 as follows:

1. Depress and rotate fuse holder cover counterclockwise.
2. Pull out fuse with cover when fuse holder cover is free.
3. Insert new fuse into fuse holder cover.
4. Install fuse with fuse holder cover back into unit.
5. Depress and rotate fuse holder cover clockwise until cover is secure.

6-3. REINSTALLATION OF HUB ASSEMBLY (Figure 6-1)

If it becomes necessary to replace part or all of the hub assembly, reinstall the new hub assembly as follows:

1. Remove hub assembly from hub support, and disassemble discarding worn or broken parts.
2. Slide the following items onto the hub support shaft in order given.
 - a. Spring
 - b. Keyed Washer
 - c. Fiber Washer
 - d. Brake Washer
 - e. Hub
 - f. Brake Washer
 - g. Fiber Washer
3. Align keyway, and insert hub support shaft through selected hole in hub support.
4. Install hex nut onto hub support shaft. Tighten hex nut until a slight drag is felt while turning hub.
5. Install welding wire according to Section 3-8.

6-4. DISPLAY BOARD PC4 METER CHECK (Figure 6-2)

Check points are provided on the display board PC4 for checking power supply and input command for the meters.



WARNING: ELECTRIC SHOCK can kill.

- *Do not touch live electrical parts.*
- *Be sure that personnel performing testing procedures are familiar with and follow standard safety practices.*
- *Shut down unit before making or changing meter or test equipment lead connections.*

ELECTROSTATIC DISCHARGE (ESD) can damage electronic components.

- *Put on a properly grounded wrist strap BEFORE handling circuit boards.*
- *Transport all static-sensitive components in proper static-shielding carriers and packages.*
- *Perform work only at a static-safe work area.*

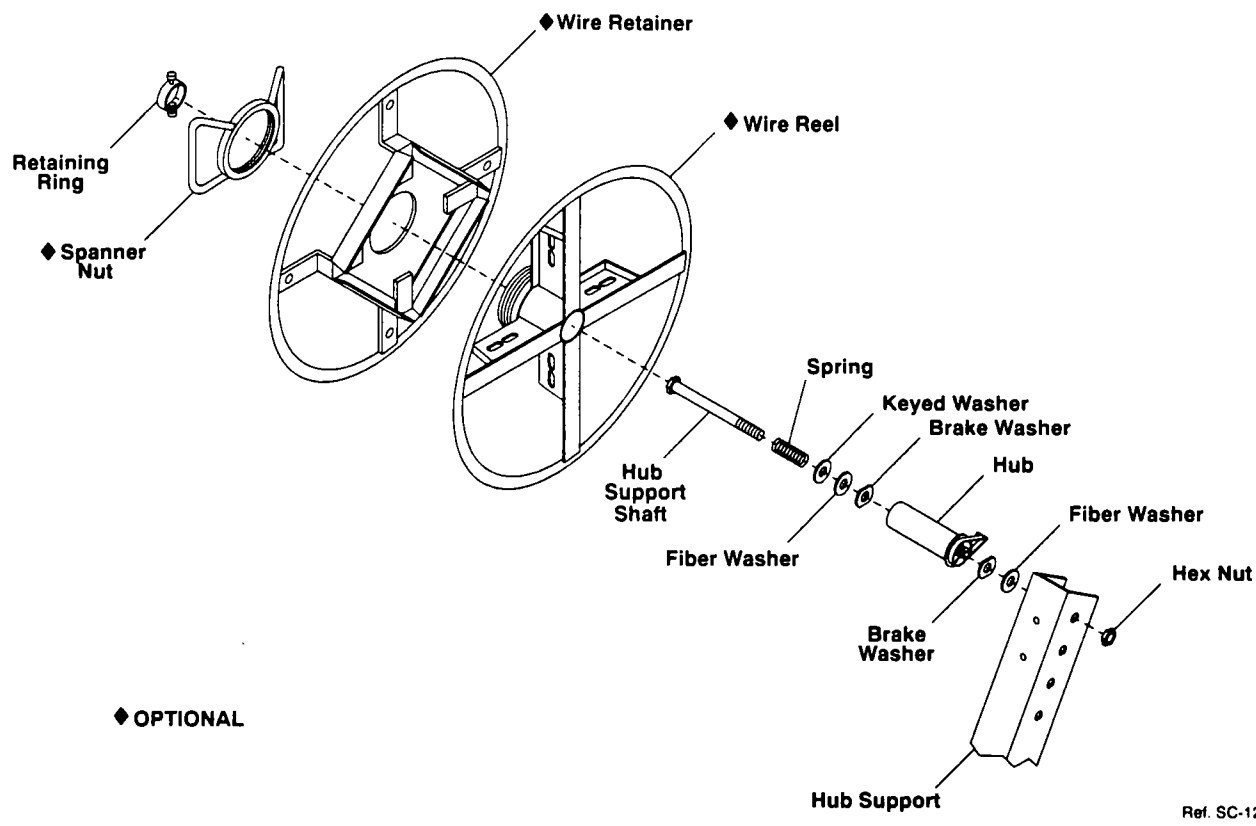

Ref. SC-127 328

Figure 6-1. Hub And Reel Assemblies

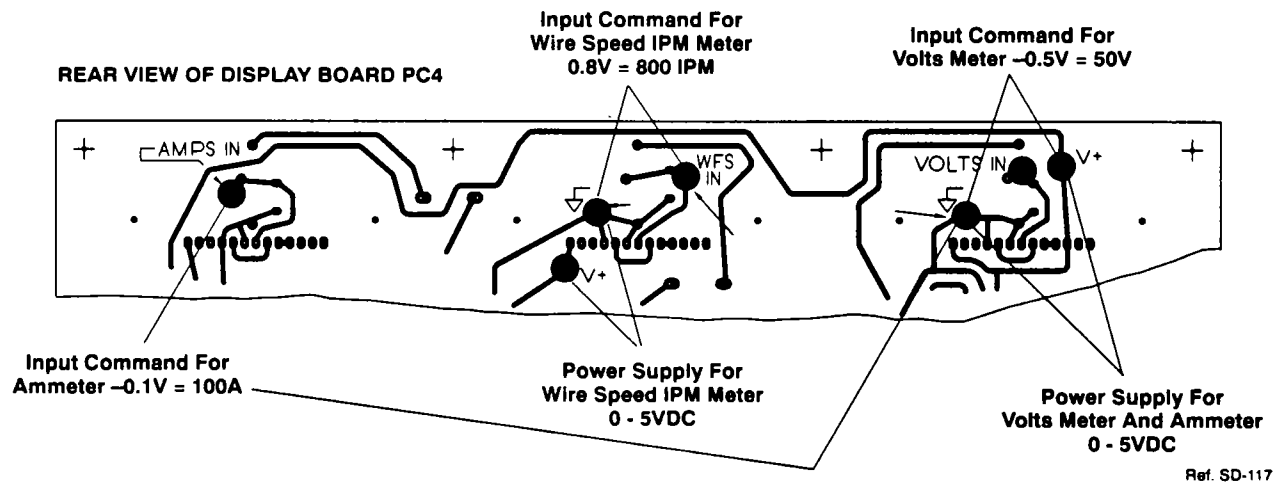

Ref. SD-117 838-B

Figure 6-2. Display Board Meter Checks

1. Open robot interface access door.
2. Locate display board PC4.
3. Check voltage according to Figure 6-2.
4. If a meter power supply and command voltage is correct and the meter is not working, replace the meter (see Section 6-5 and contact nearest Factory Authorized Service Station).
5. If the power supply or command voltage is incorrect, replace display board PC4 (see Section 6-5 and contact nearest Factory Authorized Service Station).

6-5. CIRCUIT BOARD HANDLING PRECAUTIONS



WARNING: ELECTRIC SHOCK can kill.

- Do not touch live electrical parts.
- Shut down unit, welding power source, and robot, and disconnect input power employing lockout/tagging procedures before inspecting, maintaining, or servicing.

Lockout/tagging procedures consist of padlocking line disconnect switch in open position, removing fuses from fuse box, or shutting off and red-tagging circuit breaker or other disconnecting device.



CAUTION: ELECTROSTATIC DISCHARGE (ESD) can damage circuit boards.

- *Put on properly grounded wrist strap BEFORE handling circuit boards.*
- *Transport circuit boards in proper static-shielding carriers or packages.*
- *Perform work only at a static-safe work area.*

INCORRECT INSTALLATION or misaligned plugs can damage circuit board.

- *Be sure that plugs are properly installed and aligned.*

EXCESSIVE PRESSURE can break circuit board.

- *Use only minimal pressure and gentle movement when disconnecting or connecting board plugs and removing or installing board.*

6-6. TROUBLESHOOTING



WARNING: ELECTRIC SHOCK can kill.

- *Do not touch live electrical parts.*
- *Shut down unit, welding power source, and robot, and disconnect input power employing lockout/tagging procedures before inspecting or servicing.*

Lockout/tagging procedures consist of padlocking line disconnect switch in open position, removing fuses from fuse box, or shutting off and red-tagging circuit breaker or other disconnecting device.

MOVING PARTS can cause serious injury.

- *Keep away from moving parts.*

HOT SURFACES can cause severe burns.

- *Allow cooling period before servicing.*

Troubleshooting to be performed only by qualified persons.

It is assumed that the unit was properly installed according to Section 3 of this manual, the operator is familiar with the function of controls, the robot interface was working properly, and that the trouble is not related to the welding process.

The following table is designed to diagnose and provide remedies for some of the troubles that may develop in this robot interface. Use this table in conjunction with the circuit diagram while performing troubleshooting procedures. If the trouble is not remedied after performing these procedures, contact the nearest Factory Authorized Service Station. In all cases of equipment malfunction, strictly follow the manufacturer's procedures and instructions.

Table 6-1. Troubleshooting

TROUBLE	PROBABLE CAUSE	REMEDY
No arc voltage control.	Output control connections.	Check and secure connections (see Section 3-4).
	Arc sensing connections.	Check and secure connections (see Section 3-4).
	Voltage Board PC1 not working.	Replace PC1 (see Section 6-5 and contact nearest Factory Authorized Service Station).
	Incorrect robot command voltage.	Check robot command voltage at Voltage Board PC1. Command voltage should be 0-10 vdc between sockets V (common) and U at RC17.
Wire speed (IPM) meter goes to zero.	Incorrect robot command voltage.	Check robot command voltage at Motor Board PC2. Signal should be 0-10 vdc between pins K and B (common) at RC5.
	Motor Board PC2 not working.	Replace PC2 (see Section 6-5 and contact nearest Factory Authorized Service Station).
Unit does not operate.	Fuse F1 Open.	Check F1, and replace if necessary (see Section 6-2). Correct overload problem before continuing operation.
	Circuit breaker CB1 tripped.	Check CB1, and reset if necessary (see Section 6-2). Correct overload problem before continuing operation.
No meter display.	Meter not working.	Use check points on Display Board PC4 to determine if power is available to meter (see Section 6-4). If check points are okay, replace meter (see Section 6-5 and contact nearest Factory Authorized Service Station).
	Display Board PC4 not working.	Use check points to determine if power is available (see Section 6-4). If check points do not test okay, replace PC4 (see Section 6-5 and contact nearest Factory Authorized Service Station).
No wire feed.	Robot signal.	Check input signal from robot to Motor Board PC2. Signal should be 0-10 vdc between pins K and B (common) on RC5.
	Relay CR1 not working.	Replace CR1.
	Motor Board PC2 not working.	Replace PC2 (see Section 6-5 and contact nearest Factory Authorized Service Station).
Wire feeds at maximum only.	Tach board at wire drive motor not working.	Replace tach board (see motor/drive assembly Owner's Manual).

6-7. USE OF INDICATOR LIGHTS FOR TROUBLESHOOTING

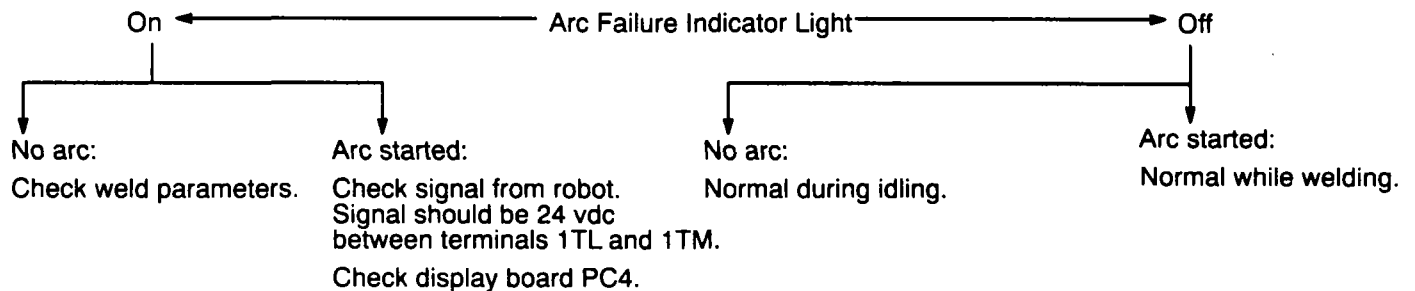
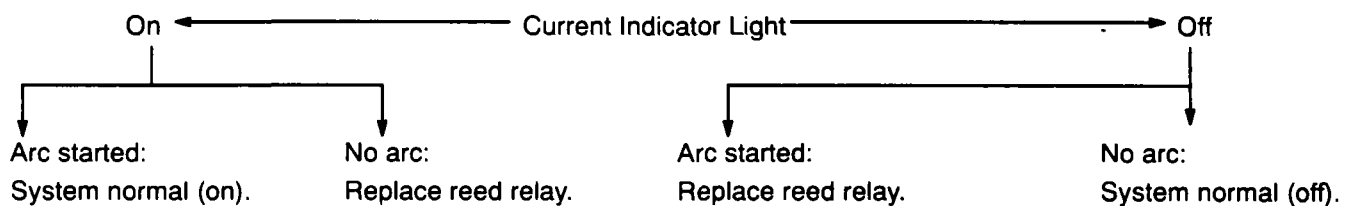
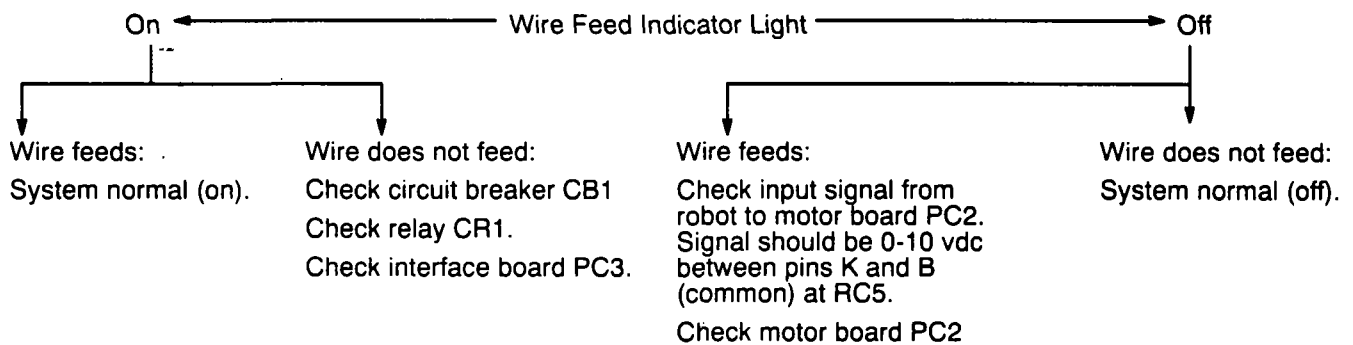
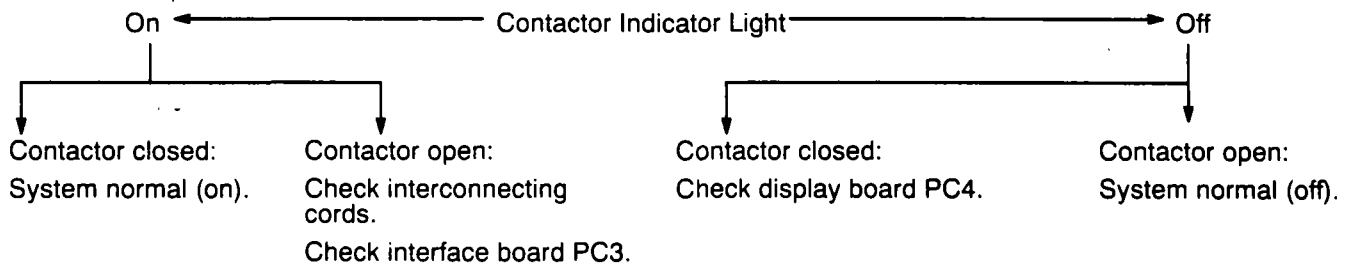
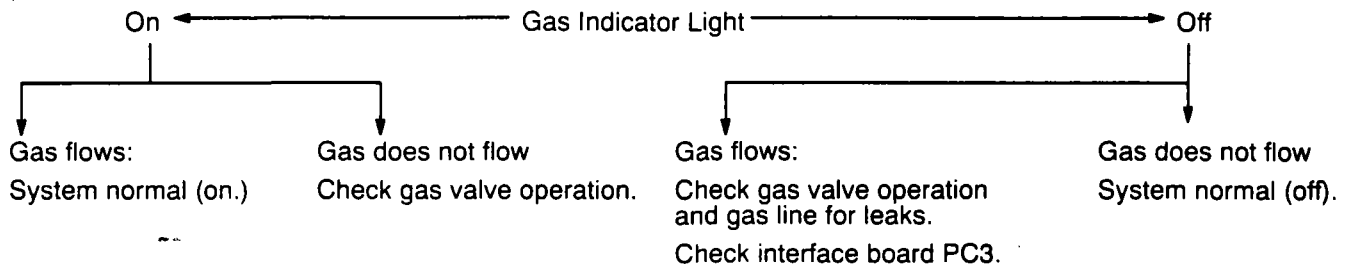

SECTION 7 - ELECTRICAL DIAGRAMS

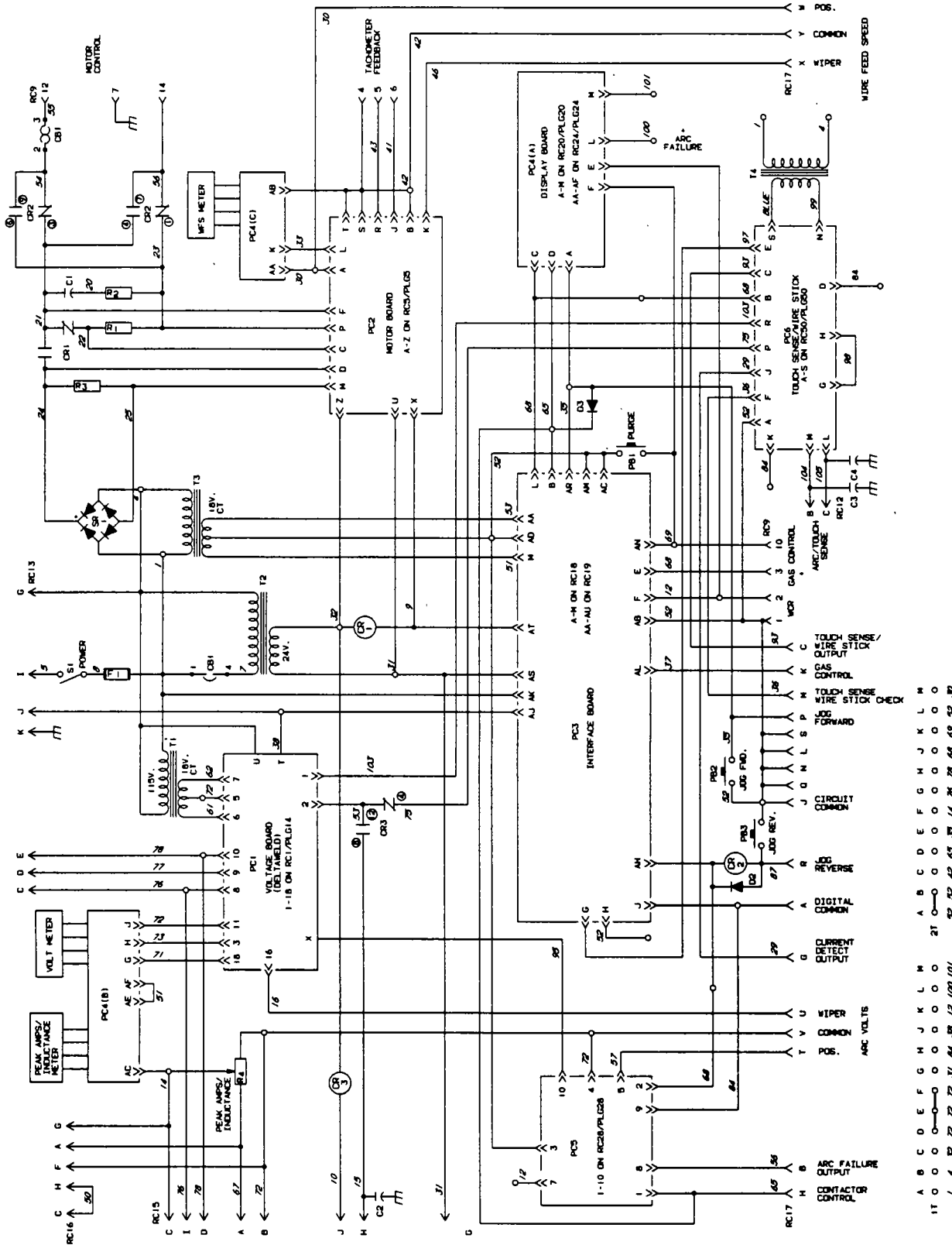

Circuit Diagram No. SC-139 000-A

Diagram 7-1. Circuit Diagram For Robot Interface

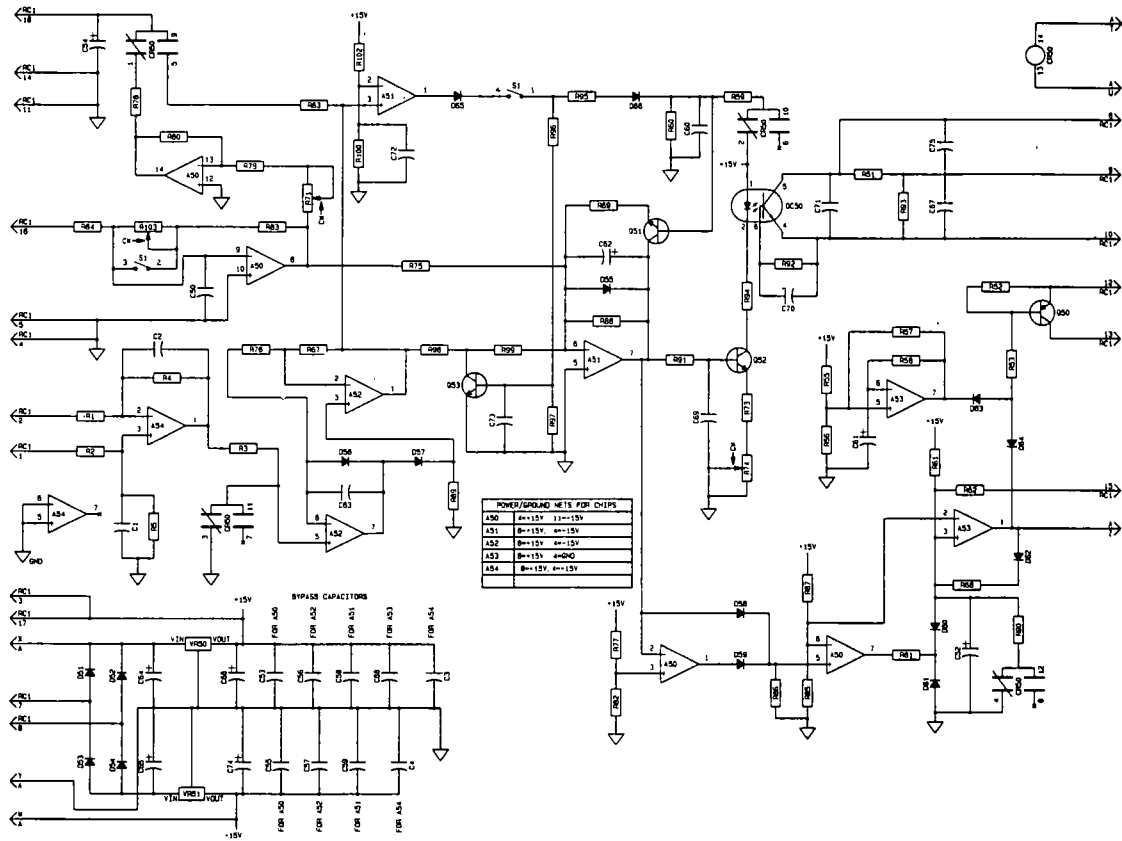

Circuit Diagram No. C-135 518

Diagram 7-2. Circuit Diagram For Voltage Board PC1

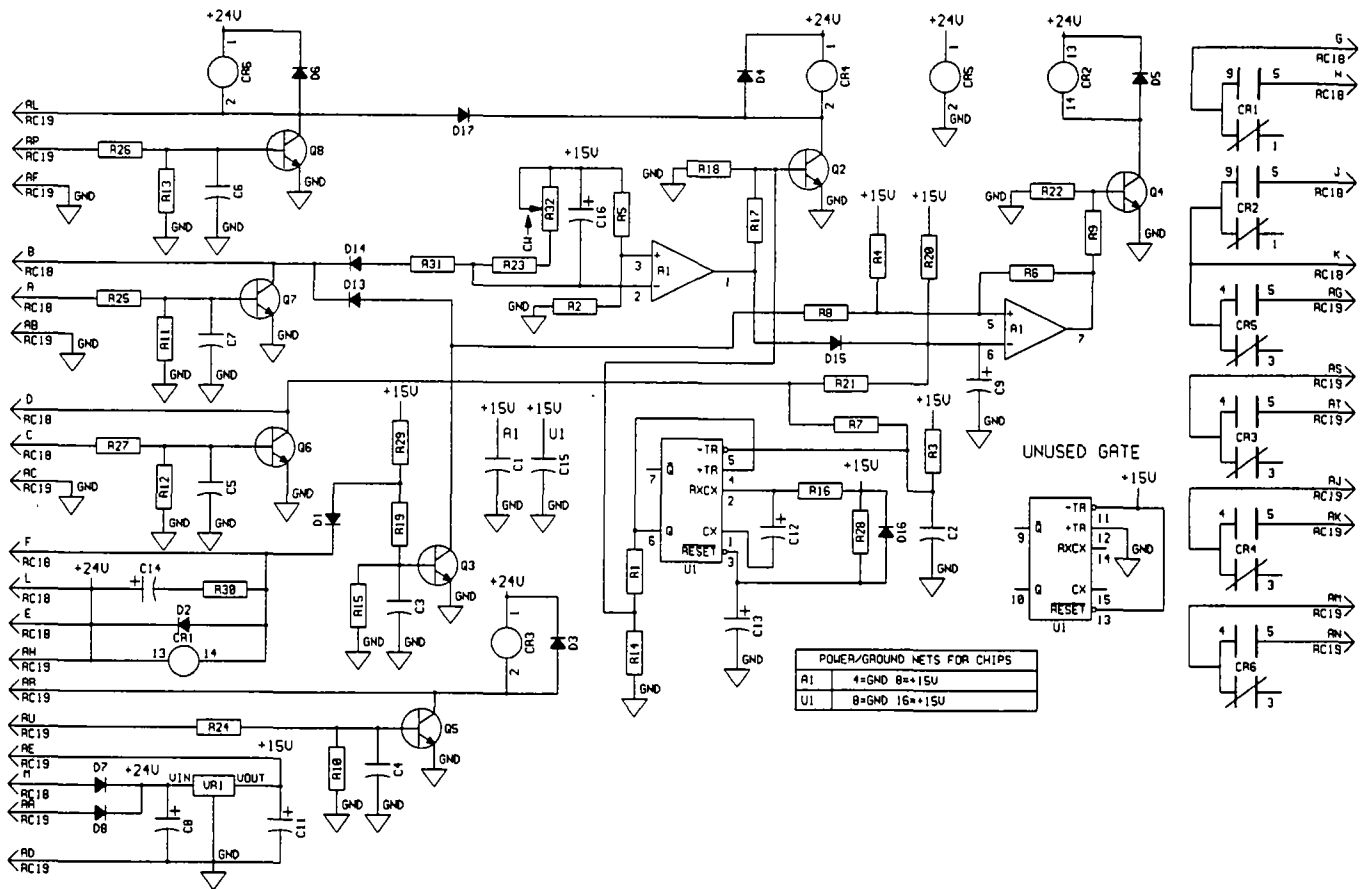

Circuit Diagram No. SB-141 311

Diagram 7-4. Circuit Diagram For Interface Board PC3

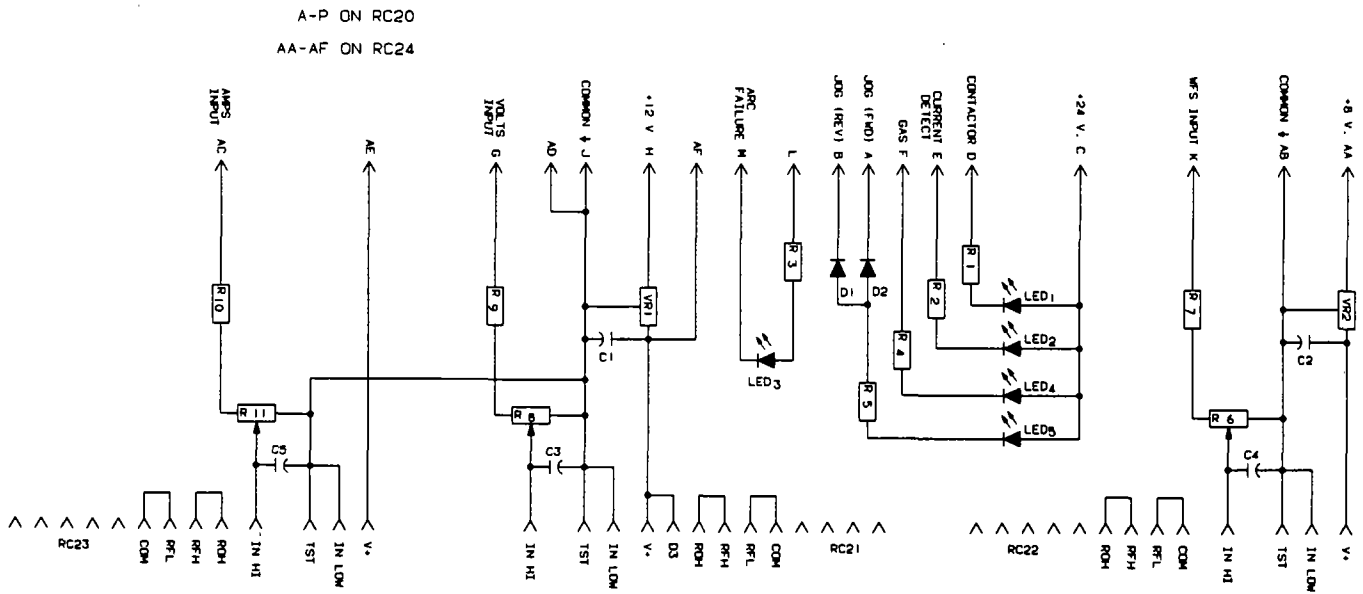

Circuit Diagram No. SB-111 341

Diagram 7-5. Circuit Diagram For Display Board PC4

SECTION 8 – PARTS LIST

Dia. Mkgs.	Part No.	Description	Quantity
Main Assembly			
C1	031 692	CAPACITOR, elctlt 750uf 200VDC	1
	006 426	CLAMP, capacitor 2.000dia	1
C2-4	028 291	CAPACITOR, cer disc .1uf 500VDC	3
CB1	011 991	CIRCUIT BREAKER, man reset 1P 1.5A 250V	1
CR1	109 006	RELAY, encl 24VAC DPDT	1
CR2	052 964	RELAY, encl 24VDC DPDT	1
CR3	095 033	RELAY, encl 24VAC 4PDT	1
	049 970	BRACKET, mtg relay	1
	079 844	SPRING, hold down relay	1
	027 811	SOCKET, relay 14 pin	1
	048 029	CLIP, retaining skt relay	1
D2,3	026 202	DIODE, rect 1A 400V SP	2
F1	*012 655	FUSE, minat cer 10A 250V	1
	046 432	HOLDER, fuse minat .250 x 1.250 panel mtg	1
PB1-3	021 105	SWITCH, PB SPDT	3
PC1	137 695	CIRCUIT CARD, voltage control (Fig 8-1)	1
	110 375	STAND-OFF SUPPORT, PC card No. 6 screw	8
	110 391	GUIDE, mtg-circuit card	3
PC2	071 642	CIRCUIT CARD, motor speed digital (Fig 8-2)	1
	083 147	GROMMET, scr No. 8/10	2
PC3	141 308	CIRCUIT CARD, interface (Fig 8-3)	1
PC4	117 836	CIRCUIT CARD, meter (Fig 8-4)	1
	089 032	LENS, LED 4341 red	5
	073 756	STAND-OFF, No. 6-32 x .625 lg	7
PC5	132 090	CIRCUIT CARD, interface (Fig 8-5)	1
PC6	140 021	CIRCUIT CARD, wire touch (Fig 8-6)	1
	109 041	CABLE, interconnecting (consisting of)	1
PLG9	047 636	· HOUSING PLUG & PINS, (consisting of)	1
	079 535	· TERMINAL, male 1 pin sz 16 18-14 wire	14
	079 739	· CLAMP, cable	2
	096 813	· CABLE, pwr shld 18ga 15/c (order by ft)	18ft
PLG16	048 598	· HOUSING PLUG & SOCKETS, (consisting of)	1
	079 534	· TERMINAL, female 1skt 14-18 wire	16
	049 989	CABLE, volt sensing (consisting of)	1
PLG12	073 686	· PLUG, 4skt 97-3106A-14S-2S	1
	039 828	· CLAMP, cable AN-3057-6	1
	600 848	· WIRE, lead mot 12ga strd (order by ft)	35ft
	604 109	· WIRE, lead 16ga strd (order by ft)	19ft
	601 226	· INSULATOR, vinyl clamp univ 25A	1
	601 228	· CLAMP, univ 25A	1
	600 750	· TERMINAL, ring tng .500 stud 16-14 wire	1
PLG 14,19	079 748	HOUSING, term header 18 pin	2
	079 747	TERMINAL, contact header 24-18 wire	18
	089 870	CABLE, interconnecting (consisting of)	1
PLG15	089 647	· PLUG, 10skt MS-3106A-18-1S	1
	073 332	· CLAMP, cable 97-3057-10	2
	073 140	· CABLE, port No. 18 10/c (order by ft)	10ft
	039 716	· PLUG, 10 pin MS-3106A-18-1P	1
PLG18	079 760	HOUSING, term header 12 pin	1
	079 747	TERMINAL, contact header 24-18	12
PLG20	081 379	HOUSING, term header 12 pin	1
	081 378	TERMINAL, female 1skt 22-18 wire	12
PLG24	084 198	HOUSING, term header 6 pin	1
	081 378	TERMINAL, female 1skt 22-18 wire	6

Dia. Mkgs.	Part No.	Description	Quantity
Main Assembly (Continued)			
PLG28	115 091	HOUSING PLUG & SOCKETS, (consisting of)	1
	113 746	· TERMINAL, female 1skt 24-18 wire	10
PLG50	092 159	HOUSING, term hdr 16 pin	1
	081 378	TERMINAL, female 1skt 22-18 wire	16
R1	030 651	RESISTOR, WW fxd 25W 10 ohm	1
	605 741	CLIP, mtg resistor .312 ID	4
R2	030 941	RESISTOR, WW fxd 100W 5 ohm	1
	030 949	HEAT SINK, rect	1
	010 199	TUBING, stl .275 ID x 1.000	2
	079 683	HEAT SINK, resistor	1
	056 170	SHIELD, resistor	1
	010 193	TUBING, stl .375 OD x .250	4
	057 084	BUSHING, snap-in nyl .250 ID x .375 mtg hole	1
R3	079 497	RESISTOR, WW fxd 25W 2K ohm	1
R4	603 856	POTENTIOMETER, WW stld sft 10/T 2W 10K ohm	1
	0937270007459	BRACKET, mtg pot	1
RC5	117 374	HOUSING, term conn 22posn	1
	009 335	STAND-OFF, No. 4-40 x .625 lg.	2
RC9	047 637	HOUSING RECEPTACLE & SOCKETS, (consisting of)	1
	079 534	· TERMINAL, female 1skt 14-18 wire	14
RC12	076 624	RECEPTACLE, 4 pin MS-3102A-14S-2P	1
RC13	109 768	RECEPTACLE, 14 pin 97-4102A-20-27P	1
RC15	089 646	RECEPTACLE, 10 pin MS-3102A-18-1P	1
RC16	097 867	RECEPTACLE, 17 pin MS-3102A-20-29P	1
RC17	1065360008908	RECEPTACLE	1
S1	011 609	SWITCH, tgl SPDT 15A 125VAC	1
SR1	035 704	RECTIFIER, integ 30A 600V	1
T1,3	035 759	TRANSFORMER, control mintr 115/36VCT	2
T2,4	036 135	TRANSFORMER, control 115/24VAC 50/60 Hz	2
	0923690008267	TUBING, stl .250 ID x 16ga wall x 1.937	2
1T,2T	038 783	BLOCK, term 20A 12P	2
	601 219	LINK, jumper term blk 20A	3
	010 916	CONNECTOR, clamp cable .750	1
	1324810008989	CABINET, control	1
	107 983	BLANK, snap-in nyl .500 mtg hole black	4
	112 473	PANEL, mtg components	1
+1169690008908		DOOR, access cabinet	1
	045 852	CLIP, component .687dia mtg adh back	2
	134 327	LABEL, warning general precautionary	1
	010 855	RETAINER, scr No. 2	2
	010 853	FASTENER, scr stld hd No. 2	2
	073 487	NUT, speed No. 2	2
		NAMEPLATE	1
	121 594	CABLE, interconnecting (consisting of)	1
	111 122	· HOUSING PLUG & PINS, (consisting of)	1
	109 770	· TERMINAL, male 1pin sz 45 16-22 wire	14
	116 964	· CLAMP, cable 97-3057-1012	2
	110 015	· CABLE, port No. 18 7/c (order by ft)	10ft
	111 123	· HOUSING PLUG & SOCKETS, (consisting of)	1
	109 771	· TERMINAL, female 1skt 16-22 wire sz 45	14
	071 006	CABLE, motor (consisting of)	1
	047 636	· HOUSING PLUG & PINS, (consisting of)	1
	079 535	· TERMINAL, male 1 pin sz 16 18-14 wire	14
	079 739	· CLAMP, cable strain relief sz 17	2
	073 139	· CABLE, port No. 16 6/c (order by ft)	10ft
	071 892	· RECEPTACLE w/SOCKETS, (consisting of)	1
	079 534	· TERMINAL, female 1skt 14-18 wire	14

Dia. Mkgs.	Part No.	Description	Quantity
Main Assembly (Continued)			
	048 144	· TERMINAL, male 1 pin plug keying	2
	1338640008989	· CABLE, interconnecting (consisting of)	1
	097 868	· PLUG, 17skt MS-3106A-20-29S	1
	116 964	· CLAMP, cable 97-3057-1012	2
	604 910	· CABLE, pwr shld 20ga 5/c (order by ft)	10ft
	097 866	· PLUG, 17 pin MS-3106A-20-29P	1
	056 462	· HOSE, gas (consisting of)	1
	604 550	· HOSE, nprn brd No. 1 x .187 ID (order by ft)	11ft
	010 606	· FITTING, hose brs nut .625-18RH	1
	056 108	· FITTING, hose brs ferrule .425 ID x .718 lg	1
	056 851	· FITTING, hose brs barbed nipple 3/16tg	1
	137 114	· CONTROL BOX, gas/current sensor (consisting of)	1
D1	026 202	· DIODE, rect 1A 400V SP	1
GS1	109 293	· VALVE, 24VDC 2 way 1/4 IPS port 1/8 orf	1
RC7	047 637	· HOUSING RECEPTACLE & SOCKETS, (consisting of)	1
	079 534	· TERMINAL, female 1skt 14-18 wire	14
RC16	090 246	· RECEPTACLE w/PINS, (consisting of)	1
	079 535	· TERMINAL, male 1 pin sz 16 18-14 wire	16
REED	135 130	· RELAY, current	1
5T	038 839	· BLOCK, term 20A 5P	1
	115 104	· CONNECTOR, clamp cable .500	1
	010 494	· BUSHING, snap-in nyl 1.375 ID x 1.750mtg hole	2
	057 358	· BUSHING, snap-in nyl 1.000 ID x 1.375mtg hole	2
	010 604	· FITTING, hose brs bushing 1/4NPT x .625-18RH	2
	602 934	· FITTING, pipe galv coupling .250NPSC	1
	079 573	· FITTING, pipe galv nipple L .250NPT x 6.000	1
	079 574	· BRACKET, mtg component	2
	137 121	· CASE SECTION, front/bottom/rear	1
	+079 682	· WRAPPER	1
	134 327	· LABEL, warning general precautionary	1
	072 094	· HUB & SPINDLE, (consisting of)	1
	058 428	· HUB, spool	1
	058 628	· WASHER, brake stl	2
	010 191	· WASHER, fbr .656 ID x 1.500 OD x .125thk	2
	135 205	· NUT, stl stlkg hex reg .625-11	1
	057 971	· WASHER, flat stl keyed 1.500dia x .125thk	1
	010 233	· SPRING, cprsn .970 OD x 1.250	1
	072 292	· SHAFT, spool support	1
	058 427	· RING, retaining spool	1
	092 989	· SUPPORT, spindle (consisting of)	1
	134 464	· LABEL, warning general precautionary	1

*Recommended Spare Parts.

+When ordering a component originally displaying a precautionary label, the label should also be ordered.
BE SURE TO PROVIDE MODEL AND SERIAL NUMBER WHEN ORDERING REPLACEMENT PARTS.

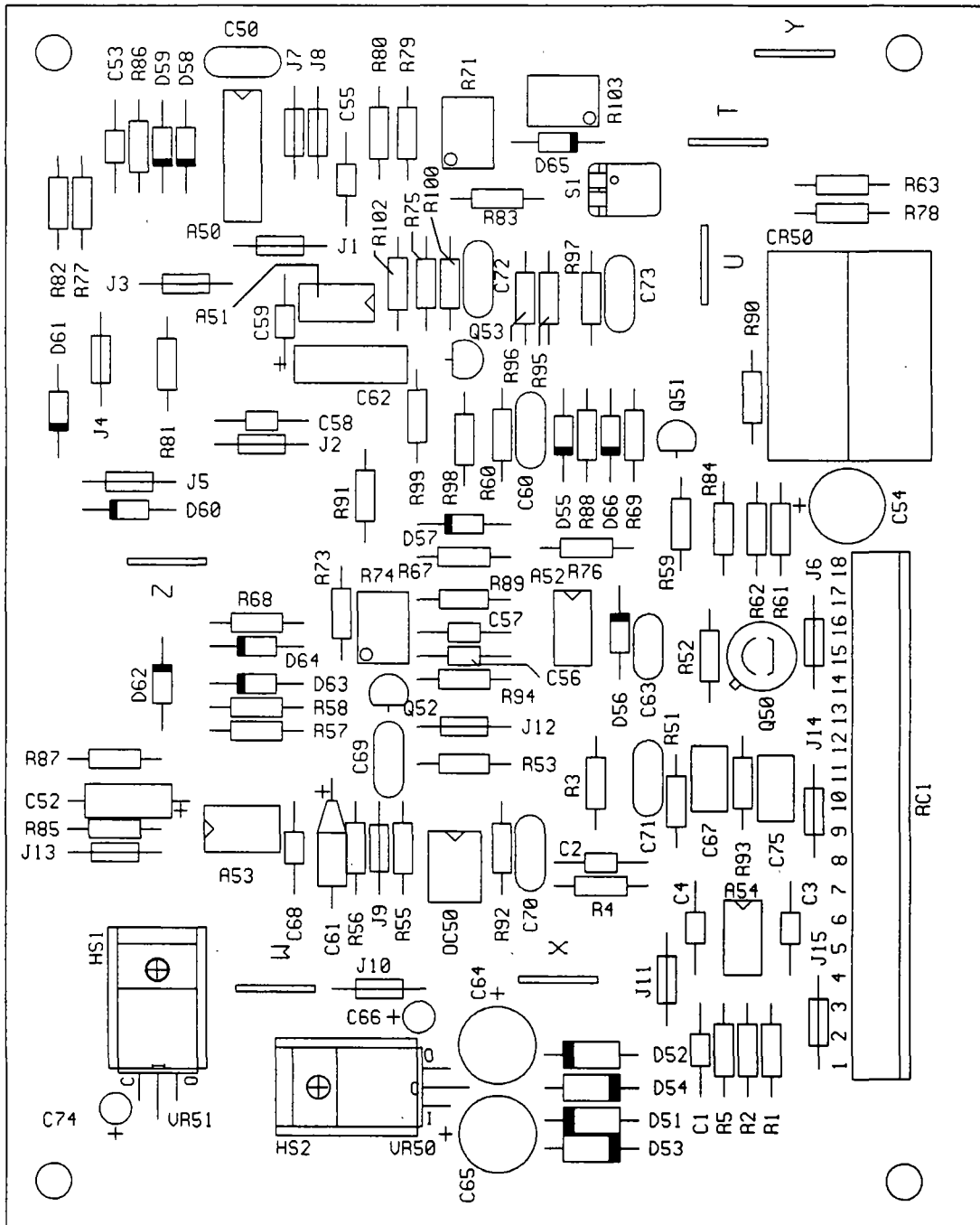
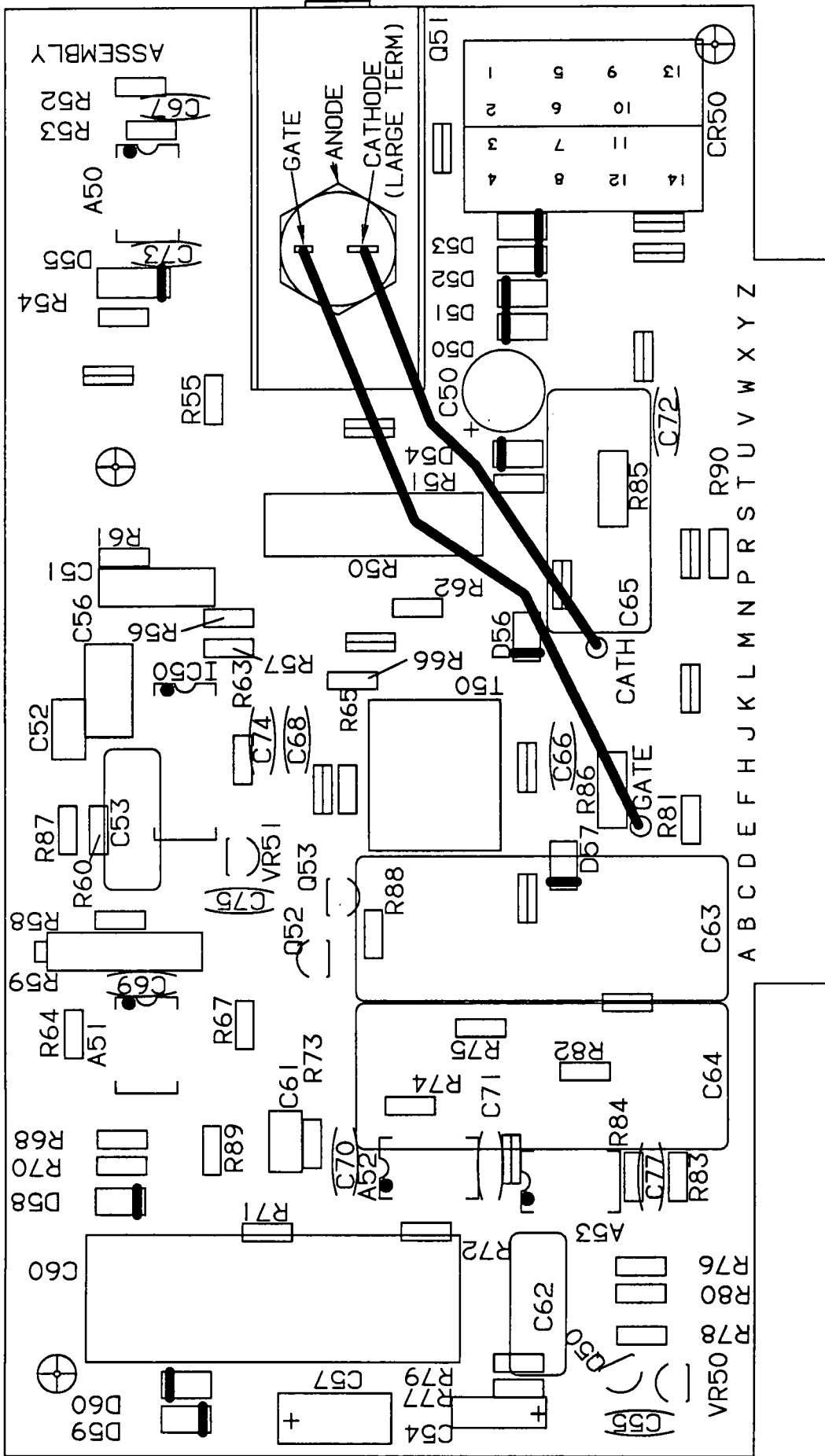

Figure 8-1. Circuit Card, Voltage Control PC1

Dia. Mkgs.	Part No.	Description	Quantity
PC1	137 695	Figure 8-1. Circuit Card, Voltage Control	
A50	096 275	IC, linear 324	1
A51,52,54	114 176	IC, linear 353	3
A53	009 159	IC, linear 358	1
C1-4,53, 55-59,68 C50,60, 69-73	122 723	CAPACITOR, cer mono .1uf 50VDC	11
C52	000 340	CAPACITOR, cer disc .01uf 50VDC	7
C54	031 677	CAPACITOR, tantlm 5.6uf 35VDC	1
C61	000 861	CAPACITOR, elctlt 33uf 35V	1
C62	005 023	CAPACITOR, tantlm 2.2uf 20V	1
C63	009 577	CAPACITOR, tantlm 27uf 35V	1
C64,65	053 992	CAPACITOR, cer disc .001uf 1000VDC	1
C66,74	118 460	CAPACITOR, elctlt 330uf 50VDC	2
C67,75	000 348	CAPACITOR, tantlm .47uf 35V	2
CR50	121 684	CAPACITOR, polye met film .47uf 100V	2
	093 558	RELAY, encl 120VAC 4PDT	1
	091 861	SOCKET, relay 14skt	1
	079 844	SPRING, hold down relay	1
D51-54	026 202	DIODE, rect 1A 400V SP	4
D55-66	028 351	DIODE, sig .020A 75V SP	12
J1-15	092 648	RESISTOR, WW fxd zero ohm	15
OC50	047 034	IC, interface 4N26	1
Q50	035 842	TRANSISTOR, PNP .6A 40V	1
Q51-53	037 200	TRANSISTOR, NPN 200MA 40V	3
R1,2	089 174	RESISTOR, MF .25W 100K ohm	2
R3	089 176	RESISTOR, MF .25W 20K ohm	1
R4,5,67,76	089 175	RESISTOR, MF .25W 10K ohm	4
R51,80,86,87	039 331	RESISTOR, CF .25W 4.7K ohm	4
R52,91	035 888	RESISTOR, CF .25W 2.2K ohm	2
R53,73	078 431	RESISTOR, C .25W 330 ohm	2
R55-57,85	035 827	RESISTOR, CF .25W 10K ohm	4
R58,61	039 336	RESISTOR, CF .25W 220K ohm	2
R59,60,95-97	035 826	RESISTOR, CF .25W 6.8K ohm	5
R62,68,82	035 825	RESISTOR, CF .25W 1K ohm	3
R63,78	097 110	RESISTOR, MF .25W 1K ohm	2
R69	108 437	RESISTOR, MF .25W 4.75K ohm	1
R71	000 038	POTENTIOMETER, cermet trmr 25/T .5W 2K ohm	1
R74,103	009 173	POTENTIOMETER, cermet trmr 20/T .5W 5K ohm	2
R75,89	052 137	RESISTOR, MF .25W 5.11K ohm	2
R77	039 333	RESISTOR, CF .25W 18K ohm	1
R79	039 330	RESISTOR, CF .25W 3.9K ohm	1
R81	035 886	RESISTOR, CF .25W 22K ohm	1
R83	084 205	RESISTOR, MF .25W 3.32K ohm	1
R84	000 885	RESISTOR, MF .25W 10K ohm	1
R88,92	081 833	RESISTOR, CF .25W 2.7 meg ohm	2
R90	035 885	RESISTOR, CF .25W 68K ohm	1
R93	091 799	RESISTOR, MF .25W 8.25K ohm	1
R94	035 823	RESISTOR, CF .25W 100 ohm	1
R98	039 329	RESISTOR, CF .25W 2.7K ohm	1
R99	108 433	RESISTOR, MF .25W 2.43K ohm	1
R100	117 134	RESISTOR, MF .25W 24.3K ohm	1
R102	121 714	RESISTOR, MF .25W 51.1K ohm	1
RC1	079 749	TERMINAL, header 18 pin	1
S1	092 367	SWITCH, dip SPST 2posn	1
VR50	083 772	IC, linear 7815	1
VR51	046 932	IC, linear 7915	1

BE SURE TO PROVIDE MODEL AND SERIAL NUMBER WHEN ORDERING REPLACEMENT PARTS.



SC-093 390-E

Figure 8-2. Circuit Card, Motor Speed Digital PC2

Dia. Mkgs.	Part No.	Description	Quantity
PC2	071 642	Figure 8-2. Circuit Card, Motor Speed Digital	
A50-53	009 159	IC, linear 358	4
C50	039 482	CAPACITOR, elctlt 100uf 35VDC	1
C51	031 699	CAPACITOR, mylar .0022uf 200VDC	1
C52,61	073 739	CAPACITOR, cer .1uf 50VDC	2
C53,62	035 833	CAPACITOR, mylar .033uf 100VDC	2
C54	005 023	CAPACITOR, tantlm 2.2uf 20V	1
C55,66-75,77	031 643	CAPACITOR, cer .01uf 500VDC	12
C56	073 549	CAPACITOR, mylar .015uf 200V	1
C57	007 742	CAPACITOR, elctlt 10uf 35V	1
C60	035 561	CAPACITOR, mylar 4uf 200V	1
C63,64	044 602	CAPACITOR, polye film .47uf 400VDC	2
C65	031 721	CAPACITOR, mylar .22uf 200VDC	1
CR50	095 033	RELAY, encl 24VAC 4PDT	1
	091 861	SOCKET, relay	1
	079 844	SPRING, hold down-relay	1
D50-54,56-60	026 202	DIODE, 1A 400V SP	10
D55	080 910	DIODE, zener 15V 5W	1
IC50	081 800	IC, interface 2907	1
Q50,53	037 200	TRANSISTOR, NPN 200MA 40V	2
Q51	037 824	THYRISTOR, SCR 7.4A 200V	1
Q52	039 355	TRANSISTOR, UJT 15MA 40V	1
R50	030 839	RESISTOR, WW fxd 5W 220 ohm	1
Note 1	035 827	RESISTOR, CF .25W 10K ohm	10
R52,56,61	052 138	RESISTOR, CF .25W 20K ohm	3
R53	039 332	RESISTOR, CF .25W 15K ohm	1
R58,62,65,66			
71,72,76,90	035 884	RESISTOR, CF .25W 100K ohm	8
R59	030 007	POTENTIOMETER, cermet 15/T .75W 50K ohm	1
R60,87,88	039 335	RESISTOR, CF .25W 47K ohm	3
R63,79	039 106	RESISTOR, CF .25W 470 ohm	2
R64	039 331	RESISTOR, CF .25W 4.7K ohm	1
R70	049 015	RESISTOR, CF .25W 10meg ohm	1
R73,83	039 328	RESISTOR, CF .25W 1.5K ohm	2
R77	052 142	RESISTOR, CF .25W 120K ohm	1
R78	039 108	RESISTOR, CF .25W 82K ohm	1
R80	035 886	RESISTOR, CF .25W 22K ohm	1
R81,84	035 825	RESISTOR, CF .25W 1K ohm	2
R85	030 937	RESISTOR, CF .5W 10 ohm	1
R86	030 090	RESISTOR, CF .5W 47 ohm	1
	092 648	RESISTOR, WW fxd zero ohm	15
T50	085 399	TRANSFORMER, pulse	1
VR1	047 272	IC, linear 78L12	1
VR50	081 799	IC, linear 78L08	1

Note: R51,54,55,57,67,68,74,75,82,89

BE SURE TO PROVIDE MODEL AND SERIAL NUMBER WHEN ORDERING REPLACEMENT PARTS.

Dia. Mkgs.	Part No.	Description	Quantity
PC3	141 308	Figure 8-3. Circuit Card, Interface	
A1	009 159	IC, linear 358	1
C1-7,15	122 723	CAPACITOR, cer mono .1uf 50VDC	8
C8	083 973	CAPACITOR, elctlt 1000uf 35VDC	1
C9	031 677	CAPACITOR, tantlm 5.6uf 35VDC	1
C11,12	000 348	CAPACITOR, tantlm .47uf 35V	2
C13	072 130	CAPACITOR, tantlm 1uf 35VDC	1
C14	000 859	CAPACITOR, elctlt 220uf 35VDC	1
C16	073 714	CAPACITOR, tantlm .22uf 35V	1
CR1,2	095 521	RELAY, encl 24VDC 4PDT	2
CR3-6	099 018	RELAY, encl 24VDC SPDT	4
	079 844	SPRING, hold down relay	2
	091 861	SOCKET, relay	2
D1,13-17	028 351	DIODE, sig .020A 75V	6
D2-8	026 202	DIODE, rect 1A 400V	7
J1-10	092 648	RESISTOR, WW fxd zero ohm	10
Q2-8	037 200	TRANSISTOR, NPN 200MA 40V	7
R1,4,8,9	035 826	RESISTOR, CF .25W 6.8K ohm	4
R2	039 332	RESISTOR, CF .25W 15K ohm	1
R3,5,6	035 827	RESISTOR, CF .25W 10K ohm	3
R7,31	035 825	RESISTOR, CF .25W 1K ohm	2
R10-14,17-22,29	039 331	RESISTOR, CF .25W 4.7K ohm	12
R15,23	039 329	RESISTOR, CF .25W 2.7K ohm	2
R16	039 336	RESISTOR, CF .25W 220K ohm	1
R24-27	053 572	RESISTOR, MF .25W 12.1K ohm	4
R28	035 884	RESISTOR, CF .25W 100K ohm	1
R30	035 823	RESISTOR, CF .25W 100 ohm	1
R32	052 152	POTENTIOMETER, cermet trmr 25/T .5W 1 meg ohm	1
RC18	079 759	TERMINAL, hdr 12 pin	1
RC19	079 749	TERMINAL, hdr 18 pin	1
U1	094 594	IC, digital 4098	1
VR1	081 832	IC, linear 78M15	1

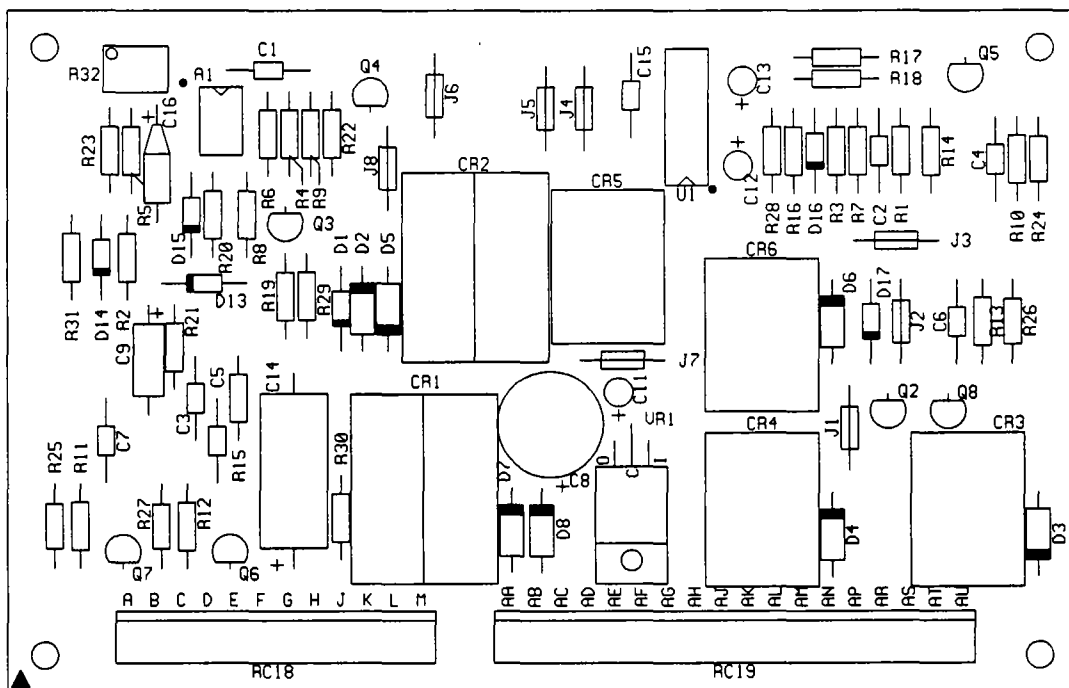
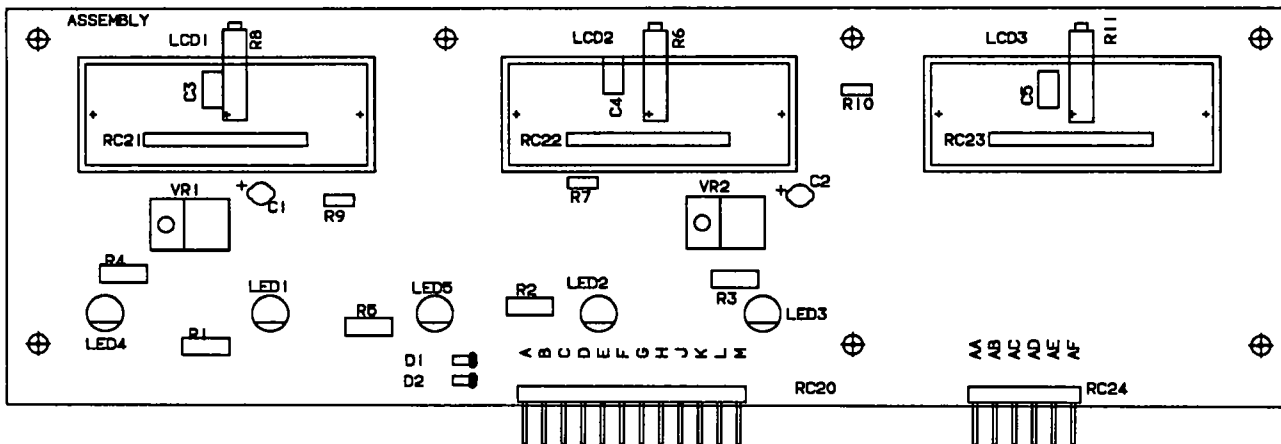

Figure 8-3. Circuit Card, Interface PC3

SA-141 309

BE SURE TO PROVIDE MODEL AND SERIAL NUMBER WHEN ORDERING REPLACEMENT PARTS.

Dia. Mkgs.	Part No.	Description	Quantity
PC4	117 836	Figure 8-4. Circuit Card, Meter	
C1,2	000 348	CAPACITOR, tantlm .47uf 35V	2
C3-5	073 739	CAPACITOR, cer .1uf 50VDC	3
D1,2	028 351	DIODE, sig .020A 75V SP	2
LCD1-3	108 453	METER, digital	3
LED1,2,4,5	089 028	LED, 5330A1040MCD	4
LED3	097 763	LED, 5330A19200MCD	1
R1-5	030 028	RESISTOR, .5W 1.5K ohm	5
R6,8,11	030 140	POTENTIOMETER, cer 15/T .75W 200K ohm	3
R7,9,10	003 272	RESISTOR, CF .25W 1meg ohm	3
RC20	081 381	TERMINAL, header 12 pin	1
RC21-23	109 161	TERMINAL, header 13skt	3
RC24	084 194	TERMINAL, header 6 pin	1
VR1,2	071 248	IC, linear 78M05	2
	070 026	STAND-OFF, No. 6-32 x .437	6



Ref. SD-117 838-B

Figure 8-4. Circuit Card, Meter PC4

BE SURE TO PROVIDE MODEL AND SERIAL NUMBER WHEN ORDERING REPLACEMENT PARTS.

Dia. Mkgs.	Part No.	Description	Quantity
PC5	132 090	Figure 8-5. Circuit Card, Interface	
A1	009 159	IC, linear 358	1
C1	039 482	CAPACITOR, elctlt 100uf 35VDC	1
C2	000 348	CAPACITOR, tantlm .47uf 35V	1
C3	031 677	CAPACITOR, tantlm 5.6uf 35VDC	1
C4	122 723	CAPACITOR, cer mono .1uf 50VDC	1
CR1,2	099 018	RELAY, encl 24VDC SPDT	2
D1,4	026 202	DIODE, rect 1A 400V SP	2
D2,3	028 351	DIODE, sig .020A 75V SP	2
J1	092 648	RESISTOR, WW fxd zero ohm	1
Q1	037 200	TRANSISTOR, NPN 200MA 40V	1
R1	035 824	RESISTOR, CF .25W 270 ohm	1
R2	009 173	POTENTIOMETER, cermet trmr 20/T .5W 5K ohm	1
R3	035 825	RESISTOR, CF .25W 1K ohm	1
R4	038 584	RESISTOR, CF .25W 470K ohm	1
R5,7	035 827	RESISTOR, CF .25W 10K ohm	2
R6	039 332	RESISTOR, CF .25W 15K ohm	1
R8	035 826	RESISTOR, CF .25W 6.8K ohm	1
R9	039 331	RESISTOR, CF .25W 4.7K ohm	1
RC1	113 747	TERMINAL, header 10 pin	1
VR1	095 269	IC, linear 317T	1

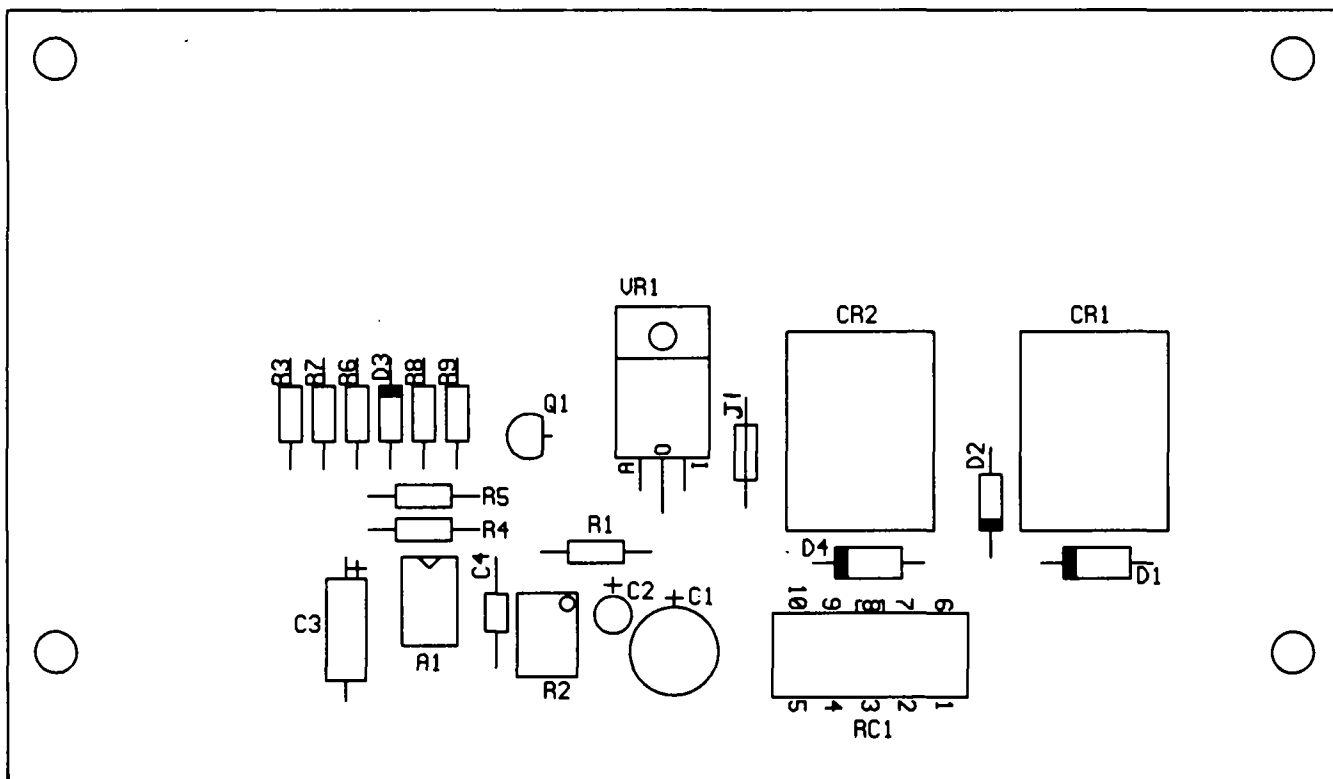

A-132 089-A

Figure 8-5. Circuit Card, Interface PC5

BE SURE TO PROVIDE MODEL AND SERIAL NUMBER WHEN ORDERING REPLACEMENT PARTS.

Dia. Mkgs.	Part No.	Description	Quantity
PC6	140 021	Figure 8-6. Circuit Card, Wire Touch	
A1	009 159	IC, linear 358	1
C1	090 573	CAPACITOR, elctlt 10uf 50V	1
C2	000 348	CAPACITOR, tantlm .47uf 35V	1
C3	039 482	CAPACITOR, elctlt 100uf 35VDC	1
C4	122 723	CAPACITOR, cer mono .1uf 50VDC	1
CR1-3	004 855	RELAY, encl 24VDC 4PDT	3
D1-3,5-8	026 202	DIODE, rect 1A 400V	7
D9	037 449	DIODE, zener 15V 1W	1
J1,2	092 648	RESISTOR, WW fxd zero ohm	2
Q1,2	037 200	TRANSISTOR, NPN 200MA 40V	2
R1,5,7	035 827	RESISTOR, CF .25W 10K ohm	3
R2,3	035 826	RESISTOR, CF .25W 6.8K ohm	2
R4	039 331	RESISTOR, CF .25W 4.7K ohm	1
R6,8	035 888	RESISTOR, CF .25W 2.2K ohm	2
R9,10	030 710	RESISTOR, C 1W 270 ohm	2
RC50	092 160	TERMINAL, hdr 16 pin	1
VR1	083 772	IC, linear 7815	1

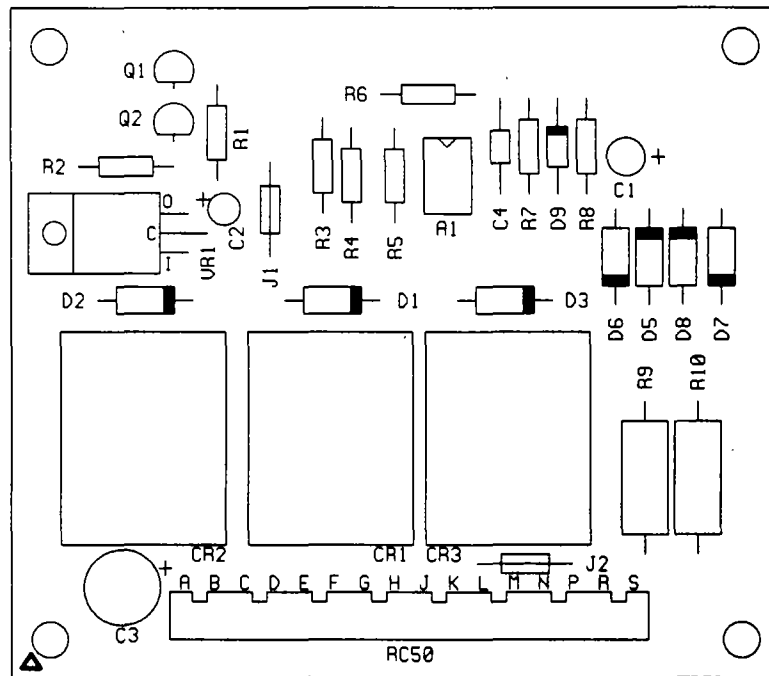

SA-140 020

Figure 8-6. Circuit Card, Wire Touch PC6

BE SURE TO PROVIDE MODEL AND SERIAL NUMBER WHEN ORDERING REPLACEMENT PARTS.

