

## MODELS: 7980-( )-( ) 85,000 R.P.M. TURBINE GRINDER

### NOTICE

ARO is not responsible for customer modification of tools for applications on which ARO was not consulted.

### ⚠ WARNING

**IMPORTANT SAFETY INFORMATION ENCLOSED.  
READ THIS MANUAL BEFORE OPERATING TOOL.**

**IT IS THE RESPONSIBILITY OF THE EMPLOYER TO PLACE THE INFORMATION  
IN THIS MANUAL INTO THE HANDS OF THE OPERATOR.**

**FAILURE TO OBSERVE THE FOLLOWING WARNINGS COULD RESULT IN INJURY.**

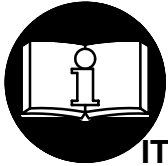

#### PLACING TOOL IN SERVICE

- Always operate, inspect and maintain this tool in accordance with American National Standards Institute Safety Code for Portable Air Tools (ANSI B186.1).
- For safety, top performance, and maximum durability of parts, operate this tool at 90 psig (6.2 bar/620 kPa) maximum air pressure at the inlet with 3/16" (5 mm) inside diameter air supply hose.
- Always turn off the air supply and disconnect the air supply hose before installing, removing or adjusting any accessory on this tool, or before performing any maintenance on this tool.
- Do not use damaged, frayed or deteriorated air hoses and fittings.
- Be sure all hoses and fittings are the correct size and are tightly secured. See Dwg. TPD905-1 for a typical piping arrangement.
- Always use clean, dry air at 90 (6.2 bar/ 620 kPa) psig maximum air pressure. Dust, corrosive fumes and/or excessive moisture can ruin the motor of an air tool.
- Do not lubricate tools with flammable or volatile liquids such as kerosene, diesel or jet fuel.
- Do not remove any labels. Replace any damaged label.

#### USING THE TOOL

- Always wear eye protection when operating or performing maintenance on this tool.
- Always wear hearing protection when operating this tool.
- Keep hands, loose clothing and long hair away from rotating end of tool.
- Anticipate and be alert for sudden changes in motion during start up and operation of any power tool.
- Keep body stance balanced and firm. Do not overreach when operating this tool. High reaction torques can occur at or below the recommended air pressure.
- Tool accessories may continue to rotate briefly after throttle is released.
- Air powered tools can vibrate in use. Vibration, repetitive motions or uncomfortable positions may be harmful to your hands and arms. Stop using any tool if discomfort, tingling feeling or pain occurs. Seek medical advice before resuming use.
- Use accessories recommended by ARO.
- This tool is not designed for working in explosive atmospheres.
- This tool is not insulated against electric shock.

### NOTICE

The use of other than genuine ARO replacement parts may result in safety hazards, decreased tool performance, and increased maintenance, and may invalidate all warranties.

Repairs should be made only by authorized trained personnel. Consult your nearest ARO Authorized Servicenter.

For parts and service information, contact your local ARO distributor, or the Customer Service Dept. of the Ingersoll-Rand Distribution Center, White House, TN at PH: (615) 672-0321, FAX: (615) 672-0801.

#### ARO Tool Products

**Ingersoll-Rand Company**

1725 U.S. No. 1 North • P.O. Box 8000 • Southern Pines, NC 28388-8000

©2000 INGERSOLL-RAND COMPANY • PRINTED IN U.S.A.

## WARNING LABEL IDENTIFICATION

### ▲ WARNING

FAILURE TO OBSERVE THE FOLLOWING WARNINGS COULD RESULT IN INJURY.

	<p><b>▲ WARNING</b></p> <p>Always wear eye protection when operating or performing maintenance on this tool.</p>
---	--

	<p><b>▲ WARNING</b></p> <p>Always wear hearing protection when operating this tool.</p>
---	---

	<p><b>▲ WARNING</b></p> <p>Always turn off the air supply and disconnect the air supply hose before installing, removing or adjusting any accessory on this tool, or before performing any maintenance on this tool.</p>
--	--



	<p><b>▲ WARNING</b></p> <p>Air powered tools can vibrate in use. Vibration, repetitive motions or uncomfortable positions may be harmful to your hands and arms. Stop using any tool if discomfort, tingling feeling or pain occurs. Seek medical advice before resuming use.</p>
--	---

	<p><b>▲ WARNING</b></p> <p>Do not carry the tool by the hose.</p>
---	---

	<p><b>▲ WARNING</b></p> <p>Do not use damaged, frayed or deteriorated air hoses and fittings.</p>
--	---

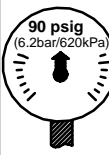
	<p><b>▲ WARNING</b></p> <p>Keep body stance balanced and firm. Do not overreach when operating this tool.</p>
---	---

	<p><b>▲ WARNING</b></p> <p>Operate at 90 psig (6.2 bar/ 620 kPa) Maximum air pressure.</p>
---	--

<b>▲ WARNING</b>	
<p><b>▲ WARNING</b></p> <p>Read the manual before operating this tool. Operate at 90 psig/6.2 bar max.</p>	  
PN 48176-1 LABEL (NON-EU MODELS)	PN 49883 LABEL (-EU MODELS)
<p>This label must appear on the tool at all times. If it is lost or damaged, a replacement label is available at no cost.</p>	

## GRINDER SPECIFIC WARNINGS

- Do not use this tool if actual free speed exceeds the nameplate rpm.
- Before mounting a wheel, after any tool repair or whenever a Grinder is issued for use, check free speed of Grinder with a tachometer to make certain its actual speed at 90 psig (6.2 bar/620 kPa) does not exceed rpm stamped or printed on the nameplate. Grinders in use on the job must be similarly checked at least once each shift.
- Always use the recommended ARO Wheel Guard furnished with the Grinder.
- Do not use any grinding wheel, bur or other accessory having a maximum operating speed less than the free speed of the Grinder in which it is being used. Always conform to maximum rpm on grinding wheel blotters.
- Inspect all grinding wheels for chips or cracks prior to mounting. Do not use a wheel that is chipped or cracked or otherwise damaged. Do not use a wheel that has been soaked in water or any other liquid.
- Make certain grinding wheel properly fits the arbor. Do not use reducing bushings to adapt a wheel to any arbor unless such bushings are supplied by and recommended by the wheel manufacturer.
- After mounting a new wheel, hold the Grinder under a steel workbench or inside a casting and run it for at least 60 seconds. Make certain no one is within the operating plane of the grinding wheel. If a wheel is defective, improperly mounted or the wrong size and speed, this is the time it will usually fail.
- When starting with a cold wheel, apply it to the work slowly until the wheel gradually warms up. Make smooth contact with the work and avoid any bumping action or excessive pressure.
- Always replace a damaged, bent or severely worn wheel guard. Do not use a wheel guard that has been subjected to a wheel failure.
- Make certain wheel flanges are at least 1/3 the diameter of grinding wheel, free of nicks, burrs and sharp edges. Always use wheel flanges furnished by the manufacturer; never use a makeshift flange or a plain washer. Tighten Flange Nut securely.
- Guard opening must face away from operator. Bottom of wheel must not project beyond guard.
- Always use a wheel blotter between each wheel flange and the wheel. The blotters must be at least as large in diameter as the wheel flanges.
- Do not attempt to disassemble the Controller. The Controller is available only as a unit and is guaranteed for the life of the tool if it is not abused.
- Before installing a new Cylinder Case Assembly, always select the correct Assembly for the motor package you are using.

## LUBRICATION



<u>Where Used</u>	<u>ARO Part #</u>	<u>Description</u>
"O" Rings	36460	4 oz. Stringy Lubricant
Bearings	33153	5 lb. "EP" – NLGI #1 Grease

Always use an air line lubricator with these tools.

We recommend the following Filter–Lubricator–Regulator Unit:

### ARO Model P29231–110

Lack of or an excessive amount of lubrication will affect the performance and life of this tool. Use only recommended lubricants.

## CAUTION

Do not mark any nonmetallic surface on this tool with customer identification codes. Such actions could affect tool performance.

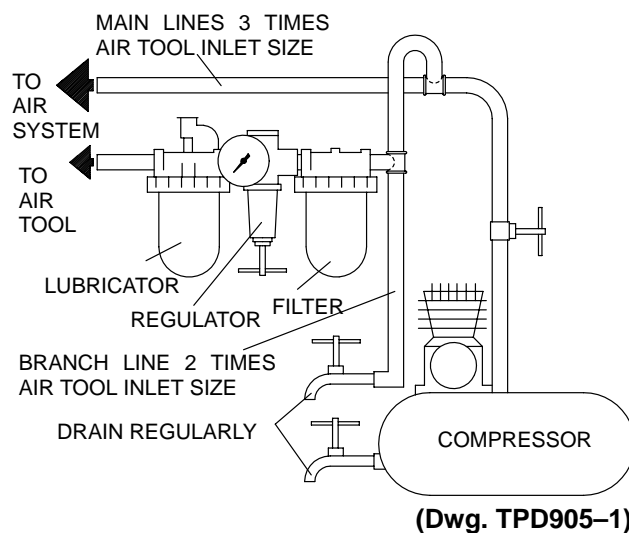

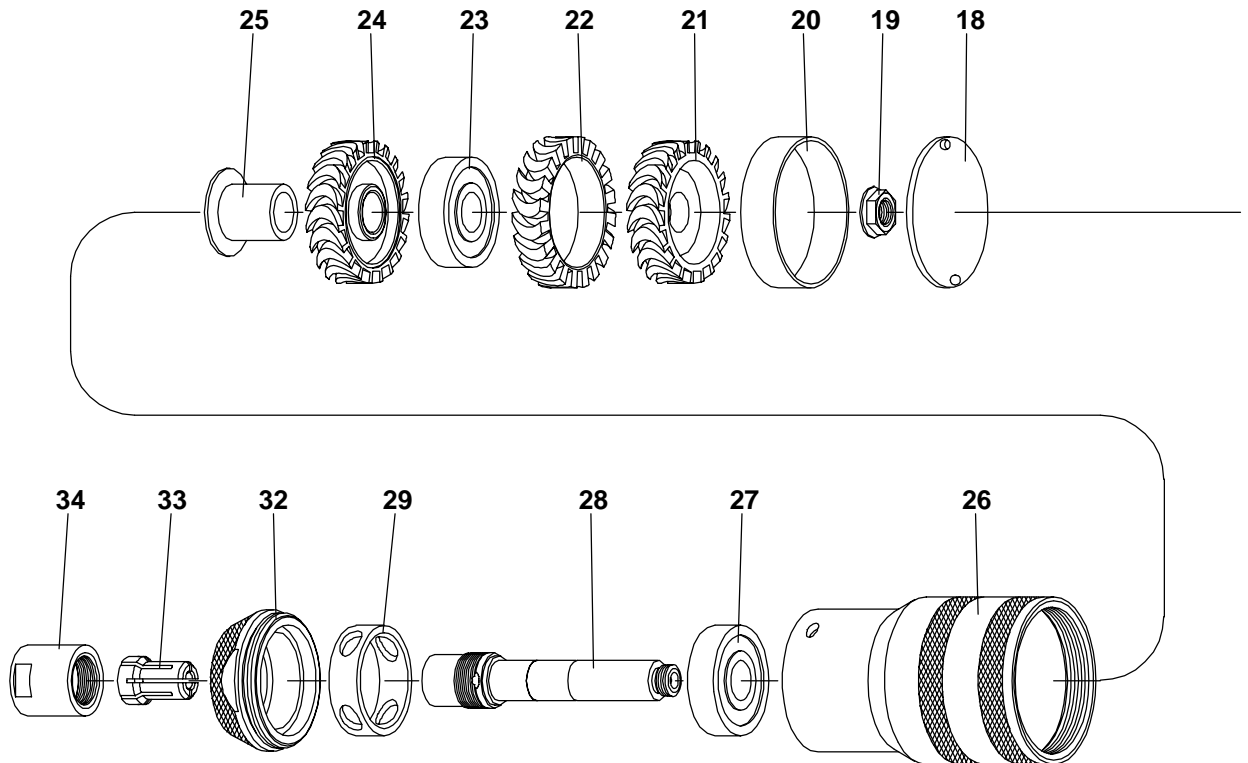

**NOT SHOWN**  
**30131 WRENCH**  
**04662532 WARNING LABEL (NON-EU MODELS)**  
**39853 HOSE ASSEMBLY**  
**48176-1 WARNING LABEL (NON-EU MODELS)**  
**49883 WARNING LABEL (-EU MODELS)**

PART NUMBER FOR ORDERING

PART NUMBER FOR ORDERING

1	Nut .....	36906	14	Lever .....	45952
2a	Throttle and Bushing Assembly .....		15	Roll Pin .....	Y178-5
2b	Head Assembly .....		16	Spring .....	45778
2	Head and Throttle Assembly (includes items 2a and 2b) for non "-EU" models .....	36920-1	17	Arm .....	45777
	for "-EU" models .....	49939-1		Lev Assembly (includes items 14 thru 17) .....	45953
3	"O" Ring (2 req'd) .....	Y325-15	18	Nozzle Plate .....	36907
4	Roll Pin .....	36918	19	Nut .....	32798
	Head and Throttle Assembly (includes items 1 thru 4) for non "-EU" models .....	36920	20	Sleeve .....	36908
	for "-EU" models .....	49939	21	Impeller .....	36909
5	Lever .....	43885	22	Impeller .....	36910
6	Roll Pin .....	Y178-44	23	Ball Bearing .....	36913
7	Throttle Valve Head .....	38947	24	Impeller .....	36911
8	"O" Ring .....	Y325-211	25	Spacer .....	36919
9	"O" Ring .....	Y325-5	26	Housing for non "-EU" models .....	36901
10	Stem Valve .....	33032		for "-EU" models .....	49901
11	Spring .....	31125	27	Ball Bearing .....	36913
12	Seal .....	32886	28	Spindle .....	36902
13	Throttle Valve Screw .....	33023	29	Lock Sleeve .....	43881
	Head Assembly (includes items 7 thru 13) .....	38949-1	32	Housing Cap .....	36912
			33	Collet .....	31812-4
			34	Nosepiece .....	36914

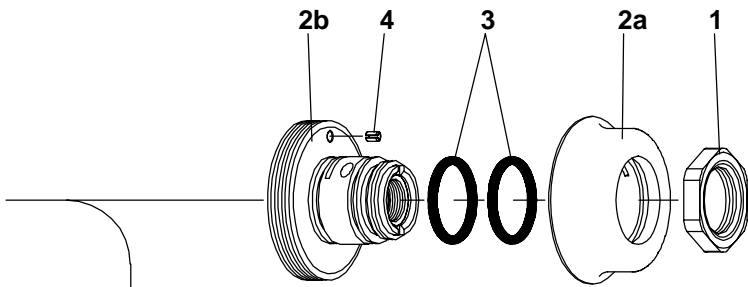

**MODEL 7980-A-()**

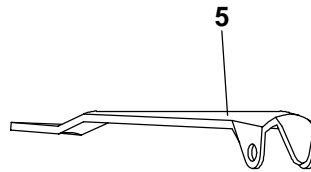

**MODEL 7980-2**

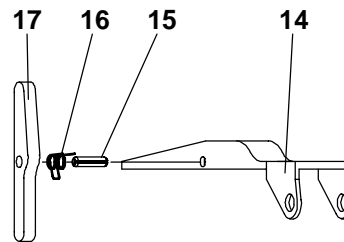
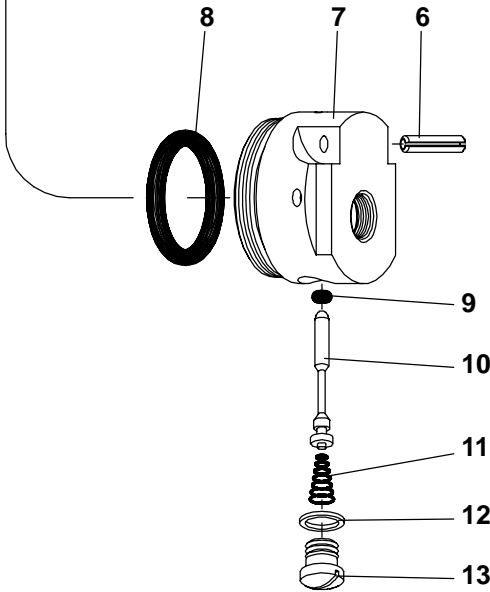

**MODEL 7980-2-EU**

## DISASSEMBLY/ASSEMBLY INSTRUCTIONS

### NOTICE

- Never apply excessive pressure by a holding device which may cause distortion of a part.
- Apply pressure evenly to parts which have a press fit.
- Apply even pressure to the bearing race that will be press fitted to the mating part.
- Use correct tools and fixtures when servicing this tool.
- Don't damage "O" rings when servicing this tool.
- Use only genuine ARO replacement parts for this tool. When ordering, specify part number, description, tool model number and serial number.
- Remove impellers (21, 22 and 24), sleeve (20), bearing (23) and spacer (25) from housing.
- Do not remove bearing (27) from spindle unless damage is evident. To remove, press off of spindle.
- Models 7980-2-() – Remove valve screw (13) and seal (12), releasing spring (11), stem valve (10) and "O" ring (9).
- Models 7980-A-() – To remove "O" rings (3), remove nut (1), releasing throttle and bushing assembly (2a).

### ASSEMBLY

- #### DISASSEMBLY
- Remove hose assembly (not shown) from the inlet of the tool.
  - Insert A 1/8" diameter pin thru the hole in the housing (26), lock sleeve (29) and spindle (28).
  - Using a wrench on flats of housing cap (32), unthread and remove housing cap (32) and lock sleeve (29).
  - Using a wrench on flats of nosepiece (34), unthread and remove from spindle, releasing collet (33).
  - Models 7980-2-() – Place head (7) in a vise and, using a strap type wrench, unthread and remove housing (26).
  - Models 7980-A-() – Clamp wrench (30131) flatwise in a vise and place slot in air inlet of tool on wrench. Using a strap type wrench, unthread and remove housing (26).
  - Remove nozzle plate (18).
  - Insert a 1/8" diameter pin thru the hole in housing (26) and spindle (28), and remove nut (19).
  - Press spindle (28) out nose end of housing.
  - Assemble bearing (27) to spindle (28), pressing on inner race of bearing.
  - Assemble spindle into housing thru nose end, pressing on outer race of bearing.
  - Assemble spacer (25), impeller (24), impeller (22) with bearing (23) and impeller (21) with sleeve (20) to spindle, securing with nut (19). NOTE: Assemble impellers with grooves in the direction shown on page 4.
  - Assemble nozzle plate (18) and head to tool.
  - Assemble lock sleeve (29) to housing, aligning hole in lock sleeve (29) with hole in housing.
  - Insert a 1/8" diameter pin thru hole in housing and lock sleeve (29).
  - Assemble housing cap (32) to housing, tightening securely.
  - Assemble collet (33) and nosepiece (34) to spindle.
  - Models 7980-2-() – Grease and assemble "O" ring (9) to stem valve (10). Assemble stem valve (10) and spring (11) to head, securing with seal (12) and valve screw (13).

**TYPICAL CROSS SECTION OF TOOL**

**M10  
25**

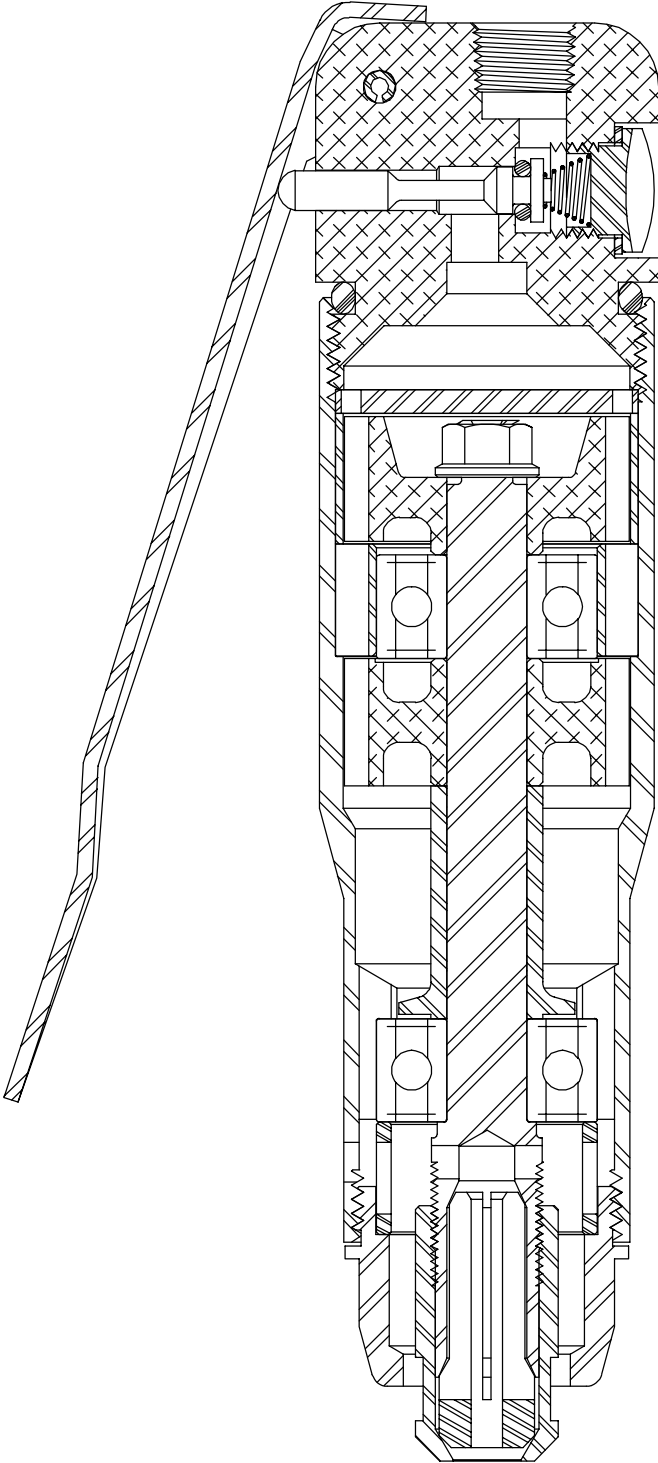

**MODEL 7980-2**

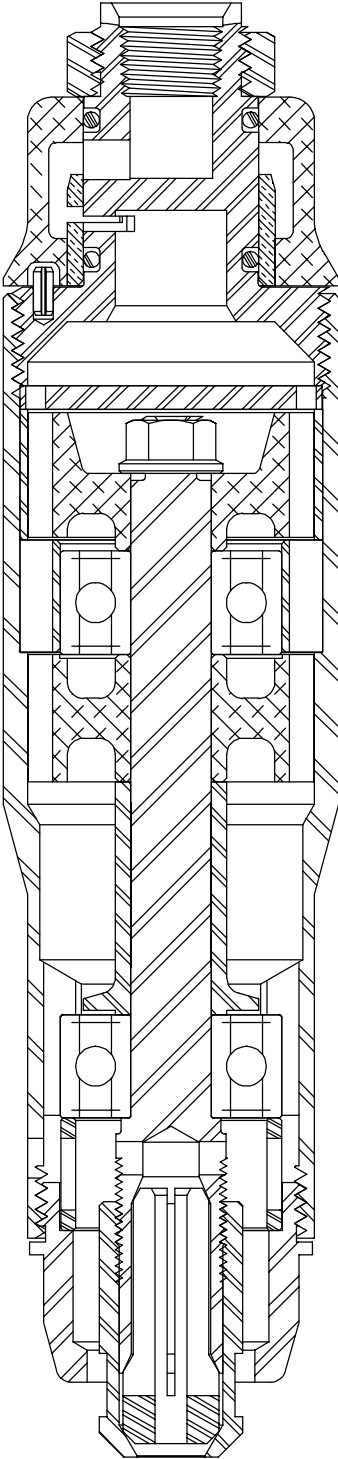

**MODEL 7980-A-()**

**TYPICAL CROSS SECTION OF TOOL**

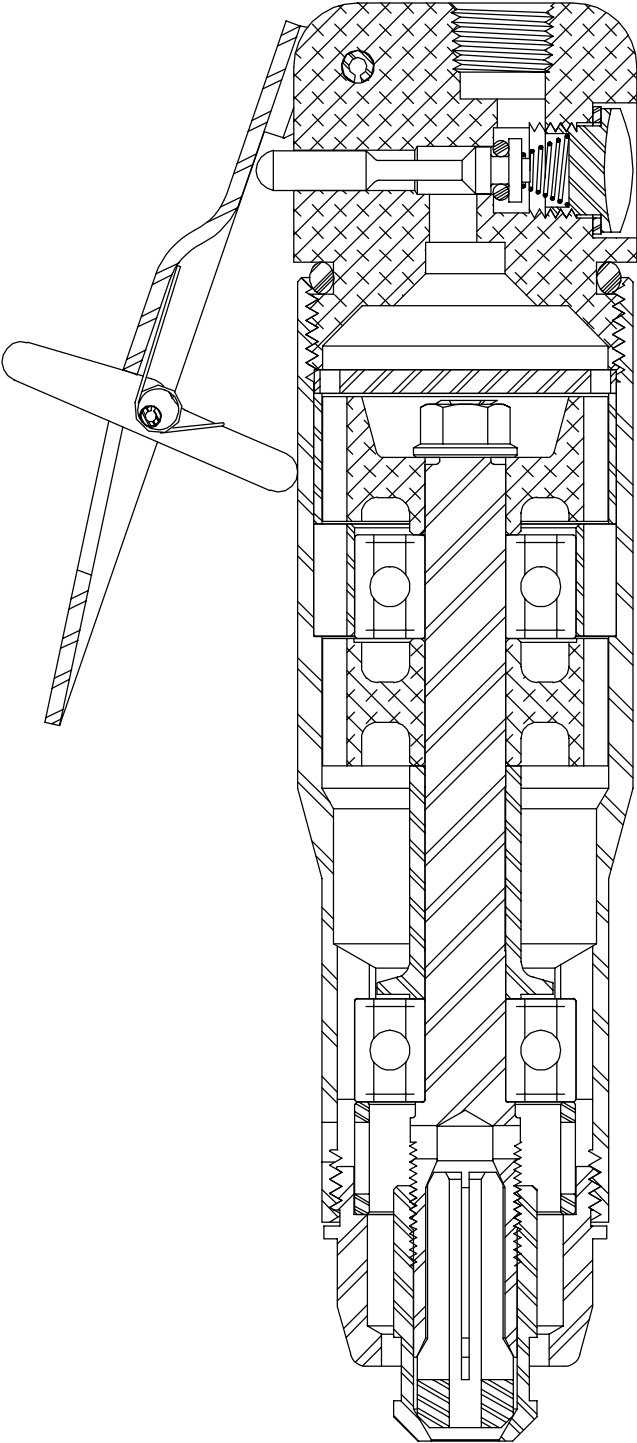

**MODEL 7980-2-EU**

