



10569408  
Edition 1  
January 2006

# Air Impact Wrench

Series 3940, 3942 & 3955

---

## Maintenance Information



**Save These Instructions**

***IR*** Ingersoll-Rand®

## WARNING

Always wear eye protection when operating or performing maintenance on this tool.

Always turn off the air supply and disconnect the air supply hose before installing, removing or adjusting any accessory on this tool, or before performing any maintenance on this tool.

**Note:** When reading the instructions, refer to exploded diagrams in Parts Information Manuals when applicable (see under Related Documentation for form numbers).

## Lubrication

Each time a Series 3940, 3942 or 3955 Impactool is disassembled for maintenance and repair or replacement of parts, lubricate the tool as follows:

1. Work approximately 12 to 15 cc of **Ingersoll-Rand** No. 170 Grease into the impact mechanism. Coat the Anvil (38) lightly with grease.

Also, coat the inside of the Hammer Case Bushing (40) with grease. Inject approximately 2 to 4 cc of grease into the Grease Fitting (2).

2. Use **Ingersoll-Rand** No. 10 Oil for lubricating the motor. Inject approximately 1 to 2 cc of oil into the Straight Inlet (10) before attaching the air hose.

## Disassembly

### General Instructions

1. Do not disassemble the tool any further than necessary to replace or repair damaged parts.
2. Whenever grasping a tool or a part in a vise, always use leather-covered or copper-covered vise jaws to protect the surface of the part and help prevent distortion. This is particularly true of threaded members and housings.
3. Do not remove any part which is a press fit in or on a subassembly unless the removal of that part is necessary for repairs or replacement.
4. Do not disassemble the tool unless you have a complete set of new gaskets and O-rings for replacement.

4. With Anvil removed, lift out the two Hammer Pins.
5. Remove the Hammers.

### Disassembly of the Reverse Valve

1. Lightly clamp Motor Housing Assembly (26) in leather-covered or copper-covered vise jaws with Handle Assembly (1) upward.

#### NOTICE

**Excessive clamping pressure will distort the Motor Housing and make motor removal extremely difficult. Do not insert the hammer case end of the Motor Housing more than 1" (25 mm) into the vise jaws.**

2. Using a hex wrench, unscrew and remove the four Handle Cap Screws (15). Lift assembled handle and Handle Gasket (17) off Motor Housing and set them aside.
3. Lift Motor Clamp Washer(s) (16) off Housing.
4. Move Reverse Lever (12) to center position and using a drift pin to push from below, grasp Lever and lift Reverse Valve Assembly (13) out of Housing.

#### NOTICE

**Make certain the Lever is in the center position to avoid jamming the Reverse Lock Plunger (30) when the Reverse Valve Assembly is removed.**

5. Pull Lever off Reverse Valve and remove Reverse Valve Bushing Seal (14) from groove on Valve.
6. Using needle nose pliers, remove Reverse Lock Plunger and Reverse Lock Plunger Spring (31) from Motor Housing.

### Disassembly of the Motor

1. Remove assembled motor and Motor Housing from vise jaws and using a plastic hammer, tap splined shaft of Rotor (22) to dislodge Rotor from Front Rotor Bearing (25).
2. Lift Motor Housing (26) off Rotor, Rear End Plate (20) and Rear Rotor Bearing (18) which will remain together as a unit.
3. Remove Vanes (23) from Rotor.
4. Pull Rear End Plate off Rotor.
5. Open a set of vise jaws wide enough to clear hub of Rear End Plate and sharply rap hub end of end plate on top of jaws to dislodge Rear Rotor Bearing.
6. Remove Cylinder Dowel (19).
7. **For 3940 and 3942 Series:** To remove Cylinder (21) and Front End Plate (24), thread four 1/4"-20 thread socket head cap screws that are at least 3" (75 mm) long into handle end of Housing. Grasping Housing with installed screws downward, sharply strike heads of screws on a sturdy table to dislodge Cylinder. Cylinder should drop out of Housing after a few impacts. If it does not, proceed as follows:  
**For 3955 Series:** To remove Cylinder (21) and Front End Plate (24), thread four 5/16"-18 thread socket head cap screws that are at least 3" (75 mm) long into handle end of Housing. Grasping Housing with installed screws downward, sharply strike heads of screws on a sturdy table to dislodge Cylinder. Cylinder should drop out of Housing after a few impacts. If it does not, proceed as follows:

### Disassembly of the Impactool

1. Grasp tool in copper-covered or leather-covered vise jaws with square drive upward.
2. Squeeze sides of the Exhaust Deflector (32) and remove from Motor Housing Assembly (26). Remove the Exhaust Silencer (33).
3. Using a hex wrench, unscrew and remove the four Hammer Case Cap Screws (41) and remove Dead Handle Bracket (42).
4. While lightly tapping on the end of Anvil (38) with a plastic hammer, lift off Hammer Case (39).
5. Remove the Hammer Case Gasket (34).
6. Remove Anvil by rotating it as it is lifted out of the assembly.
7. Lift remaining hammer assembly off rotor shaft.
8. Push two Hammer Pins (36) out of the Hammer Frame Assembly (35) and slide two Hammers (37) out of the Frame.

### Disassembly of the Impact Mechanism

1. Set mechanism, driver end up, on a workbench.

#### NOTICE

**Note the twin hammers within the Hammer Frame. These are identical, but must be placed in the Hammer Frame in a certain relationship. Using a felt-tipped pen, mark the top hammer "T↑" and the bottom hammer "B↑" with the arrows pointing upward. Mark both Hammers on the same end.**

2. With mechanism sitting upright on a workbench, slowly rotate Anvil in a clockwise direction until it comes up solid.

#### NOTICE

**If you continue to rotate the Anvil, it will cam the Hammers out of engagement. Do not allow this to happen; merely rotate the Anvil until it comes up solid.**

3. Hold Hammer Frame firmly and, without disturbing hammers, gently lift Anvil, simultaneously rotating it clockwise about 1/8 of a turn, from the Hammer Frame.

#### NOTICE

**The twin hammers will be free to slide from the Hammer Frame when the Hammer Pins are removed. Do not drop the Hammers.**

## WARNING

The following procedure requires the use of heat. Take all necessary precautions to prevent burns. Carefully heat alternate sides of Housing until it is very warm. Using thick, heavy gloves to avoid being burned, grasp Housing and repeat attempt to dislodge Cylinder.

8. Open a set of vise jaws wide enough to clear hub of Front End Plate and sharply rap hub end of end plate on top of jaws to dislodge Front Rotor Bearing.

## Assembly

### General Instructions

1. Always press on the **inner** ring of a ball-type bearing when installing the bearing on a shaft.
2. Always press on the **outer** ring of a ball-type bearing when installing the bearing into a bearing recess.
3. Whenever grasping a tool or part in a vise, always use leather-covered or copper-covered vise jaws. Take extra care with threaded members and housings.
4. Always clean every part and wipe every part with a thin film of oil before installation.
5. Apply a film of O-ring lubricant to all O-rings before final assembly.

### Assembly of the Handle

1. Position Trigger (3) in Handle (1) and using an arbor press, push Trigger Pin (4) full length into Handle so that it captures Trigger.
2. Clamp Handle in leather-covered or copper-covered vise jaws with air inlet opening upward.
3. Coat Throttle Valve Plunger (5) with oil and insert it, rounded end leading, into the inlet hole in Handle.
4. Install a new Throttle Valve Seal (7) on Throttle Valve (6) and insert assembly, Valve Seal leading, into inlet hole in Handle.
5. Encircle cone end of Air Strainer Screen (9) with large end of Throttle Valve Spring (8) and insert both parts, Spring leading, into the inlet hole in Handle.
6. Install Straight Inlet (10) over Strainer Screen in Handle and tighten Inlet between 50 and 60 ft-lb (68 and 81 Nm) torque.
7. Remove Handle from vise and test Trigger. If Trigger functions properly, place assembled Handle aside. If it does not function properly, disassemble Handle to determine cause of problem.

### Assembly of the Motor

1. Lightly clamp Motor Housing (26) in leather-covered or copper-covered vise jaws with handle end upward.

## NOTICE

**Excessive clamping pressure will distort the Motor Housing and make motor installation extremely difficult. Do not insert the hammer case end of the Motor Housing more than 1" (25 mm) into the vise jaws.**

2. Grease Front Rotor Bearing (25) and install it in recess of Front End Plate.
3. Coat inside surface of Housing and outer edge of Front End Plate (24) with a light film of oil.
4. Using a long tee hex wrench as an alignment pin, insert Front End Plate, copper face trailing, into Motor Housing. Align dowel hole in End Plate with dowel hole at the bottom of motor bore.
5. Lubricate and insert a new fiber Air Port Gasket Retainer (28) in one of the air ports inside Motor Housing.
6. Install an Air Port Gasket (29) in the air port against Gasket Retainer with flat end of Gasket away from Retainer.
7. Repeat Steps 5 and 6 to install remaining Gasket and Retainer in the other air port.
8. Coat outside of Cylinder (21) with a light film of oil and using long tee hex wrench as an alignment pin to align the holes in Cylinder with holes in Front End Plate and Housing, insert Cylinder into Housing.

9. Remove two Air Port Gaskets (29) and Air Port Gasket Retainers (28) from Housing.

### Disassembly of the Handle

1. Clamp Trigger Handle Assembly in leather-covered or copper-covered vise jaws with the Straight Inlet (10) upward.
2. Using a wrench, unscrew and remove Inlet as well as Air Strainer Screen (9) and valve Spring (8).
3. Remove Throttle Valve Assembly (6) and Valve Plunger (5) from Handle.
4. If Trigger (3) must be removed, use an arbor press to push Trigger Pin (4) from the Handle and slide Trigger out of slot in Handle.

9. Coat inside of Cylinder and Rotor (22) with a light film of oil and insert the splined hub of Rotor through Cylinder into Front End Plate.
10. Coat each Vane (23) with a light film of oil and insert a Vane into each slot in the Rotor. Vanes must be installed with curved edge toward center of Rotor. Spin the Rotor to settle Vanes in position.
11. Using long tee hex wrench to align hole in Rear End Plate (20) with hole in Cylinder, insert the Rear End Plate, bronze face leading, into Motor Housing against the Cylinder. End Plate is properly seated when large trailing face of End Plate is slightly below face of Motor Housing.
12. Grease Rear Rotor Bearing (18) and install it in recess of Rear End Plate.
13. Remove alignment pin from assembled motor and install Cylinder Dowel (19). The Dowel is properly seated when end of Dowel does not protrude above End Plate.
14. Install Motor Clamp Washer(s) (16) against Rear End Plate so that large outer edge of Washer contacts End Plate.

### Assembly of the Reverse Valve

1. Inject a small amount of grease into hole in Motor Housing (26) where Reverse Lock Plunger (30) will be installed. With grease to hold them in position, install Reverse Lock Plunger Spring (31) and Lock Plunger.
2. Install a new Reverse Valve Bushing Seal (14) in annular groove on Reverse Valve (13).
3. Coat Reverse Valve with a light film of oil and install it in Motor Housing with the side hole nearest to Seal pointed toward Rotor (22).
4. Position Reverse Lever (12) on Reverse Valve and while using a thin blade screwdriver to depress Reverse Lock Plunger, push Lever onto Reverse Valve.
5. Place a new Handle Gasket (17) on the Motor Housing.
6. Examine Reverse Valve Seal (11) located inside Handle and if it is nicked, deformed or worn, remove it and install a new Seal.
7. Fill rotor cavity in Handle with recommended grease and position Handle on the Motor Housing.
8. **For 3940 and 3942 Series:** Install four Handle Cap Screws (15) and using an alternate tightening pattern, tighten Screws to between 10 and 12 ft-lb (14 and 16 Nm) torque.  
**For 3955 Series:** Install four Handle Cap Screws (15) and using an alternate tightening pattern, tighten Screws to between 25 and 28 ft-lb (34 and 38 Nm) torque.
9. Move Reverse Lever through the forward and reverse positions to make certain the Lever locks in position.
10. Turn assembly in vise jaws and clamp on Handle with rotor shaft upward.
11. Pack Front Rotor Bearing with additional grease and rotate rotor shaft. If shaft does not rotate smoothly, rap end of rotor shaft with a soft hammer to set motor and try to rotate shaft again.

## Assembly of the Impact Mechanism

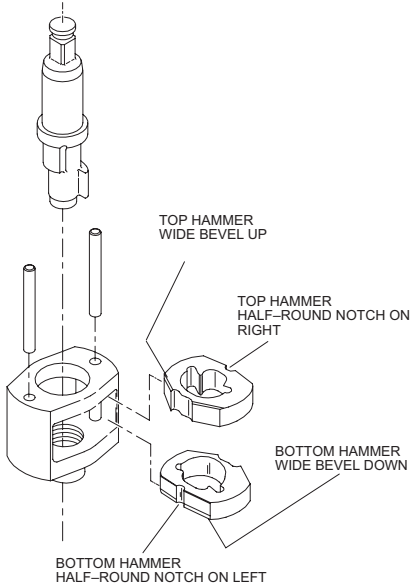

(Dwg. TPD652)

1. Coat Hammers (37) with a light film of Ingersoll-Rand Impactool Grease No. 170.
2. Replace Hammers in Hammer Frame (35) exactly as they were when you marked them prior to disassembly.

### NOTICE

If you are installing new Hammers, or want to change the location of the existing Hammers to utilize both impacting surfaces, slide the Hammers in the Hammer Frame so that the half-round notch on one Hammer is located on one side of the Frame and the half-round notch on the other Hammer is located on the other side of the Frame.

3. Replace Hammer Pins (36).
4. Examine base of Anvil (38) and note its contour. While looking down through Hammer Frame, swing the top Hammer to its full extreme one way or another until you can match the contour of the Anvil. Enter the Anvil into the Hammer Frame and through the first Hammer. Swing the bottom Hammer in opposite direction from the top Hammer and maneuver Anvil slightly until it drops into bottom Hammer.

## Assembly of the Impactool

1. Set assembled hammer mechanism onto rotor shaft spline.
2. Place Hammer Case Gasket (34) over mechanism and against face of Motor Housing.
3. Grease Anvil and top of Hammer Frame.
4. Place Hammer Case (39) over mechanism assembly against Gasket.
5. Assemble Dead Handle (43) to Dead Handle Bracket (42). Insert two Hammer Case Cap Screws (41). Position assembly against Hammer Case and thread the Screws into Housing.
6. **For 3940 and 3942 Series:** Thread remaining two Cap Screws into Housing and using an alternating pattern for all four fasteners, tighten Screws between 20 and 25 ft-lb (27 and 34 Nm) torque.  
**For 3955 Series:** Thread remaining two Cap Screws into Housing and using an alternating pattern for all four fasteners, tighten Screws between 35 and 40 ft-lb (47 and 54 Nm) torque.
7. Install a new Exhaust Silencer (33) in Motor Housing Assembly (26) and install the Exhaust Deflector (32).

## Troubleshooting Guide

Trouble	Probable Cause	Solution
Low power	Dirty Inlet Bushing or Air Strainer Screen and/or Exhaust Silencer.	Using a clean, suitable, cleaning solution, in a well ventilated area, clean Air Strainer Screen, Inlet Bushing and Exhaust Silencer.
	Worn or broken Vanes.	Replace the <b>complete</b> set of Vanes.
	Worn or broken Cylinder and/or scored End Plates.	Examine the Cylinder and replace it if it is worn or broken or if the bore is scored or wavy. Replace the End Plates if they are scored.
	Dirty motor parts.	Disassemble tool and clean all parts with a suitable cleaning solution, in a well-ventilated area. Reassemble tool as instructed in this manual.
	Improper positioning of the Reverse Valve.	Make certain that the Reverse Valve is <b>fully</b> engaged to the left or right.
Motor will not run	Incorrect assembly of the motor.	Disassemble the motor and replace worn or broken parts and reassemble as instructed.
	Insufficient lubricant in the impact mechanism.	Remove the Hammer Case Assembly and lubricate the impact mechanism.
Tool will not impact	Broken or worn impact mechanism parts.	Remove the Hammer Case and examine the impact mechanism parts. Replace any worn or broken parts.
	Impact Mechanism not assembled correctly.	Refer to <b>Assembly of the Impact Mechanism</b> .

## Related Documentation

For additional information refer to:  
 Air Impact Wrench Product Safety Information Manual 04580916.  
 Air Impact Wrench Product Information Manuals 10569382 and 80160716.  
 Air Impact Wrench Parts List Manuals 10569390 and 80160724.







[www.irtools.com](http://www.irtools.com)

© 2006 Ingersoll-Rand Company

