

SECTION 9: PARTS

Parts Breakdown

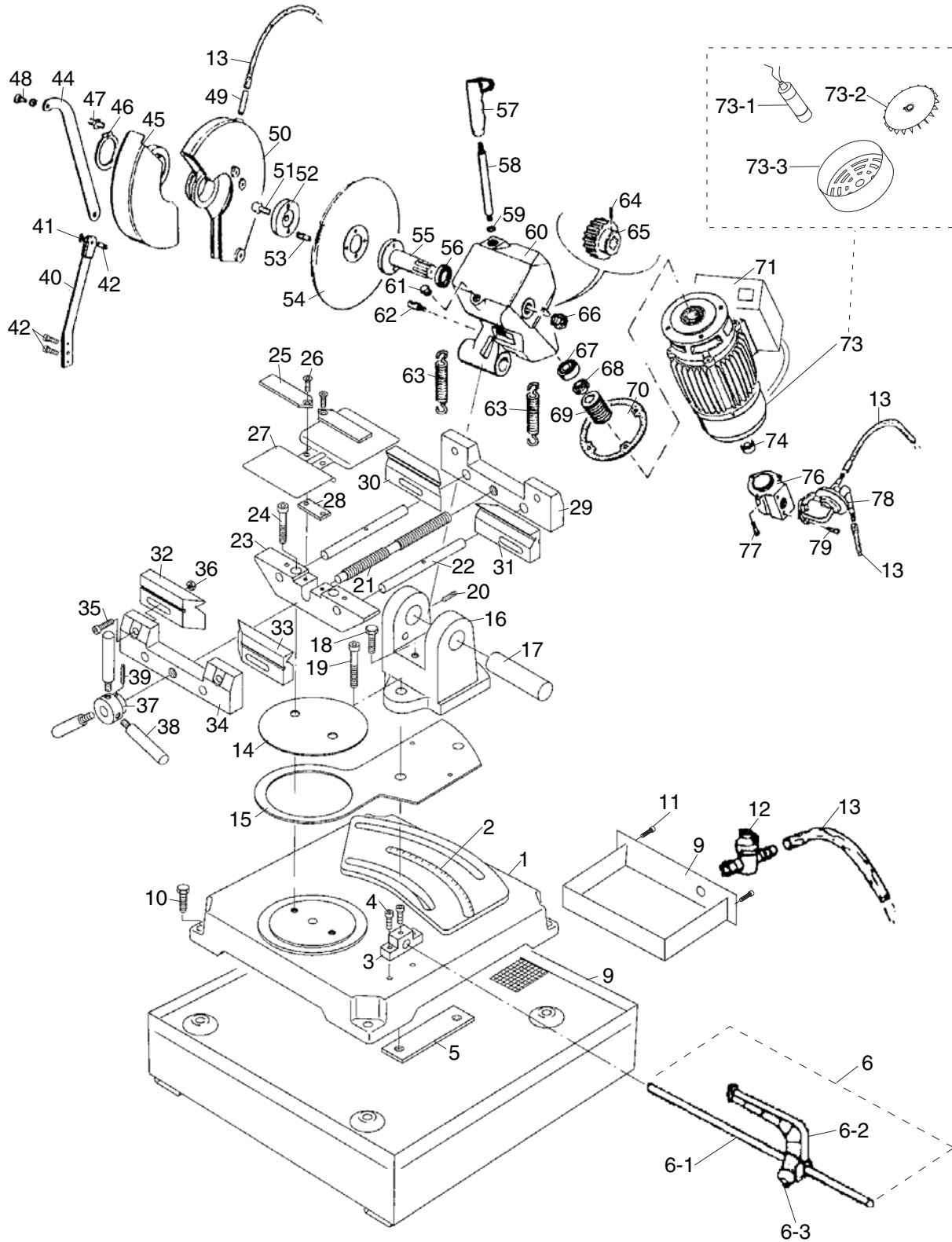

Parts List

REF	PART #	DESCRIPTION
1	P0681001	BASE
2	P0681002	SCALE
3	P0681003	WORK STOP SUPPORT
4	PSB26M	CAP SCREW M6-1 X 12
5	P0681005	PLATE
6	P0681006	WORK STOP ASSEMBLY
6-1	P0681006-1	WORK STOP ROD
6-2	P0681006-2	WORK STOP
6-3	PSB06M	CAP SCREW M6-1 X 25
9	P0681009	COOLANT TANK
10	PB26M	HEX BOLT M8-1.25 X 30
11	PSB110M	CAP SCREW M4-.7 X 6
12	P0681012	COOLANT TAP
13	P0681013	COOLANT TUBE
14	P0681014	STATIONARY PLATE
15	P0681015	ROTATING PLATE
16	P0681016	PIVOT BLOCK
17	P0681017	PIVOT PIN
18	PB07M	HEX BOLT M8-1.25 X 25
19	PSB60M	CAP SCREW M8-1.25 X 55
20	PSS06M	SET SCREW M8-1.25 X 16
21	P0681021	LEADSCREW
22	P0681022	WISE PIN
23	P0681023	WISE SUPPORT
24	PSB13M	CAP SCREW M8-1.25 X 30
25	P0681025	WISE BASE PLATE
26	PFH48M	FLAT HD SCR M8-1.25 X 18
27	P0681027	WISE COVER
28	P0681028	SPACER
29	P0681029	WISE CLAMP REAR
30	P0681030	WISE JAW LR
31	P0681031	WISE JAW RR
32	P0681032	WISE JAW LF
33	P0681033	WISE JAW RF
34	P0681034	WISE CLAMP FRONT
35	PSB02M	CAP SCREW M6-1 X 20
36	PN01M	HEX NUT M6-1
37	P0681037	HANDLE BODY
38	P0681038	HANDLE
39	PRP49M	ROLL PIN 5 X 25

REF	PART #	DESCRIPTION
40	P0681040	TIE ROD SUPPORT
41	PLN04M	LOCK NUT M8-1.25
42	PSB14M	CAP SCREW M8-1.25 X 20
44	P0681044	GUARD ROD
45	P0681045	GUARD
46	PR71M	EXT RETAINING RING 60MM
47	PSB01M	CAP SCREW M6-1 X 16
48	PSB11M	CAP SCREW M8-1.25 X 16
49	P0681049	COOLANT NOZZLE
50	P0681050	FIXED GUARD
51	P0681051	CAP SCREW M12-1.5 X 25 LH
52	P0681052	ARBOR FLANGE
53	P0681053	SPECIAL PIN 7 X 12
54	P0681054	SAW BLADE
55	P0681055	ARBOR
56	P0681056	ARBOR BEARING
57	P0681057	HEAD LEVER HANDGRIP
58	P0681058	HEAD LEVER
59	PN13M	HEX NUT M16-2
60	P0681060	SAW HEAD
61	P0681061	OIL PLUG
62	P0681062	SPRING HOOK SCREW
63	P0681063	TENSION SPRING
64	PSS03M	SET SCREW M6-1 X 8
65	P0681065	WORM GEAR
66	P0681066	SIGHT GLASS
67	P6001	BALL BEARING 6001ZZ
68	P0681068	SPECIAL NUT
69	P0681069	WORK SHAFT
70	P0681070	HEAD GASKET
71	P0681071	SWITCH BOX
73	P0681073	MOTOR 1 HP 110V 1-PH
73-1	P0681073-1	R CAPACITOR 45M 250V 2-3/4 X 1-5/8
73-2	P0681073-2	MOTOR FAN
73-3	P0681073-3	MOTOR FAN COVER
74	P609A	BALL BEARING 609ZZ
76	P0681076	PUMP CONNECTION BOX
77	PSB16M	CAP SCREW M4-.7 X 16
78	P0681078	COOLANT PUMP
79	PSB02M	CAP SCREW M6-1 X 20



Control Panel Parts Breakdown

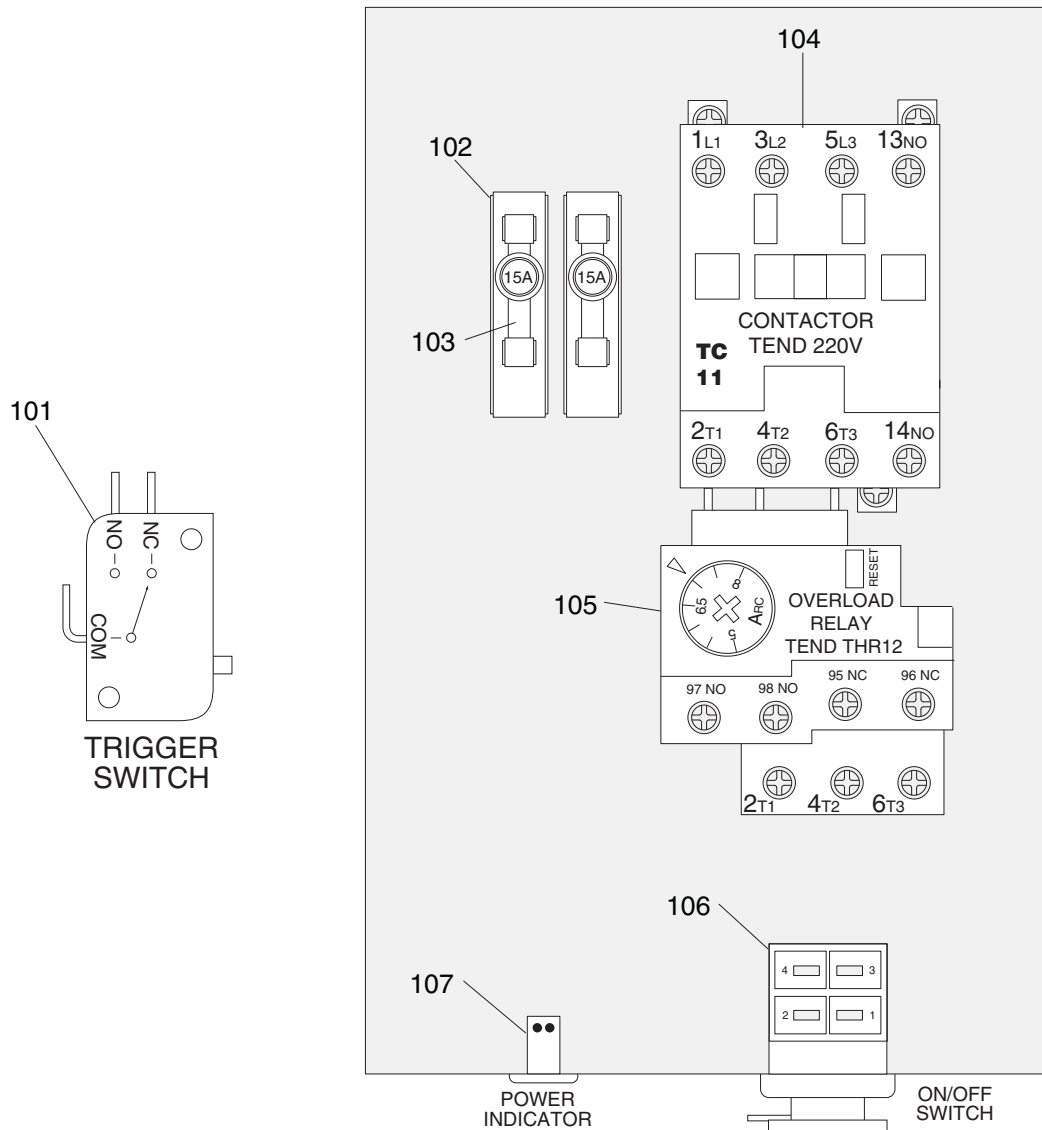

REF	PART #	DESCRIPTION
101	P0681101	TRIGGER SWITCH
102	P0681102	FUSE HOLDER
103	P0681103	FUSE 15A
104	P0681104	CONTACTOR TEND TC11

REF	PART #	DESCRIPTION
105	P0681105	OVERLOAD RELAY TEND THR12
106	P0681106	ON/OFF SWITCH
107	P0681107	INDICATOR LAMP



Warning Labels

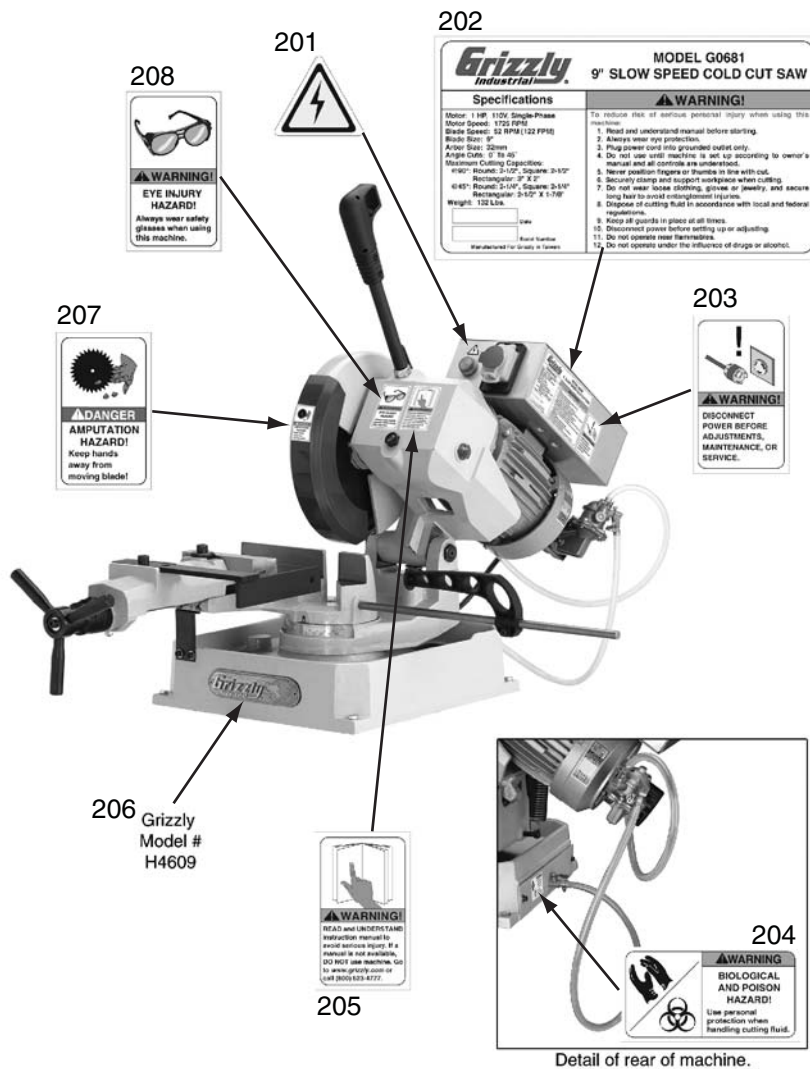

REF	PART #	DESCRIPTION
201	PLABEL-14	ELECTRICITY LABEL
202	P0681202	MACHINE ID LABEL
203	PLABEL-63A	DISCONNECT POWER LABEL
204	P0681204	BIOLOGICAL WARNING LABEL

REF	PART #	DESCRIPTION
205	PLABEL-12C	READ MANUAL LABEL
206	H4609	GRIZZLY NAMEPLATE
207	P0681207	BLADE DANGER LABEL
208	PLABEL-11B	SAFETY GLASSES LABEL

⚠️ WARNING

Safety labels warn about machine hazards and ways to prevent injury. The owner of this machine **MUST** maintain the original location and readability of the labels on the machine. If any label is removed or becomes unreadable, **REPLACE** that label before using the machine again. Contact Grizzly at (800) 523-4777 or www.grizzly.com to order new labels.

