

DIN-A-MITE[®] Style D

Solid-State Power Controller

User's Manual



Please consult this user's manual when you place your new DIN-A-MITE in service. It contains all the necessary information to mount and wire it into the application. This manual also contains all pertinent specifications and semiconductor fusing recommendations. Please refer to national and local electrical code safety guidelines whenever you install electrical equipment.

This DIN-A-MITE product is capable of switching up to 100 amperes single-phase, at 600V~ (ac) at 30°C (86°F), depending on the model selected. It is electrically touch-safe and includes standard back-panel mounting, on-board semiconductor fuses, and a current transformer option for external load current monitoring. Shorted SCR alarm output option is also available.

The DIN-A-MITE Style D mounting footprint matches that of an industry-standard 100-amperes mercury displacement relay. This DIN-A-MITE is CE-approved, UL[®] 508-listed and C-UL[®].



1241 Bundy Boulevard, Winona, Minnesota USA 55987
Phone: +1 (507) 454-5300, Fax: +1 (507) 452-4507
<http://www.watlow.com>

Specifications

Operator Interface

- Command signal input and indication light
- Alarm output and indication light

Amperage

- Single-phase, 80A output maximum at 50°C (122°F) into a resistive load. See the Output Rating Curve chart on page 3.
- Maximum surge current for 16.6 milliseconds, 1,800-amp peak
- Maximum I^2t for fusing: 16,200 A²sec
- Latching current: 500mA minimum
- Holding current: 200mA minimum
- Off-state leakage: 1mA at 25°C (77°F) maximum
- 200KA SCCR type 1 and 2 approved with the recommended fusing (see page 3)

Line Voltage

- 24 to 48V~ (ac) units: 20 minimum to 53V~ (ac) maximum
- 120 to 240V~ (ac) units: 48 minimum to 265V~ (ac) maximum
- 277 to 480V~ (ac) units: 85 minimum to 528V~ (ac) maximum
- 277 to 600V~ (ac) units: 85 minimum to 660V~ (ac) maximum
- 50/60 Hz independent +/- 5%

Control Mode, Zero Cross

- Input Control Signal Type C: V= (dc) input contactor. To increase service life, the cycle time should be less than three seconds.
- Input Control Signal Type K: V~ (ac) input contactor. To increase service life, the cycle time should be less than three seconds.
- Input Control Signal Type F: 4 to 20mA= (dc) variable time base control

Input Command Signal

- **AC contactor**
24V~ ±10%, 120V~ +10% / -25%, 240V~ (ac) +10% / -25% @ 25mA maximum per controlled leg
- Do not use the DIN-A-MITE Vac-input models with a temperature controller that includes an RC snubber circuit across its output. Remove the RC snubber circuit before placing the DIN-A-MITE into service.
- **DC Contactor**
4.5V= to 32V= (dc): maximum current @ 4.5V= (dc) is 6mA per leg. Add 3mA if alarm option is included
- **Loop powered linear current**
4mA= to 20mA= (dc): loop-powered. Input Type F0 and F1 options only. (Requires current source with 6.2V= (dc) available. No more than three DIN-A-MITE inputs connected in series)

Linearity (Input Control Signal Type F)

- Full on point 19.5 to 19.9mA= (dc), maximum voltage of 6.2V peak.
- ±5% input to output power accuracy, 0% to 100% of span (4.3 to 19.7mA or 12.3 to 19.7mA).
- Temperature stability is less than 0.15%/°C change.

Alarm

Shorted SCR Alarm Option

- Alarm state when the input command signal off and a 15A or more load current is detected by the current transformer.

Alarm Output

- Energizes on alarm, non-latching
- Triac 24 to 240V~ (ac) external supply with a current rating of 300mA @ 25°C (77°F), 200mA @ 50°C (122°F), 100mA @ 80°C (176°F) and a holding current of 200 µA with a latching current of 5mA typical

Current Sensing

- On-board current transformer (CT), typically 0.2V~ (ac) output signal per ampere sensed

Agency Approvals

- CE with proper filter:
89/336/EEC Electromagnetic Compatibility Directive
EN 61326: Industrial Immunity Class A emissions
Not suitable for Class B emissions environment
73/23/EEC Low Voltage Directive
EN 50178 Safety Requirements
-  UL® 508-listed and C-UL® File E73741

Input Terminals

- Compression: Will accept 0.13 to 3.3 mm² (26 to 12 AWG) wire
- Torque to 0.5 Nm (4.4 in-lb) maximum with a 3.5 mm (1/8 in) blade screwdriver
- Wire strip length 7 mm (0.28 in)

Line and Load Terminals

- Compression: Will accept 13.3 to 34 mm² (6 to 2 AWG) wire
- Torque to 9.0 to 10.1 Nm (80 to 90 in-lb) maximum with a 3/16 inch Allen head
- Wire strip length 17.5 mm (0.69 in)

Operating Environment

- Operating temperature range: 0 to 85°C (32°F to 185°F)
- 0 to 90% RH (relative humidity), non-condensing
- Vibration: 2 g, 10 Hz to 150 Hz, applied in any one of three axes
- Storage temperature: -40 to 85°C (-40°F to 185°F)
- Insulation tested to 3,000 meters
- Installation Category III, pollution degree 2

Mounting

- Standard back panel mounting; fits the same mounting pattern as a 100 A, single-phase mercury displacement relay
- Mounting holes offer clearance for an M5 (No. 10) screw
- On-board semiconductor fusing, Bussmann part number 170N3437

Dimensions

- Height: 185 mm (7.28 in)
- Width: 66 mm (2.58 in)
- Depth: 239 mm (9.41 in)
- Weight: 2.9 kg (6.3 lb)

Specifications are subject to change without notice.

Ordering Information

DIN-A-MITE Style D, solid-state power controller

Part Number D D 1 0 -

Phase

1 = Single-phase, one controlled leg

Cooling and Current Rating

0 = Natural convection; current rating 80A @ 50°C (122°F)
 Note: See the output rating curve for the current rating at other temperatures.

Line and Load Voltage

02 = 24 to 48V~ (ac)
 24 = 120 to 240V~ (ac)
 48 = 277 to 480V~ (ac)
 60 = 277 to 600V~ (ac)

Input Control Signal

C0 = 4.5 to 32V= (dc) contactor
 F0 = 4 to 20mA= (dc) proportional
 F1 = 12 to 20mA= (dc) proportional
 K1 = 22 to 26V~ (ac) contactor
 K2 = 100 to 120V~ (ac) contactor
 K3 = 200 to 240V~ (ac) contactor

Current Sensing or Alarm

0 = None
 1 = Load current transformer
 S = Shorted SCR alarm

User Manual Language

0 = English
 1 = German
 2 = Spanish
 3 = French

Custom Options

00 = Standard

Note:

- Recommended fusing options to meet 200KA SCCR, type 1 and 2 approved. All other fuse combinations are defaulted to 5KA SCCR per UL508A and NEC guidelines.

Watlow part number: 0808-0096-0000

Bussmann part number: 170N3437

Output Rating Curve

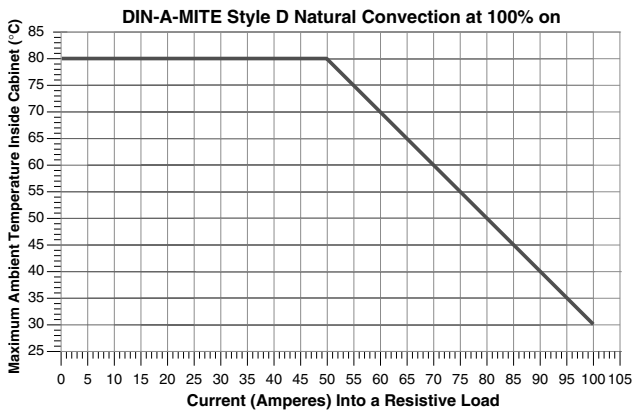

Unit Dimensions

Side

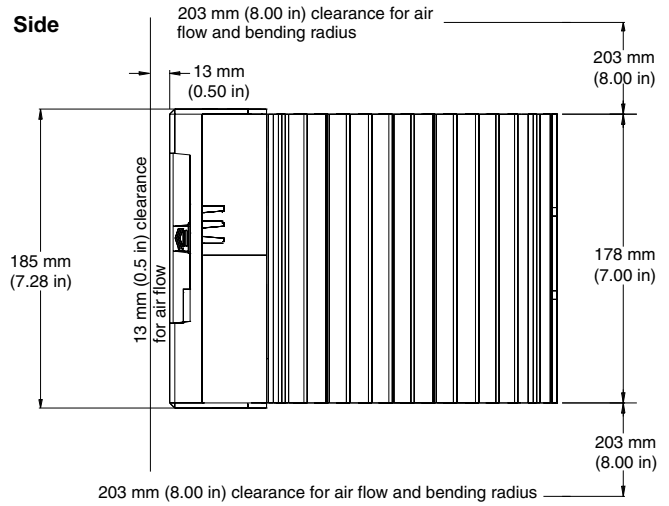

Top

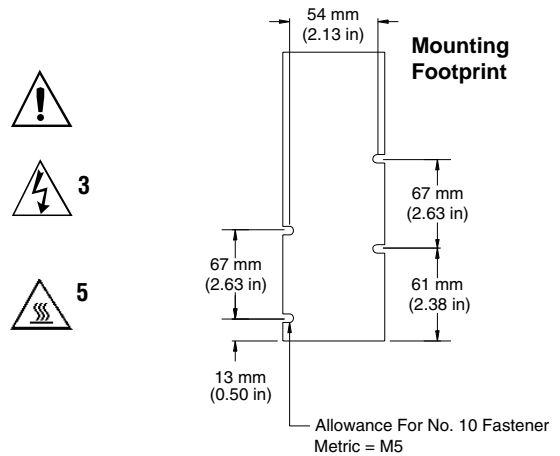
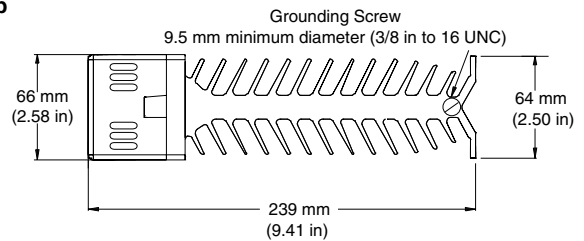

WARNINGS:



3 WARNING: Only authorized and qualified personnel should be allowed to install and perform preventive and corrective maintenance on this unit. Failure to do so could result in damage to equipment, and personal injury or death.



5 WARNING: Hot surface, do not touch the heat sink. Failure to follow this guideline could result in personal injury.

System Wiring Example

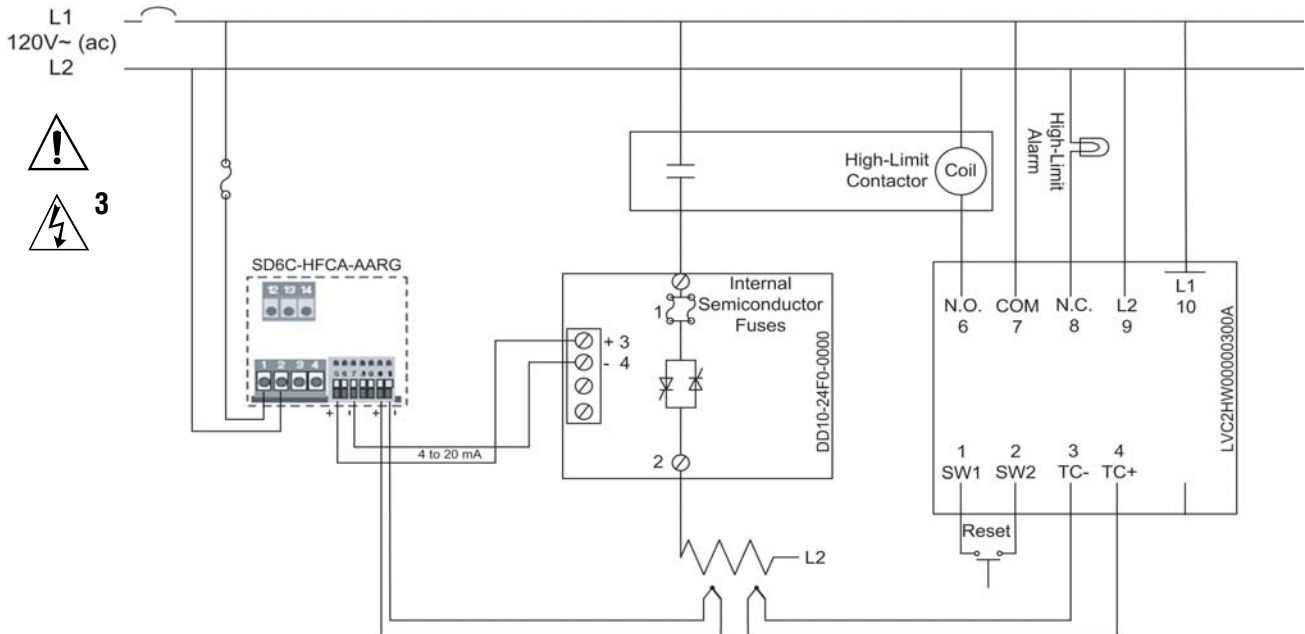

WARNINGS:



1 WARNING: Use National Electric (NEC) or other country-specific standard wiring practices to install and operate the DIN-A-MITE. Failure to do so may result in damage to equipment and property, and/or injury or loss of life.



2 WARNING: Wiring examples show L2 in phase-to-phase, 200V~ (ac) and above configuration. In phase-to-neutral, 100V~ (ac) and above applications, L2 is neutral and must not be fused or switched. Failure to follow this guideline could result in personal injury or death.



3 WARNING: Only authorized and qualified personnel should be allowed to install and perform preventive and corrective maintenance on this unit. Failure to do so could result in damage to equipment, and personal injury or death.



4 WARNING: Do not use the DIN-A-MITE Vac-input models with a temperature controller that includes an RC snubber circuit across its output. Remove the RC snubber circuit before placing the DIN-A-MITE into service.



5 WARNING: Hot surface, do not touch the heat sink. Failure to follow this guideline could result in personal injury.

Fuse Replacement



After removing all power, use a 7/16-inch nut driver to remove fuse mounting nuts. Torque to 4.52 Nm (40 in-lb).

Single-Phase Output and Input Wiring

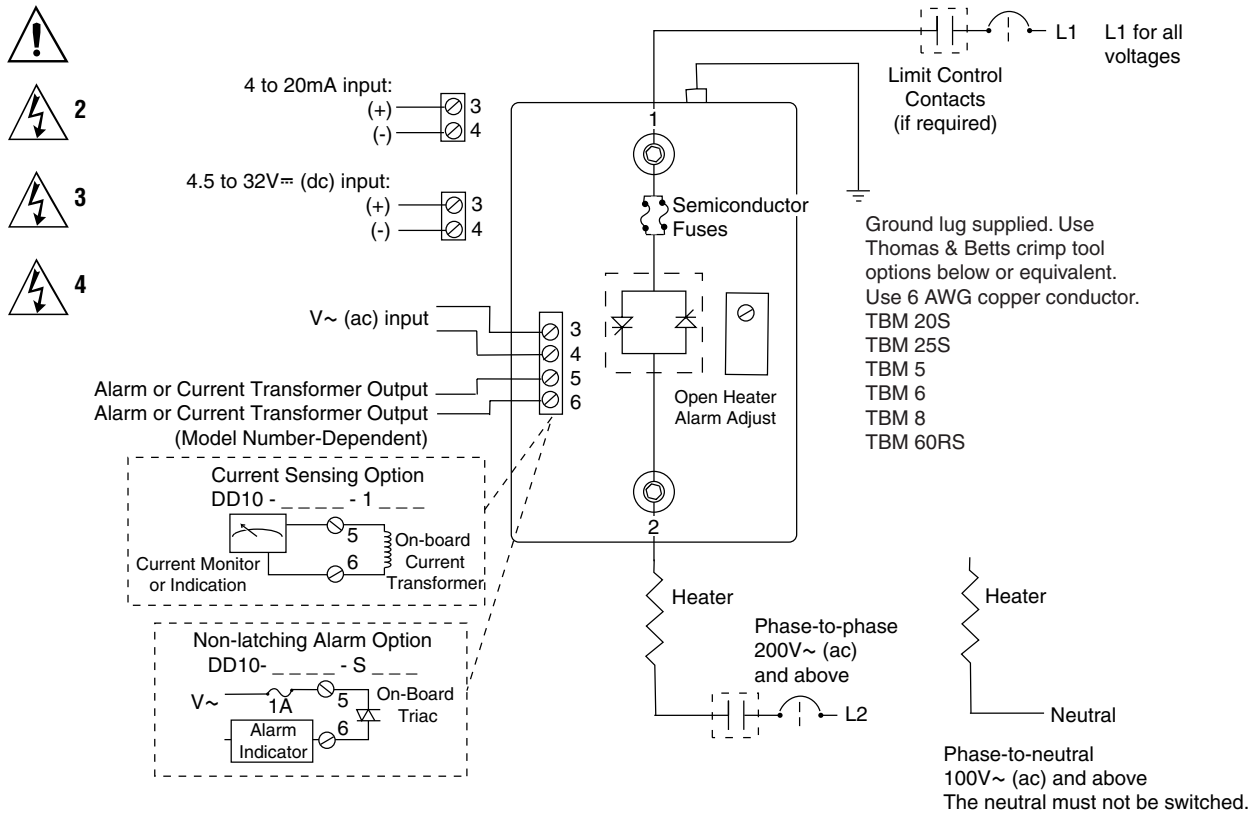

Shorted SCR Alarm

The Watlow DIN-A-MITE alarm option provides an alarm output for shorted SCR conditions. A shorted SCR alarm is detected when there is no command signal and a load current is detected. The alarm output is then energized. **This is a non-latching alarm.**

Torque Procedure

1. While connecting the line and load wires, ensure that all wire strands are inside the connector. **Do not allow loose wire strands to hang out of the connector.** Once you have installed the wire, torque these same connections to 9.0 to 10.1 Nm (80 to 90 in-lb). Use a dial or digital-type torque wrench and hold the torque at 9.0 to 10.1 Nm (80 to 90 in-lb) for 30 seconds. The 30-second hold allows the wire to settle, minimizing the wire cold flow.
2. Re-torque the same connections after 48 hours.
3. Develop a maintenance program to re-torque all load and line connections every three to six months.

NOTE: L1 and L2 terminals are 3/16-inch Allen head screws.

Required External EMI Filters For DIN-A-MITE With More Than 6 A Loads

An external EMI filter must be used in conjunction with the DIN-A-MITE for loads in excess of six amperes (6 A) at 150 to 250 kHz. Without a filter applied, the DIN-A-MITE does not comply with the conducted emissions standard for loads more than 6 A at 150 to 250 kHz.

Watlow has verified that two types of filters will suppress electromagnetic interference (EMI) created by the DIN-A-MITE power controller to within the CE requirements.

A tank filter supplied by Crydom or Watlow, installed across the power lines, suppresses EMI on the power lines. See Figures 1 and 2 below.

See Table 1 for the correct filter.

Description	Crydom Filter	Watlow Filter
Single-phase, 230V~ (ac)	1F25	14-0019
Three-phase, 440V~ (ac)	3F20	14-0020

Table 1 — DIN-A-MITE EMI filters.

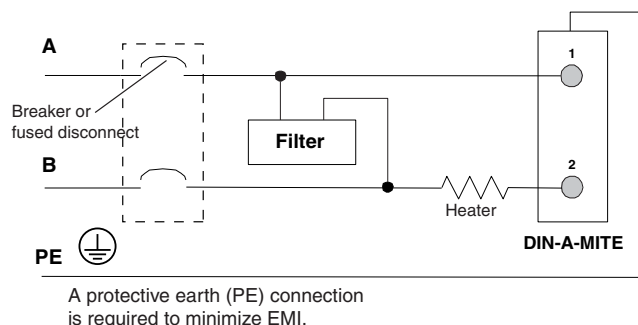

Figure 1 — Tank filter, single-phase, 230V~ (ac).

⚠ WARNING:

The tank filters specified may suppress desirable communications carried on power lines in the 150 to 250 kHz region. The filters may suppress carrier current such as that used for infant monitors and medical alert systems. Verify that suppressed carrier current or other desirable communications on power lines creates no hazard to people or property. Failure to observe this warning could result in damage to property, and injury or death for personnel.

⚠ WARNING:

All filter installation and wiring must be performed by qualified personnel, and conform to local and national electrical codes. Failure to observe this warning could result in damage to property, and injury or death for personnel.

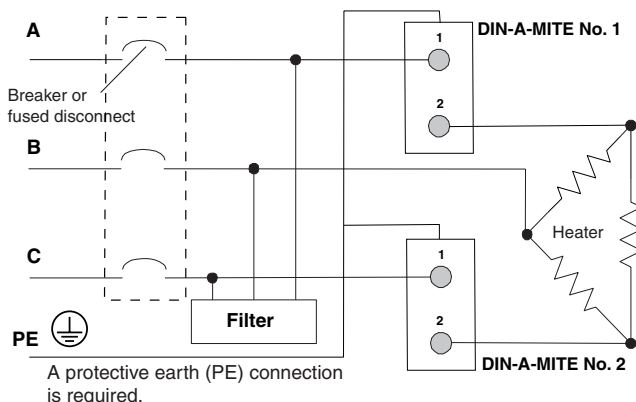

Figure 2 — Three-phase, 2-leg control using two (2) DIN-A-MITE D controllers. Contactor input models (C and K) only.

Returns

- Call or fax your distributor or the nearest Watlow sales office for best information about returns.
- To return directly to Watlow Winona in the U.S., first call or fax Customer Service for a Return Material Authorization (RMA) number telephone: +1 (507) 454-5300; fax: +1 (507) 452-4507.
- Put the RMA number on the shipping label, along with a written description of the problem.
- A restocking charge of 20% of the net price is charged for all standard units returned to stock.

Technical Assistance

If you encounter a problem with your Watlow controller, review your configuration information to verify that your selections are consistent with your application: inputs; outputs; alarms; limits; etc. If the problem persists after checking the configuration of the controller, you can get technical assistance from your local Watlow representative, or in the U.S., dial +1 (507) 454-5300. For technical support, ask for an Applications Engineer.

Please have the following information available when calling:

- Complete model number
- All configuration information
- User's Manual

The DIN-A-MITE Style D User's Manual is copyrighted by Watlow, Inc., © September 2004, with all rights reserved.

Warranty

The Watlow DIN-A-MITE is warranted to be free of defects in material and workmanship for 36 months after delivery to the first purchaser for use, providing that the units have not been misapplied. Since Watlow has no control over their use, and sometimes misuse, we cannot guarantee against failure. Watlow's obligations hereunder, at Watlow's option, are limited to replacement, repair or refund of purchase price, and parts which upon examination prove to be defective within the warranty period specified. This warranty does not apply to damage resulting from transportation, alteration, misuse, or abuse.