

# TRICITY BENDIX

UF400

**FREEZER**

FIG

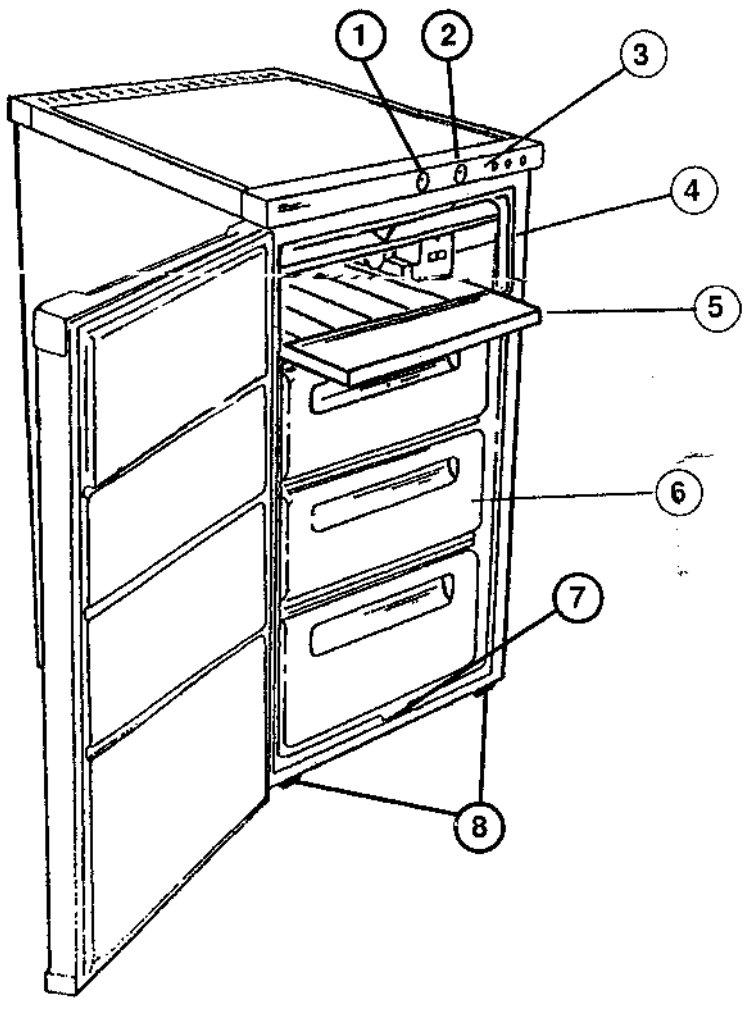

A

FIG



FIG

FIG 10

1. THERMOSTAT DIAL

2. FAST FREEZE CONTROL

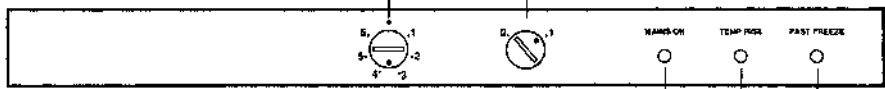

3. CONTROL INDICATOR LIGHT

4. RED INDICATOR LIGHT

5. AMBER INDICATOR LIGHT

FIG

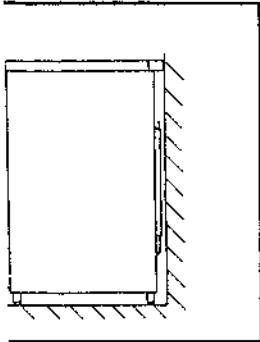

FIG 2

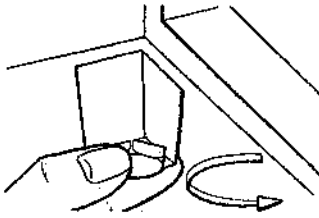

FIG 3

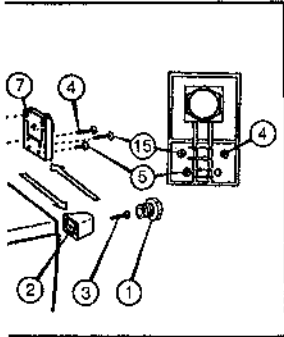
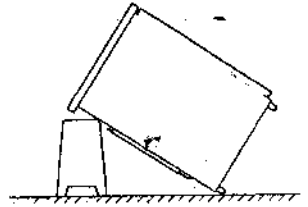

FIG 5

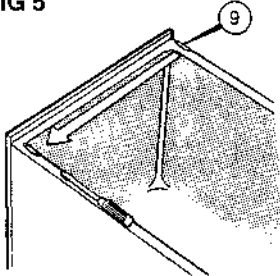

FIG 6

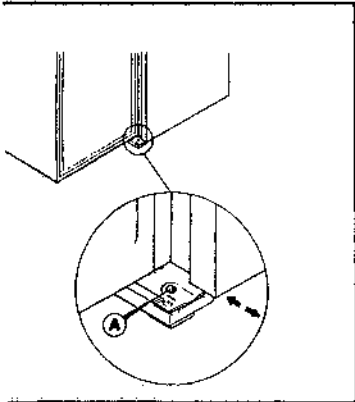
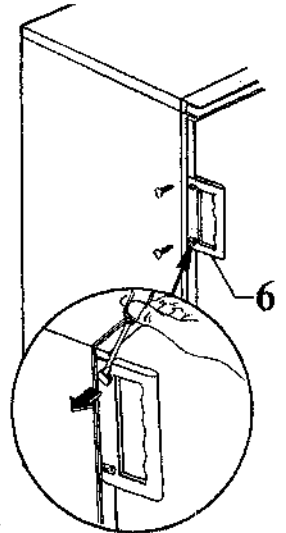

FIG 8 NON-FUSED PLUG  
GREEN & YELLOW

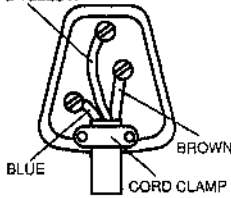

FIG 9 FUSED PLUG  
GREEN & YELLOW 13 AMP FUSE

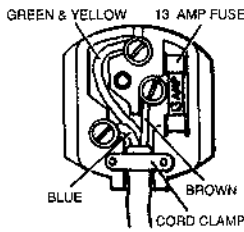
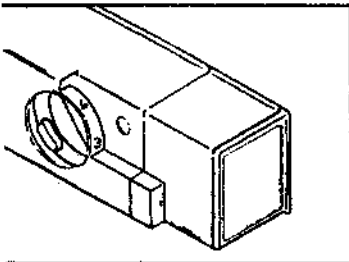
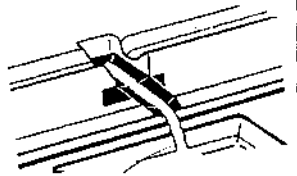

FIG 12



# WARNINGS



**IMPORTANT - PLEASE READ THIS INSTRUCTION BOOK BEFORE USING THE APPLIANCE**

**It is most important that this instruction book should be retained with the appliance for future reference. Should the appliance be sold or transferred to another owner, or should you move house and leave the appliance, always ensure that the instruction book is supplied with the appliance in order that the new owner can get to know the functioning of the appliance and the relevant warnings.**

**These warnings are provided in the interest of safety. You MUST read them carefully before installing or using the appliance.**

- This product is designed to be operated by adults. Children should not be allowed to tamper with the controls or play with the product.
- Any electrical work required to install this appliance should be carried out by a qualified electrician or competent person.
- This product should be serviced by an authorised Service Centre and only genuine spare parts should be used.
- It is dangerous to alter the specifications or modify the product in any way.
- Care must be taken to ensure that the appliance does not stand on the electrical supply cable.
- Domestic fridge/freezers are designed to be used specifically for the storage of edible foodstuffs only.
- There are working parts in this product which heat up. Always ensure that there is adequate ventilation as a failure to do this will result in possible food loss. See Installation instructions.
- Parts which heat up should not be exposed. Wherever possible, the back of the appliance should be close to a wall but leaving the required distance for ventilation as stated in the installation instructions.
- Before defrosting, cleaning or maintenance work is carried out, be sure to switch off the appliance and unplug it.
- Frozen food must NOT be refrozen once it has thawed out.
- Do not place carbonated or fizzy drinks in the freezer as it creates pressure on the container which may cause it to explode, resulting in damage to the appliance.
- The cooling plate or refrigerated freezer shelves in this appliance contain channels through which the refrigerant passes. If these are punctured this would cause substantial damage to the appliance and result in food loss. **DO NOT USE SHARP INSTRUMENTS** to scrape off frost or ice. Under **NO** circumstances should solid ice be forced off the lining or shelves. Solid ice should be allowed to thaw when defrosting the appliance. See Defrost instructions.
- The appliance should be left for 2 hours after installation before it is turned on, in order to allow the refrigerant to settle.
- This appliance is heavy. Care should be taken when moving it.
- Do not remove items from the freezer compartment if your hands are damp/wet, as this could cause skin abrasions or 'frost/freezer burns'.
- Ice lollies can cause 'frost/freezer burns' if consumed straight from the freezer.
- Manufacturer's food storage recommendations should be strictly adhered to. Refer to relevant instructions.
- Under no circumstances should you attempt to repair the appliance yourself. Repairs carried out by inexperienced persons may cause injury or serious malfunctioning. Refer to your local Service Centre and always insist on genuine spare parts.
- Occasionally during the operation the outside front edges of the appliance may feel quite warm to touch, this is normal.

## **CONTENTS**

INSTALLATION .....	<b>PAGE 3</b>
DOOR REVERSAL .....	<b>PAGE 3</b>
ADJUSTMENT OF DOOR .....	<b>PAGE 4</b>
ELECTRICAL CONNECTIONS .....	<b>PAGE 4</b>
THE CONTROLS .....	<b>PAGE 5</b>
USING YOUR MACHINE .....	<b>PAGE 5</b>
USING THE FAST FREEZE .....	<b>PAGE 6</b>
FROZEN FOOD STORAGE .....	<b>PAGE 6</b>
FOOD FREEZE GUIDE .....	<b>PAGE 7</b>
HEALTH AND SAFETY GUIDELINES .....	<b>PAGE 10</b>
CLEANING AND CARE .....	<b>PAGE 10</b>
WHAT HAPPENS IF SOMETHING GOES WRONG? .....	<b>PAGE 11</b>
SERVICE CENTRES .....	<b>PAGE 12-13</b>

## **GENERAL FEATURES** (SEE ILLUSTRATION A)

1. THERMOSTAT CONTROL (500mm WIDE MODELS ONLY)
2. FAST FREEZE CONTROL (500mm WIDE MODELS ONLY)
3. WARNING LIGHTS (500mm WIDE MODELS ONLY)
4. THERMOSTAT CONTROL (450mm WIDE MODELS ONLY)
5. FAST FREEZE FLAP
6. FREEZER BASKET
7. DRAIN CHANNEL
8. LEVEL ADJUSTERS

## INSTALLATION

**1.** This appliance is designed to operate in ambient temperatures between 10°C (50°F) and 32°C (90°F). It should be located in a dry atmosphere, out of direct sunlight and away from extreme temperature e.g. not next to a cooker or other sources of direct heat, or in a very cold room e.g. an outhouse, where the temperatures may fall below 10°C (50°F).

**2.** The appliance should be gently pushed into place until the table top rear ventilation grill touches the wall, see Fig 1.

When in position a 20mm (3/4") clear space above the appliance should be maintained. If a clear space of 20mm (3/4") above the appliance is not available clearances of 25mm (1") should be maintained on both sides of the appliance, this is to provide sufficient air circulation. Always ensure that the ventilation is kept clear from blockage by teatowels etc., because this will cause the appliance to work incorrectly.

## DOOR REVERSAL

**1.** If your appliance is already in use, disconnect it from the electricity supply and remove shelves and other loose items, including food. Place frozen food in boxes wrapped in blankets or other suitable insulating material and put in a cool place.

**2.** Gently lay the appliance on its back with the top held away from the floor by at least 30cm (12"), use a stool or something similar. Make sure to use a towel or cloth at the base to protect the sides of the appliance ensuring that it does not slip. Do not support the appliance on the rear ventilation grill, see Fig. 3.

**3.** Remove level adjuster (1) from the small foot assembly. The small foot (2) can now be removed by removing screw (3). In order to remove the large foot/hinge assembly (7) screws (4, 5 & 15) should be removed making sure that spacer (6) is retained with the assembly, see Fig. 4.

Carefully disengage the door from the upper hinge pin (See Fig. 5).

Unscrew the upper hinge pin (9) and transfer it to the opposite side (See Fig. 5).

**4.** Refit the door, engaging the top with the upper hinge pin in its new position.

**5.** Pull out the lower hinge pin (8) which may have come away with the hinge blade or remained in the door. Push the pin (rounded end) into the bush at the bottom of the door on the side opposite to its original position.

**3.** Your appliance will be heavy when loaded with food and must therefore be stood on a strong firm floor which should also be level. Adjust the level by screwing out the appropriate level adjusters in the feet using your fingers or a suitable spanner (see fig. 2).

Make sure the appliance is upright and all adjusters are in firm contact with the floor, so that the cabinet doesn't rock in any direction.

**4.** Before switching on, make sure that the voltage of your electricity supply is the same as that indicated on the rating plate. This is located inside the cabinet behind the salad drawer.

**5.** Remove **ALL** the foam blocks from the front of each basket, by pinching the block at its base and peeling back. These must be removed **before** operating the appliance.

**6.** Taking care not to press down on the door. The large foot/hinge assembly should be transferred over to the opposite side of the cabinet and screws, 15, 4 and 5 moved over to their new positions in the hinge foot.

**7.** It is important that the spacer (6) is retained with screw (4) in the channel between the base of the appliance and the foot/hinge when screwing the assembly into its new position.

**8.** Refit the small foot, positioning the screw in the hole furthest from the cabinet front on the flat portion of the base.

**9.** Replace the level adjuster (1) in the small foot.

**10.** Stand the appliance upright.

**11.** If your appliance has a side fix handle, see Fig 6.

i) Protect the paintwork from damage with masking tape or other suitable material between the blade and painted surface, while using a blunt knife or similar instrument to carefully prise out the plastic plugs from alternative handle positions on the opposite side of the door.

ii) Transfer the handle to its new position and push the plastic plugs into the vacated screw holes.

**12.** Finally level the appliance by means of the level adjusters (1) in the feet.

## ADJUSTMENT OF THE DOOR

Before carrying out the following instruction you must ensure that the appliance is DISCONNECTED from the electricity supply.

Occasionally door adjustment may be necessary i.e. if a slight clearance is noticeable between the door gasket and cabinet. This condition is mainly due to uneven floors or the loading of the door. It is possible to adjust the door at the hinge point (Fig. 7) as follows:

1. With the appliance standing on a level surface, check that the door opens and closes properly and seals all round.

2. If adjustment of the door is necessary this can be done by loosening the screw (A) securing the hinge blade to the foot and, adjusting the hinge blade and door in and out, a little at a time, to tighten or loosen the fit. Re-tighten the screw each time an adjustment has been made before again checking for satisfactory door closure.

## ELECTRICAL CONNECTIONS

**WARNING: THIS APPLIANCE MUST BE EARTHED.**

The manufacturer declines any liability should this safety measure not be observed.

### ELECTRICAL REQUIREMENTS

Before switching on, make sure that the voltage of your electricity supply is the same as that indicated on the rating plate, located inside the cabinet.

### WARNING! THIS APPLIANCE MUST BE EARTHED

For your convenience, this appliance comes complete with either a moulded-on or re-wireable 13 amp (BS1363) plug, protected by a 13 amp ASTA approved (BS1362) fuse.

In the event of having to change the fuse in the plug supplied, a replacement 13 amp ASTA approved (BS1362) fuse must be used.

In the case of a moulded-on plug, the fuse cover MUST be refitted after changing the fuse. If the fuse cover is lost or damaged the plug MUST NOT be used until a replacement is obtained.

Replacement covers are available from your local electricity shop or nearest customer service centre. The colour of the replacement fuse cover must match the colour insert or emboss on the base of the plug.

In the case of a re-wireable plug, care must be taken to ensure that the top cover is refitted without causing damage to either the top cover or base. In the event of the plug becoming damaged or cracked, it must be replaced with an equivalent 13 amp, BS1363 approved plug (ref. fig.9) and rewired using the following procedure:-

### IMPORTANT

The wires in the mains lead are coloured in accordance with the following code:

GREEN & YELLOW : EARTH  
BLUE : NEUTRAL  
BROWN : LIVE

The wire coloured green and yellow must be connected to the terminal marked with the letter "E" or by the Earth Symbol  or coloured green or green and yellow. The wire coloured Blue must be connected to the terminal marked with the letter "N" or coloured black. The wire coloured Brown must be connected to the terminal marked "L" or coloured red.

Upon completion there must be no cut, loose or stray strands of wire present and the cord clamp must be secure over the outer sheath.

If a 13 amp (BS1363) plug is unsuitable for your sockets, the plug should be removed, (cut-off in the case of a moulded-on plug) and an appropriate plug fitted.

**NOTE: Moulded plugs cannot be re-used and should be discarded if cut from a mains lead, as insertion into a 13 A socket could prove fatal.**

If a non-fused plug is fitted (ref. fig.8), the wiring must follow the above procedure and the appliance must be protected by the use of a 15amp fuse either in the adaptor or at the distribution board.

If at any time a replacement supply cord is required, the cross sectional area of its conductors must not be less than 0.75mm<sup>2</sup> and the cable clamp must be tightened so as to fully retain the new cord.

We recommend that this type of installation be checked by a fully qualified electrician, prior to use.

# THE CONTROLS

## 500MM WIDE MODELS:

On 500mm wide models you have the following controls; (where fitted) which are in the table top, see fig.10.

### 1. THERMOSTAT DIAL

The thermostat dial operates the fridge compartment. With the aid of a coin turn the thermostat dial clockwise to align the Black Indicator with the required temperature setting.

### 2. FAST FREEZE CONTROL

By turning the fast freeze control dial (with the aid of a coin) clockwise to 'I' the fast freeze mode begins, it is indicated by the amber light (5) illuminating. When you turn the dial back to 'O' the amber light will go out and the appliance will return to normal running.

### 3. GREEN INDICATOR LIGHT

When the appliance is switched on at the mains, the green indicator light will illuminate showing that the appliance is switched on. The light will go out if the appliance is switched off.

### 4. RED INDICATOR LIGHT

The red indicator light is the temperature warning light, it will illuminate when the electricity supply is first switched on or when the freezer temperature rises above the required storage temperature. The light will go out when the temperature falls to the correct storage level.

### 5. AMBER INDICATOR LIGHT

The amber indicator light is incorporated with the Fast Freeze switch (2), which overrides the thermostat when switched on. This allows the freezer to run continuously. The light will remain illuminated until the Fast Freeze is turned off.

## 450MM WIDE MODELS:

On 450mm wide models you only have a thermostat control which is situated inside the cabinet, see fig. 11.

# USING YOUR MACHINE

## BEFORE USING

Remove all securing tapes. Wash the inside of the appliance with lukewarm water with a little bicarbonate of soda added (5ml to 0.5 litre of water). Do not use soap or detergent as the smell might linger. Dry the appliance thoroughly.

## FREEZER COMPARTMENT

The  symbol means that your freezer will store frozen food at -18°C (-0.4°F) or colder for long term storage and will also freeze fresh food.

If frozen correctly, food will retain texture, colour, taste and nutritional content.

The interior temperature of the freezer is automatically controlled by the thermostat. The freezer is designed to produce a storage temperature of -18°C (-0.4°F) or colder. This will normally be achieved with a setting of 4 on the control dial. The control dial is numbered 1-6. The higher the number the colder the temperature. On setting '1' the cooling system is switched off, but the appliance is not disconnected from the electricity supply.

Due to different installations, methods of usage and weather conditions, adjustments to the temperature setting may be required. These are best assessed against a temperature reading on a thermometer buried in the frozen food or in a block

of margarine or butter. Remember you must take your reading very quickly since the thermometer temperature will rise rapidly after you remove it.

If colder settings are selected for extra chilling effect, do not forget to turn the control dial back to the correct setting afterwards.

## FREEZING FRESH FOODS

The refrigerated top shelf in the appliance should be used as a fast freeze compartment. Any existing frozen food should be rearranged to leave space on the top shelf for freezing.

- \* The Maximum quantity of fresh food you can freeze in any 24 hours is 8.5kg for 450mm and 8.0kg for 500mm wide models.

Most fresh food will freeze well, however some freeze more successfully than others. Food with a low proportion of water such as bread, cakes, pastry, meat, fish and poultry freeze exceptionally well. Similarly, game, dairy produce, fruit and vegetables all keep well in the freezer.

Food with a high water content such as lettuce and marrow do not freeze well as the freezing process breaks down their cellular structure. Other items which do not freeze well are mayonnaise because it separates, bananas because they turn black and whole eggs in their shells because they crack.



## USING THE FAST FREEZE

### **CONTROL 500mm WIDE MODELS ONLY**

On this model when freezing fresh food the Fast Freeze switch (see fig.10) should be switched from the normal operating position '0' to '1' and run the appliance for at least 24 hours before placing food inside. The amber fast freeze light will indicate that the freezer is in the fast freeze mode. This will lower the temperature inside the freezer.

Place the fresh food on the top shelf in contact with the refrigerated surface leaving a space between

items to allow cold air to circulate. After 24 hours the food will be fully frozen and can be transferred to one of the baskets. The fast freeze switch can now be returned to its normal operating position '0'.

### **NOTE**

After starting up or cleaning of the appliance the fast freeze procedure should not be carried out until the red light goes out and the freezer is at its normal operating temperature.

## FROZEN FOOD STORAGE

Your appliance has the following net storage volume:

450mm wide model: Net storage volume 70.22 litres (2.48 cuft)\* weight of stored food 22.5kg (49.6lb.).

500mm wide model: Net storage volume 75.81 litres (2.68 cuft)\* weight of stored food 24.3kg (53.57lb.).

\*This is a standard measurement and the actual capacity depends upon the density and sizes of the food. The above figures are based on an average density of 0.32Kg per litre (20lb per cuft).

Pre packed frozen food should be put in the freezer as soon as possible after purchase.

Your freezer provides for long term storage which generally means up to 3 months, but the length of time can vary and it is important to follow the recommended times shown on packets of commercially frozen food.

Any opened packets of frozen food, should be rewrapped in airtight materials to prevent surface evaporation which causes drying or 'freezer burn'.

### **IMPORTANT**

If the temperature rises in frozen food because of:

- Non compliance with manufacturer's recommendations.
- Electric power failure.
- Due to defrosting.

Then recommended storage life may be reduced and storage times may not apply.

Frozen food which is allowed to thaw accidentally should either be used immediately or thrown away. Alternatively if the food is uncooked and has not been completely defrosted it can be cooked and then refrozen.

### **NOTE**

- Do not place sealed containers of carbonated liquids such as fizzy drinks into the freezer as it creates pressure on the container which may cause it to explode resulting in damage to the freezer.
- Ice cubes and ice lollies should not be consumed immediately after removal from the freezer as it may result in low temperature skin abrasions.

### **NOTE**

Aim to check dates on packets and rotate food regularly. Although storage longer than recommended is not harmful, flavours and textures begin to deteriorate.

# FOOD FREEZING GUIDE

	<i>Max. Storage Period</i>	<i>Method</i>	<i>Remarks</i>
<b>MEAT Joints</b>			
Beef	10-12 months	Remove additional fat. Cut to handy size, wrap thoroughly.	Pad bone ends.
Pork	6 months	Cut to hand size, wrap thoroughly.	ditto
Lamb	9 months	ditto	ditto
Steak	10-12 months	Open freeze or interleave with plastic film.	ditto
Chops	See Pork or lamb above	ditto	ditto
Veal Fillets	6-9 months	ditto	
Bacon, cured	6 weeks	ditto	Pack in handy meal portions.
smoked	1 month		
Sausages	6 weeks	Wrap tightly.	Pack in handy meal portions.
Minced meat	2 months	Wrap tightly.	Pack in handy meal portions.
Offal and tripe	3 months	Clean thoroughly, remove tubes, cores and fat, pack in small portions.	Make sure it is really fresh.
<b>POULTRY</b>			
Chicken	9-12 months	Clean in usual way, joint if necessary, wrap thoroughly.	Wrap giblets separately, pad bone ends. Do not stuff till ready.
Turkey	9-12 months	Clean in usual way, joint if necessary.	ditto
Duck, Goose	6 months	Clean in usual way, joint if necessary.	ditto
Giblets	3 months		Wrap separately from bird.
Game	6 months	Hang before freezing.	Cook immediately after thawing.
<b>FISH</b>			
All types	3 months	Clean, descale, discard head and tail, wrap separately.	Must be fresh.
Trout	3 months	Clean, descale, discard head and tail, wrap separately.	Must be fresh.
Salmon	3 months	Clean, stuff with greaseproof paper for shape retention or cut into steaks, cutlets or fillets.	Must be fresh.
<b>VEGETABLES</b>			
Mushrooms	3 months	Leave button mushroom whole, slice larger ones. Trim stalks, wash, dry thoroughly. Freeze open (or sautéed in a little butter till partially cooked then freeze).	Pack in boxes.
Potatoes	3 months	New potatoes and chips can be frozen raw. Otherwise cook partially in one of usual forms, cool then freeze.	
Beans (Broad, French or runner)	12 months	Peel or pod and wash, top and tail. Cut large beans into shorter lengths or slice.	Blanch for 2 mins., cool for same time in iced water then freeze.

	<b>Max. Storage Period</b>	<b>Method</b>	<b>Remarks</b>
Carrots	12 months	Use small ones. Prepare by scraping top and tail.	Blanch for 3-4 mins.
Cauliflower	12 months	Break up the florets and wash.	Blanch for 3mins. Add lemon juice to water to improve whiteness.
Spinach	12 months	Wash thoroughly. remove thicker veins. Chop if liked.	Blanch a few leaves at a time, for 2 mins.
Sprouts	12 months	Use only small ones. Remove outer leaves.	Blanch for 3mins, - medium 1½ mins, - small.
Root crops	12 months	The younger the better. Peel and slice or freeze whole.	Blanch for 3-5 mins.

#### FRUIT

Apples	9-12 months	Freeze either of two ways: as puree-stew with little water, beat to smooth pulp, sweeten to taste, blanch for two mins., drain and cool. Pack tightly in layers with a little dry sugar sprinkled between, if so desired; or soak in slightly salted water for ten minutes, dry and freeze.	Freeze in small quantities Pack in plastic containers, leaving 1.5cm (½ in.) headroom
Apricots	10-12 months	Preferably remove stones, but leave skins on. Pack in syrup 200-400g (½-1lb.) sugar to 550ml (1 pint) of water, making sure fruit is covered.	Pack in plastic containers leaving 1.25-2.5cm (½-1in.) headroom
Cherries	12 months	ditto	ditto
Damsons	12 months	ditto	ditto
Plums	9 months	ditto	ditto
Gooseberries	12 months	ditto	ditto
Blackberries	12 months	Either pack in syrup as above, or coat with caster sugar and pack in plastic containers. Also may be frozen open then pack in containers.	ditto
Currants	12 months	ditto	ditto
Raspberries	12 months	ditto	ditto
Strawberries	12 months	ditto	ditto
Peaches	10 months	Cover with boiling water for 1 minute then cool by dipping into cold and peel carefully. Cut into halves, removing stone. Use syrup method of packing and freezing.	keep fruit submerged in syrup, place crumpled greaseproof paper on top, so there is no room between the surface of the liquid and the lid.

#### DAIRY PRODUCTS

Eggs whole	6 months	Pack leaving headspace, beat slightly.	Do not freeze eggs in their shells as they will crack.
------------	----------	--	--

	<b>Max. Storage Period</b>	<b>Method</b>	<b>Remarks</b>
Egg Whites	6 months	Beat slightly, place whites in small containers just a few at a time.	
Egg Yolks	6 months	As for whites, but to prevent coagulation mix with ¼ tsp. salt or ½ tsp. caster sugar to every two yolks.	Use for savoury or sweet dishes, label so that correct yolks are used.
Butter	6 months (unsalted) 3 months (salted)	Wrap bought butter in foil and freeze.	
Cream Whipping and Double only	3 months	Must first be beaten slightly before freezing. Rosettes of whipped cream can be piped onto silicone paper and open frozen.	Allow slight room for expansion in the container. Pack in layers.
Cheese	4 months (soft) 3-4 months (hard)	Wrap all varieties tightly in foil.	Hard cheese stores much better when grated.

#### **BAKED ITEMS Wrap in foil or polythene bags**

Bread (Freshly baked)	1-2 months	Wrap and freeze.
Cakes, plain	6 months	Wrap and freeze.
Cakes, iced	3 months	Freeze without wrapping, then wrap and store in polythene.

#### **PREPARED FOODS**

Stews	2 months	May be frozen quite satisfactorily in a polythene bag.	Place bag inside a square plastic or cardboard box to shape the contents into bricks which save space in freezer.
Sauces	4 months	Freeze in quantities of 275ml (½ pint) A little extra liquid may be required, when you come to use it.	Egg based sauces are unsuitable.
Full courses	3 months	Assemble individual helpings on specially constructed aluminium trays, then cover with foil. To re-heat leave the cover on and put in the oven for about 45 minutes at 200°C/Mark 6.	Cover slices of meat with gravy to prevent drying out.

## HEALTH AND SAFETY GUIDELINES

*Because of consumer demand, preservatives have been removed from many pre-prepared food. This together with the changes in shopping habits to a once a-week shop, mean that safe handling and storage of food is even more important than ever.*

*The following tips should help you to ensure that the food in your home is in as perfect condition as possible.*

- Keep the time between buying chilled food and placing it in your fridge as short as possible. Tests showed that the temperature of 1 litre of orange juice rose to 22°C in an hour between the supermarket and home. It then took 11 hours to get down to 7°C in the refrigerator.
- Keep the freezer door closed as much as possible. Remember that warm air is flowing in as you are deciding what to have for tea!
- Do not push food together too much, try to allow air to circulate around each item.
- Cool cooked food as quickly as possible but do NOT place in the refrigerator or freezer until cool. (Leave food in a place as cool as possible in order that it can then be placed in the refrigerator or freezer as soon as possible).
- Do NOT mix raw and cooked meat, they must be in separate containers. Take care not to let the meat juices drip onto other food. If the meat does drip, remove everything and clean thoroughly.
- Do not store food uncovered.
- The best way to defrost food is to put it in the refrigerator to thaw slowly.
- Remove suspect food from your refrigerator and clean the interior with a solution of bicarbonate of soda in warm water (5ml to 0.5 litre of water).
- Never allow spillages to dry and harden.
- Ensure that food placed in the freezer is dated and labelled and used in date order to ensure that food is consumed at its best.
- It is important that food is used before its 'best before' date.
- Regularly check the freezer door seal to ensure that it is clean and free from bits and pieces.
- Always wash your hands with soapy water and dry them with a clean towel before handling food.
- Keep work surfaces clean and avoid cross contamination by not using the same work surface or knife, without washing them thoroughly in between.
- Use kitchen roll wherever possible for cleaning up food. If you use a dishcloth, be sure to boil it frequently.

## CLEANING AND CARE

**BEFORE any maintenance or cleaning work is carried out, DISCONNECT the appliance from the ELECTRICITY supply.**

### INTERNAL CLEANING

Clean the inside and accessories with warm water and bicarbonate of soda (5ml to 0.5 litre of water). Rinse and dry thoroughly.

**NEVER USE DETERGENTS, ABRASIVE POWDERS, HIGHLY PERFUMED CLEANING PRODUCTS OR WAX POLISHES, TO CLEAN THE INTERIOR AS THESE WILL DAMAGE THE SURFACE AND LEAVE A STRONG SMELL.**

### EXTERNAL CLEANING

Wash the outer cabinet with warm soapy water. Do NOT use abrasive products. Please Note: There are sharp edges on the underside of the product so care should be taken when cleaning.

Once or twice a year dust the condenser (black grille) and the compressor at the back of the appliance, with a brush or vacuum cleaner.

You MUST ensure that the appliance is switched OFF. An accumulation of dust will affect the

performance of the appliance and cause excessive electricity consumption.

### WHEN THE APPLIANCE IS NOT IN USE

When the appliance is not in use for long periods, disconnect from the electricity supply, empty all food and clean the appliance, leaving the doors ajar to prevent unpleasant smells.

In the freezer compartment, frost accumulates on the shelves during normal working and should occasionally be removed with the plastic scraper provided.

Heavy frosting (1/4" thick) will reduce the freezers efficiency and therefore complete defrosting should then be carried out, probably at 6 month intervals depending on usage.

Preferably you should defrost the freezer when there is little or no food in it.

1. Any remaining frozen food should be placed in another freezer, or wrapped in blankets, or layers

of paper and placed in cardboard boxes, and then stored in a cool place.

2. Switch off the wall socket and remove the plug.
3. Fold out the defrost flip spout and place a suitable container under the spout to collect the defrost water, you must leave the door open, see Fig. 12.
4. Defrosting can be speeded up by putting bowls of hot (not boiling) water in the freezer and loosening the frost with a stiff bristle brush or suitable plastic scraper.

5. After defrosting, clean and dry the interior, then fold up the flip spout. Switch the appliance back on and replace any frozen food and close the door.

**REMEMBER**, If the temperature of frozen food is allowed to rise during the defrosting period, its storage life may be shortened.

## WHAT HAPPENS IF SOMETHING GOES WRONG?

**BEFORE** contacting your local Service Force Centre, check the following points:

**The appliance does not work . . . Check that:**

- \* There is power at the socket.
- \* Ensure that there is not a power cut by checking the household lights.
- \* The fuse has not blown.
- \* The air circulation passages are not covered.

**Vibration or abnormal noises . . .**

- \* You may hear faint gurgling or bubbling sounds when the refrigerant is pumped through the coils of tubing at the rear, to the cooling plate/evaporator or to the fixed freezer shelves. When the compressor is on, the refrigerant is being pumped round, and you will hear a whirring or pulsating noise from the compressor. A thermostat controls the compressor, and you will hear a faint 'click' when the thermostat cuts in and out.

**The light does not come on . . . Check that:**

- \* The bulb is fitted correctly.
- \* Replace the bulb if it has blown.

**Other points to check . . . Check that:**

- \* Have you turned the thermostat to the correct setting?
- \* Have doors been left open causing the temperature to rise?
- \* Sometimes the freezer door will be difficult to open shortly after you have closed it. Don't worry this is due to pressure difference which will quickly equalise and allow the door to open normally.

If after the above checks, there is still a fault, call your local Service Centre.

**In-guarantee customers should ensure that the above checks have been made as the engineer will make a charge if the fault is not a mechanical or electrical breakdown.**

- \* Please note that proof of purchase is required for any In-guarantee service calls.

Before contacting your local Service Centre, make a note of the make, model and date of purchase of your machine: the Service Department require this information. See pages 12-13 for your nearest Service Centre.

**In the event of a power failure causing the temperature within your freezer to rise do not re-freeze the food without checking its condition. The following guidelines should assist you.**

Ice Cream: Once thawed should be discarded.

Fruit & Vegetables: If soft should be cooked and used up.

Bread & Cakes: Can be re-frozen without danger.

Shellfish: Should be refrigerated and used up quickly.

Cooked Dishes: ie casseroles should be refrigerated and used up.

Large Pieces of Meat: Can be re-frozen providing there are still ice crystals remaining within them.

Small Joints: Should be cooked and can then be re-frozen as cooked dishes.

Chicken: Should also be cooked and re-frozen as a cooked dish.

# TRICITY BENDIX SERVICE CENTRES

<b>ABERDEEN</b>	AB 0224 698569	Electrolux After Sales Service, Northeast Appliance Service, 8 Cornhill Arcade, Cornhill Drive, Aberdeen AB2 5UT
<b>ARGYLE</b>	PA24-61 0505 321316	Electrolux After Sales Service, T.D.C. Refrigeration, 40 Arran Place, Linwood, Renfrewshire PA3 9QU
<b>BARNSTAPLE</b>	EX18-23 0271 328826 31-39	Electrolux After Sales Service, Mc Bain Refrigeration, Unit 4, Uppcott Avenue, Pottington Industrial Estate, Barnstaple, N. Devon EX1 1HN
<b>BORDERS</b>	TD 0573 224411	Electrolux After Sales Service, James Stewart & Son, 2-8 Wood Market, Kelso, Borders TD5 7AX
<b>BOURNE</b>	PE1-15 0778 394424 PE24,38 NG31-34	Electrolux After Sales Service, Bourne Electrical, Pinfold Road, Manning Road Industrial Estate, Bourne, Lincolnshire PE10 9HT
<b>CANVEY</b>	EEO SN N NW W WC 081 443 3463 AL C8 HA LU MK SG 061 965 9699 UB WD 061 965 9699 IP MR CM CO IG RM SS 0269 964144 PE16-19, 30-33, 35-37 0269 964144	Electrolux After Sales Service, 2-4 Sandhurst, Kings Road, Canvey Island SS8 0QY
<b>CARDIFF</b>	CF NP1-4, 6, 9-44 0222 460131 SA1-18 SA21-32	Electrolux After Sales Service, Guardian Industrial Estate, Clydesmuir Road, Tremorfa, Cardiff CF2 2QS
<b>CUMBRIA</b>	CA 0288 594747	Electrolux After Sales Service, ETB Services, Carlisle Enterprise Centre, James Street, Carlisle CA2 5AP
<b>DUMFRIES &amp; GALLOWAY</b>	DG1-14 0887 85166	Electrolux After Sales Service, Alan Crossan (service), 93 Irish Street, Dumfries Scotland
<b>DUNDEE</b>	DD1-14 0250 876285 PHB-18	Electrolux After Sales Service, 1 Brogan Domestic, 1 Lochinblair Gardens, Dunkeld Road, Blairgowrie, Perthshire PH10 6GA
<b>FIFE</b>	KY1-16 0592 610590 PH1-7	Electrolux After Sales Service, M & H Appliances, 8 Eddison House, Fullerton Road, Queensway Industrial Estate, Glenrothes, Fife KY7 5QR
<b>GLASGOW</b>	G KA ML PA1-23 041 647 4381 EH FK ZE	Electrolux After Sales Service, 20 Cunningham Road, Clyde Estate, Rutherglen, Glasgow G73 1PP
<b>GUERNSEY</b>	All Codes 0481 46931	Guernsey Electricity, PO Box 4, Vale Guernsey, Channel Island
<b>HAVERFORDWEST</b>	SA33-38 0437 710914 SA41-44 SA61-73	Electrolux After Sales Service, C Butherway, 1 Church Road, Roch, Haverfordwest, Dyfed SA62 6AG
<b>HEREFORD</b>	HR1-9 LD1-8 0432 340334 SY7,18 NPS NP7-8	Electrolux After Sales Service, Domestic Repair Centre, Unit 3 Bank Buildings, Cattle Market, Hereford HR4 9HX
<b>HULL</b>	YO4 YO11-18 0482 585678 YO25 HU1-19 DN14	Electrolux After Sales Service, John Sizer, Unit 1 Boulevard Unit, Factory Estate, Hull HU3 4AY
<b>INVERNESS</b>	IV1-28, 30-36 0463 792952 40-49 51-56 PH19-26 30-44 KW1-14	Electrolux After Sales Service, Highland Appliances, Unit 383 Smithton Industrial Estate, Smithton, Inverness
<b>ISLE OF WIGHT</b>	PO30-41 0983 872552	Electrolux After Sales Service, Wyratts Electrical Service, 4 Forelands Road, Bembridge, I O W, PO35 5XW
<b>JERSEY</b>	All Codes 0534 505050	Jersey Electricity Company PO Box 45 Queens Road, St Helier JE4 8NY Jersey, Channel Islands
<b>LAMPETER</b>	SA19,20 SA40 0570 423020 SA45-48 SY23-25	Electrolux After Sales Service, Lampeter Domestic Appliance Service, Unit 18 Lampeter Ind. Est., Lampeter SA48 7DY
<b>LANCASTER</b>	LA1-23 0772 316175	Electrolux After Sales Service, NL Services, Unit 33 Rangleit Rd., Walton Summit, Bamber Bridge, Preston, Lancs PR5 8AR
<b>LEEDS</b>	BD DN1-7, 10-12 0532 608511 HD HG HX LS S WF YO1-3 5-8 DE NG1-22 & 25	Electrolux After Sales Service, 64-66 Cross Gates Road, Leeds LS15 7NN
<b>LINCOLN</b>	DN21 Sub Codes 0522 514903 1,2 & 5 only LN1,2 4-6 LN3 sub codes 4,5 only LN8-10 NG23,24 PE20-25	Electrolux After Sales Service, Brian Hudson, Unit 8 Stonefield Park Clifton Street, Lincoln LN5 8AA
<b>NEWTON ABBOTT</b>	EX1-17 0626 65969 TQ PL1-9 16 19-21	Electrolux After Sales Service, South West Domestic Service, Unit 2 Zzalley Industrial Estate, Kingsteignton, Newton Abbott, South Devon TQ12 3SJ
<b>NORTH WALES</b>	LL 0745 591616	Electrolux After Sales Service, GMS (Cymru), Unit 2 Coed - Parc, Abergale Road, Rhuddlan, Clwyd LL18 5UG
<b>NORTHERN</b>	DLTSD:YD21,22 0325 301400 DH NE SR 091 493 2025 FY PR WN BB 0282 774621 BL M OL SK 0282 774621 CH CW L WA 051 2541724	Electrolux After Sales Service, PO Box 40, Preston Road Aycliffe Industrial Estate, Newton Aycliffe, Co. Durham DL5 6XA

# TRICITY BENDIX SERVICE CENTRES

<b>NORTHERN</b>	BT1-30, 38-57	0232 746591	Electrolux After Sales Service, Unit C3, Edenderry Ind. Est., 326, Crumlin Road, Belfast BT14 7EE
<b>IRELAND EAST</b>	63-67		
<b>NORTHERN</b>	BT31-35	0861 510400	Electrolux After Sales Service, G & Q (Armagh) Service, Owenmore House, Kilwee Business Park, Upper Dunmurray Lane, Belfast BT17 0HD
<b>IRELAND WEST</b>	60-62 68-82 92-94		
<b>MUNEATON</b>	B DY ST TF	021 358 7076	Electrolux After Sales Service, Unit 23-24 Alliance Business Park, Townsend Drive, Muneaton, Warwickshire CV11 6PX
	WR WS WV	021 358 5051	
	GL HP NN OX RG SL SN	0993 704411	
	CV LE	0209 354424	
<b>REDRUTH</b>	TR1-20 26 27	0209 314407	Electrolux After Sales Service, Cornwall Domestic Service, Unit 7D Pool Industrial Estate, Wilson Way, Redruth, Cornwall TR15 3QW
	PL10-15 17 18 22-35		
<b>SHREWSBURY</b>	SY1-6 SY8-17 SY19-22	0743 450279	Electrolux After Sales Service, BLI Service, 6 Harlescott Barn, Harlescott Lane, Shrewsbury, SY1 3SY
<b>SOUTH</b>	DN8,9 DN15-20	0472 267978	Electrolux After Sales Service, John Robinson (Electrical), Unit 74 New Enterprise Centre, King Edward Street, Gt. Grimsby DN31 3JP
<b>HUMBERSIDE</b>	DN21 DN31-40 LN (3 sub code 6 only) 7 LN11-13	Sub Codes 3,4 only	
<b>SOUTHERN</b>	BN16-18 BH DT SO SP BA BS PO1-22 TA TR21-25	0705 667411  0272 211876	Electrolux After Sales Service, Limberline Road, Hilssea, Portsmouth, Hampshire, PO3 5JJ
<b>TONBRIDGE</b>	CT DA ME GU1-26 TN BN1-15 RH TW BR CR SE SW SM KT	0732 357722  0273 694341 081 658 9069	Electrolux After Sales Service, 61-63 High Street, Tonbridge, Kent, TN9 1SD









# **GUARANTEE**

This guarantee is offered to you as an extra benefit and does not affect your legal rights.

Tricity Bendix products are carefully designed, manufactured, tested and inspected and in consequence we undertake to replace or repair any part found to be defective in material or workmanship, within one year of delivery to the original purchaser, free of charge.

The Company does not accept liability for defects arising from neglect, misuse, or accident. The interior lightbulb and glassware on refrigerators and larders are also excluded from the guarantee.

There are certain conditions which may invalidate this guarantee:

- a) It is dependent upon the appliance being correctly installed and used in accordance with the Company's instructions under normal domestic conditions within the United Kingdom or the Republic of Ireland.
- b) Service at all times must be carried out by a Tricity Bendix Representative or authorised agent.
- c) This guarantee may be invalidated by unauthorised repair or modification of the appliance.

Proof of the date of purchase will be required before service under guarantee is provided.  
Addresses or telephone numbers for service requests as listed.

We must point out that this guarantee does not cover liability for loss of food or other contents. attention to the insurance facilities described on the separate leaflet.