



Operators Manual

Installation, Operation & Service

Cook/Chill Direct Steam Mixer Kettles

MODELS: MKDL-40-CC
MKDL-60-CC
MKDL-80-CC
MKDL-100-CC
MKDL-125-CC
MKDL-150-CC

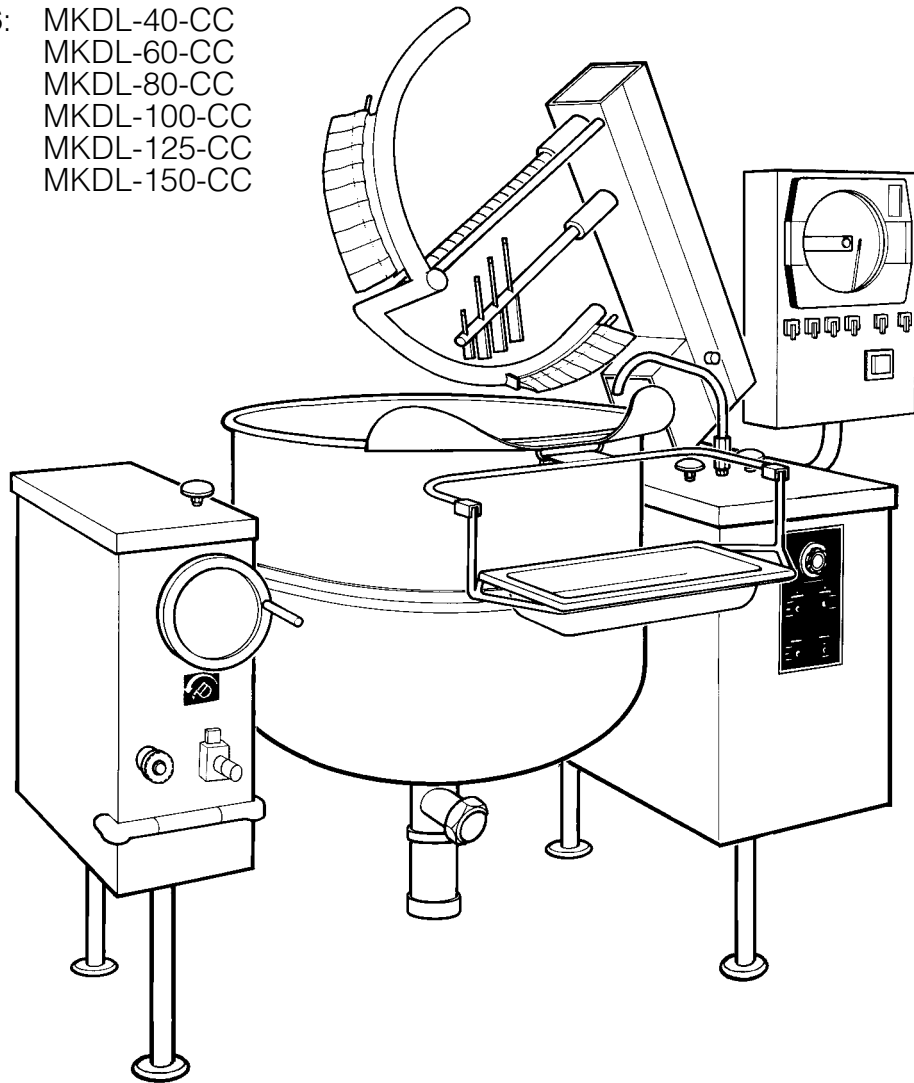

Enodis

1333 East 179th St., Cleveland, Ohio, U.S.A. 44110

Phone: (216) 481-4900 Fax: (216) 481-3782
Visit our web site at www.clevelandrange.com

TABLE OF CONTENTS

Installation	<i>General</i>	1
	<i>Inspection</i>	1
	<i>Shipping Damage Instructions</i>	1
	<i>Clearance Requirements</i>	1
	<i>Recommended Floor Drain Location</i>	1
	<i>Moving Unit</i>	2
	<i>Leveling</i>	2-3
	<i>Electrical Service Connections</i>	3
	<i>Compressed Air Connection</i>	3
	<i>Piping Connections</i>	3
	<i>Piping Schematic</i>	4
	<i>Steam Requirements for Kettles</i>	4
	<i>Steam Pipe Sizing</i>	4
	<i>Quality Assurance Checklist</i>	5-6
Operating Instructions	<i>Operating Controls & Indicators Drawing</i>	7
	<i>Operating Suggestions</i>	8
	<i>Safety</i>	8
	<i>General Operation</i>	8
	<i>Lifting & Lowering Bridge</i>	8
	<i>Mixing</i>	8
	<i>Tilting Kettle</i>	8
	<i>Discharge Valve</i>	9
	<i>Adding Water</i>	9
	<i>Water Meter</i>	9
	<i>Manual Heating/Cooling</i>	9
	<i>Automatic Heating/Cooling</i>	9
	<i>Mixer Kettle Operation using Cal 9900</i>	10
<i>Changing Functions & Operations</i>	10	
Cleaning Instructions	<i>Preproduction Sanitizing Procedure</i>	11
	<i>Sanitizing Solution Chart</i>	11
	<i>General</i>	11
	<i>Automatic Dump Valve</i>	12
	<i>Butterfly Valve</i>	12
	<i>Scraper Blades</i>	12
	<i>Sanitizing</i>	12

Service Parts

<i>Warranty</i>	13
<i>Lubricator</i>	13
<i>Filter</i>	13
<i>Remote Control Assembly</i>	14
<i>Main Console Controls</i>	15
<i>Switch Configuration</i>	16
<i>Hydraulic Components</i>	17-18
<i>Plumbing Assembly - 10" Console</i>	19
<i>Plumbing Assembly - 18" Console</i>	20
<i>Air System - 10" Console</i>	21
<i>Manual Tilt - 10" Console</i>	22
<i>Power Tilt - 10" Console</i>	23-24
<i>Water Meter Assembly - 18" Console</i>	25-26
<i>Electrical Component Assembly</i>	27
<i>Flush Piston Valve</i>	28
<i>Butterfly Valve</i>	29
<i>Main Component Reference Chart</i>	30

Maintenance

<i>Inspection and Maintenance Check List</i>	31
<i>MRC 7000 Enable Mode Procedure</i>	32
<i>Airline Lubricator Oil Filling Procedure</i>	33
<i>Air Filter Replacement Procedure</i>	33
<i>Automatic Dump Valve</i>	33
<i>Steam Trap</i>	33
<i>Re-Installing Speed Control Cable</i>	34
<i>Hydraulic Oil Replacement Procedure</i>	34
<i>Lubrication</i>	35
<i>Disassembly of Switch Assembly</i>	35
<i>Solenoid Valve Maintenance</i>	36-37
<i>Wiring Diagram</i>	38
<i>Flow Path for Hydraulic System</i>	39
<i>Spare Parts List</i>	40

INSTALLATION

GENERAL

Installation of the kettle must be accomplished by qualified installation personnel working to all applicable local and national codes. Improper installation of product could cause injury or damage.

This unit is built to comply with applicable standards for manufacturers. Included among those approval agencies are: UL, NSF, ASME/Ntl.Bd., CSA, ETL, CE, and others. Many local codes exist, and it is the responsibility of the owner/installer to comply with these codes.

INSPECTION

Before uncrating, visually inspect the unit for evidence of damage during shipping. If damage is noticed, do not unpack the unit, follow shipping damage instructions.

SHIPPING DAMAGE INSTRUCTIONS

If shipping damage to the unit is discovered or suspected, observe the following guidelines in preparing a shipping damage claim.

1. Write down a description of the damage or the reason for suspecting damage as soon as it is discovered. This will help in filling out the claim forms later. If possible, take a polaroid picture.
2. As soon as damage is discovered or suspected, notify the carrier that delivered the shipment.
3. Arrange for the carrier's representative to examine the damage.
4. Fill out all carrier claims forms and have the examining carrier sign and date each form.

CLEARANCE REQUIREMENTS

18" is recommended for service access on the rear of kettle, 0" on the left side and 4" on the right. If adjoining equipment is over 36" high allow 4" clearance on right side.

RECOMMENDED FLOOR DRAIN LOCATION

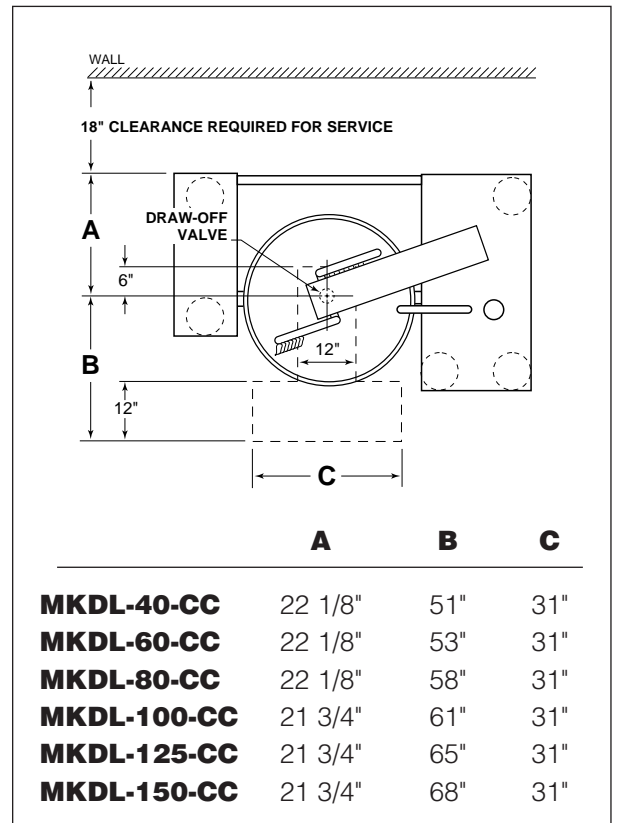

Recommended Floor Drain Location

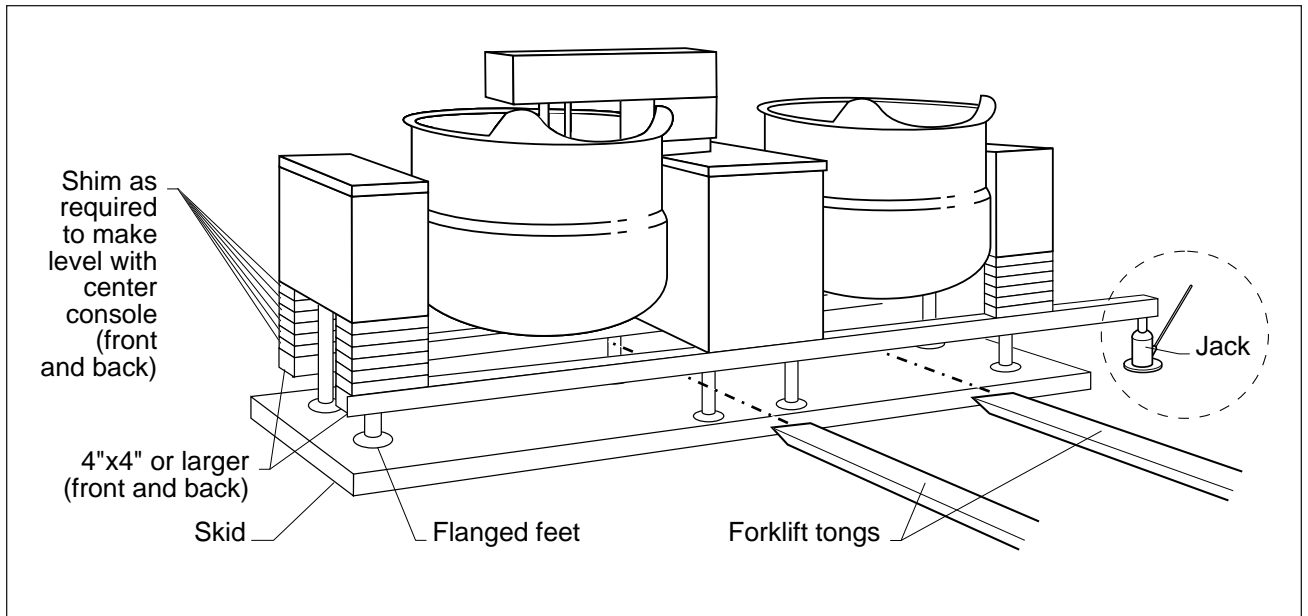

Recommended Installation Procedure

MOVING UNIT

1. While still on skid, move unit as close to final installation position as possible.
2. Prepare unit for lifting as shown in diagram.
3. Lift gently with a forklift or jacks and remove skid.
4. Lower gently to ground and remove forklift and blocking.
5. If unit has to be re-positioned, slide gently. Do not twist or push one side of unit excessively and cause binding on trunnions.

LEVELING

Note: Instructions reflect a more complicated twin mixer kettle - process for single mixer kettles is the same.

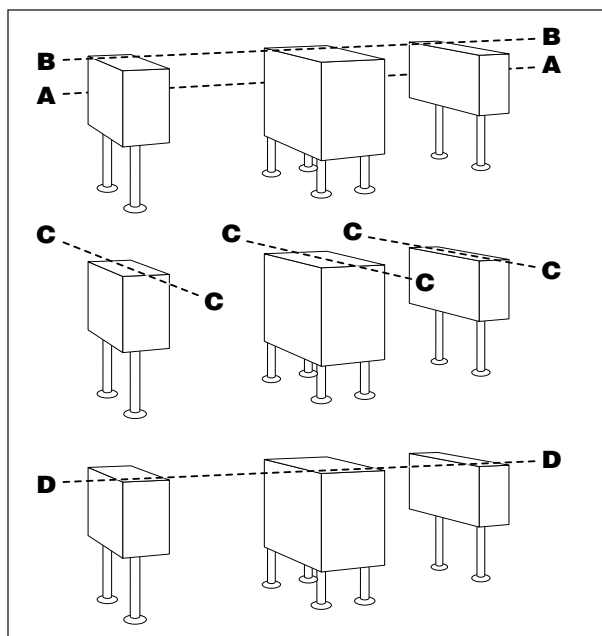

Recommended Leveling Procedure

1. With straight-edge, line the backs of the consoles up with each other (dotted line **A**).
2. Level and straight-edge backs of consoles (dotted line **B**). Adjustments are made by turning flanges on back feet only.

3. Level consoles individually from front to back (dotted lines **C**). Adjustments are made by turning flanges on front feet only.
4. Re-check that the back is level (dotted line **B**) and then the front (dotted line **D**). Adjust if necessary.

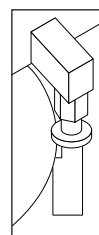

Guide Pins

5. Check that mixer bridge is level and guide pins lock smoothly without binding. If not repeat steps **1** through **4**.

NOTE: See Operating Instructions before operating unit.

6. Make electrical connections (see electrical service connections) and test mixer bridge as follows:

- ⇒ **A/** Raise mixer bridge.
- ⇒ **B/** Swing bridge out over centre console.
- ⇒ **C/** Swing bridge to the left as far as possible.

- ⇒ **D/** Lower bridge.
 - ⇒ **E/** Bridge pins should enter pin hole on kettle perfectly, If not return to step 1 and repeat leveling steps.
 - ⇒ **F/** Raise bridge and swing to far right (for twin mixers only).
 - ⇒ **G/** Repeat steps **D** and **E** (for twin mixers only).
- 7.** Once positioned and leveled, permanently secure the kettle's flanged feet to the floor using 5/16 inch stainless steel lag bolts and floor anchors (supplied by the installer). Secure each of the flanged feet with one bolt in each hole.
 - 8.** Connect piping as described in the "PIPING CONNECTION" section.

ELECTRICAL SERVICE CONNECTIONS

Install in accordance with local codes and/or the National Electric Code ANSI/NFPA No 70-1981 (USA) or the Canadian Electric Code CSA Standard C22.1 (Canada). A separate fused disconnect switch must be supplied and installed. The kettle must be electrically grounded by the installer.

The electric supply must match the power requirements specified on the kettle's rating plate. The copper wiring must be adequate to carry the required current at the rated voltage. Refer to the specification sheet for electrical specifications.

- 1.** Ensure main power is turned off before connecting wires.
- 2.** Remove the screws at the rear of the center console cover, and remove the cover. A wiring diagram is affixed to the underside of the console cover.
- 3.** Feed permanent copper wiring 18" through the cut-out in the bottom of the console. Connect wiring in junction box in the bottom of the console.
- 4.** Turn main power back on.
- 5.** Check for correct rotation of electric motor (access by removing top front cover on center console). If rotation is incorrect, disconnect main power and reverse any two of the three live lines.
- 6.** Replace the console cover and secure it with screws.

COMPRESSED AIR CONNECTION

Mixer Kettles with an air activated discharge valve require a minimum of 90 PSI to operate correctly.

If the unit is also supplying air to a Metering Filling Station then a pressure of 100 PSI at a minimum volume of 25 CFM is required.

The air supplied to the mixer should be clean and dry. No oil should be added to the supply air. We recommend the compressed air system be equipped with a drier, filter, and automatic water dump on the air compressor receiver tank. If the distance between the tank and the unit is less than 100 feet then a minimum line size of 3/4" is required. A distance of 100 to 300 feet requires a minimum 1" line.

PIPING CONNECTIONS

- 1.** All plumbing to and from the kettle should be thoroughly cleaned and inspected for dirt and debris before the final connections to the kettle are made.
- 2.** Connect all piping according to identification tags on unit.
- 3.** Piping between boiler and kettle should be sloped and a drip condensate trap installed at lowest point.
- 4.** Insulating steam piping is recommended for safety and higher efficiency.
- 5.** To determine the correct steam supply pipe size:
 - ⇒ **A/** Find the total steam requirement using the first chart.
 - ⇒ **B/** Use the steam requirement total in the second chart to find the correct pipe size.

PIPING SCHEMATIC

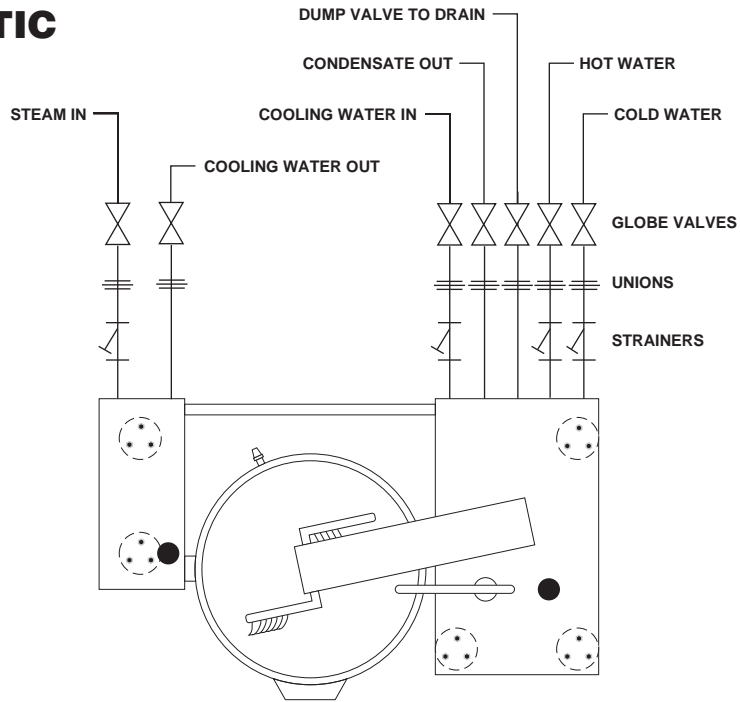

STEAM REQUIREMENTS FOR KETTLES

Kettle Cap. U.S. Gal.	Kettle Dia.	25 psi Steam 265°F		40 psi Steam 287°F		80 psi Steam 302°F	
		Lbs./Hr.	Hp./Hr.	Lbs./Hr.	Hp./Hr.	Lbs./Hr.	Hp./Hr.
40	26"	100	3	120	4	150	4.5
60	29.5"	150	4.5	190	5.5	230	7.0
80	33"	210	6.0	260	7.5	300	9.0
100	36"	260	7.5	320	9.5	390	11.0
125	40"	320	9.5	400	11.5	470	14.0
150	40"	390	11.0	480	14.0	570	17.0

- ☐ Steam requirements are maximum per hour.
- ☐ If more than one unit is on the same line then add the steam usage for each one to reach a total.

STEAM PIPE SIZING

Steam Required Lbs./Kg. per hour	Required pipe length in feet/meters		
	200 Ft. 60 Meters	400 Ft. 125 Meters	600 Ft. 185 Meters
100/45 Kg.	3/4"	1"	1 1/4"
200/91 Kg.	1"	1 1/4"	1 1/2"
300/136 Kg.	1"	1 1/4"	1 1/2"
400/182 Kg.	1"	1 1/2"	1 3/4"
500/227 Kg.	1 1/4"	1 1/2"	1 3/4"
700/318 Kg.	1 1/2"	1 3/4"	2"
900/409 Kg.	1 1/2"	1 3/4"	2"

NOTES:

- ☐ Pipe size in inches.
- ☐ Less than 50 PSI (3.4 BAR) pressure, increase pipe size by 1/4".
- ☐ 80 to 100 PSI (5.5 to 6.8 BAR), Decrease pipe size by 1/4".

QUALITY ASSURANCE CHECKLIST

Follow this list only after all other installation steps are completed. Some steps require the use of equipment. Follow operating instructions.

The following will be performed before the unit is connected to utilities:

- 1.** Visual Examine unit for scratches, dents, or other defects.
- 2.** Visual Check flanged feet all have bolts holding them.
- 3.** General Check all accessible wiring, mechanical and plumbing connections by hand for secure, tight and satisfactory assembly. Remove all paper.
- 4.** Level Check unit has been leveled and squared correctly.

The following will be performed with the unit connected to utilities:

- 5.** Raise Bridge If bridge does not raise then check motor rotation. Bridge should not raise until speed control is turned to minimum and then adjusted back up.
- 6.** Swing Bridge Bridge when fully raised should swing without hitting any object, i.e. control housing, kettle lip. Check that hydraulic hoses are not being pinched by stops on swivel assembly.
- 7.** Tilt Kettle Kettle tilts smoothly both down and back up. If power tilt, check that micro switches are adjusted properly (kettle is level in upright position and drains fully when tilted) and are not being crushed by gear.
- 8.** Lower Bridge Raise bridge. Switch to mix. Turn speed control to zero to reset micro switch then set speed control to number four. Check that unit does not begin to mix until bridge has lowered part way into the kettle. Check that mixer bridge pin lowers into pin hole correctly
- 9.** Speed Control - Main Main agitator arm not rotating when set at minimum but will start to move slowly on one. Speed control makes positive contact with micro switch.
- 10.** Speed Control - Secondary Set main speed control to five. Adjust secondary control from minimum to maximum. Look for considerable speed variance.
- 11.** Water Faucets Turn on hot water faucet. Turn off and check for leaks in piping and drips from faucet spout. Repeat above with cold water faucet.
- 12.** Product Discharge Valve Add water to kettle. Check for leaks from valve. Open and close valve a few times and check for leaks again.

OPTIONAL CONTROLS

Some units may not have the following items to test

- 13. Meter** Complete this test using markings on mixer arm or a measuring strip if there are no markings on the unit. Test the meter at the following values up to capacity (Should be approx. $\pm 1/4$ "). During this test check that the (interrupt) switch stops the water flow and the (continue/reset) when switched to "continue" resumes the flow without resetting the meter.

GALLONS	LITERS
5	20
20	80
40	160
80	320
100	400

When the (continue/reset) switch is turned to "reset" the displayed quantity on the meter should be erased and the count begins at zero.

For the following test fill the kettle 3/4 full of water. Have the mixer rotating with the speed control setting at three to five.

- 14. Heating Manual** (Active/Bypass) switch in "Bypass" position. (Heat/Off/Cool) switch in "Heat" position. Open manual steam valve, steam enters kettle and condensate escapes from steam trap.
For units equipped with water cooling -
1./ Automatic drain opens and discharges water from jacket,
2./ Automatic drain closes when steam starts exiting,
3./ Condensate drain opens and discharges hot water.
Close manual steam valve and you should hear steam entering kettle slow to a stop.
- 15. Cooling Manual** Turn (Heat/Off/Cool) switch to "Off". Open manual steam valve. Turn (Heat/Off/Cool) switch to "Cool". Cooling water enters kettle from large console and exits from side console.
- 16. Heating Automatic** (Heat/Off/Cool) switch in "Off" position. Open manual steam valve. Follow operating instructions on label to set the temperature to 180°F/ 90°C. Turn (Active/Bypass) switch to "Active", you should hear steam entering kettle and condensate should escape steam trap.
For units equipped with water cooling -
1./ Automatic drain opens and discharges water from jacket,
2./ Automatic drain closes when steam starts exiting,
3./ Condensate drain opens and discharges hot water.
- 17 Chart Recorder** **a)** Seal chart recorder on the inside all around to the panel with silicone.
b) Seal pipe penetration where cables enters panel from console with silicone all around.

OPERATING INSTRUCTIONS

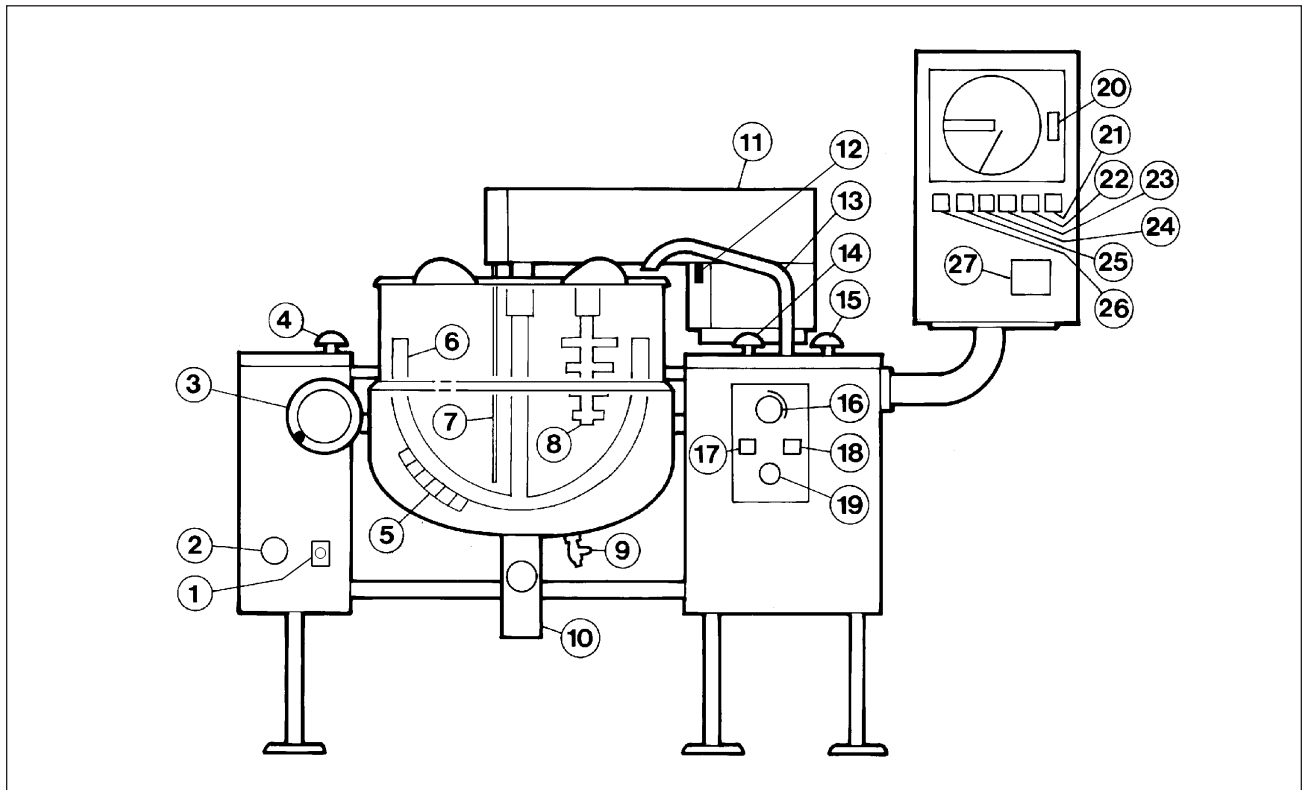

Operating Controls & Indicators

ITEM NO.	DESCRIPTION	FUNCTION
1.	Air Quick Connect	Connection for air to food pump.
2.	Air Regulator	Opens and closes air operated product discharge valve (Item 10).
3.	Hand Wheel	Tilts kettle for pouring. May be replaced by tilt switch if unit is power tilt.
4.	Steam Valve	Manually controls the amount of steam entering the kettle.
5.	Scraper Blades	Scrapes the side of the kettle and moves product away.
6.	Main Agitator Arm	Provides most of the product movement.
7.	Temperature Probe	Probe holds temperature sensors for controller.
8.	Secondary Arm	Provides reverse agitation and product lift in kettle.
9.	Drain Cock	Used to manually drain condensate from kettle.
10.	Product Discharge Valve	Discharge valve for product in the kettle.
11.	Mixer Bridge	Encloses agitator motors.
12.	Secondary Speed Control	Controls speed of secondary agitator arm.
13.	Faucet Spout	Delivers water to the kettle.
14.	Hot Water Valve	Turns on hot water.
15.	Cold Water Valve	Turns on cold water.
16.	Mixer Speed Control	Controls speed of agitators and mixer bridge lift mode.
17.	Mix/Lift Switch	Sets hydraulics to mix or lift mode.
18.	Up/Down Switch	When unit is in lift mode, bridge can be raised or lowered with this switch.
19.	Emergency Stop	Stops hydraulic system.
20.	Controller Keypad	Used to set temperature parameters.
21.	On/Off Switch	Power switch to water meter.
22.	Start Switch	Starts water flow to kettle.
23.	Interrupt Switch	Interrupts flow without resetting water meter.
24.	Active/Bypass Switch	Switch to activate or bypass (manual operation) the controller.
25.	Controller Switch	Dual function switch for auto mode or manual heat, cool or off mode.
26.	Main Power Switch	Power switch for unit.
27.	Water Meter Control	Display and setting for water meter.

Operating Suggestions

Cleveland Range Mixer Kettles are simple and safe to operate. The following tips will allow you to maximize the use of your new mixer.

1. To achieve optimum performance on tilting kettles;
Before applying steam to a cold kettle, open the DRAIN COCK (9) to drain condensate from the kettles jacket. Close drain cock when unit is fully drained.
2. Allow unit to preheat before addition of product to kettle. However when cooking egg and milk products, the kettle should NOT be preheated, as products of this nature adhere to hot cooking surfaces. These types of foods should be placed in the kettle before heating is begun.
3. An important part of kettle cleaning is to prevent foods from drying on. For this reason, cleaning should be completed immediately after cooked foods are removed. Refer to the "Care and Cleaning" instructions for detailed kettle washing procedures.
4. If a mixer bridge is equipped with a temperature probe for a controller or thermometer, the probe must be submerged a minimum of three inches in the product for accurate readings.

Safety

1. Close PRODUCT DISCHARGE VALVE (10) before filling the kettle.
2. When raising or lowering MIXER BRIDGE (11), insure FAUCET SPOUT (13) is not in the way of MAIN AGITATOR ARM (6) or damage to spout will result.
3. As a safety precaution the MIXER SPEED CONTROL (16) must first be turned to zero before unit will start to mix.
4. Always remember, like a cooking pot the kettles become very hot when cooking. Avoid contact with bare skin.

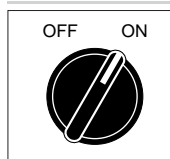

General Operation

1. Turn MAIN POWER SWITCH (26) to "ON".

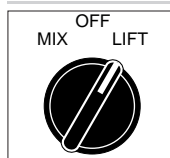

Lifting & Lowering Bridge

WARNING- Insure FAUCET SPOUT (13) is out of way before raising or lowering bridge.

1. Turn MIX/LIFT SWITCH (17) to "LIFT".
2. Turn MIXER SPEED CONTROL (16) to "MIN" and back up to #5.
3. Turn and hold UP/DOWN SWITCH (18) "UP" to raise or "DOWN" to lower.

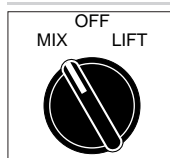
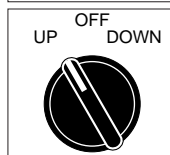
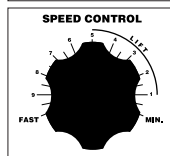

Mixing

1. Turn MIX/LIFT SWITCH (17) to "MIX".
2. Turn MIXER SPEED CONTROL (16) to "MIN" and slowly adjust to desired speed.
3. Adjust SECONDARY SPEED CONTROL (12) to desired speed.

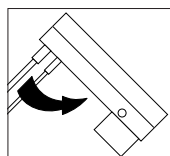
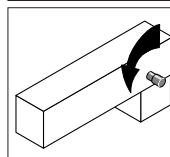
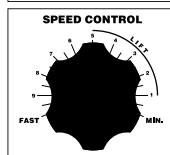

Tilting Kettle

1. Raise MIXER BRIDGE (11) and swing to side.
2. For **manual tilt**: turn HANDWHEEL (3).
3. For **power tilt**: turn switch "↑" to raise, or "↓" to tilt.

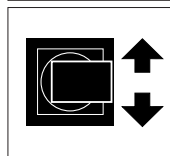
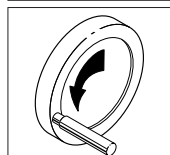

WARNING- Do not tilt kettle when mixer agitators are in kettle bowl.

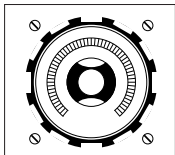

Discharge Valve

1. For **air valve**: turn AIR REGULATOR (2) clockwise to open, or counterclockwise to close.
2. For **butterfly valve**: push handle in and pull upwards to open.

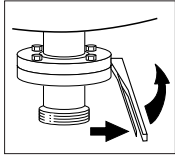

Adding Water Manually

1. Locate FAUCET SPOUT (13) over desired kettle.
2. Turn on HOT or COLD WATER VALVES (14 or 15).

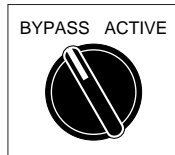
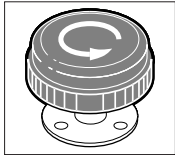

Manual Heating/Cooling

1. Turn ACTIVE/BYPASS SWITCH (25) to "BYPASS".
2. Turn CONTROLLER SWITCH (25) to "HEAT" or "COOL".
3. **For heat**: open STEAM VALVE (4) completely to boil, or adjust to regulate temperature.
For cooling: open STEAM VALVE (4) completely.

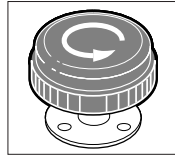
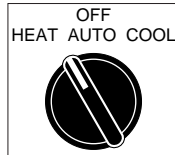

DIGITAL WATER METER OPERATING INSTRUCTIONS

Note: The digital counter has been preset at the factory and should operate satisfactory. If installing a new counter (or the configuration settings to your existing digital counter become corrupted) you must configure the digital counter as shown in Service Bulletin SE90036 prior to operation.

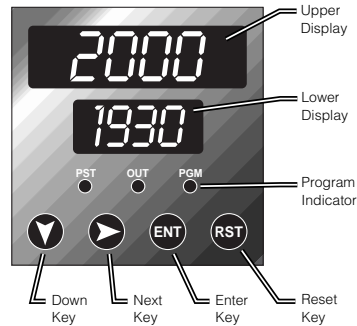

- 3 Locate delivery spout over desired kettle.



- 4 Turn START switch to "RESET". Delivery will start at "0" and stop at preset volume.



- 5 To stop delivery at any time, turn INTERRUPT switch to "•".



- 6 To complete delivery after interrupting, turn START switch to "CONTINUE"



- 7 Turn POWER switch to "OFF" when meter is not in use.



- 1 Turn POWER switch "ON".

- 2 Set required volume by first pushing the **ENT** key until the digit you want to change is flashing in the lower display. Then use the **Down** key to change the value of the selected digit.

When all digits are set, press the **ENT** key.

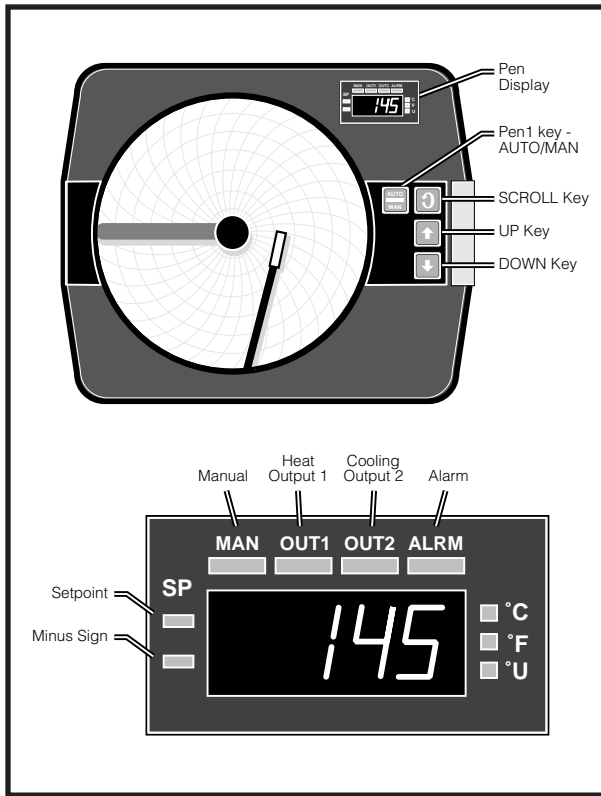

MRC 7000 Controls Drawing (1 pen)

MIXER KETTLE OPERATION USING MRC 7000 (1 PEN)

Note: Temperature probe on mixer bridge must be covered with a minimum of three inches of product to function correctly.

1. Turn MAIN POWER switch to "ON".
2. Turn HEAT/COOL switch to "OFF/AUTO".
3. Turn ACTIVE/BYPASS switch to "ACTIVE".
4. Open steam valve completely.
5. On controller keypad push and hold key "↓" or "↑" until desired temperature is set.
6. To **start**: push scroll key "↻" until "Ctrl" is displayed.
7. Push down key "↓".
8. To **stop**: push scroll key "↻" until "OFF" is displayed.
9. Push down key "↓".

NOTE: For twin kettles, the MRC 7000 will control the kettle the mixer is in.

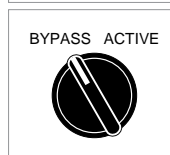
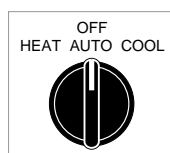
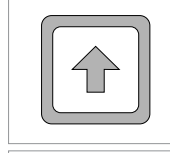
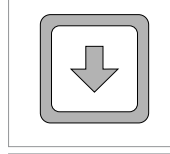
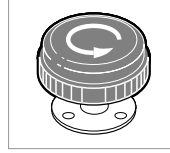
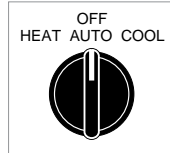
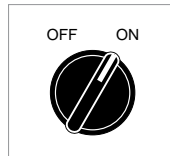

If the unit is used continually it may be simpler to control the "ON/OFF" function with the following steps:

1. Keep HEAT/COOL switch at "OFF/AUTO".
2. To stop turn ACTIVE/BYPASS switch to "BYPASS".
3. To change temperature setting push and hold key "↓" or "↑" until desired temperature is set.
4. To start, turn ACTIVE/BYPASS switch to "ACTIVE".

CLEANING INSTRUCTIONS

PRE-PRODUCTION SANITIZING PROCEDURE

NOTE: *The kettle must be sanitized prior to the daily production run.*

1. Fill kettle to hemisphere and start the agitator.
2. Add 5.25% bleach to make a 50 ppm solution - refer to chart.

Amount of water in the kettle	Amount (5.25%) of bleach to add
20 gal / 76L . . .	5 tbsp / 75ml
30 gal / 114L . . .	7 1/2 tbsp / 113ml
40 gal / 151L . . .	10 tbsp (5/8 cup) / 150ml
50 gal / 190L . . .	12 1/2 tbsp. (3/4 cup + 1 tbsp) / 188ml
60 gal / 227L . . .	1 cup / 225ml

Sanitizing Solution Chart

3. Bring the temperature to 80°F (100°F max.) or lukewarm.

NOTE: Do not allow solution to get hot.

4. Drain solution by opening valve and letting the contents of the kettle drain.
5. If you are using a metering filling station in conjunction to the kettle attach the metering filling station to the kettle and pump on continuous setting for one minute. Make sure the 3" food dia. hose from kettle to metering filling station does not drag on the floor (when disconnected from either the kettle or food pump).

GENERAL

Your Cleveland kettle must be cleaned regularly to maintain its fast, efficient cooking performance, and to ensure its continued safe, reliable operations.

⇒ Always turn off equipment power before using water.

⇒ When cleaning kettle exterior, allow kettle to cool before washing.

⇒ Never use steel wool for cleaning kettle; particles may become embedded and rust.

⇒ Use warm water and mild detergent solution, followed by a clear rinse and a properly diluted sanitizing solution (see Sanitizing Solution Chart) to sanitize kettle after cleaning.

⇒ Do not use chloride cleaners: they may damage stainless steel surface

⇒ For difficult cleaning applications, one of the following can be used: alcohol, baking soda, vinegar, or a solution of ammonia in water.

⇒ Leave the cover and draw-off valve open when the kettle is not in use.

NOTE: Do not mix ammonia and chlorine solution.

1. Fill kettle as needed with warm water and a mild detergent solution.

⇒ To remove starch and other residue, allow kettle to soak 5-10 minutes.

2. Using a nylon brush, remove food deposits inside kettle.

⇒ If food is stuck, allow kettle to soak at a low temperature setting (below 120°F).

3. Open dump valve to drain wash water.

NOTE: Interior of tilt kettles can be cleaned more easily when slightly tilted.

AUTOMATIC DUMP VALVE

Daily - clean automatic dump valve as follows:

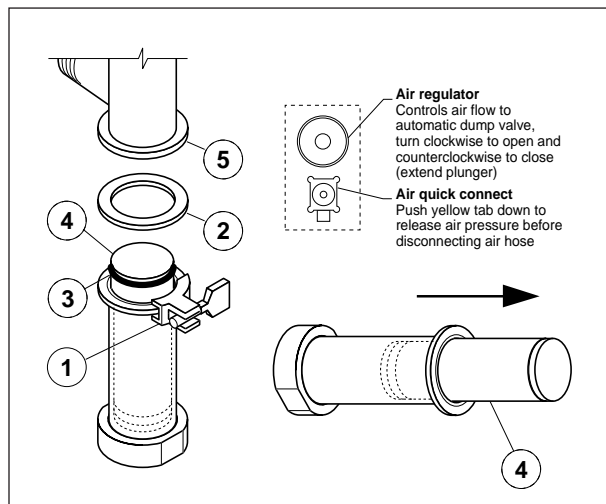

Automatic Dump Valve

To remove valve from kettle:

1. Place valve in open position.
2. Holding bottom of valve, loosen and remove sani-clamp (1).
3. Lower valve, and remove from body.
4. Remove sani-clamp seal (2) and "O" ring (3).
5. With valve on its side, turn air dial counterclockwise to extend plunger (4).
6. Disconnect air supply at valve.
7. Being careful not to submerge entire valve in water, wash plunger (4), cylinder and "T" spout on kettle (5), "O" ring (3) and seal (2).

⇒ Wash in a sink, using a warm water and mild detergent solution.

⇒ Rinse with fresh water and then sanitize using a properly diluted sanitizing solution.

⇒ Allow to air dry thoroughly on a flat, clean surface.

To install valve on kettle:

1. Replace "O" ring (3) and seal (2) if worn.
2. Coat plunger (4) and "O" ring with cooking oil or food safe grease.
3. Coat kettle cylinder (5) with cooking oil.
4. Reconnect air supply.
5. With valve on its side, place valve in open position (plunger (4) retracts into valve) by turning air regulator clockwise.

6. Put valve in place, and secure with sani-clamp (1).

BUTTERFLY VALVE

1. Place valve in open position.
2. Wash using a warm water and mild detergent solution.
3. Use a nylon brush, remove food deposits.
4. Rinse with fresh water and then sanitize using a properly diluted sanitizing solution.
5. Leave valve open when kettle is not in use.

SCRAPER BLADES

1. Remove retaining ring and slide scraper blades off agitator arm.
2. Place parts in a pan of warm water to soak.
3. Clean in a sink, using a warm water and mild detergent solution.
4. Rinse with fresh water and then sanitize using a properly diluted sanitizing solution.
5. Allow to dry thoroughly on a flat, clean surface.

SANITIZING

Now that the kettle is completely clean, sanitize kettle. Using a spray bottle, spray 50ppm sanitizing solution on kettle's interior and exterior. Allow to dry thoroughly.

⇒ When kettle is not in use, leave cover off.

⇒ Do not leave water standing in kettle overnight.

NOTE: Before adding product to kettle, refer to Preproduction Sanitizing Procedure.

SERVICE PARTS

WARRANTY

Our Company supports a worldwide network of Maintenance and Repair Centers. Contact your nearest Maintenance and Repair Centre for replacement parts, service, or information regarding the proper maintenance and repair of your cooking equipment

In order to preserve the various agency safety certification (UL, NSF, ASME/Ntl. Bd., etc.), only factory-supplied replacement parts should be used. The use of other than factory supplied replacement parts will void warranty.

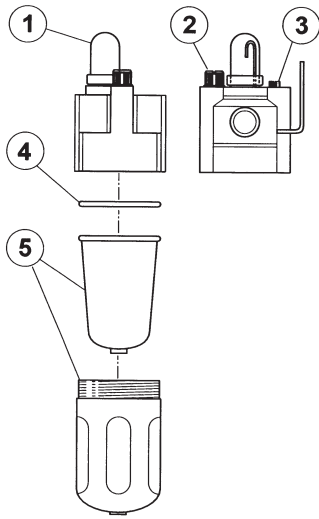

LUBRICATOR

ITEM NO.	PART NO.	DESCRIPTION	QTY.
1.-5	KE52815	Lubricator c/w Bracket	1
1.	SE50418	Sight Dome	1
2.	SE50419	Filler Cap	1
3.	SE50420	Needle Valve	1
4.	SE50422	"O" Ring	1
5.	SE50423	Bowl/Guard	1

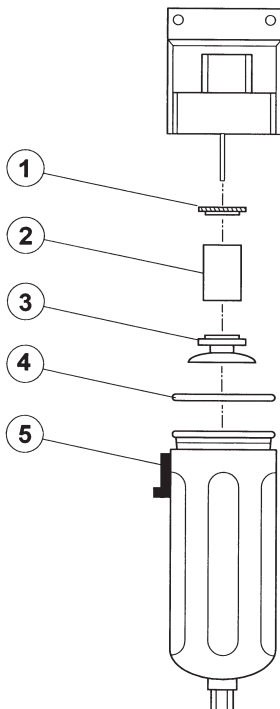

FILTER

ITEM NO.	PART NO.	DESCRIPTION	QTY.
1.-5	KE52031	Filter c/w Bracket	1
1.	SE50425	Deflector	1
2.	SE50426	Filter Element	1
3.	SE50427	Baffle	1
4.	SE50428	"O" Ring	1
5.	SE50429	Bowl/Guard	1

REMOTE CONTROL ASSEMBLY

NOTE: See SWITCH CONFIGURATIONS for applicable contact cartridge/capacitor combinations and part numbers

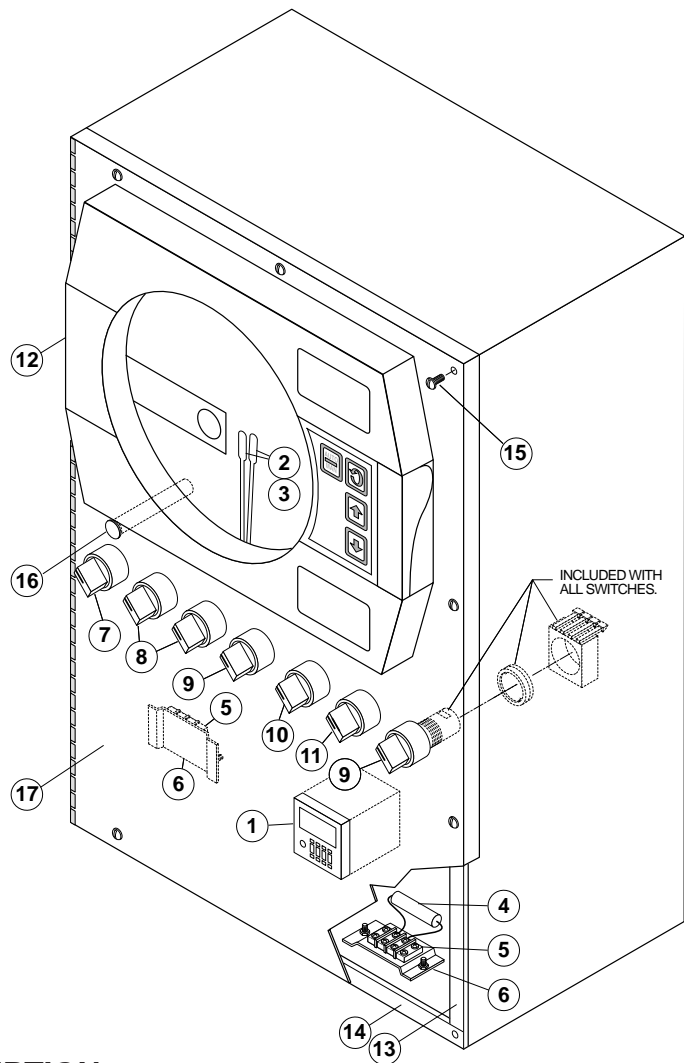

ITEM NO.	PART NO.	DESCRIPTION	QTY.
1.	KE53257	Digital Counter	.1
2.	SE50354	Pen Tip, red (pkg. of 5)	.1
3.	SE50354	Pen Tip, green (pkg. of 5)	.1
4.	KE01820	Ambient Heater Assembly	.1
5.	SK50370	Terminal Block	.1
6.	KE54402	Mounting Bracket, Terminal Block	.1
7.	KE01808	Switch Assembly, On/Off - Maintained	.1
8.	KE01809	Switch Assembly, On/Off/On - Maintained (single kettle)	.1
		(twin kettle)	.2
9.	KE01808	Switch Assembly, On/Off - Maintained	.2
10.	KE01810	Momentary Spring Return Switch Assembly	.1
11.	KE01811	Momentary Spring Return Switch Assembly	.2
12.	KE53136-1	Chart Recorder	.1
13.	KE53131	Gasket, 24 1/4"	.2
14.	KE53132	Gasket, 15 3/4"	.2
15.	FA11091	Screw	.10
16.	SK50315-1	Pilot Light	.1
17.		Label:	.1
	KE95439	English	
	KE95439-1	French	

MAIN CONSOLE CONTROLS

NOTE: See SWITCH CONFIGURATIONS for applicable contact cartridge/capacitor combinations and part numbers

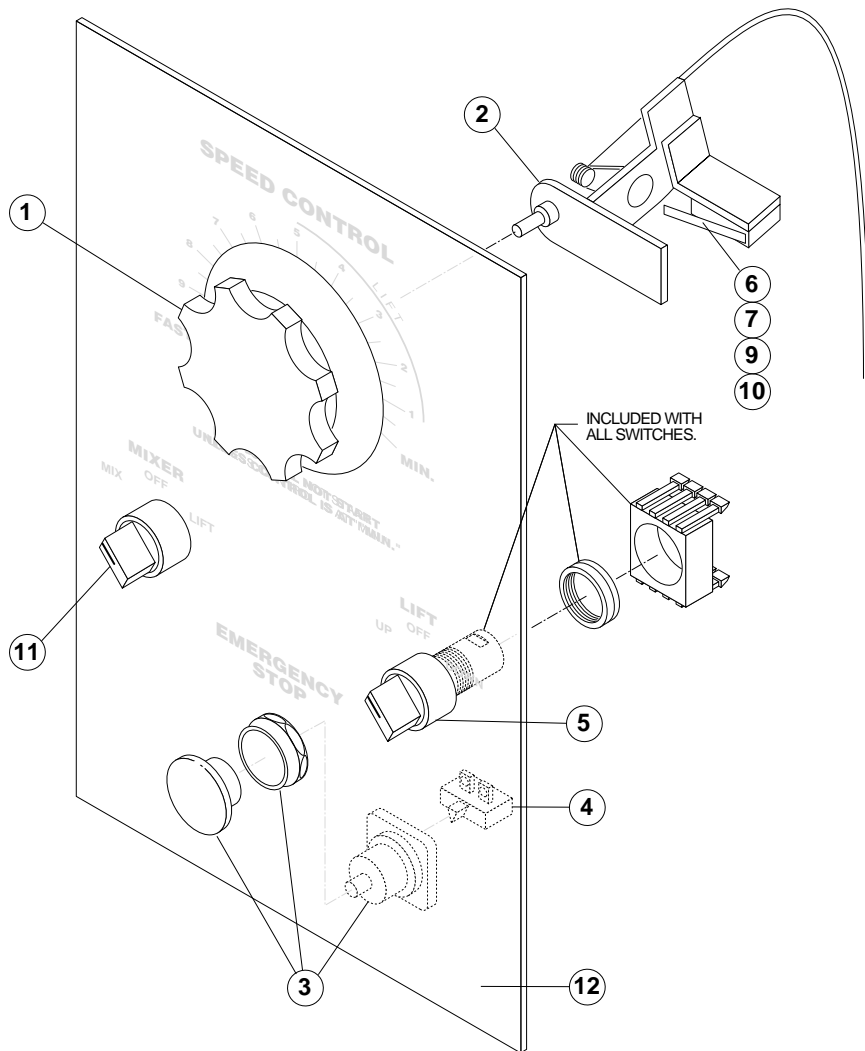

ITEM NO.	PART NO.	DESCRIPTION	QTY.
1.	KE52190	Knob, Speed Control	1
2.	KE00860	Cable and Bracket, Speed Control	1
3.	KE53193	Emergency Switch	1
4.	KE53377	Push Button Contact Block	1
5.	KE01811	Switch Assembly, On/Off - Momentary	1
6.	KE52180	Micro Switch	1
7.	FA10032	Machine Screw, #4-40 x 5/8" LG	2
9.	FA32002	Tooth Lock Washer, #4	2
10.	FA20000	Hex Nut, #4-40	2
11.	KE01809	Switch Assembly, On/Off/On - Maintained	1
12.		Label:	1
	KE95328	English	
	KE95328-1	French	

SWITCH CONFIGURATION

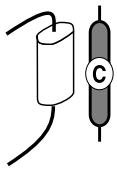
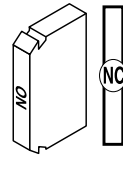
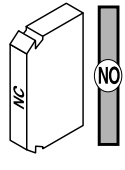
INDEX		
Capacitor	Contactor Cartridges	
 <p>C</p>	 <p>NO (normally open - green)</p>	 <p>NC (normally closed - red)</p>
PART NO.		
KE52074	KE53138-1	KE53138

NOTE: Refer to Maintenance Section for Switch Disassembly Instructions.

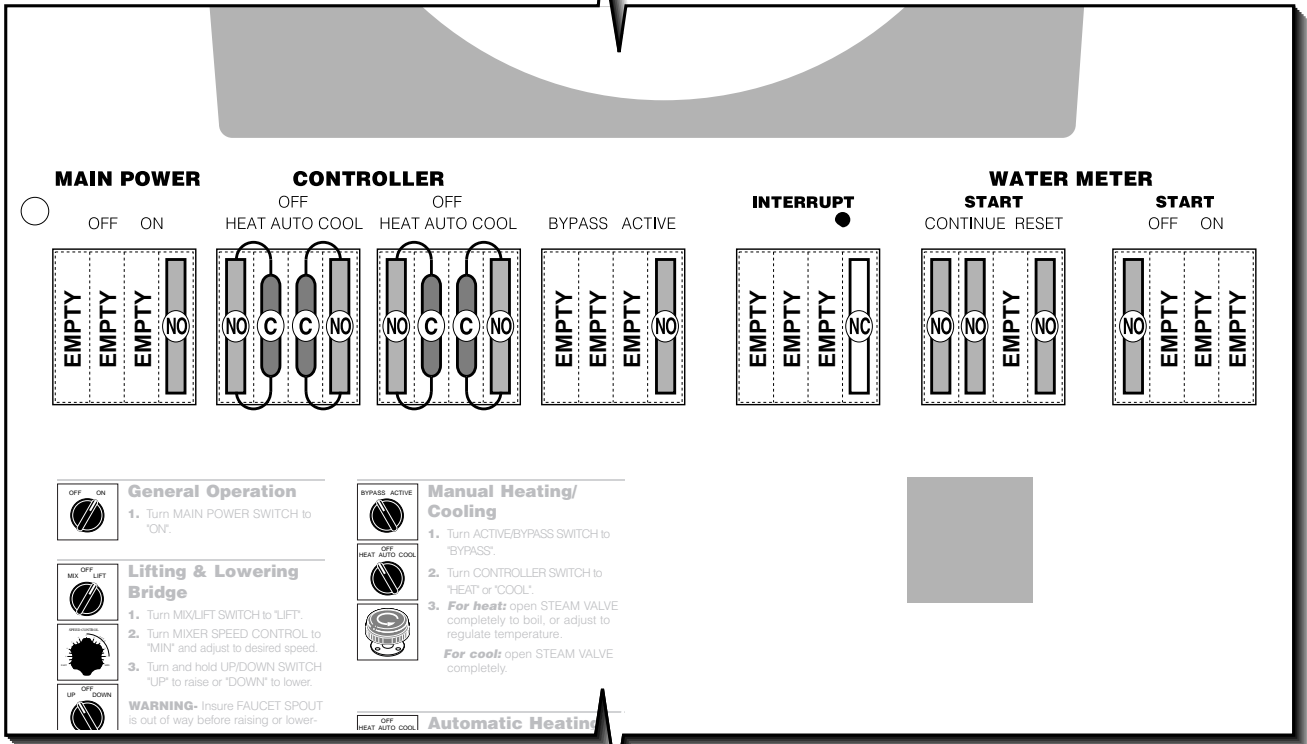
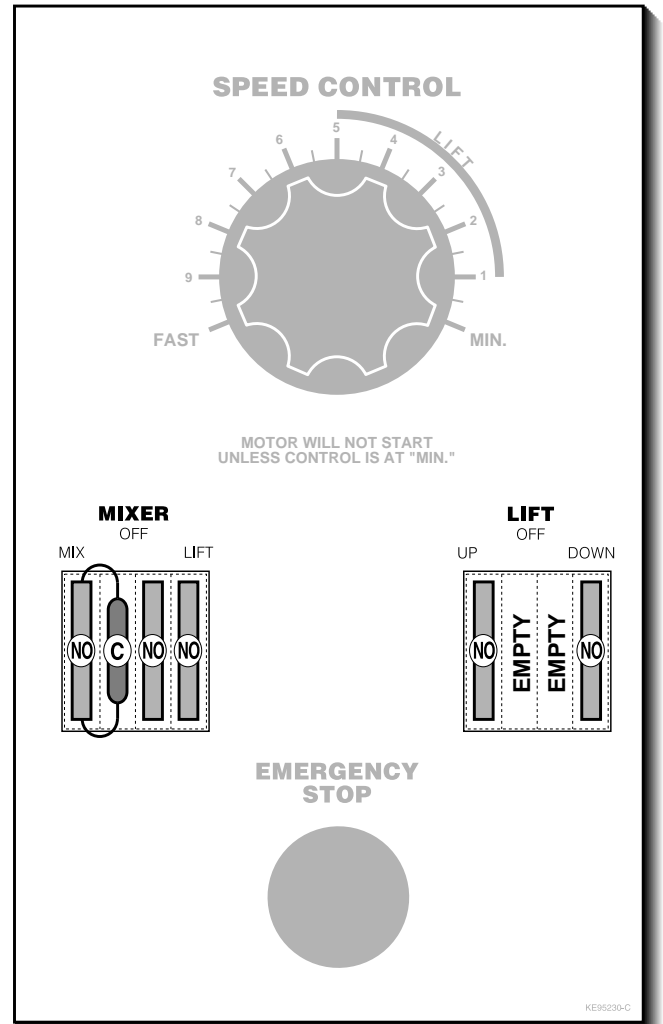

HYDRAULIC COMPONENTS

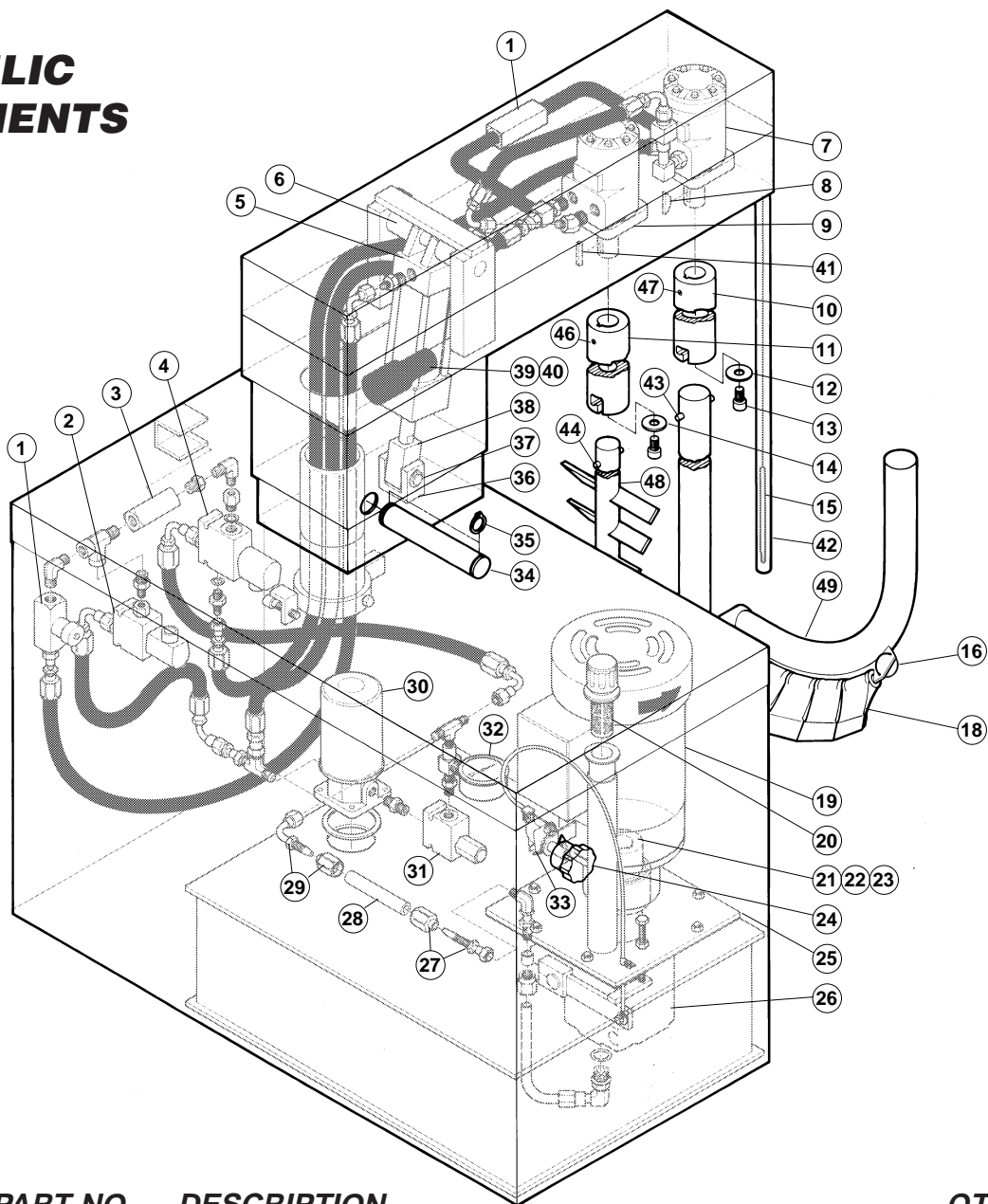

ITEM NO.	PART NO.	DESCRIPTION	QTY.
1.	KE51607	Flow Control Valve	2
2.	KE54834-10	Solenoid Valve, 2 Way, 120 Volt	1
	SE50224	Coil Only 120 Volt	1
3.	KE51608	Check Valve	1
4.	KE54834-11	Solenoid Valve, 3 Way, 120 Volt	1
	SE50224	Coil Only 120 Volt	1
5.	KE51848	Jack	1
	SE50241	Rod Gland Seal Kit	1
	SE50242	Piston Seal Kit.	1
6.	KE52124	Jack Upper Pin	1
7.	KE51846	Hydraulic Motor, Scraper Arm, 40 gal.	1
	KE51938	Hydraulic Motor, Scraper Arm, 60-150 gal.	
	KE53004	Hydraulic Motor, Scraper Arm, 200-250 gal.	
8.	KE85006	Woodruff Key	1
9.	KE51845	Hydraulic Motor, Secondary Agitator, 40-150 gal.	1
	KE53005	Hydraulic Motor, Secondary Agitator, 200-250 gal.	
10.	KE51715	Main Coupling, Scraper Arm	1
11.	KE51716	Secondary Coupling, Agitator Arm	1
12.	KE52114	Coupling Washer, Primary S.S.	1
13.	FA11286	Socket Head Screw	2

ITEM NO.	PART NO.	DESCRIPTION	QTY.
14.	KE52115	Coupling Washer, Secondary S. S.1
15.	CT50097	R.T.D Probe Single1
16.	KE53962	Blade Stop Ring2
18.	KE51834	Scraper Blades as required	
19.	KE51875	Electric Motor 3 hp., 40-150 gal.1
	KE52993	Electric Motor 5 hp., 200-250 gal.1
20.	KE51889	Filter, Tank Breather1
21.	KE52222	Gear, 3/4" I.D. Pump1
22.	KE52223	Gear, 7/8" I.D. Motor1
23.	KE52224	Nylon Coupling.1
24.	KE52190	Speed Control Knob1
25.	KE52171	Gasket, Oil Tank1
26.	KE51844	Hydraulic Pump1
27.	FI05060	Swivel adapter5
28.	SE50280	Hydraulic Hose, Per Foot40
29.	FI05061	Swivel Elbow. 90 Degrees9
30.	SE50094	Oil Filler1
31.	KE51874	Pressure Relief Valve, Hydraulic1
32.	KE52382	Pressure Gauge1
33.	KE00860	Speed Control Cable Assembly1
34.	KE51622	Bridge Tilt Pin1
35.	FA95022	Retaining Ring1
36.	KE51623	Clevis Bracket1
37.	SE50353	Clevis Pin c/w Clips1
38.	KE51624	Knuckle Joint1
39.	KE50295	Mounting Bracket, Mercury Switch1
40.	KE50294	Mercury Switch	1-2
41.	FA95055-3	Woodruff Key1
42.	KE52304	Housing, probe, 40 gal.1
	KE52305	Housing, probe, 60 gal.1
	KE52306	Housing, probe, 80 gal.1
	KE52307	Housing, probe, 100 gal.1
	KE52308	Housing, probe, 125 gal.1
	KE52309	Housing, probe, 150 gal.1
	KE523091	Housing, probe, 200 gal.1
	KE523092	Housing, probe, 250 gal.1
43.	KE51925	Pin, Secondary Agitator1
44.	KE51924	Pin, Scraper Arm1
45.	KE00935	Secondary Agitator, 40 gal.1
	KE00937	Secondary Agitator, 80 gal.1
46.	FA19506	Set Screw, Secondary Agitator1
47.	FA19507	Set Screw, Scraper Arm1
48.	KE00935	Secondary Agitator, 40 gal.1
	KE00936	Secondary Agitator, 60 gal.1
	KE00937	Secondary Agitator, 80 gal.1
	KE00938	Secondary Agitator, 100 gal.1
	KE00939	Secondary Agitator, 125 gal.1
	KE00940	Secondary Agitator, 150 gal.1
	KE009401	Secondary Agitator, 200 gal.1
	KE009402	Secondary Agitator, 250 gal.1
49.	KE00941	Primary Agitator Shaft Assembly, 40 gal.1
	KE00942	Primary Agitator Shaft Assembly, 60 gal.1
	KE00943	Primary Agitator Shaft Assembly, 80 gal.1
	KE00944	Primary Agitator Shaft Assembly, 100 gal.1
	KE00945	Primary Agitator Shaft Assembly, 125 gal.1
	KE00946	Primary Agitator Shaft Assembly, 150 gal.1
	KE009461	Primary Agitator Shaft Assembly, 200 gal.1
	KE009462	Primary Agitator Shaft Assembly, 250 gal.1

PLUMBING ASSEMBLY - 10" CONSOLE

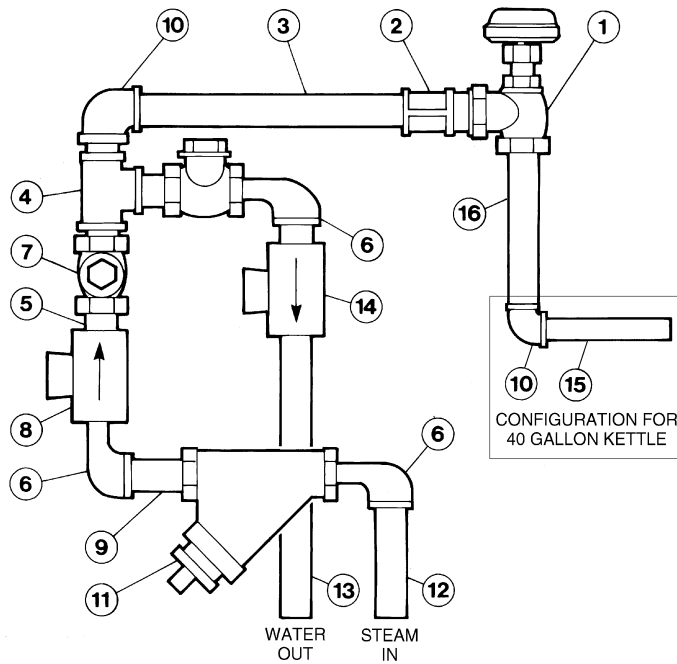

ITEM NO.	PART NO.	DESCRIPTION	QTY.
1.	KE00350	Steam Valve 3/4"	1
	KE01212	Steam Valve 1 1/4"	1
2.	FI00267	Coupling	1
3.	FI00629-31	Nipple	1
4.	FI00179	Tee	1
5.	FI00629-36	Nipple	4
6.	FI00152	Street Elbow	3
7.	KE51653	Check Valve 3/4"	2
	KE51367	Check Valve 1 1/4"	2
8.	KE54834-3	* Solenoid Valve, 3/4" - 50 psi.	1
	SE50405	Rebuild Kit	
	SE50406	Replacement Coil	
	KE54834-4	* Solenoid Valve, 3/4" - 100 psi.	1
	SE50410	Rebuild Kit	
	SE50404	Replacement Coil	
	KE54834-8	* Solenoid Valve, 1 1/4" - 100 psi.	1
	SE50409	Rebuild Kit	
	SE50404	Replacement Coil	
9.	FI00629-30	Nipple	1
10.	FI00063	Elbow	2
11.	KE51654	Y-Strainer 3/4"	1
	KE53008	Y-Strainer 1 1/4"	1
12.	FI00629-29	Nipple	1
13.	FI0062919	Nipple	1
14.	KE54834-5	* Solenoid Valve, 3/4" - 50 psi.	1
	SE50407	Rebuild Kit	
	SE50401	Replacement Coil	
	KE54834-4	* Solenoid Valve, 3/4" - 100 psi.	1
	SE50410	Rebuild Kit	
	SE50404	Replacement Coil	
15.	FI00629-4	Nipple	1
16.	FI00629-7	Nipple	1

***NOTE:** See SOLENOID VALVE MAINTENANCE section for further information.
100 gallons and up use the larger valves.

PLUMBING ASSEMBLY - 18" CONSOLE

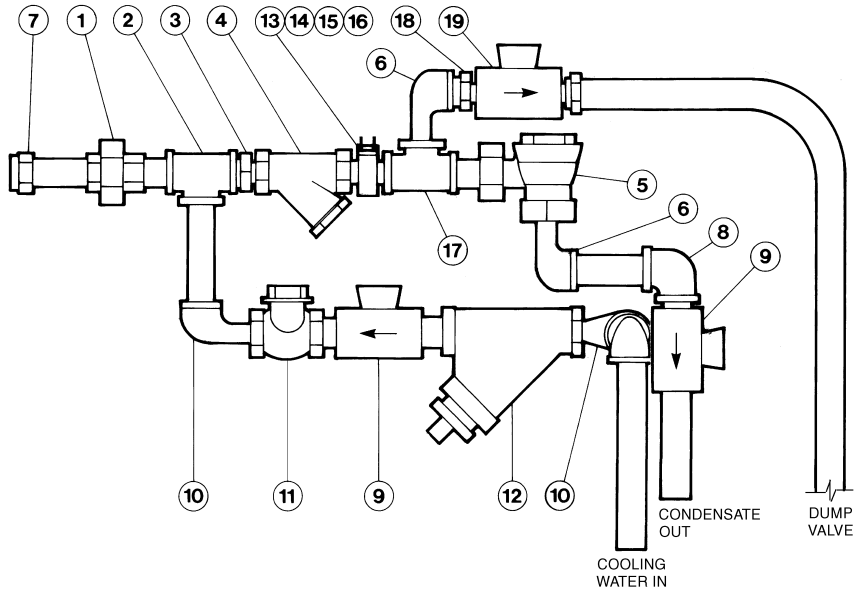
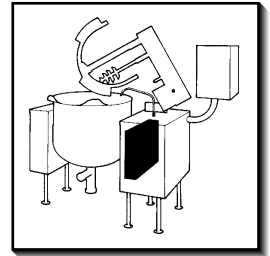

ITEM NO.	PART NO.	DESCRIPTION	QTY.
1.	FI00096	Union	.1
2.	F100179	Tee	.1
3.	F105130	Reducing Nipple	.1
4.	KE52702	Y-Strainer, 1/2"	.1
5.	KE52701	Steam Trap	.1
6.	FI00151	Street Elbow	.3
7.	FI00441	Reducing Bushing	.1
8.	FI00363	Reducing Elbow	.1
9.	KE54834-5	* Solenoid Valve, 3/4" - 50 psi.	.1
	SE50407	Rebuild Kit	
	SE50401	Replacement Coil	
	KE54834-4	* Solenoid Valve, 3/4" - 100 psi.	.1
	SE50410	Rebuild Kit	
	SE50404	Replacement Coil	
10.	FI00143	Street Elbow	.3
11.	KE51653	Check Valve	.1
12.	KE51654	Y-Strainer	.1
13.	KE52666	Thermostat Mtg. Block	.1
14.	UR50077	Thermostat	.1
15.	FA11052	Bindinghead Screw	.1
16.	FA11060	Bindinghead Screw	.1
17.	FI00178	Tee	.1
18.	FI05089	Reducing Nipple	.1
19.	KE54834-2	* Solenoid Valve, 3/8"	.1
	SE50408	Rebuild Kit	
	SE50404	Replacement Coil	

***NOTE:** See SOLENOID VALVE MAINTENANCE section for further information.

AIR SYSTEM - 10" CONSOLE

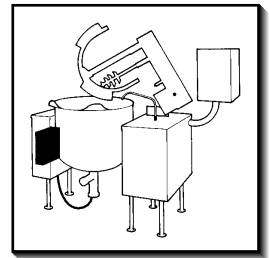
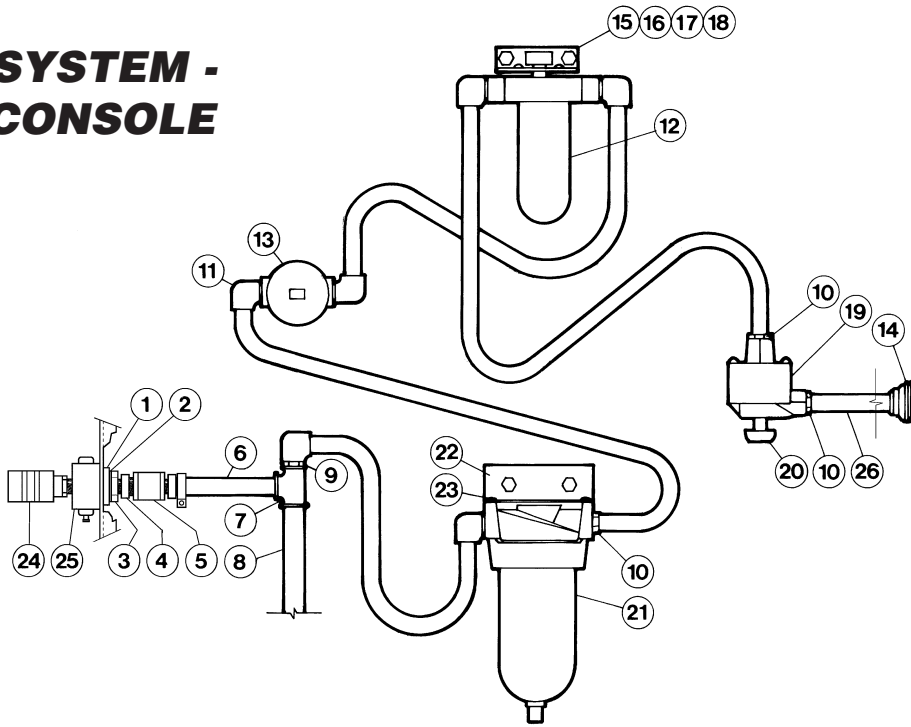

ITEM NO.	PART NO.	DESCRIPTION	QTY.
1.	FA30512	Spacer	.1
2.	FA32500	Tooth lockwasher	.1
3.	KE52697	Locking nut	.1
4.	KE52931	Adapter	.1
5.	FI00266	Coupling	.1
6.	FI00595-17	Nipple 1/2" NPT	.2
7.	FI00178	Tee 1/2" NPT	.2
8.	FI00595-12	Nipple 1/2" NPT	.1
9.	FI05047	Bushing	.1
10.	KE52342	Hose Barb	.3
11.	FI05167	Hose Barb 90 Degree Elbow	.6
12.	KE52815	Airline Lubricator	.1
13.	KE52895	Air Regulator	.1
14.	KE52339	Female End Quick Connect	.1
15.	KE52932	Bracket For Lubricator	.1
16.	FA32006	Toothlock Washer	.4
17.	FA21006	Nut	.4
18.	FA11091	Machine Screw	.2
19.	KE53209	Quick Exhaust Valve	.1
20.	KE53210	Muffler	.1
21.	KE52031	Air Line Filter c/w Bracket	.1
22.	KE53251	Air Line Filter Bracket	.1
23.	FA11144	Bindinghead Screw	.4
24.	FI05166	Quick connect	.1
25.	KE54280	Slide valve	.1
26.	KE53215	1/4" Air Hose, 65" Long	.1

MANUAL TILT - 10" CONSOLE

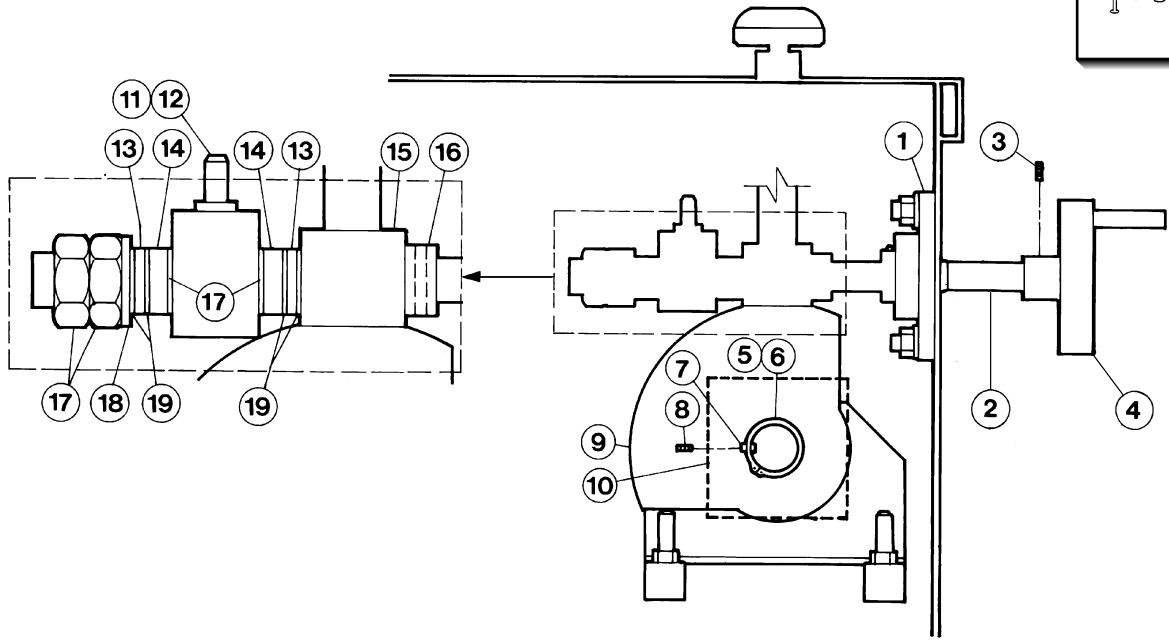
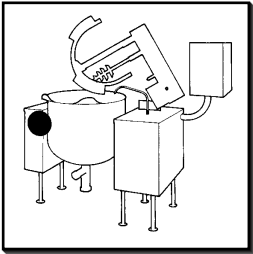

ITEM NO.	PART NO.	DESCRIPTION	QTY.
1.	KE51730	Tilt Shaft Bearing	1
2.	KE50375	Tilt Shaft, Small Gear	1
3.	FA19501	Handwheel Allen Screw, Hex Socket	1
4.	KE00508	Handwheel Assembly	1
5.	FA95007	Retaining Ring	1
6.	FA05002-6	"O" Ring	2
7.	FA95006	Woodruff Key	1
8.	FA19186	Set Screw	1
9.	KE00151	Segment Gear, Small	1
	KE52833	Segment Gear, Large	1
10.	KE00699	Trunnion Housing	1
11.	FA19177	Hex-Socket Set Screw	1
12.	FA20047	Jam Nut	1
13.	KE52191	Roller Bearing	2
14.	KE52193	Thrust Bearing Spacer	2
15.	KE50315	Worm Gear	1
16.	FA95005	Tension Pin	1
17.	FA95008	Hex Nut 3/4-16	2
18.	FA30088	Washer	1
19.	KE52192	Bearing Washer	4

POWER TILT - 10" CONSOLE

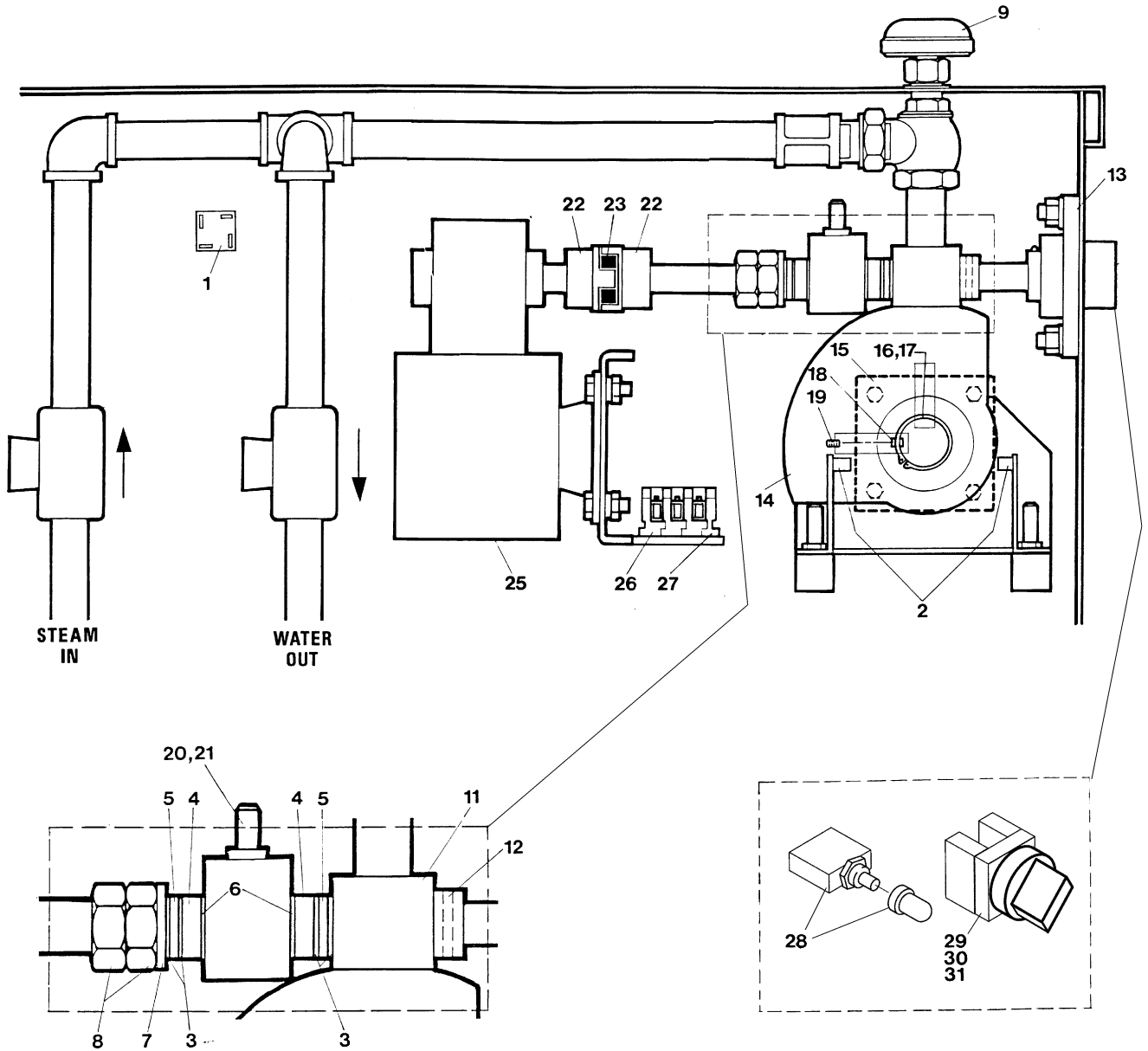
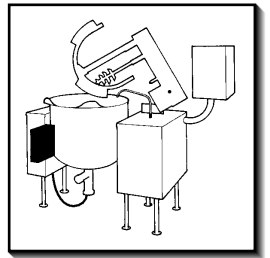

POWER TILT - 10" CONSOLE

ITEM NO.	PART NO.	DESCRIPTION	QTY.
1.	KE51007	Micro Switch	2
2.	KE50581	Bridge Rectifier	1
3.	KE52192	Thrust Washer	4
4.	KE52193	Thrust Bearing Spacer	2
5.	KE52191	Roller Bearing	2
6.	FA30088	Washer	2
7.	FA30088	Washer	1
8.	FA95008	Hex Nut, 3/4-16	2
9.	SE00028	Knob Assembly	1
11.	KE50315	Worm Gear,	1
12.	FA95005	Tension Pin	1
13.	KE51730	Tilt Shaft Bearing	1
14.	KE00151	Segment Gear, Small	1
	KE52833	Segment Gear, Large	1
15.	KE00699	Trunnion Housing	1
16.	FA95007	Retaining Ring	1
17.	FA05002-6	"O" Ring	2
18.	FA95006	Woodruff Key	1
19.	FA19186	Set Screw	1
20.	FA19177	Hex-Socket Set Screw	1
21.	FA20047	Jam Nut	1
22.	KE50582	Coupling	2
23.	KE50583	Coupling Insert	1
25.	KE52832	Motor 1/8 HP	1
26.	SK50055-1	Terminal Block	1
27.	SK50054-1	Terminal Block End-Section	1
28.	KE50579	Circuit Breaker	1
	FA05002-34	"O" Ring, Circuit Breaker	1
	KE50580	Water Resistant Boot	1
29.	KE53137-3	Momentary Switch Activator	1
30.	KE53184	Contact Section Holder (Latch)	1
31.	KE53138-1	Contact Block	4

***NOTE:** See SOLENOID VALVE MAINTENANCE section for further information.

WATER METER ASSEMBLY - 18" CONSOLE

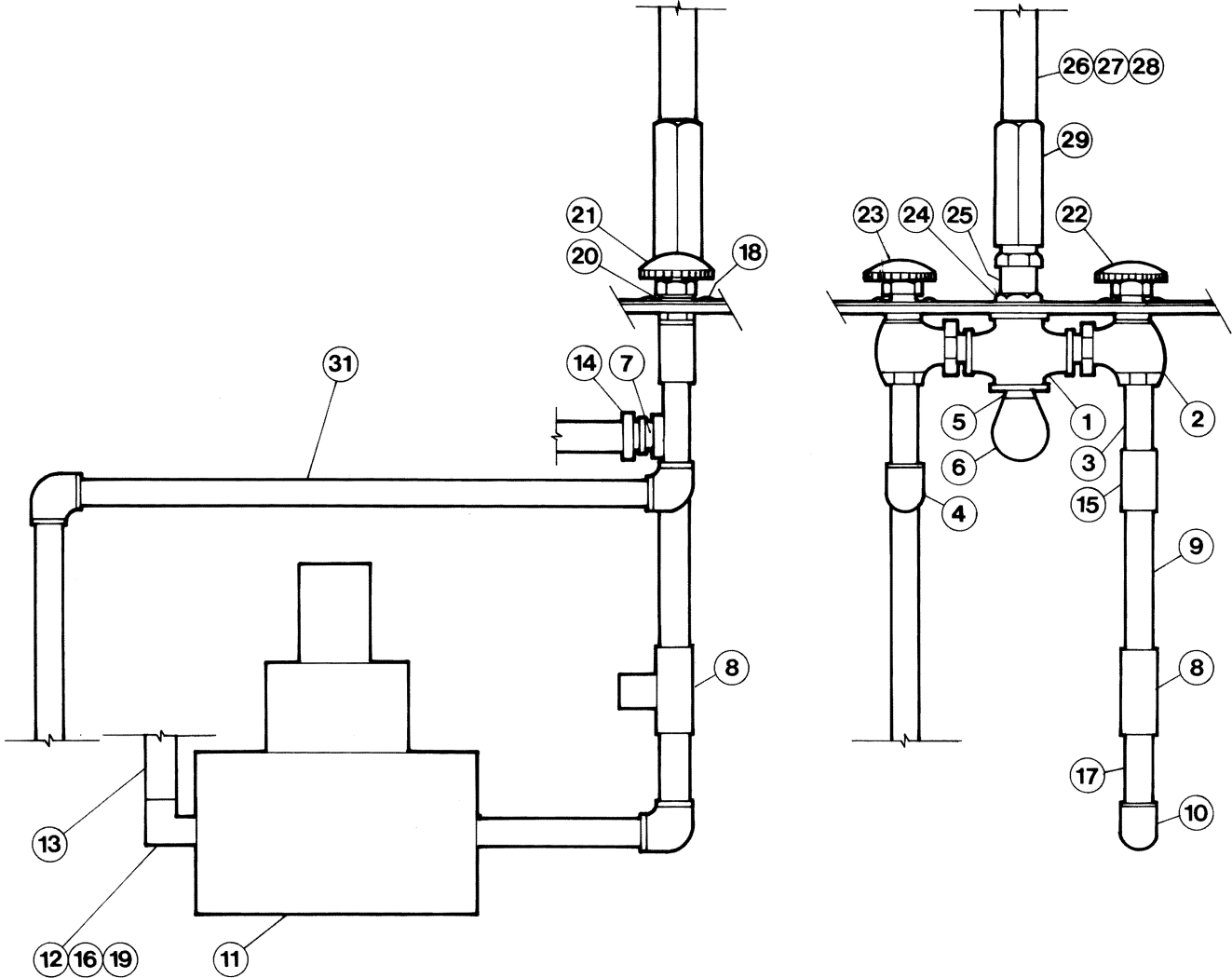
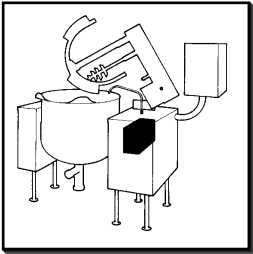

WATER METER ASSEMBLY - 18" CONSOLE

ITEM NO.	PART NO.	DESCRIPTION	QTY.
1.	FI05181	2" Butt weld Sanclamp	1
2.	KE00350	Steam Valve Modification	2
3.	FI00629-5	Nipple	2
4.	FI00063	Elbow 90 degree	1
5.	FI05128	Reducing Bushing	1
6.	F100151	Street Elbow	1
7.	F105029	Hose Barb Parker	2
8.	KE54834-5	* Solenoid Valve, 3/4"	1
	SE50407	Rebuild Kit	
	SE50401	Replacement Coil	
9.	FI00629-3	Nipple, Gallon Meter	1
	FI00629-4	Nipple, Litre Meter	
10.	FI00363	Reducing Elbow 90 Degree, Gallon Meter	1
	FI00063	Elbow 90 Degree, Litre Meter	
11.	KE51861	Gallon Meter	1
	KE52002	Litre Meter	
12.	FI00062	Elbow 90 Degree	1
13.	KE52173	1/2"1.D. Hot Water Wash-up Hose	1
14.	KE51391	Hose Clamp	2
15.	FI00179	Tee	1
16.	FI05074	Adapter, Gallon Meter	2
	FI05075	Adapter, Litre Meter	
17.	FI00629-36	Nipple	1
18.	FA11091	Machine Screw	8
19.	FI05151	Adapter Nipple, Gallon Meter	2
	FI05153	Adapter Nipple and Gasket , Litre Meter	
20.	KE51369	Steam Valve Flange	2
21.	SE00028	Knob Assembly	2
22.	KE95321	Label "Hot"	1
23.	KE95322	Label "Cold"	1
24.	SD50097	Flanged Nut	1
25.	KE51585	Faucet Spout Fitting	1
26.	KE50825-7	Faucet Spout	1
27.	FA05002-19	"O" Ring	1
28.	FA95022	Retaining Ring Carter	1
29.	KE51736	Long Faucet Nut	1

***NOTE:** See SOLENOID VALVE MAINTENANCE section for further information.

ELECTRICAL COMPONENT ASSEMBLY

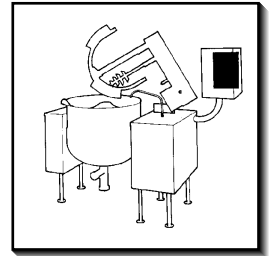
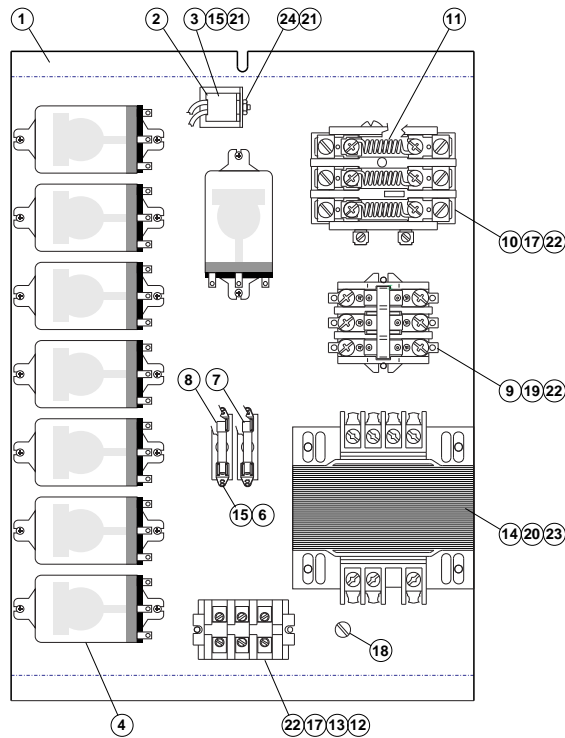

ITEM NO.	PART NO.	DESCRIPTION	QTY.
1.	KE50343-8	Component Mounting Plate	1
2.	KE52710	Thermostat	1
3.	KE52835	Bracket for Thermostat	1
4.	KE50753-10	Relays	6-9
6.	KE51139	Fuse Holder	2
7.	SK50445	Fuse (3 amps)	1
8.	KE52936	Fuse (1 amps)	1
9.	KE50750-1	Contactor	1
10.	KE51982	Thermal Overload Relays	1
11.		Heater for Thermal Overload	3
	KE52055	200, 208, 220, 240, 380 & 415 volt	
	KE52051	440, 480 volt	
12.	SK50055-1	Terminal Block Sections	3
13.	SK50054-1	Terminal Block End Section	1
14.		Transformer	1
	KE53838-5	200, 208, 220, 240, 440 & 480 volt	
	KE53838-6	380 & 415 volt	
15.	FA10133	Screws #6-32x3/8" lg.	5
16.	FA10135	Screws #6-32x1/2" lg.	7-11
17.	FA10239	Screws #8-32x3/8" lg.	6
18.	FA12500	Screws #8-32x3/8" lg. (brass with undercut)	1
19.	FA10245	Screws #8-32x1" lg.	2
20.	FA10362	Screws #10-32x3/8" lg.	4
21.	FA32004	Lockwashers #6	2
22.	FA32005	Lockwashers #8	8
23.	FA32006	Lockwashers #10	4
24.	FA20002	Hex Nut #6-32	1

FLUSH PISTON VALVE

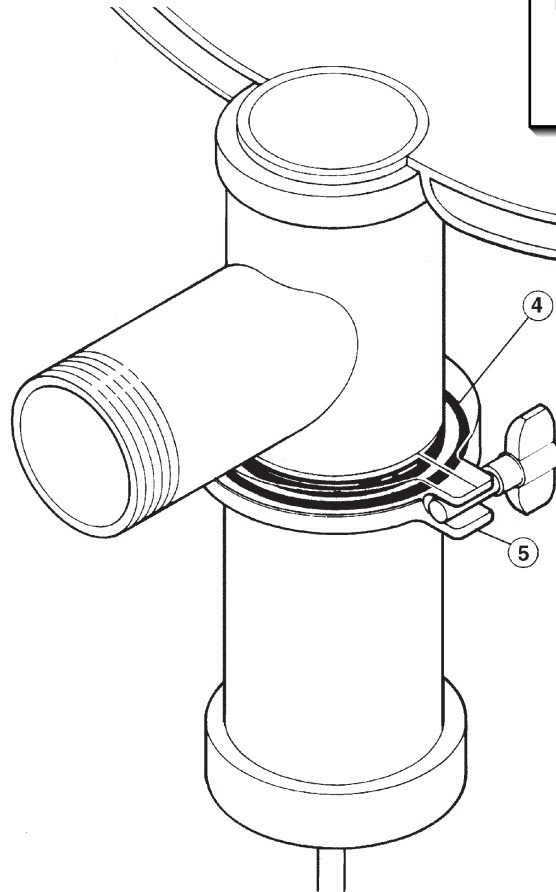
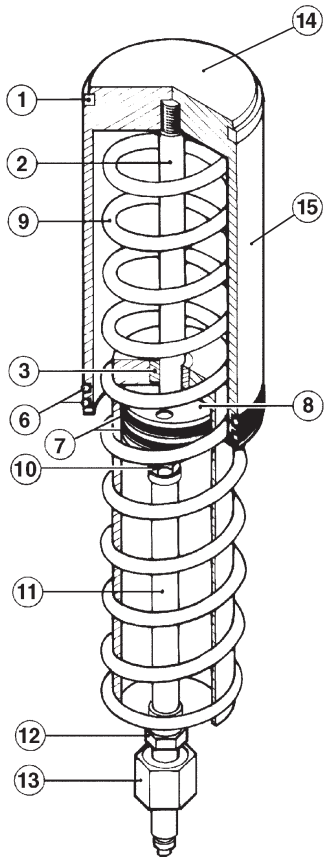
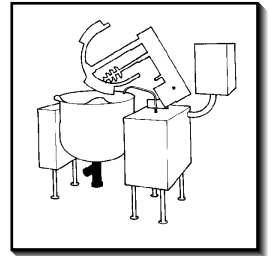

ITEM NO.	PART NO.	DESCRIPTION	QTY.
1.	FA05000	"O" Ring, Cylinder Head	1
2.	KE52345	Piston Shaft	1
3.	KE52346	Air seal	1
4.	KE52347	Sani-Clamp Seal, 4"	1
5.	KE52344	Sani-Clamp, 4"	1
6.	FA05002-22	"O" Ring, Cylinder Body	2
7.	FA05002-21	"O" Ring, Piston	2
8.	KE52315	Piston	1
9.	KE52335	Compression Spring	1
10.-13.	SE00040	Supply Hose Assembly, Piston	1
10.	KE52341	Hose Barb, 1/8" x 1/4"	3
11.	KE52340	Supply Hose, 8"	1
12.	KE52342	Hose Barb, 1/4" x 1/4"	1
13.	KE52338	Quick Connect Male End	1
14.	KE52327	Piston Top	1
15.	KE52328	Piston Cylinder	1

BUTTERFLY VALVE

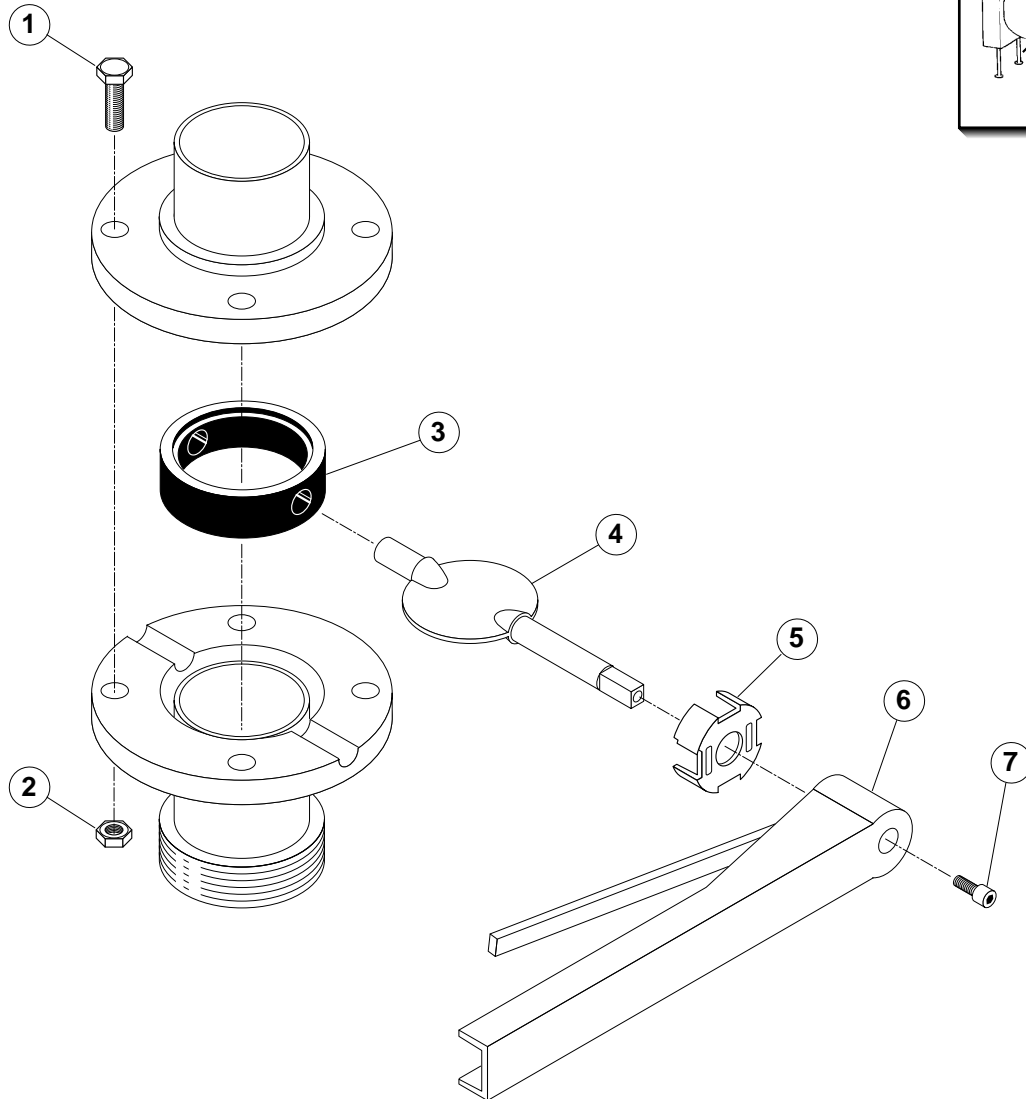
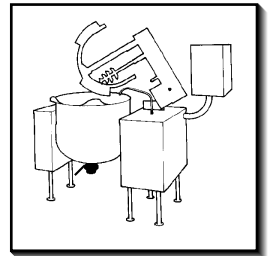

ITEM NO.	PART NO.	DESCRIPTION	QTY.
1. - 7.	KE51603	Butterfly Valve, 2" (includes housing)	1
	KE52286	Butterfly Valve, 3" (includes housing)	1
1.	FA11224	Bolt, 5/16-18x1" S.S.	4
2.	FA21024	Nut, 5/16-18	4
3.	SE50433	Seat, 2"	1
	SE50433-1	Seat, 3"	1
4.	SE50434	Stem, 2"	1
	SE50434-1	Stem, 3"	1
5.	SE50435	Locking Spider, 2"	1
	SE50435-1	Locking Spider, 3"	1
6.	SE50436	Handle Assembly	1
7.	SE50437	Allen Bolt	1

MAIN COMPONENT REFERENCE CHARTS

Valves:

KETTLE SIZE GALLONS	PRES-SURE PSI	STEAM TRAP	SAFETY VALVE	MANUAL VALVE	CHECK VALVE	STRAINER	SOLENOIDS				
							STEAM	CONDENSATE	POTABLE WATER	COOLING WATER	DUMP VALVE
40	50	1/2" NPT KE51248	3/4" x 3/4" KE51720	3/4" x 3/4" KE00350	3/4" KE51653	3/4" KE51654	3/4" x 3/4" KE51652	3/4" x 3/4" KE51656	3/4" x 3/4" KE51656	3/4" x 3/4" KE51656	3/8" x 3/8" KE52668
60-80	50	1/2" NPT KE51248	3/4" x 3/4" KE51720	3/4" x 3/4" KE00350	3/4" KE51653	3/4" KE61654	3/4" x 3/4" KE51652	3/4" x 3/4" KE51656	3/4" x 3/4" KE51656	3/4" x 3/4" KE51656	3/8" x 3/8" KE52668
100-125	35	1/2" NPT KE51248	1-1/4" x 1-1/4" KE53144	1-1/4" x 1-1/4" KE01212	1-1/4" KE51367	1-1/4" KE53008	1-1/4" x 1-1/4" KE53007	3/4" x 3/4" KE51656	3/4" x 3/4" KE51656	3/4" x 3/4" KE51656	3/8" x 3/8" KE52668
150	35	1/2" NPT KE51248	1-1/4" x 1-1/4" KE53144	1-1/4" x 1-1/4" KE01212	1-1/4" KE51367	1-1/4" KE53008	1-1/4" x 1-1/4" KE53007	3/4" x 3/4" KE51656	3/4" x 3/4" KE51656	3/4" x 3/4" KE51656	3/8" x 3/8" KE52668
200-250	35	1/2" NPT KE51248	1-1/4" x 1-1/4" KE53144	1-1/4" x 1-1/4" KE01212	1-1/4" KE51367	1-1/4" KE53008	1-1/4" x 1-1/4" KE53007	3/4" x 3/4" KE51656	3/4" x 3/4" KE51656	3/4" x 3/4" KE51656	3/8" x 3/8" KE52668
40	100	1/2" NPT KE53160	3/4" x 1" KE53158	3/4" x 3/4" KE00350	3/4" KE51653	3/4" KE61654	3/4" x 3/4" KE53159	3/4" x 3/4" KE53159	3/4" x 3/4" KE51656	3/4" x 3/4" KE53159	3/8" x 3/8" KE52668
60-80	100	1/2" NPT KE53160	3/4" x 1" KE53158	3/4" x 3/4" KE00350	3/4" KE51653	3/4" KE61654V	3/4" x 3/4" KE53159	3/4" x 3/4" KE53159	3/4" x 3/4" KE51656	3/4" x 3/4" KE53159	3/8" x 3/8" KE52668
100-125	100	1/2" NPT KE53160	1-1/4" x 1-1/4" KE53162	1-1/4" x 1-1/4" KE01212	1-1/4" KE51367	1-1/4" KE53008	1-1/4" x 1-1/4" KE53007	1-1/4" x 1-1/4" KE53007	3/4" x 3/4" KE51656	3/4" x 3/4" KE51656	3/8" x 3/8" KE52668
150	100	1/2" NPT KE53160	1-1/4" x 1-1/4" KE53162	1-1/4" x 1-1/4" KE01212	1-1/4" KE51367	1-1/4" KE53008	1-1/4" x 1-1/4" KE53007	1-1/4" x 1-1/4" KE53007	3/4" x 3/4" KE51656	1-1/4" x 1-1/4" KE53007	3/8" x 3/8" KE52668
200-250	100	1/2" NPT KE53160	1-1/4" x 1-1/4" KE53162	1-1/4" x 1-1/4" KE01212	1-1/4" KE51367	1-1/4" KE53008	1-1/4" x 1-1/4" KE53007	1-1/4" x 1-1/4" KE53007	3/4" x 3/4" KE51656	1-1/4" x 1-1/4" KE53007	3/8" x 3/8" KE52668

Mechanical:

KETTLE SIZE GALLONS	PRESSURE PSI	GEAR SIZE	TILT	HYDRAULIC MOTORS	
				STANDARD	PRIMARY SECONDARY
40	50	KE00151 (SMALL)	MANUAL	KE51846	KE51845
60-80	50	KE00151 (SMALL)	MANUAL	KE51938	KE51845
100-125	35	KE52833 (BIG)	MANUAL	KE51938	KE51845
150	35	KE52833 (BIG)	POWER	KE51938	KE51845
200-250	35	KE52833 (BIG)	POWER	KE53004	KE53005
40	100	KE00151 (SMALL)	MANUAL	KE51846	KE51845
60-80	100	KE00151 (SMALL)	MANUAL	KE51938	KE51845
120-125	100	KE52833 (BIG)	MANUAL	KE51938	KE51845
150	100	KE52833 (BIG)	POWER	KE51938	KE51845
200-250	100	KE52833 (BIG)	POWER	KE53004	KE53005

Scraper Blades:



KETTLE SIZE GALLONS	QUANTITY
40	22
60	26
80	30
100	34
125	38
150	38
200	44
250	48

MAINTENANCE

INSPECTION AND MAINTENANCE CHECK LIST

Cleveland Range equipment requires little preventative maintenance. We do however provide the following chart as a guide line for inspection and maintenance to keep your unit functioning at 100%.

MONTHLY INSPECTIONS

Item	Inspection
Item Switches	Inspect switches for damage and correct operation. Replace as required.
<u>Product Drain Valves</u>	
Tangent Draw-Off Valve	Inspect parts for damage. Test valve for leakage. Replace as required.
Butterfly Valve.	Inspect parts for damage. Test valve for leakage. Replace as required.
Air Valve	Inspect parts for damage. Test valve for leakage. Check valve seals for air leakage. Inspect supply hose and fittings. Replace as required. Inspect air filter and replace if required.

SIX MONTH MAINTENANCE

Lubrication	Grease trunnion housings. Grease bridge swivel assembly. Use "Never Seize" on tilt worm and gear.
Strainers	Clean strainers in steam in and cooling water supply lines.

YEARLY MAINTENANCE

Lubrication	Drain hydraulic oil and remove filter. Replace oil and filter (see Hydraulic Oil Replacement Procedure.
Solenoid Valves	Inspect solenoid valves for proper operation. Clean or replace as required.

WARRANTY

Our Company supports a worldwide network of Maintenance and Repair Centers. Contact your nearest Maintenance and Repair Centre for replacement parts, service, or information regarding the proper maintenance and repair of your cooking equipment

In order to preserve the various agency safety certification (UL, NSF, ASME/Ntl. Bd., etc.), only factory-supplied replacement parts should be used. The use of other than factory supplied replacement parts will void warranty.

MRC 7000 ENABLE MODE PROCEDURE (1&2 PEN)

Reference page #36 in the MRC 7000 Installation, Wiring, Operation Manual, Form 2877, Edition 6, May 1994 update.

To prevent tampering, your programmer comes from the factory with the programming modes turned "**oFF**".

If adjustment is required then the modes must be turned "**ON**" before they are accessible. We recommend that when the adjustments have been completed you turn off the programming modes again.

To turn on the mode required perform the following steps:

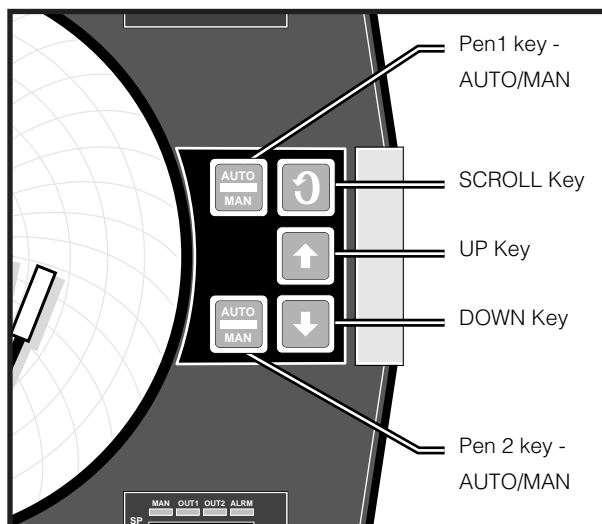

CAL 9900 Controls Drawing

1. Turn MAIN POWER SWITCH to "ON".
2. Press the scroll key "⤵" until "**Ctrl**" is displayed.
3. Press and hold the "↑" and "↓" keys at the same time. All the display lamps will light.
4. After 10 seconds the display lights will go out and "**EnAb**" will be displayed. Release the "↑" and "↓" keys. "**EtSt**" will appear.
5. Repeatedly press the "↓" key until the desired mode is displayed.
6. Press the scroll key "⤵" once to display the mode's setting ("**ON**" or "**oFF**").
7. Press the "↑" key to turn the desired mode "**ON**".
8. To turn desired mode "**oFF**" follow steps 1-5 and then press "↓" key.

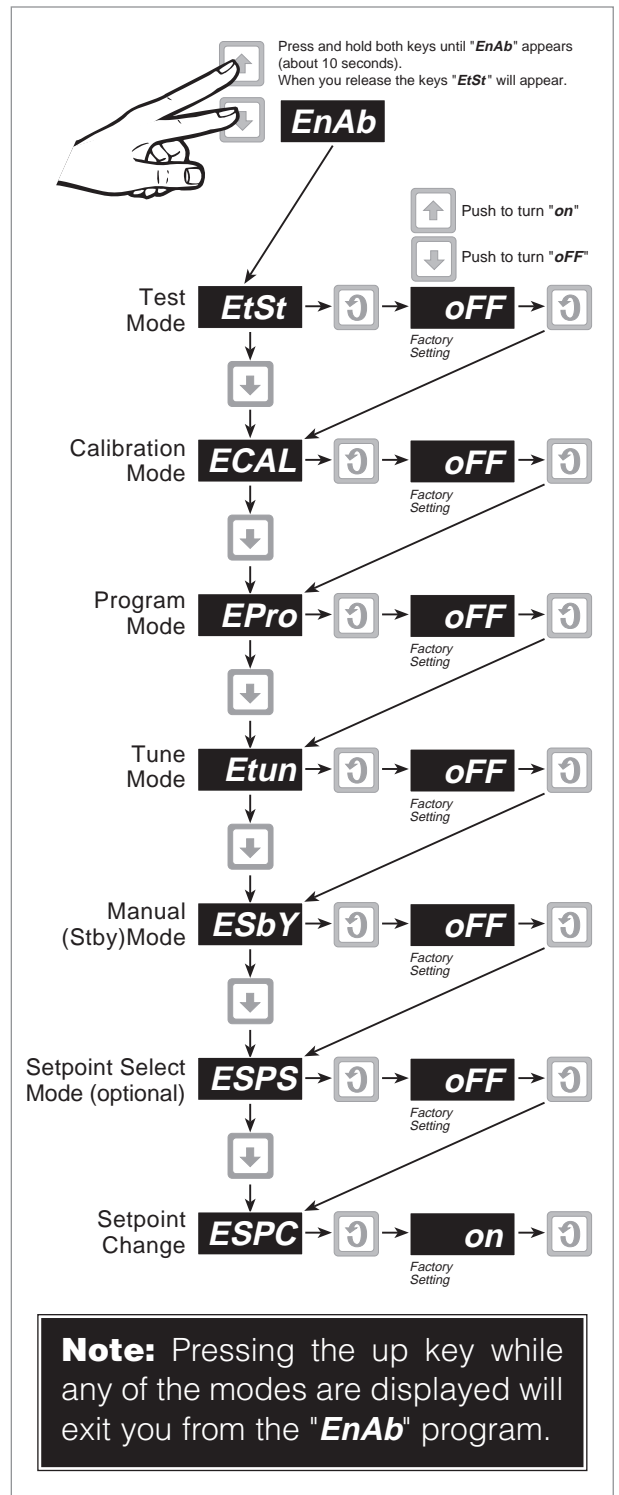

MRC 7000 Enable Mode Flow Chart

AIR LINE LUBRICATOR OIL FILLING PROCEDURE

1. Disconnect air supply and bleed system.
2. Remove cover on console (see PARTS LIST - PNEUMATIC COMPONENTS).
3. Check for oiler location.

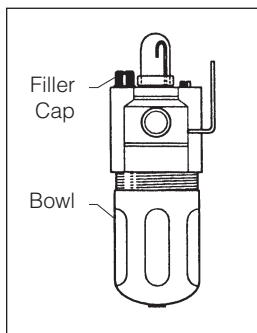

Oiler

4. Inspect oil level in bowl.
5. Remove filler cap.
6. Add mineral oil as required.
7. Replace filler cap and console cover.

AIR FILTER REPLACEMENT PROCEDURE

1. Disconnect air supply and bleed system.
2. Remove cover on console (see Parts List - Pneumatic Components).
3. Check for filter location.

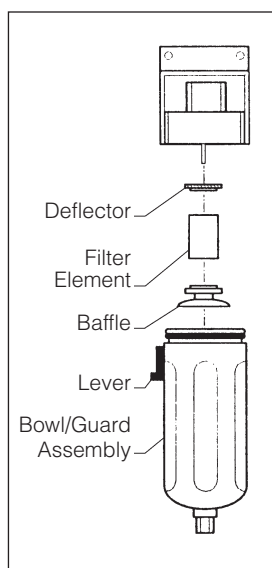

Air Filter

4. Push lever down and rotate bowl/guard assembly 1/8 turn.
5. Push down on bowl/guard assembly and remove.
6. Unscrew baffle and remove filter element, inspect and replace filter if required.
7. Replace filler cap and cover.

AUTOMATIC DUMP VALVE

Replacing "O" rings (8):

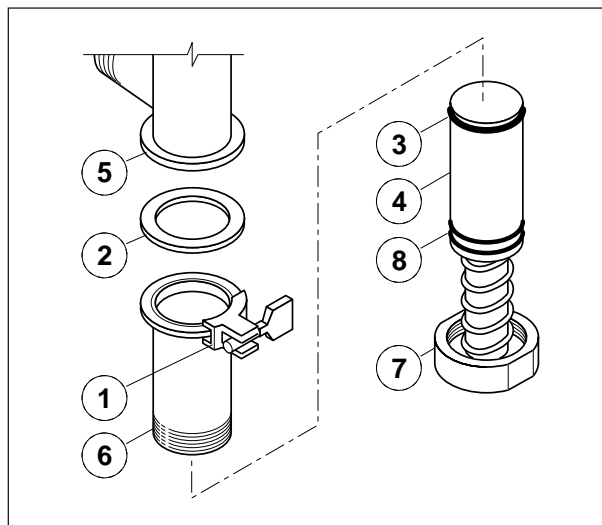

Automatic Dump Valve

1. Disassemble valve as per daily cleaning instructions.
2. Holding lower valve body (6), unscrew valve bottom (7).
3. Pull lower valve body out from cylinder body.
4. Replace "O" rings (8), as required.
5. Coat cylinder body and "O" rings with cooking oil or food-safe grease.
6. Reassemble.

STEAM TRAP

Each kettle is equipped with a steam trap in the line of the kettle outlet to the drain, to remove line condensate that forms inside the steam jacket. A good steam trap at startup releases air and wet steam into the drain line for a few minutes, then holds the steam jacket. During cooking, the trap periodically releases accumulated condensate. If the kettle's cooking performance becomes inadequate after long use, replacement of the steam trap with a new one may restore kettle operation to peak efficiency.

RE-INSTALLING SPEED CONTROL CABLE

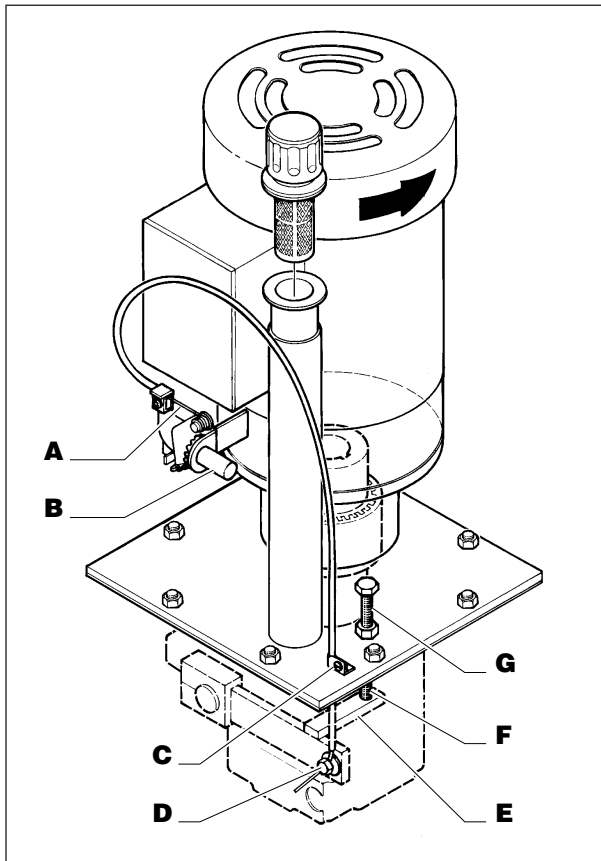

Speed Control Assembly

1. Turn sprocket of speed control so that wire "A" is fully extended towards shaft "B".
2. Insert end of cable through bracket "C".
3. Insert wire so it protrudes approximately 1/2" to 5/8" through hole in bolt "D". Tighten bolt and bend end of wire.
4. Bring pump arm "E" up until it hits stop bolt "F" and tighten screw "C".
5. Reassemble unit. Speed control knob will go on pointing toward minimum setting.
6. Turn mixer on with speed control set at minimum setting.
7. If scraper arm is turning, loosen nut "G" and back stop bolt "F" off a few turns. Next loosen screw "C" and slowly pull up cable until scraper arm stops turning. Retighten screw "C". Gently turn stop bolt "F" down until it hits arm. Lock in place by tightening nut "G".
8. Scraper arm should now go from no rotation to fast rotation by turning speed control knob.

NOTE: Mixer may run rough and noisy for one or two hours if air has become trapped in the line.

HYDRAULIC OIL REPLACEMENT PROCEDURE

One of the most important maintenance tasks is to change the hydraulic oil yearly. Under heavy usage the oil should be changed every nine months. It is important to change the oil regularly to prevent its breakdown which leads to the damaging of components.

The oil filter should be changed at the same time as the hydraulic oil. A clean filter prevents particles from damaging the other components in the system.

Replace the hydraulic fluid as follows:

- ⇒ Disconnect power to unit.
- ⇒ Remove the front top panel on the main console.
- ⇒ Remove chrome vent cap from breather pipe located beside electric motor.
- ⇒ Remove plug bolt from bottom left front corner of main console to drain oil into your catch pail.
- ⇒ Remove oil filter.
- ⇒ Replace plug bolt.
- ⇒ Refill unit through breather pipe using approximately 12 U.S. gallons of Tellus 32 hydraulic oil (oil should be 6 1/2" deep in tank).
- ⇒ Install new oil filter (Part# SE50094).
- ⇒ Replace chrome vent cap and front top panel.
- ⇒ Reconnect power to unit.
- ⇒ Run unit to remove any air in the lines.

NOTE: Mixer may run rough and noisy for one or two hours if air has become trapped in the line.

LUBRICATION

Lubricate the following parts every three months to insure smooth operation and reduce wear.

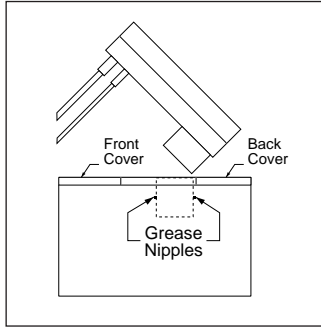

Side View of 18" Console

MIXER BRIDGE HOUSING

There are two grease nipples on the mixer bridge swivel housing which are accessed by removing the front and back covers on the 18" console.

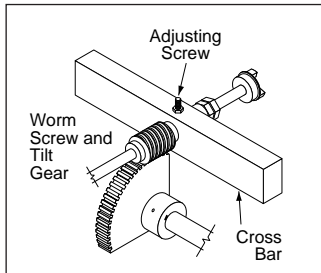

Trunnion and Tilt Mechanism Drawing

TRUNNION HOUSING, WORM SCREW AND TILT GEAR

These parts are accessed through the front cover on the 18" console.

Apply grease to gear teeth. Check for excessive play and adjust with adjusting screw located on top of cross bar.

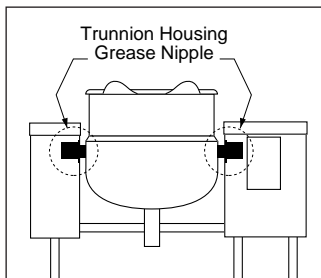

Kettle Trunnion Drawing

KETTLE TRUNNIONS

Accessed via the top covers on the 10" and 18" consoles. Each has two grease nipples.

DISASSEMBLY OF SWITCH ASSEMBLY

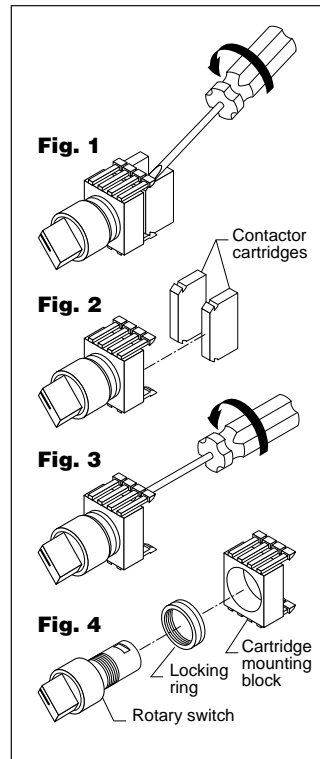

Switch Assembly

1. Place slotted screwdriver between contactor cartridge and cartridge mounting block as shown in **Fig.1**.
2. Twist screwdriver to free cartridge.
3. Place screwdriver under tab in the back of the cartridge mounting block as shown in **Fig. 3**.
4. Twist screwdriver to remove block from the rotary switch.
3. Unscrew locking ring to remove rotary switch.

SOLENOID VALVE MAINTENANCE

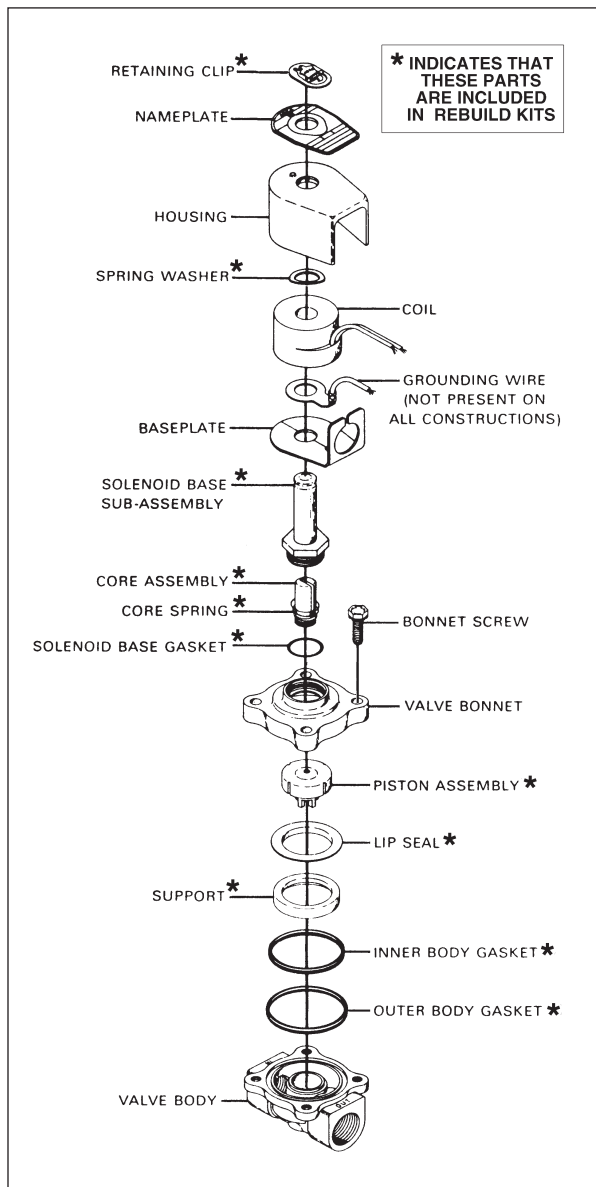

Solenoid Valve Exploded View Drawing

Ordering Information

Parts marked with an asterisk (*) in the Solenoid Valve Exploded View Drawing are supplied in the Rebuild Kits.

Valve# (Description)	Rebuild Kit#	Replacement Coil#
CT50182 (2", 120V/60 Hz.)	SE50400	SE50401
CT50244 (1", 120V/60 Hz.)	SE50402	SE50401
CT50245 (1", 120V/60 Hz.)	SE50403	SE50404
KE51652 (3/4", 120V/60 Hz.)	SE50405	SE50406
KE51656 (3/4", 120V/60 Hz., HW)	SE50407	SE50401
KE52668 (3/8", 120V/60 Hz.)	SE50408	SE50404
KE53007 (1 1/4", 120V/60 Hz.)	SE50409	SE50404
KE53159 (3/4", 120V/60 Hz.)	SE50410	SE50404

NOTE: It is not necessary to remove the valve from the pipeline for repairs.

WARNING: Turn off electrical power supply and depressurize valve before making repairs.

Cleaning

All solenoid valves should be cleaned periodically. The time between cleanings will vary depending on the medium and service conditions. In general, if the voltage to the coil is correct, sluggish valve operation, excessive noise or leakage will indicate that cleaning is required. Clean valve strainer or filter when cleaning the valve.

Preventive Maintenance

1. Keep the medium flowing through the valve as free from dirt and foreign material as possible.
2. While in service, the valve should be operated at least once a month to insure proper opening and closing.
3. Depending on the medium and service conditions, periodic inspection of internal valve parts for damage or excessive wear is recommended. Thoroughly clean all parts. Replace worn or damaged parts. However, for best results, replace all parts as supplied with a Rebuild Kit.

Causes of Improper Operation

1. **Faulty Control Circuits:** Check the electrical system by energizing the solenoid. A metallic "click" signifies that the solenoid is operating. Absence of the "click" indicates loss of power supply. Check for loose or blown fuses, open circuited or grounded coil, broken lead wires or splice connections.
2. **Burned-Out Coil:** Check for open-circuited coil. Replace coil as necessary. Check supply voltage; it must be the same as specified on nameplate.
3. **Low Voltage:** Check voltage across the coil lead. Voltage must be at least 85% of nameplate rating.
4. **Incorrect Pressure:** Check valve pressure. Pressure to valve must be within range specified on nameplate.
5. **Excessive Leakage:** Disassemble valve and clean all parts. If leakage continues, replace all parts as supplied with a Rebuild Kit.

Coil Replacement

WARNING: Turn off electrical power supply.

1. Disconnect coil lead wires and green grounding wire if present.
2. Remove retaining clip, nameplate and housing.

WARNING: When metal retaining clip disengages, it will spring upward.

3. Slip spring washer and coil off the solenoid base subassembly.
4. Coil is now accessible for replacement. Reassemble in reverse order of disassembly. Use Solenoid Valve Exploded View Drawing for identification and placement of parts.

CAUTION: Solenoid must be fully reassembled because the housing and internal parts complete the magnetic circuit.

Valve Disassembly

WARNING: Depressurize valve and turn off electrical power supply.

1. Disassemble valve in an orderly fashion. Use exploded view for identification and placement of parts.
2. If necessary, disconnect coil lead wires, grounding wire (if present), and rigid conduit from solenoid housing,
3. Remove retaining clip and slip the entire solenoid enclosure off the solenoid base sub-assembly.

WARNING: When metal retaining clip disengages, it will spring upward,

4. Unscrew solenoid base sub-assembly and remove core assembly, core spring, and solenoid base gasket.
5. Remove bonnet screws, valve bonnet, piston assembly, lip seal, support, inner and outer body gaskets.
6. All parts are now accessible to clean or replace; Replace worn or damaged parts. However, for best results, replace all parts as supplied with an Rebuild Kit.

Valve Reassembly

1. Reassemble in reverse order of disassembly. Use exploded view for identification and placement of parts.
2. Lubricate all gaskets with DOW CORNING 111® Compound lubricant or an equivalent high-grade silicone grease.
3. Position support and inner and outer body gaskets in valve body.
4. Position lip seal, flanged end up, onto piston assembly. Install piston assembly with lip seal into support in valve body cavity.
5. Replace valve bonnet and bonnet screws. Torque bonnet screws in a crisscross manner to 95 ±10 inch-pounds (10,7 ±1,1 newton-meters).
6. Replace solenoid base gasket, core assembly, and solenoid base sub-assembly. Torque solenoid base sub-assembly to 175 ±25 inch-pounds (19,8 ±2,8 newton-meters).
7. Replace solenoid enclosure and retaining clip.
8. Restore line pressure and electrical power supply to valve.
9. After maintenance is completed, operate the valve a few times to be sure of proper opening and closing.

WIRING DIAGRAM

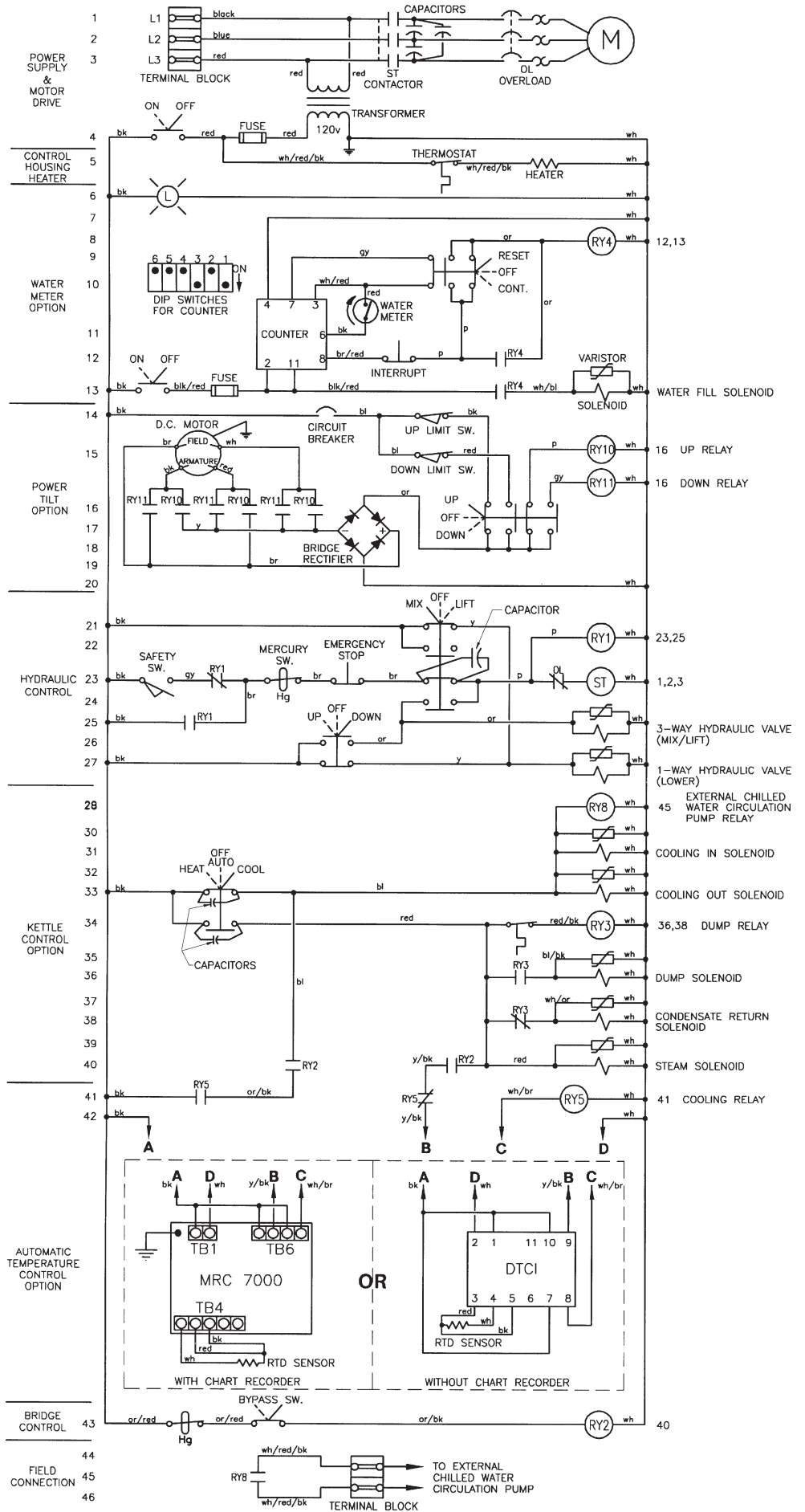

FLOW PATH FOR HYDRAULIC SYSTEM

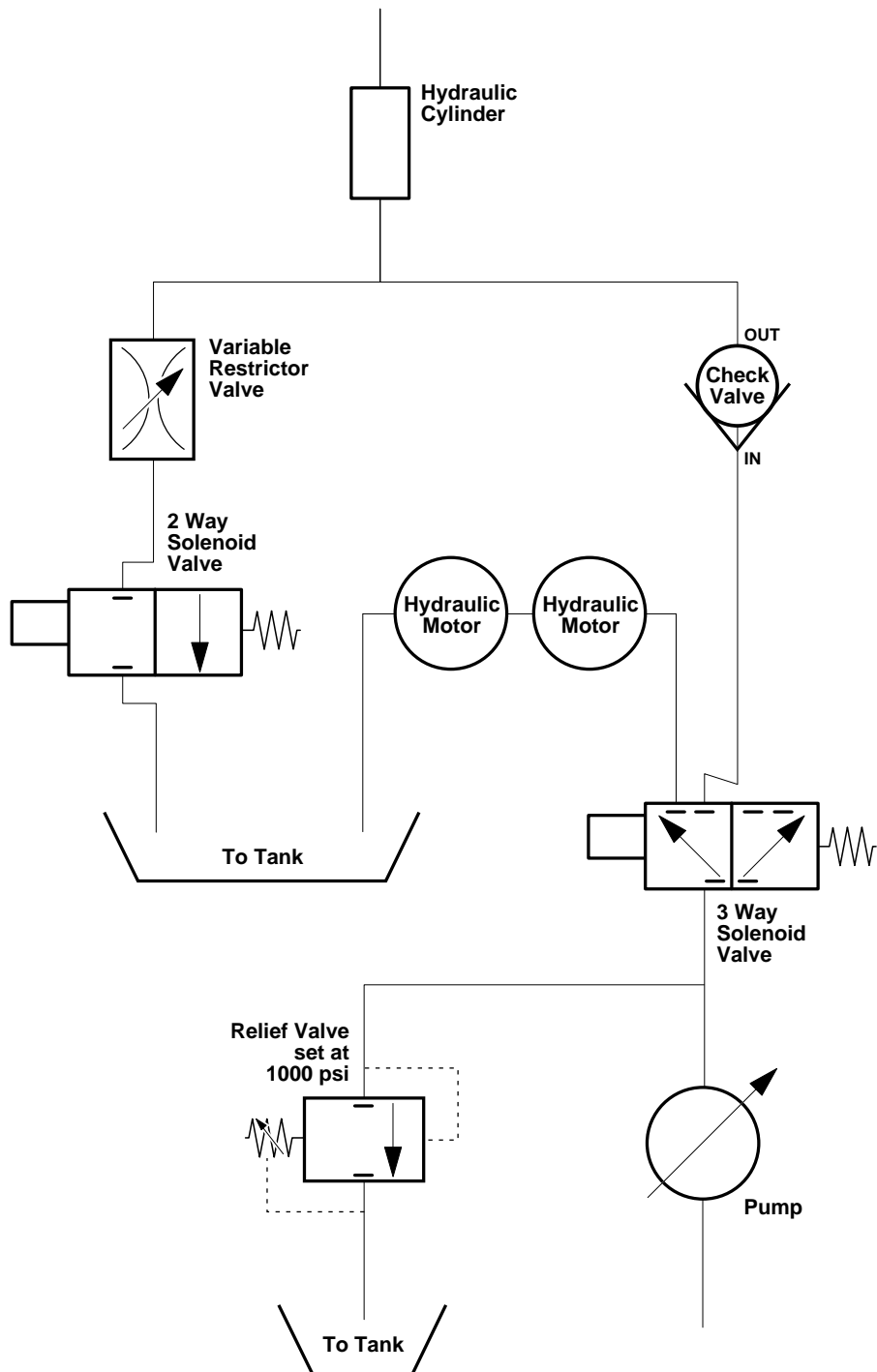

SPARE PARTS LIST

ITEM ON.	DESCRIPTION	QTY. DOMESTIC	QTY. OVERSEAS
<u>Spare Parts</u>			
SE50426	Air Filter Element	1	1
SE50428	"O" Ring for Air Filter	1	1
KE52895	Air Regulator	---	1
KE52936	Fuse	1	1
KE01808	Switch Assembly - On/Off - Maintained	---	1
KE01809	Switch Assembly - On/Off/On - Maintained	---	1
KE01810	Switch Assembly - Momentary Spring Return	---	1
KE01811	Switch Assembly - Momentary Spring Return	---	1
KE52074	Capacitor	2	2
KE53138	Capacitor Cartridge - NC	2	2
KE53138-1	Capacitor Cartridge - NO	2	2
KE50753-10	Relay	2	2
KE00860	Cable and Bracket Assembly - Speed Control	---	1
SE50224	Solenoid Valve Coil	---	1
KE53962	Blade Stop Ring	2	2
KE51834	Scraper Blades	2	2
SE50094	Oil Filter	1	1
KE51652	Solenoid Valve, 3/4" - 50 psi.	---	1
KE52668	Solenoid Valve, 3/8"	---	1
KE52701	Steam Trap	---	1
UR50077	Thermostat	---	1
KE50579	Circuit Breaker	---	1
FA00012	"O" Ring for Circuit Breaker	1	1
KE50580	Water Resistant Boot for Circuit Breaker	1	1
KE53138-1	Contact Block	---	1
FA00016	"O" Ring for Faucet Spout	2	2
SK50445	Fuse - 3 amps	1	1
SK52936	Fuse - 1 amps	1	1
KE50750-1	Contacting	---	1

FLUSH PISTON VALVE

<u>Spare Parts</u>			
FA05000	"O" Ring for Cylinder Head	5	5
KE52347	Sani-Clamp Seal - 4"	5	5
KE52344	Sani-Clamp 4"	---	1
FA00152	"O" Ring for Cylinder Body	4	4
FA00225	"O" Ring for Piston	4	4

BUTTERFLY VALVE

<u>Spare Parts</u>			
SE50433	Seat - 2"	---	1
SE50433-1	Seat - 2"	---	1