

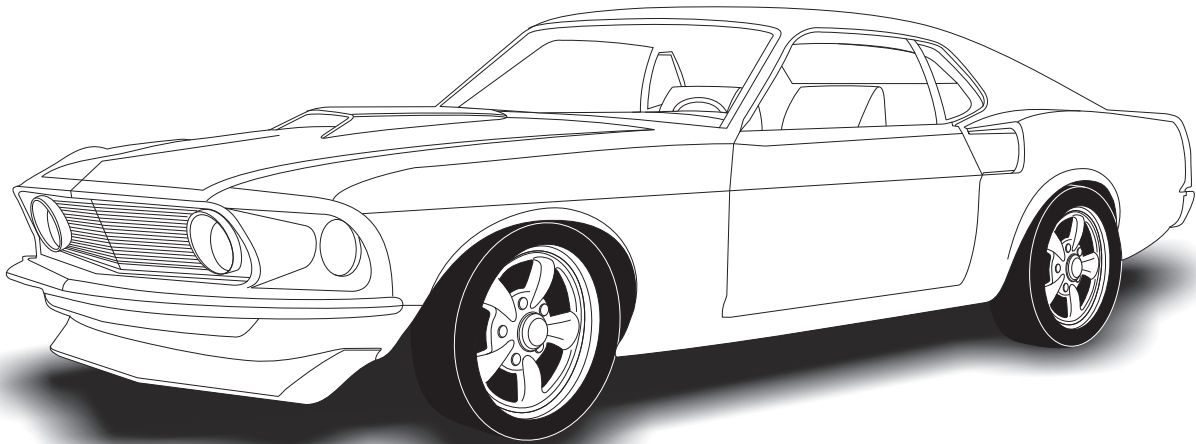

# 1969-70 MUSTANG

w/o FACTORY AIR GEN IV  
551170



18865 GOLL ST. - SAN ANTONIO, TX. - 78266 ph.210-654-7171 - fax 210-654-3113



## Table of Contents

### PAGES

1. COVER
2. TABLE OF CONTENTS
3. PACKING LIST/ PARTS DISCLAIMER
4. INFORMATION PAGE
5. WIRING NOTICE
6. ENGINE COMPARTMENT / PASSENGER COMPARTMENT  
FIGURES 1 & 2
7. DEFROST DUCT / FRESH AIR CAP & DRIVER AND PASSENGER SIDE  
LOUVER INSTALLATION  
FIGURES 3 & 4, 4a
8. EVAPORATOR INSTALLATION  
FIGURES 5, 5a & 6
9. FIREWALL COVER INSTALLATION  
FIGURES 7 & 7a
10. CENTER LOUVER INSTALLATION  
FIGURES 8 & 8a
11. DRAIN HOSE INSTALLATION & LUBRICATING O-RINGS, STANDARD HOSE KIT  
& MODIFIED A/C HOSE KIT  
FIGURES 9 & 10
12. HEATER HOSE & HEATER CONTROL VALVE INSTALLATION  
FIGURE 11
13. A/C & HEATER HOSE ROUTING  
FIGURE 12
14. FINAL STEPS & GLOVE BOX INSTALLATION  
FIGURES 13 & 13a
15. DUCT HOSE ROUTING  
FIGURE 14
16. EVAPORATOR HARD LINE AND BRACKET INSTALLATION  
FIGURE 15
17. WIRING DIAGRAM
18. GEN IV WIRING CONNECTION INSTRUCTIONS
19. OPERATION OF CONTROLS.
20. TROUBLE SHOOTING
21. TROUBLE SHOOTING CONT.
22. DRIVER SIDE LOUVER TEMPLATE
23. PASSENGER SIDE LOUVER TEMPLATE
24. CENTER LOUVER TEMPLATE
25. FIREWALL COVER HOLE TEMPLATE
26. EVAPORATOR KIT PACKING LIST



**EVAPORATOR KIT PACKING LIST**

**EVAPORATOR KIT  
551170**

No.	QTY.	PART No.	DESCRIPTION
1.	1	763069	69-70 MUSTANG EVAP. SUB CASE
2.	1	781069	1969-70 MUSTANG w/o AC ACC. KIT

**\*\* BEFORE BEGINNING INSTALLATION OPEN ALL PACKAGES AND CHECK CONTENTS OF SHIPMENT. PLEASE REPORT ANY SHORTAGES DIRECTLY TO VINTAGE AIR WITHIN 15 DAYS. AFTER 15 DAYS, VINTAGE AIR WILL NOT BE RESPONSIBLE FOR MISSING OR DAMAGED ITEMS.**

①

**69-70 MUSTANG  
EVAP. SUB CASE  
763069**

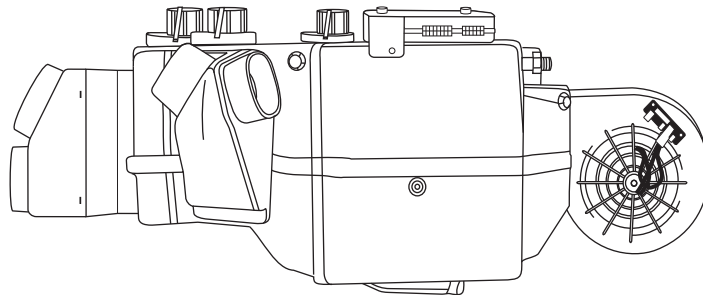

②

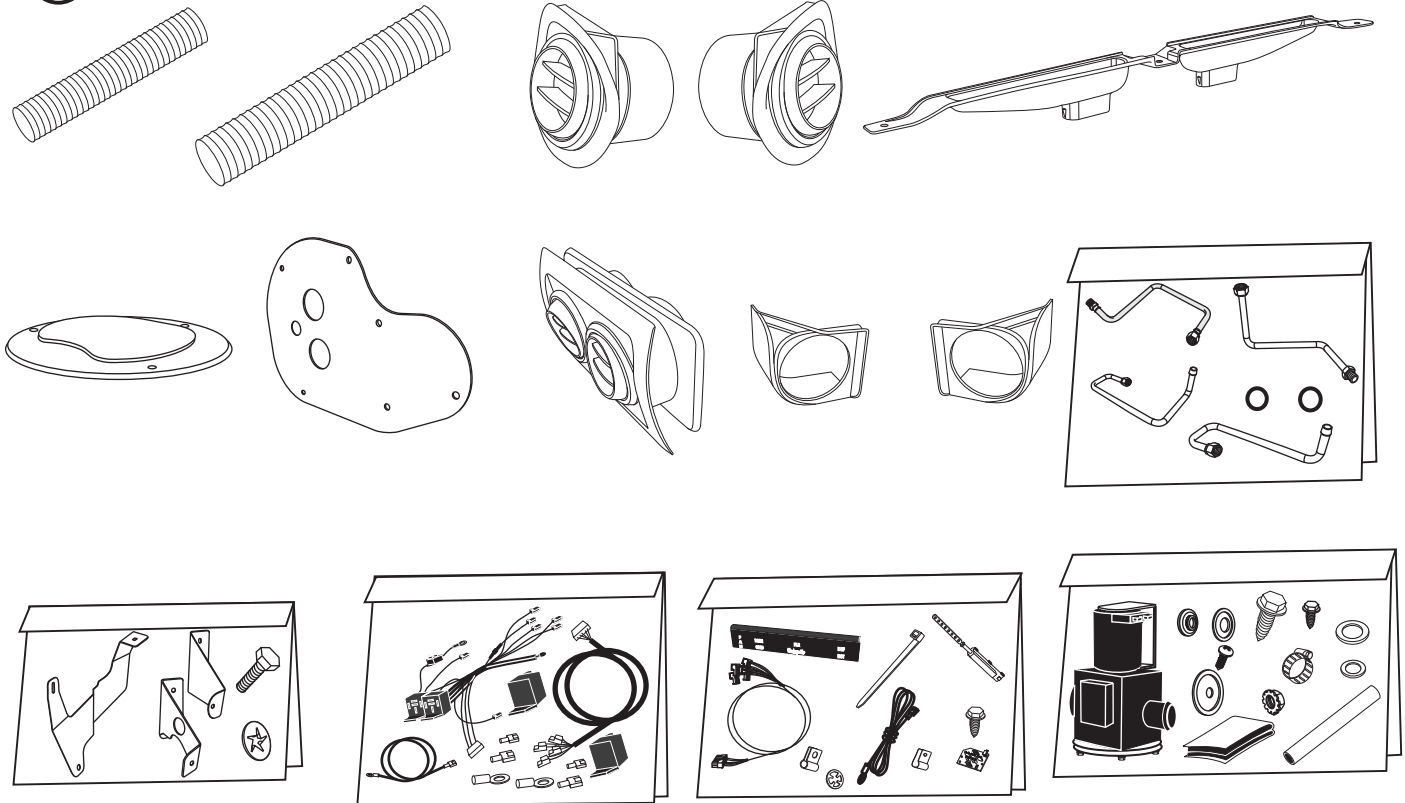

**ACCESSORY KIT  
781069**

**NOTE: IMAGES MAY NOT DEPICT ACTUAL PARTS AND QUANTITIES. REFER TO PACKING LIST FOR ACTUAL PARTS AND QUANTITIES**



1969-70 MUSTANG w/o AC GEN IV

# 1969-70 MUSTANG w/o FACTORY AIR

## IMPORTANT NOTICE-PLEASE READ

**FOR MAXIMUM SYSTEM PERFORMANCE VINTAGE AIR RECOMMENDS THE FOLLOWING:**

**THIS KIT DOES NOT CONTAIN HEATER HOSE. YOU MUST PURCHASE 8 FEET OF 5/8" DIA. HEATER HOSE FROM VINTAGE AIR(31800-VUD) OR FROM YOU LOCAL PARTS RETAILER**

### **SAFETY SWITCHES:**

YOUR VINTAGE AIR SYSTEM IS EQUIPPED WITH A BINARY PRESSURE SAFETY SWITCH. A BINARY SWITCH (11078-VUS) DISENGAGES THE COMPRESSOR CLUTCH IN CASE OF EXTREME LOW PRESSURE CONDITION (REFRIGERANT LOSS) OR EXCESSIVELY HIGH HEAD PRESSURE (406 PSI), TO PREVENT COMPRESSOR DAMAGE OR HOSE RUPTURE. A TRINARY SWITCH (11076-VUS) COMBINES HI/LO PRESSURE PROTECTION WITH AN ELECTRIC FAN OPERATION SIGNAL AT 254 PSI., AND MAY BE SUBSTITUTED FOR USE WITH ELECTRIC CONDENSER FANS. COMPRESSOR SAFETY SWITCHES ARE EXTREMELY IMPORTANT SINCE AN A/C SYSTEM RELIES ON REFRIGERANT TO CARRY LUBRICATION THROUGH THE SYSTEM.

### **SERVICE INFO:**

**ATTENTION:** SYSTEM COMPONENTS: THE COMPRESSOR, EVAPORATOR, CONDENSER & DRIER ARE CAPPED. CAPS MAY BE UNDER PRESSURE WITH DRY NITROGEN; BE CAREFUL REMOVING CAPS. DO NOT REMOVE CAPS PRIOR TO INSTALLATION. REMOVING CAPS PRIOR TO INSTALLATION WILL CAUSE COMPONENTS TO COLLECT MOISTURE AND LEAD TO PREMATURE FAILURE AND REDUCED PERFORMANCE.

EVACUATE THE SYSTEM FOR 35-45 MINUTES WITH SYSTEM COMPONENTS (DRIER, COMPRESSOR, EVAPORATOR AND CONDENSER) AT A TEMPERATURE OF AT LEAST 85° F. ON A COOL DAY THE COMPONENTS CAN BE HEATED WITH A HEAT GUN OR BY RUNNING THE ENGINE WITH THE HEATER ON BEFORE EVACUATING. LEAK CHECK AND CHARGE TO SPECIFICATIONS.

**VINTAGE AIR SYSTEMS ARE DESIGNED TO OPERATE WITH R134a or R-12 REFRIGERANT ONLY ! USE OF ANY OTHER REFRIGERANTS RISKS A DANGER OF FIRE AND COULD DAMAGE EITHER YOUR AIR CONDITIONING SYSTEM OR YOUR VEHICLE.**

**USE OF ANY OTHER REFRIGERANTS WILL VOID ALL WARRANTIES OF THE AIR CONDITIONING SYSTEM AND COMPONENTS. USE OF THE PROPER TYPE AND AMOUNT OF REFRIGERANT IS CRITICAL TO PROPER SYSTEM OPERATION. VINTAGE AIR RECOMMENDS OUR SYSTEMS BE CHARGED BY WEIGHT WITH A QUALITY CHARGING STATION OR SCALE.**

### **REFRIGERANT CAPACITIES FOR VINTAGE AIR SYSTEMS**

(FOR OTHER SYSTEMS, CONSULT MANUFACTURER GUIDELINES)

#### **134a SYSTEM**

CHARGE WITH 1.8 lbs.  
(1lbs. 12ozs) OF REFRIGERANT

#### **R-12 SYSTEM**

CHARGE WITH 2.0 lbs. OF REFRIGERANT

**LUBRICANT CAPACITIES:** NEW COMPRESSOR - NO ADDITIONAL OIL NEEDED  
USED COMPRESSOR - CONSULT VINTAGE AIR



## IMPORTANT WIRING NOTICE-PLEASE READ

SOME VEHICLES MAY HAVE HAD SOME OR ALL OF THEIR RADIO INTERFERENCE CAPACITORS REMOVED. THERE SHOULD BE A CAPACITOR FOUND AT EACH OF THE FOLLOWING LOCATIONS:

- 1. ON THE POSITIVE TERMINAL OF THE IGNITION COIL**
- 2. IF THERE IS A GENERATOR, ON THE ARMATURE TERMINAL OF THE GENERATOR**
- 3. IF THERE IS A GENERATOR, ON THE BATTERY TERMINAL OF THE VOLTAGE REGULATOR**

MOST ALTERNATORS HAVE A CAPACITOR INSTALLED INTERNALLY TO ELIMINATE WHAT IS CALLED 'WHINING' AS THE ENGINE IS REVVED. IF WHINING IS HEARD IN THE RADIO, OR JUST TO BE EXTRA CAUTIOUS, A RADIO INTERFERENCE CAPACITOR CAN BE ADDED TO THE BATTERY TERMINAL OF THE ALTERNATOR.

IT IS ALSO IMPORTANT THAT THE BATTERY LEAD IS IN GOOD SHAPE AND THAT THE GROUND LEADS ARE NOT COMPROMISED. THERE SHOULD BE A HEAVY GROUND FROM THE BATTERY TO THE ENGINE BLOCK, AND ADDITIONAL GROUNDS TO THE BODY AND TO THE CHASSIS.

IF THESE PRECAUTIONS ARE NOT OBSERVED, IT IS POSSIBLE FOR VOLTAGE SPIKES TO BE PRESENT ON THE BATTERY LEADS. THESE SPIKES COME FROM IGNITION SYSTEMS, CHARGING SYSTEMS, AND FROM TURNING SOME OF THE VEHICLE'S OTHER SYSTEMS ON AND OFF. MODERN COMPUTER OPERATED EQUIPMENT CAN BE SENSITIVE TO VOLTAGE SPIKES ON THEIR POWER LEADS, WHICH CAN CAUSE UNEXPECTED RESETS, STRANGE BEHAVIOR, AND MAY ALSO CAUSE PERMANENT DAMAGE.

VINTAGE AIR STRIVES TO HARDEN THEIR PRODUCTS AGAINST THESE TYPES OF ELECTRICAL NOISE, BUT THERE IS A POINT WHERE A VEHICLE'S ELECTRICAL SYSTEM CAN BE DEGRADED SO MUCH THAT NOTHING CAN HELP.

RADIO INTERFERENCE CAPACITORS SHOULD BE AVAILABLE AT MOST AUTO & TRUCK PARTS SUPPLIERS. THEY TYPICALLY ARE CYLINDRICAL IN SHAPE, A LITTLE OVER AN INCH LONG, A LITTLE OVER A HALF INCH IN DIAMETER, THEY HAVE A SINGLE LEAD COMING FROM ONE END OF THE CYLINDER WITH A TERMINAL ON THE END OF THE WIRE, AND THEY WILL HAVE A MOUNTING CLIP WHICH IS SCREWED INTO A GOOD GROUND ON THE VEHICLE. THE SPECIFIC VALUE OF THE CAPACITANCE IS NOT TOO SIGNIFICANT, IN COMPARISON TO IGNITION CAPACITORS THAT ARE MATCHED WITH THE COIL TO REDUCE PITTING OF THE POINTS.

- CARE MUST BE TAKEN WHEN INSTALLING THE COMPRESSOR LEAD, NOT TO SHORT IT TO GROUND. THE COMPRESSOR LEAD MUST NOT BE CONNECTED TO A CONDENSER FAN OR ANY OTHER AUXILIARY DEVICE. SHORTING TO GROUND OR CONNECTING TO A CONDENSER FAN OR ANY OTHER AUXILIARY DEVICE WILL CAUSE SEVERE DAMAGE TO THE ECU.
- WHEN INSTALLING GROUND LEADS ON GEN IV SYSTEMS, THE BLOWER CONTROL GROUND AND ECU GROUND MUST BE CONNECTED DIRECTLY TO THE NEGATIVE BATTERY POST.
- THE HEATER CONTROL VALVE IS A NORMALLY OPEN VALVE. IT MUST BE CONNECTED TO THE ECU TO BLOCK WATER FLOW IN AC MODE.



# 1969-70 MUSTANG w/o AC GEN IV

**BEFORE STARTING THE INSTALLATION, CHECK THE FUNCTION OF THE VEHICLE (HORN, LIGHTS, ETC.) FOR PROPER OPERATIONS. STUDY THE INSTRUCTIONS, ILLUSTRATIONS, & DIAGRAMS.**

## ENGINE COMPARTMENT

### REMOVE THE FOLLOWING:

- BATTERY (RETAIN).
- DRAIN RADIATOR
- HEATER HOSES(DISCARD).

### CONDENSER ASSEMBLY & INSTALLATION

- REFER TO SEPARATE INSTRUCTIONS INCLUDED WITH THE CONDENSER KIT TO INSTALL THE CONDENSER.
- BINARY SWITCH INSTALLATION ( REFER TO CONDENSER INSTRUCTIONS)

### COMPRESSOR & BRACKETS

- REFER TO SEPARATE INSTRUCTIONS INCLUDED WITH THE BRACKET KIT TO INSTALL THE COMPRESSOR BRACKET.

## PASSENGER COMPARTMENT

**NOTE:** REMOVAL OF DASHBOARD REQUIRED TO INSTALL THE EVAPORATOR. VINTAGE AIR RECOMMENDS THAT YOU UTILIZE THE FACTORY SERVICE MANUAL WHEN YOU DISASSEMBLE AND REASSEMBLE THE DASHBOARD.

### REMOVE THE FOLLOWING:

- REMOVE DASH PAD, INSTRUMENT PANEL, PASSENGER SIDE PANEL AND LOWER PASSENGER SIDE DASHBOARD (RETAIN SCREWS) SEE FIGURE 1.
- GLOVE BOX (RETAIN) SEE FIGURE 1.
- HEATER ASSEMBLY AND ALL RELATED DUCTING (DISCARD), RETAIN SCREWS. SEE FIGURE 2.
- CONTROL PANEL ASSEMBLY (RETAIN CONTROL PANEL) SEE FIGURE 1.
- REFER TO CONTROL PANEL CONVERSION KIT INSTRUCTIONS FOR INSTALLATION OF CONTROLS.
- REMOVE OEM DEFROST DUCT ASM SEE FIGURE 2.

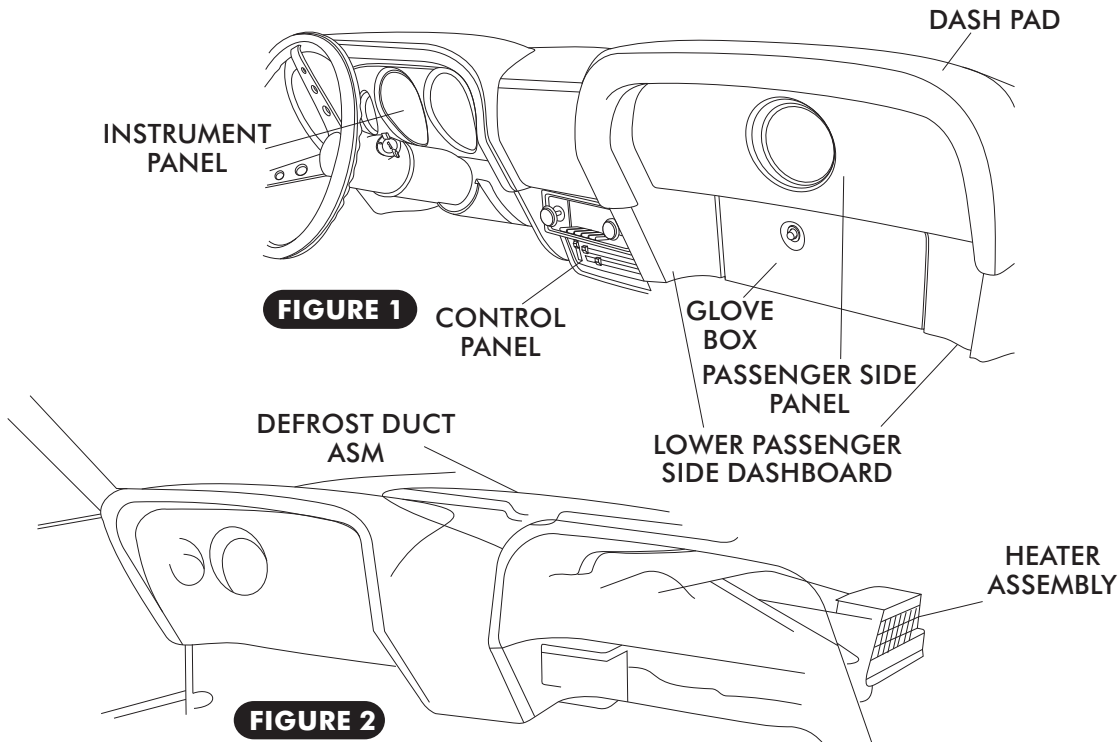

### DEFROST DUCT/ FRESH AIR CAP INSTALLATION

- INSTALL DEFROST DUCT UNDER DASH AS SHOWN IN FIGURE 3 BELOW. SECURE USING OEM NUTS w/ (3) 3/16 SAE FLAT WASHERS.
- HOLD FRESH AIR CAP UNDER DASH AND MARK THE (3) MOUNTING HOLES.
- DRILL (3) 1/8" MOUNTING HOLES UNDER DASH.
- APPLY A 1/4" BEAD OF SILICONE AROUND THE BACK SIDE OF THE FRESH AIR CAP AS SHOWN IN FIGURE 3, BELOW.
- SECURE FRESH AIR CAP TO FRESH AIR HOLE USING (3) #10 X 1/2 SHEET METAL SCREWS AS SHOWN IN FIGURE 3 BELOW.

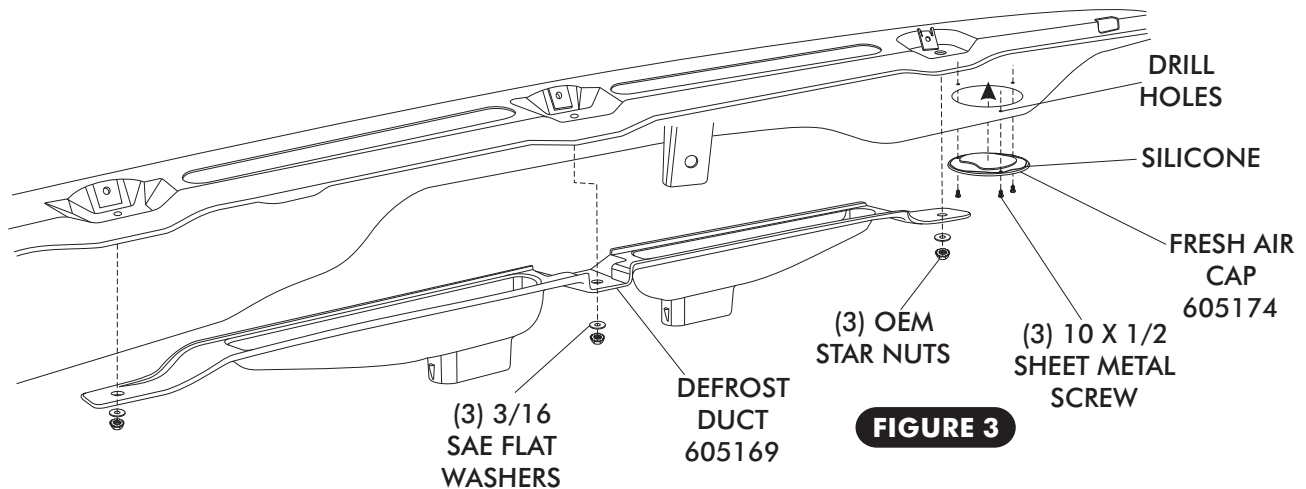

**FIGURE 3**

### DRIVER AND PASSENGER SIDE LOUVER INSTALLATION

- CUT OUT TEMPLATE PROVIDED ON PAGE 22. PLACE THE DRIVER SIDE TEMPLATE ON THE DASH BY ALIGNING THE LEFT SIDE OF THE TEMPLATE AGAINST THE EDGE OF THE DASH, THEN ALIGN THE BOTTOM OF THE TEMPLATE TO BOTTOM OF DASH AS SHOWN IN FIGURE 4.
- CUT OUT TEMPLATE PROVIDED ON PAGE 23. PLACE THE PASSENGER SIDE TEMPLATE ON THE DASH BY ALIGNING THE RIGHT SIDE OF THE TEMPLATE AGAINST THE EDGE OF THE DASH, THEN ALIGN THE BOTTOM OF THE TEMPLATE TO BOTTOM OF DASH AS SHOWN IN FIGURE 4.
- ONCE TEMPLATE IS ALIGNED CORRECTLY, USE A CENTER PUNCH TO MARK THE HOLE ON THE DASH. REMOVE TEMPLATE. USE A 2 3/4 HOLE SAW TO CUT HOLE IN DASH, SEE FIGURE 4 BELOW.
- INSTALL LOUVERS IN DASH AS SHOWN IN FIGURE 4a BELOW.

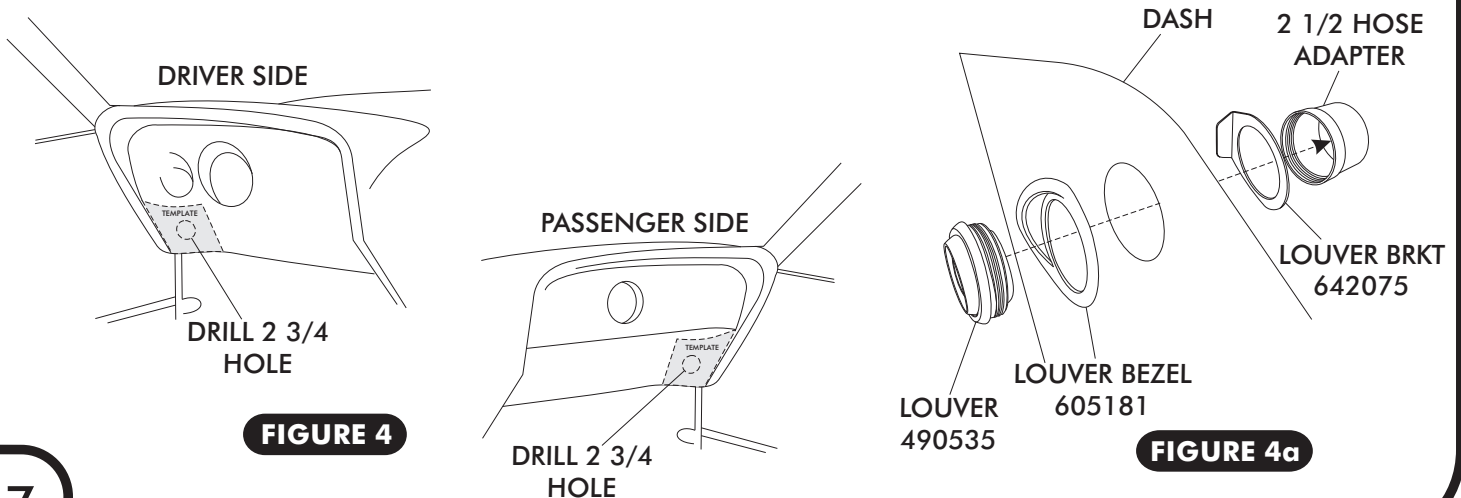

**FIGURE 4**

**FIGURE 4a**



## EVAPORATOR INSTALLATION

- USE TEMPLATE PROVIDED ON PAGE 25. ALIGN TEMPLATE WITH OEM BLOWER MOTOR MOUNTING HOLES & DRILL (6) 3/16 HOLES IN FIREWALL FROM INSIDE UNDER DASH, SEE FIGURE 5a.
- ON A WORK BENCH, INSTALL EVAPORATOR REAR BRACKET AND HARDLINES WITH PROPERLY LUBRICATED O-RINGS. (SEE FIGURE 10, PAGE 11, AND FIGURE 15, PAGE 16.)
- REMOVE 2 OEM HEATER PLUGS IN FIREWALL, SEE FIGURE 7 PAGE 9.
- INSTALL FRONT MOUNTING BRACKET ON EVAPORATOR USING (2) 1/4-20 X 1/2 HEX BOLTS AND TIGHTEN AS SHOWN IN FIGURE 5 BELOW.
- LIFT EVAPORATOR UNIT UP UNDER THE DASHBOARD SEE FIGURE 6. SECURE LOOSELY TO THE FIREWALL FROM THE ENGINE COMPARTMENT SIDE USING (2) 1/4-20 NUT AND WASHER, SEE FIGURE 6 BELOW.
- USING (2) #14 X 3/4 SHEET METAL SCREW w/ 1/4 FLAT WASHER SECURE THE FRONT EVAPORATOR MOUNTING BRACKET TO THE INNER COWL. SEE FIGURE 6 BELOW.
- VERIFY THAT EVAPORATOR UNIT IS LEVEL AND SQUARE TO THE DASH, THEN TIGHTEN ALL MOUNTING BOLTS. (**NOTE: TIGHTEN THE BOLT ON FIREWALL FIRST, THEN THE FRONT MOUNTING BRACKET SCREWS.**)

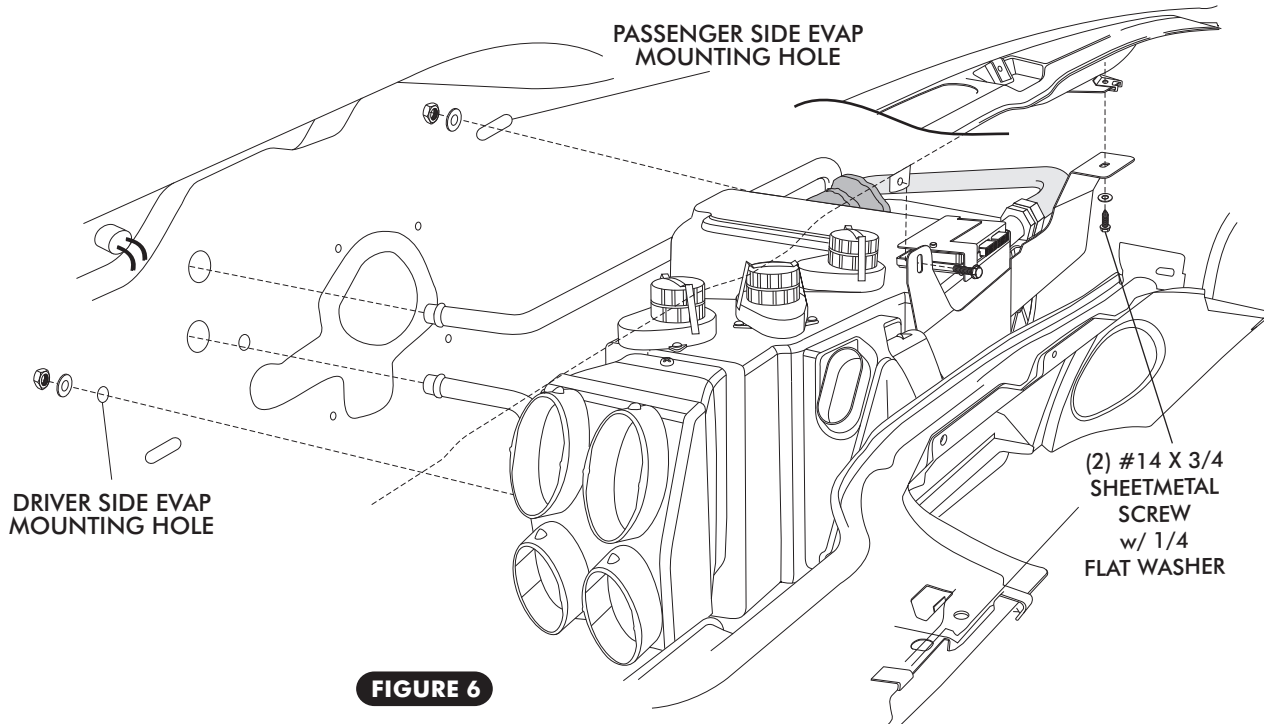
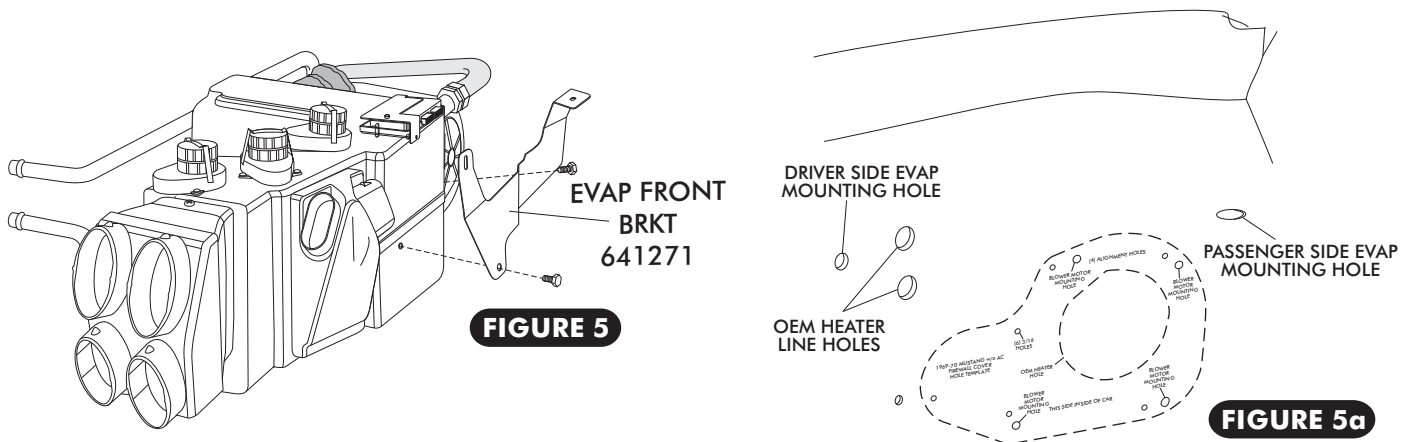

**FIGURE 6**





**FIREWALL COVER INSTALLATION**

- INSTALL (3) GROMMETS ON FIREWALL COVER AS SHOWN IN FIGURE 7, BELOW.
- APPLY A 1/4 BEAD OF SILICONE AROUND THE BACK SIDE OF THE FIREWALL COVER AS SHOWN IN FIGURE 7a, BELOW.
- SECURE FIREWALL COVER TO FIREWALL USING (6) #14 X 3/4 SHEET METAL SCREWS, SEE FIGURE 7, BELOW. (NOTE: FIREWALL COVER INSTALLS ON ENGINE SIDE OF FIREWALL.)

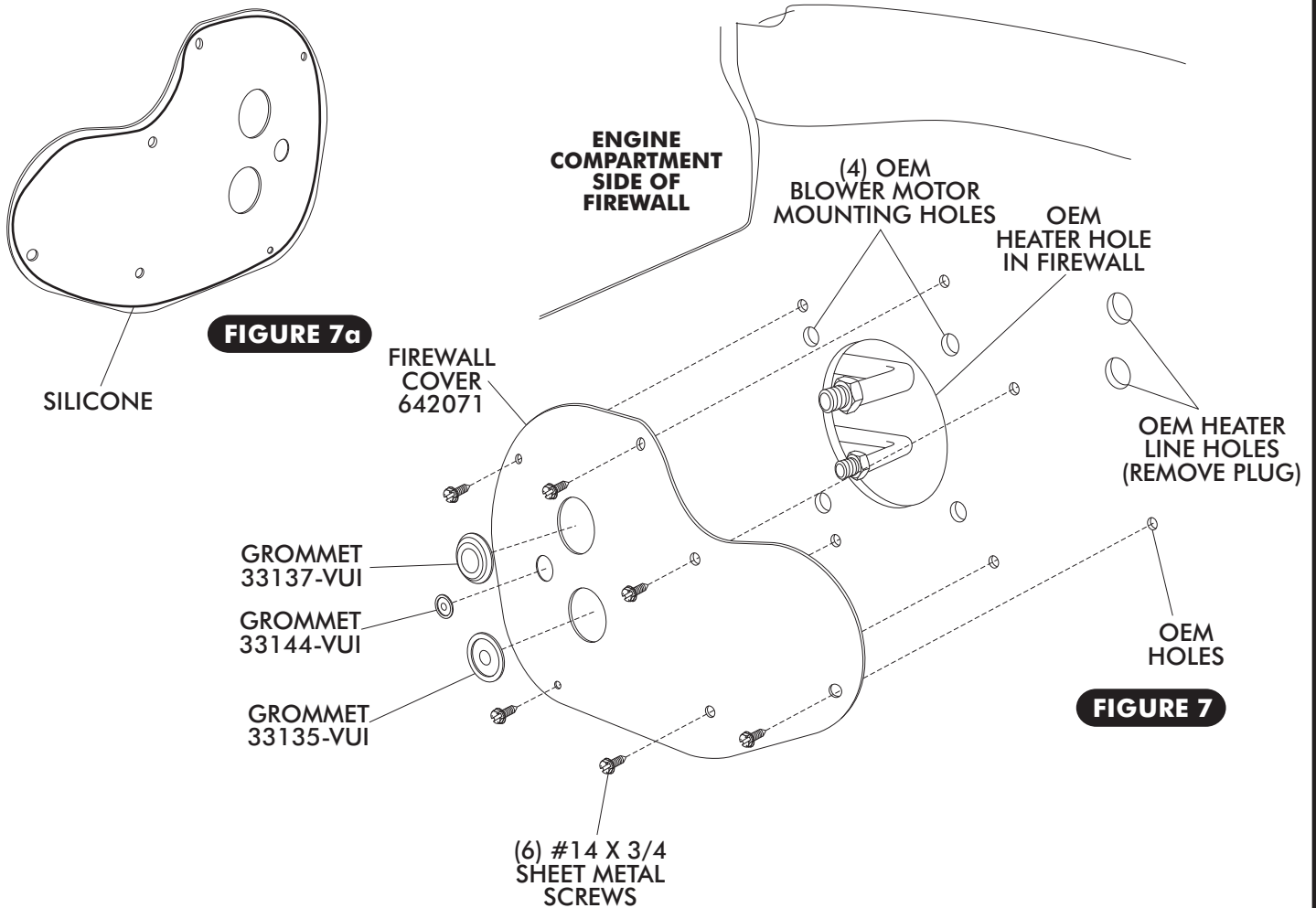



### CENTER LOUVER INSTALLATION (OPTION 1)

- CUT OUT CENTER LOUVER TEMPLATE PROVIDED ON PAGE 24. ALIGN CENTER LOUVER TEMPLATE ON DASH PAD AS SHOWN IN FIGURE 8a.
- MARK CENTER LOUVER OPENING ON DASH PAD. ONCE CENTER LOUVER OPENING IS MARKED REMOVE TEMPLATE AND CAREFULLY CUT OUT OPENING IN DASH PAD.
- INSTALL CENTER LOUVER ASM AS SHOWN IN FIGURE 8.

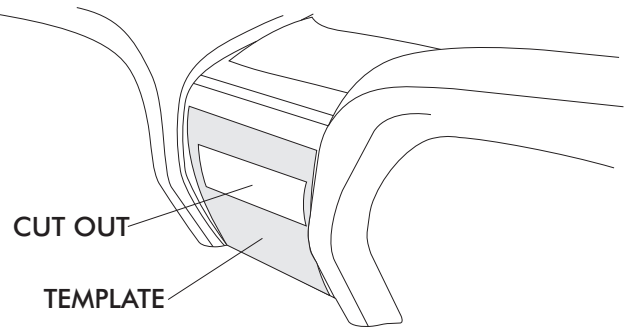

FIGURE 8a

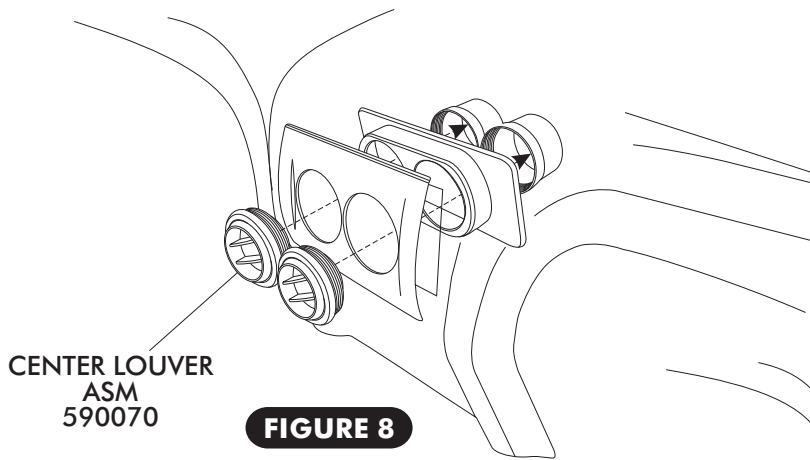
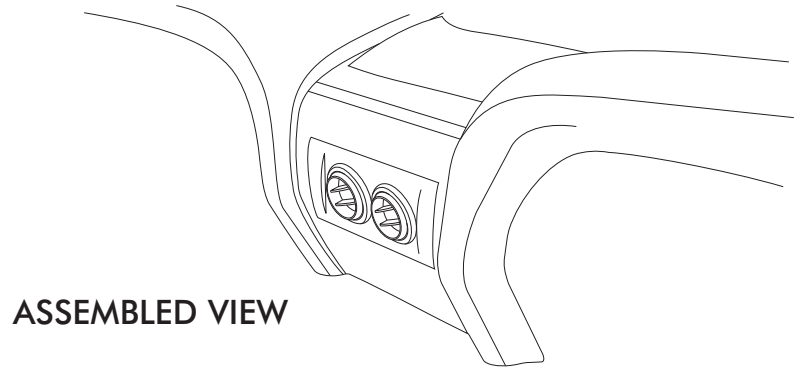
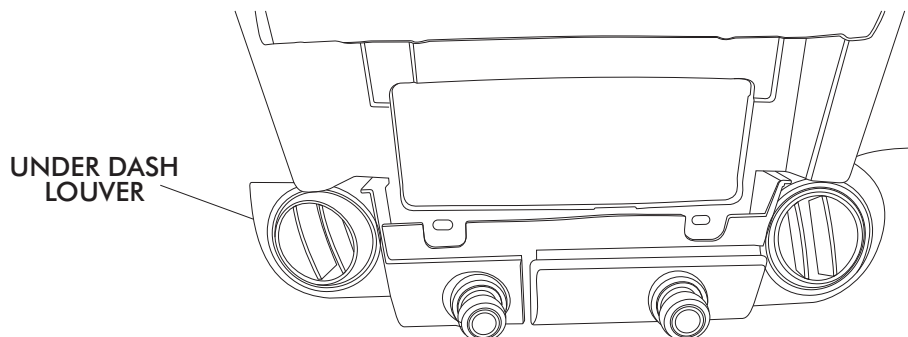

FIGURE 8



### UNDER DASH CENTER LOUVER INSTALLATION (OPTION 2)

- INSTALL UNDER DASH LOUVERS USING (3) #8 X 1/2 PAN HEAD SCREWS.





### DRAIN HOSE INSTALLATION

- LOCATE EVAPORATOR DRAIN ON BOTTOM OF EVAPORATOR CASE.
- IN-LINE WITH THE DRAIN, LIGHTLY MAKE A MARK ON THE FIREWALL. MEASURE ONE INCH DOWN AND DRILL A 5/8 HOLE THROUGH THE FIREWALL. SEE FIGURE 9
- INSTALL DRAIN HOSE TO BOTTOM OF EVAPORATOR UNIT AND ROUTE THROUGH FIREWALL. SEE FIGURE 9.

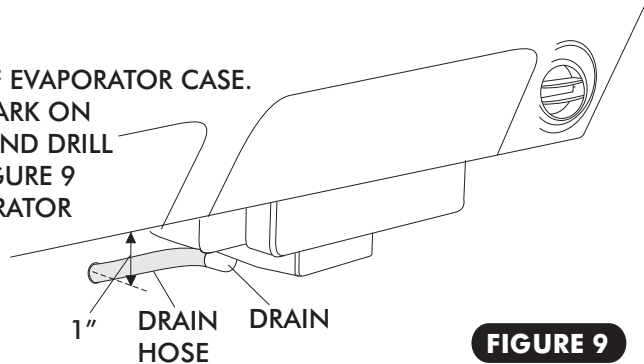

**FIGURE 9**

### LUBRICATING O-RINGS

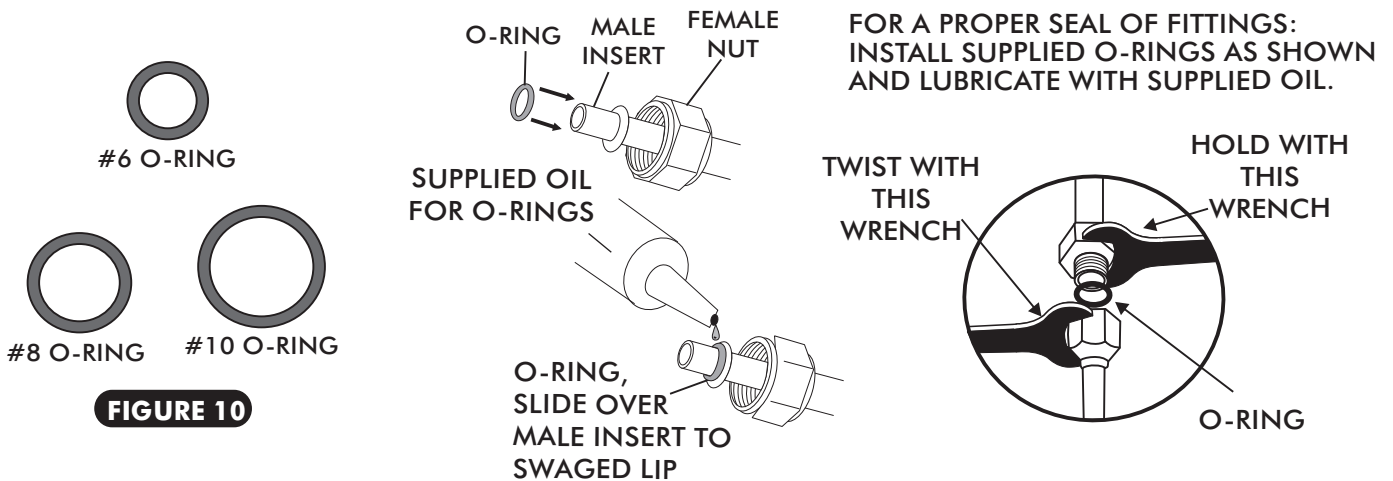

**FIGURE 10**

### STANDARD HOSE KIT

- LOCATE THE #8 COMPRESSOR A/C HOSE. LUBRICATE (2) #8 O-RINGS (SEE FIGURE 10, ABOVE) AND CONNECT THE 45° FITTING TO THE #8 DISCHARGE PORT ON THE COMPRESSOR. ROUTE THE STR FEMALE w/ 134a SERVICE PORT FITTING TO THE #8 CONDENSER HARDLINE COMING THROUGH THE RADIATOR CORE SUPPORT. SEE FIGURE 12, PAGE 13. TIGHTEN EACH FITTING CONNECTION AS SHOWN IN FIGURE 10 ABOVE.
- LOCATE THE #10 COMPRESSOR A/C HOSE. LUBRICATE (2) #10 O-RINGS AND CONNECT THE 90° FEMALE w/ 134a SERVICE PORT FITTING TO THE #10 SUCTION PORT ON THE COMPRESSOR, ROUTE THE 135° FEMALE FITTING TO THE #10 EVAPORATOR HARDLINE COMING THROUGH THE FIREWALL. SEE FIGURES 11, PAGE 12 & FIGURE 12, PAGE 13. TIGHTEN EACH FITTING CONNECTION AS SHOWN IN FIGURE 10 ABOVE.  
**(NOTE: WRAP THE #10 FITTING CONNECTIONS WITH PRESS TAPE. SEE FIGURE 11, PAGE 12 & FIGURE 12, PAGE 13.)**
- LOCATE THE #6 EVAP/DRIER A/C HOSE. LUBRICATE (2) #6 O-RINGS AND CONNECT THE STR FEMALE FITTING TO THE #6 DRIER HARDLINE COMING THROUGH THE RADIATOR CORE SUPPORT. ROUTE THE 90° FEMALE FITTING TO THE #6 EVAPORATOR HARDLINE COMING THROUGH THE FIREWALL. SEE FIGURES 11, PAGE 12 & FIGURE 12, PAGE 13. TIGHTEN EACH FITTING CONNECTION AS SHOWN IN FIGURE 10 ABOVE.
- USE (6) TIE WRAPS TO SECURE THE #6 A/C HOSE TO THE EXPORT BRACE AS SHOWN IN FIGURE 12, PAGE 13.

### MODIFIED A/C HOSE KIT

- REFER TO SEPARATE INSTRUCTIONS INCLUDED WITH MODIFIED HOSE KIT.



## HEATER HOSE & HEATER CONTROL VALVE INSTALLATION

- ROUTE A PIECE OF HEATER HOSE FROM THE WATER PUMP TO THE HEATER LINE COMING THROUGH THE FIREWALL AS SHOWN IN FIGURE 11, BELOW. SECURE USING HOSE CLAMPS.
- ROUTE A PIECE OF HEATER HOSE FROM THE INTAKE TO THE HEATER LINE COMING THROUGH THE FIREWALL AS SHOWN IN FIGURE 11 BELOW. NOTE: INSTALL HEATER CONTROL VALVE IN-LINE WITH INTAKE MANIFOLD (PRESSURE SIDE) HEATER HOSE, SECURE USING HOSE CLAMPS AS SHOWN IN FIGURE 11 BELOW. **NOTE PROPER FLOW DIRECTION.**

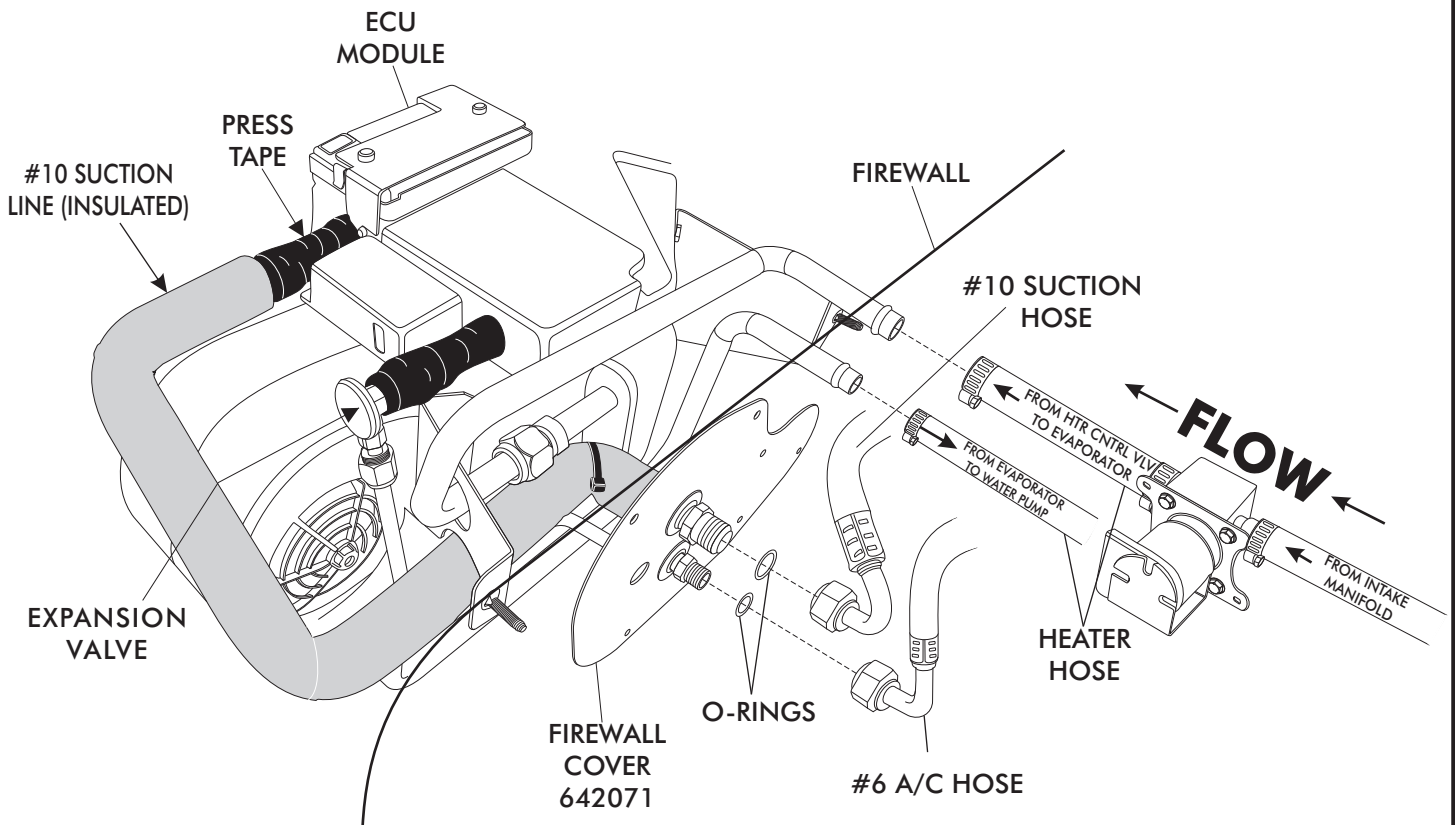
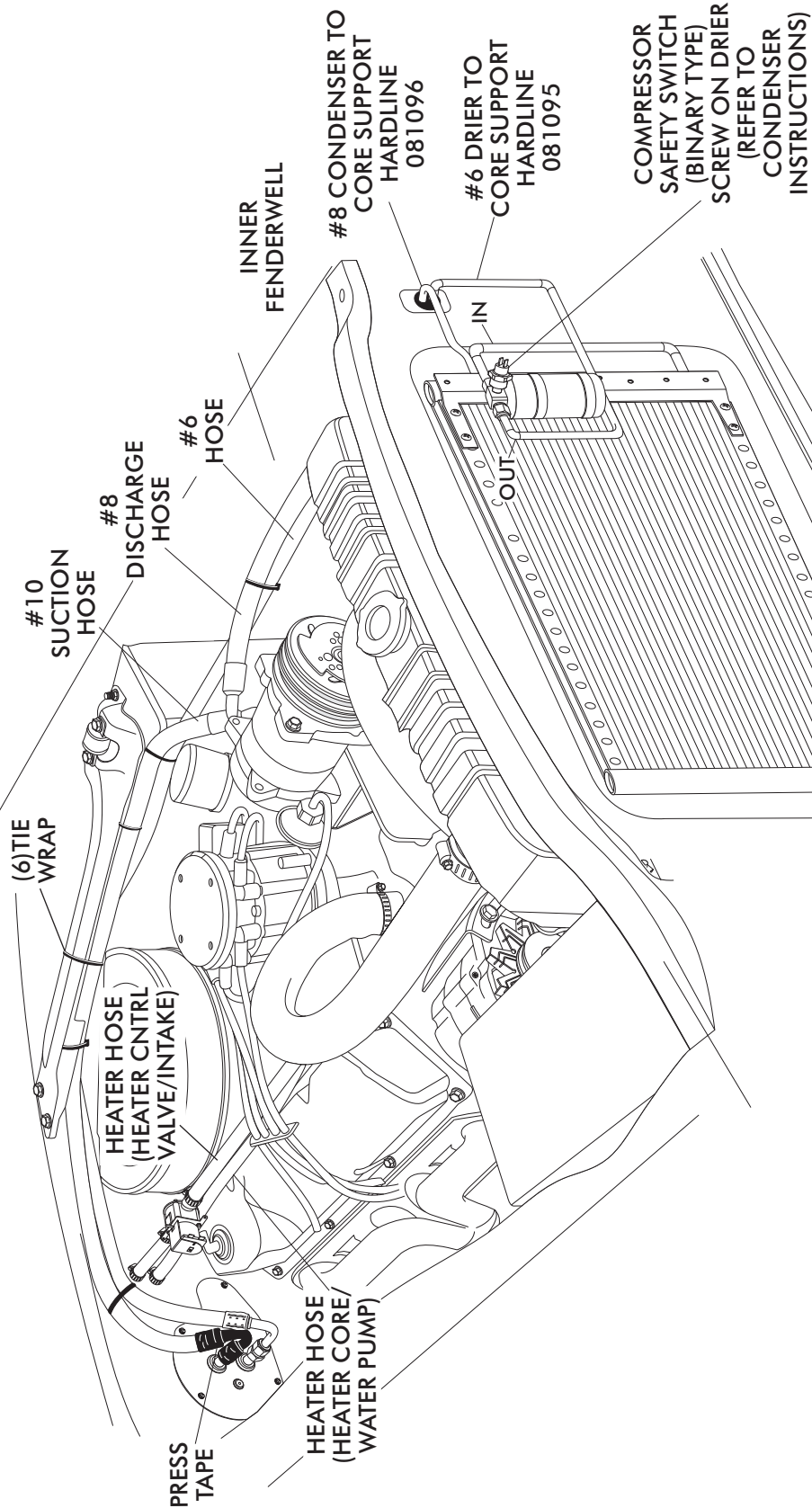

**FIGURE 11**



# AC & HEATER HOSE ROUTING

**NOTE:** VINTAGE AIR SYSTEMS REQUIRE (2) 5/8 HOSE NIPPLES (NOT SUPPLIED)



**FIGURE 12**



## FINAL STEPS

- INSTALL DUCT HOSES AS SHOWN IN FIGURE 14, PAGE 15.
- ROUTE A/C WIRES THROUGH 3/8 GROMMET AS SHOWN ON FIGURE 13a (12 VOLT/ GROUND/ BINARY SWITCH/ HEATER VALVE).
- INSTALL CONTROL PANEL ASM.
- PLUG THE WIRING HARNESS IN THE ECU MODULE ON SUB CASE AS SHOWN IN FIGURE 14, PAGE 15 (WIRE ACCORDING TO WIRING DIAGRAM ON PAGE 17 AND 18)
- GLOVE BOX INSTALLATION (SEE FIGURE 13)
- REINSTALL ALL PREVIOUSLY REMOVED ITEMS (BATTERY).
- FILL RADIATOR WITH AT LEAST A 50/50 MIXTURE OF APPROVED ANTIFREEZE AND DISTILLED WATER. IT IS THE OWNER'S RESPONSIBILITY TO KEEP THE FREEZE PROTECTION AT THE PROPER LEVEL FOR THE CLIMATE IN WHICH THE VEHICLE IS OPERATED. FAILURE TO FOLLOW ANTIFREEZE RECOMMENDATIONS WILL CAUSE HEATER CORE TO CORRODE PREMATURELY AND POSSIBLY BURST IN AC MODE AND/OR FREEZING WEATHER, VOIDING YOUR WARRANTY.
- DOUBLE CHECK ALL FITTINGS, BRACKETS AND BELTS FOR TIGHTNESS.
- VINTAGE AIR RECOMMENDS THAT ALL AC SYSTEMS BE SERVICED BY A CERTIFIED AUTOMOTIVE AIR CONDITIONING TECHNICIAN.
- EVACUATE THE SYSTEM FOR A MINIMUM OF 45 MINUTES PRIOR TO CHARGING AND LEAK CHECK PRIOR TO SERVICING.
- CHARGE THE SYSTEM TO THE CAPACITIES STATED ON THE INFORMATION PAGE (PAGE 4) OF THIS INSTRUCTION MANUAL.
- SEE OPERATION OF CONTROLS PROCEDURES PAGE 19.

## GLOVE BOX INSTALLATION

- INSTALL GLOVE BOX WITH OEM SCREWS. SEE FIGURE 13.

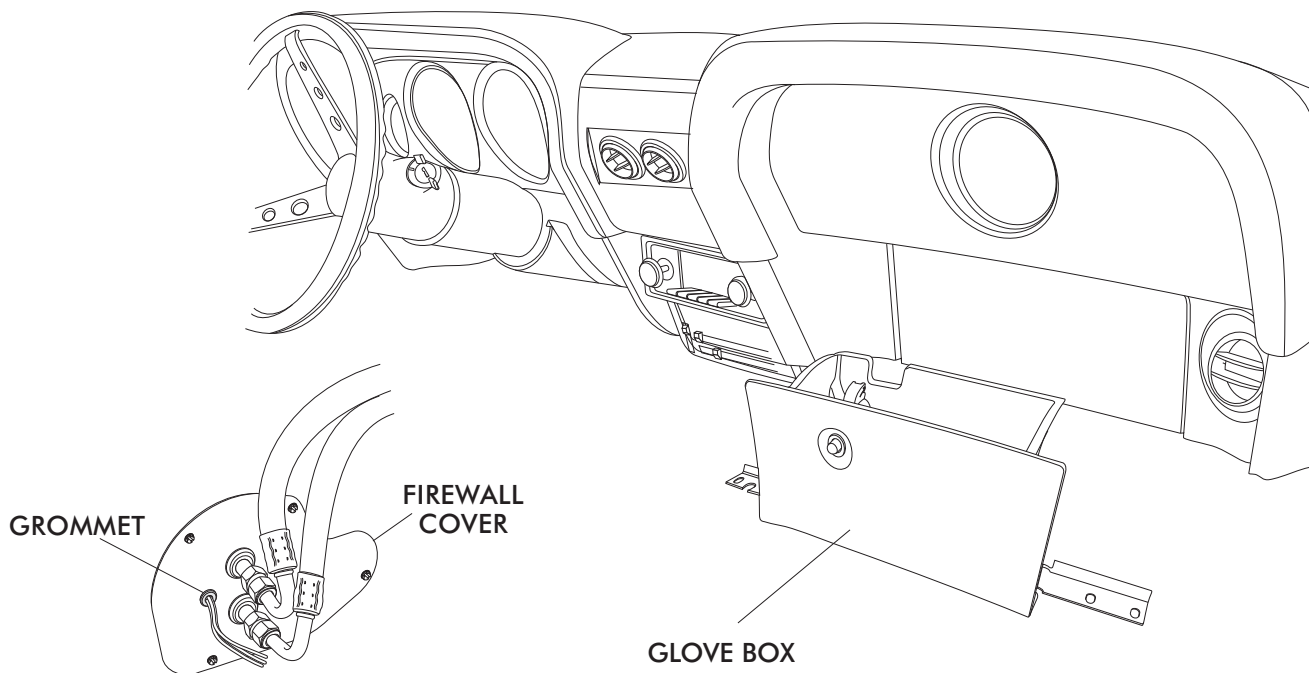

**FIGURE 13a**

**FIGURE 13**



DUCT HOSE ROUTING

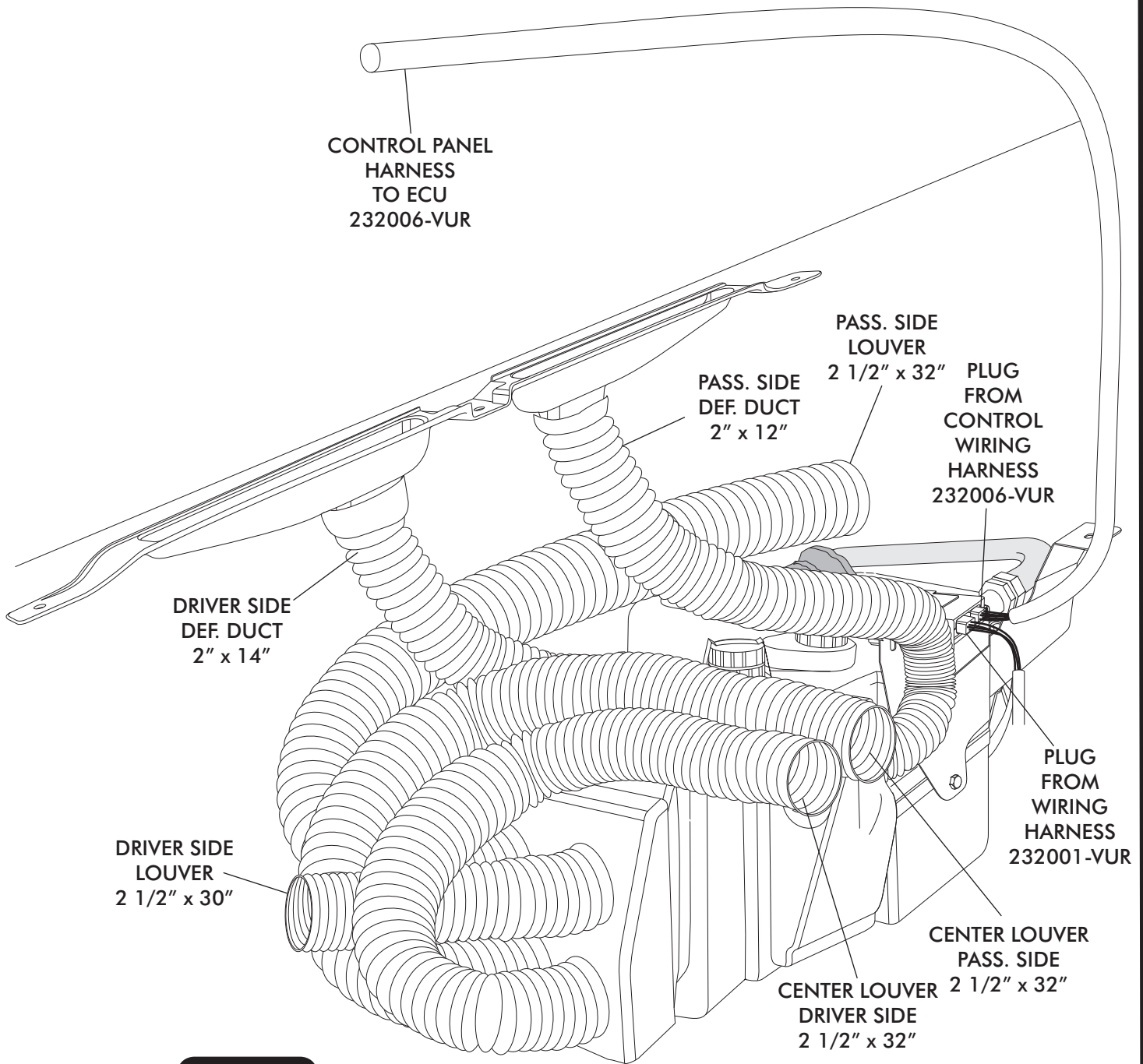
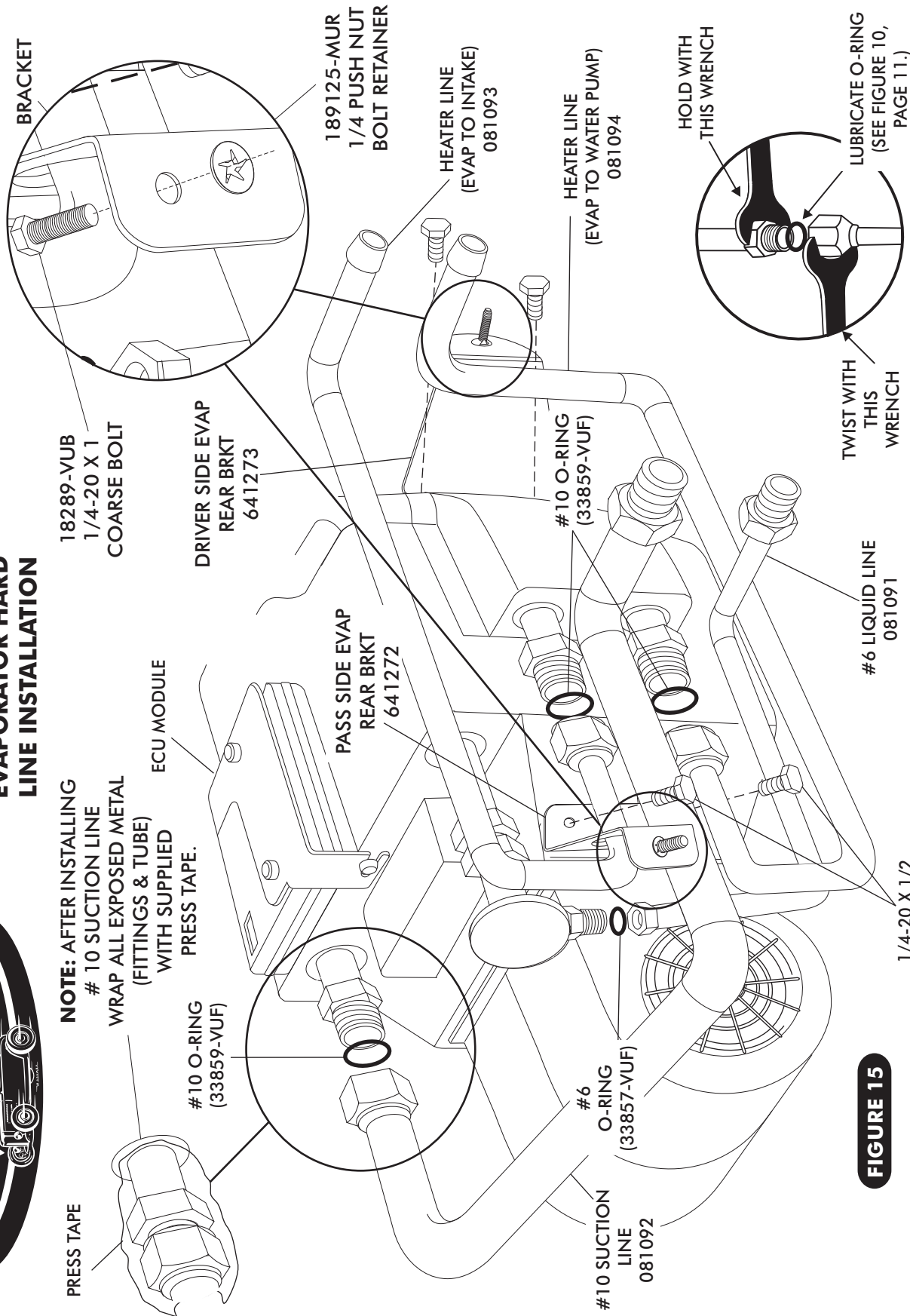

FIGURE 14



**EVAPORATOR HARD LINE INSTALLATION**

**NOTE:** AFTER INSTALLING # 10 SUCTION LINE WRAP ALL EXPOSED METAL (FITTINGS & TUBE) WITH SUPPLIED PRESS TAPE.

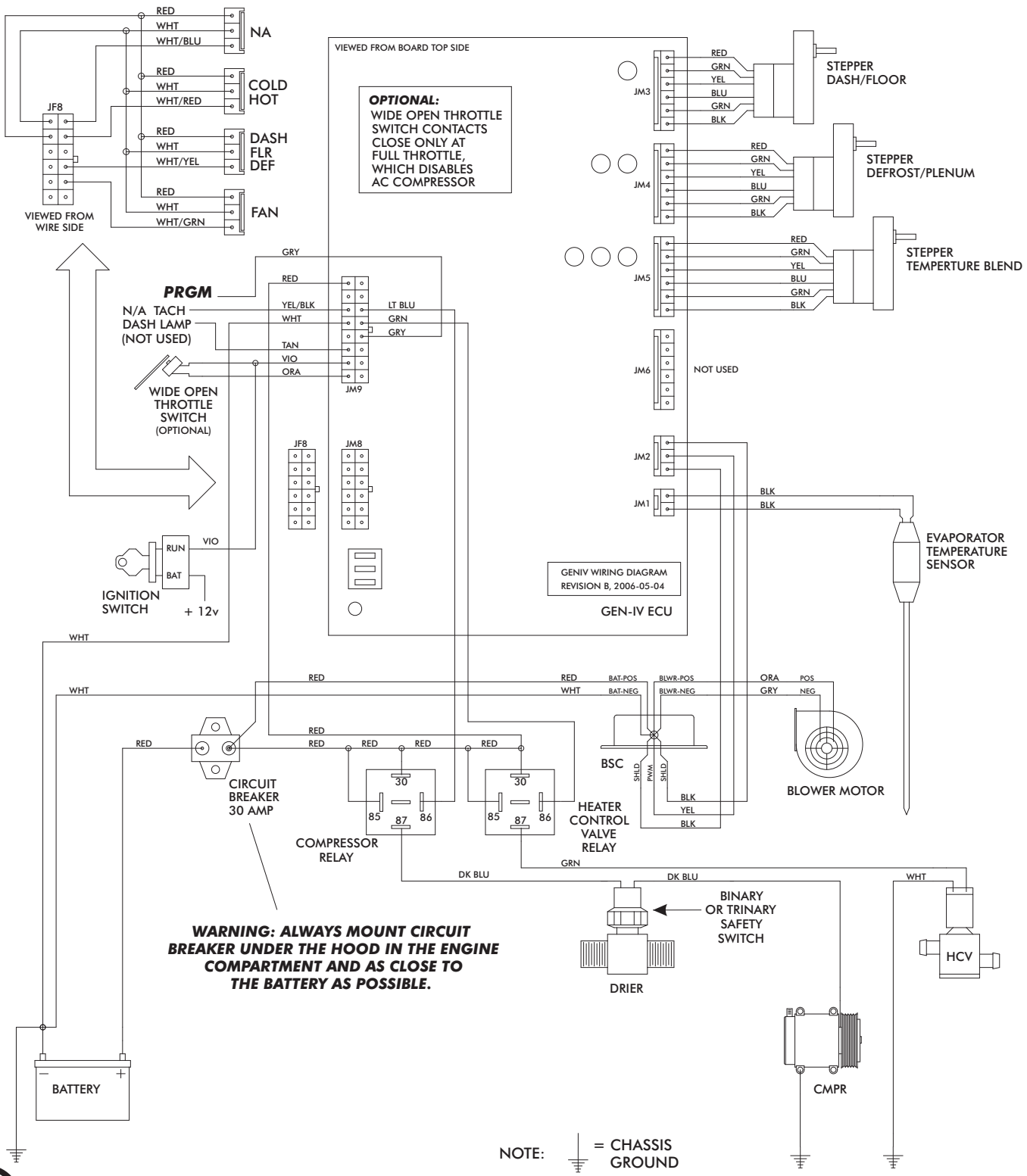

**FIGURE 15**





# WIRING DIAGRAM





# GEN IV WIRING CONNECTION INSTRUCTIONS

REFER TO CONTROL PANEL INSTRUCTIONS AND PLUG IN ACCORDINGLY

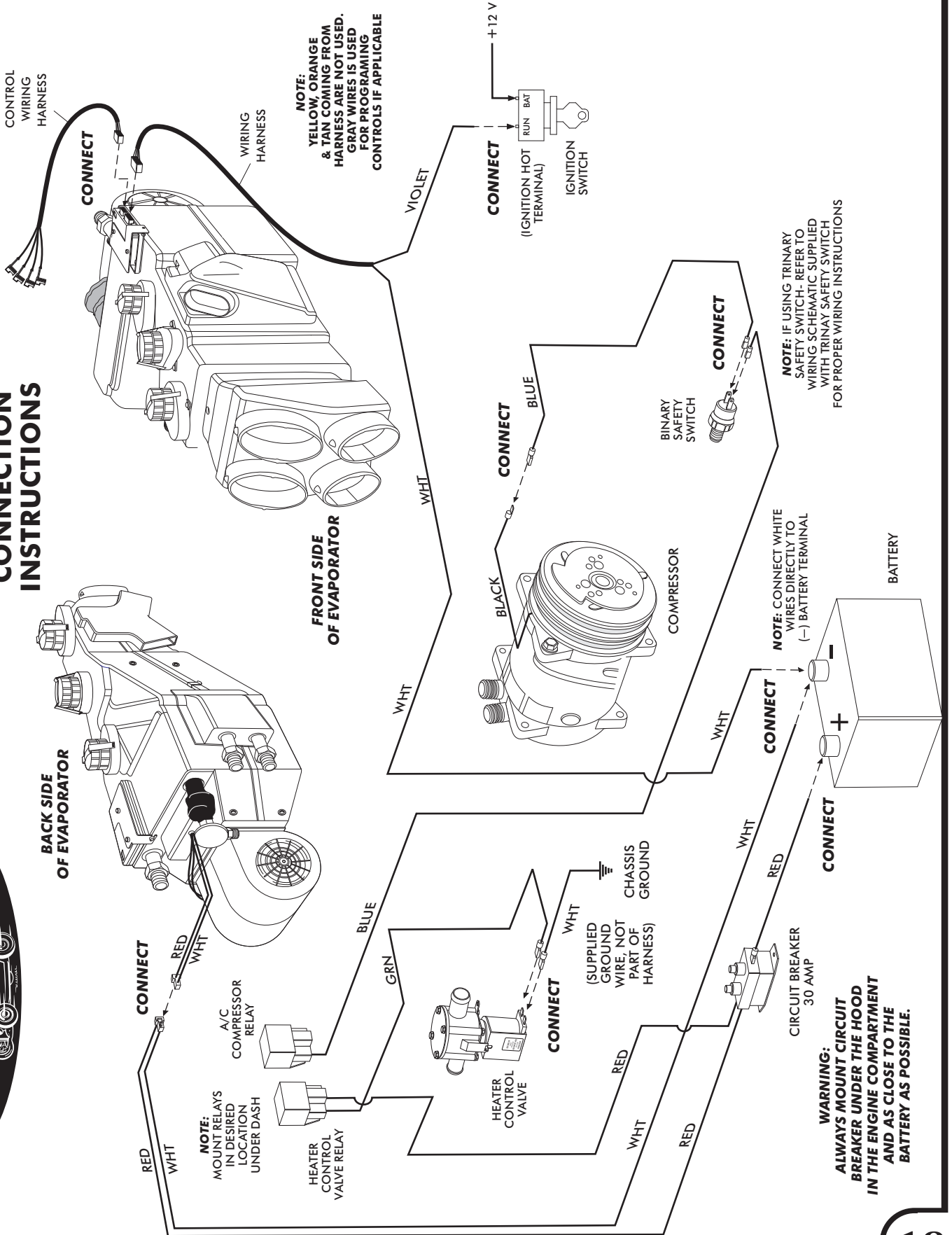

**WARNING:**  
ALWAYS MOUNT CIRCUIT BREAKER UNDER THE HOOD IN THE ENGINE COMPARTMENT AND AS CLOSE TO THE BATTERY AS POSSIBLE.



## OPERATION OF CONTROLS

**NOTE: WHEN BATTERY POWER IS FIRST CONNECTED TO THE ECU, THE COMPUTER GOES THROUGH AN INITIALIZATION SEQUENCE. THIS INITIALIZATION MAY TAKE UP TO 30 SECONDS. DURING INITIALIZATION THE BLOWER WILL NOT OPERATE, BUT THE DOORS INSIDE THE UNIT WILL BE OPERATING. A LOW BATTERY OR DISCONNECTING THE BATTERY MAY ALSO TRIGGER A RE-INITIALIZATION. DURING START UP, A LOW BATTERY MAY DROP BELOW 7 VOLTS, TRIGGERING RE-INITIALIZATION.**

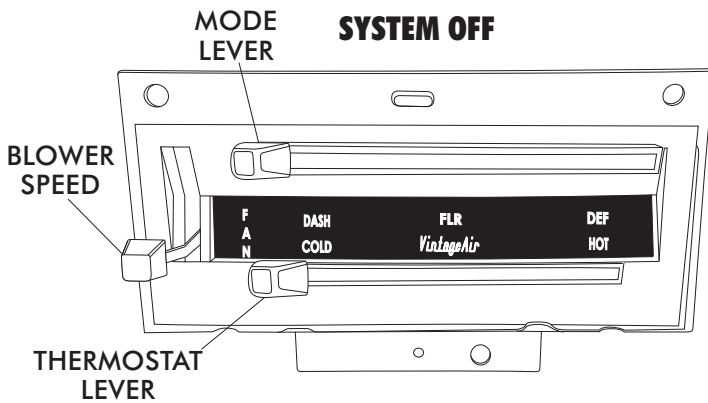

**BLOWER SPEED**  
THIS LEVER CONTROLS THE BLOWER SPEED, FROM OFF TO HI

**MODE LEVER**  
SLIDE THE LEVER TO THE "DASH" POSITION

**THERMOSTAT LEVER**  
IN A/C MODE SLIDE THE THERMOSTAT LEVER ALL THE WAY LEFT TO THE COLD POSITION, FOR MAXIMUM COOLING (SLIDE LEVER LEFT OR RIGHT TO ADJUST DESIRED TEMPERATURE)

### A/C MODE

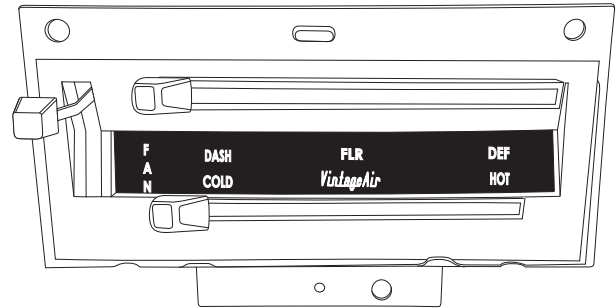

**BLOWER SPEED**  
SLIDE LEVER UP TO DESIRED BLOWER SPEED, FROM OFF TO HI

**MODE LEVER**  
SLIDE THE LEVER TO THE "DASH" POSITION

**THERMOSTAT LEVER**  
IN A/C MODE SLIDE THE THERMOSTAT LEVER ALL THE WAY LEFT TO THE COLD POSITION TO ENGAGE COMPRESSOR, FOR MAXIMUM COOLING (SLIDE LEVER LEFT OR RIGHT TO ADJUST DESIRED TEMPERATURE)

### HEAT MODE

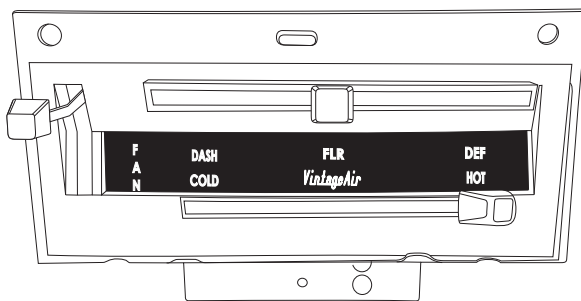

**BLOWER SPEED**  
SLIDE LEVER UP TO DESIRED BLOWER SPEED, FROM OFF TO HI

**MODE LEVER**  
SLIDE THE LEVER TO THE "FLR" POSITION

**THERMOSTAT LEVER**  
IN HEAT MODE SLIDE THE THERMOSTAT LEVER ALL THE WAY RIGHT TO THE HOT POSITION, FOR MAXIMUM HEATING ((SLIDE LEVER LEFT OR RIGHT TO ADJUST DESIRED TEMPERATURE)

### DEFROST/ DE-FOG MODE

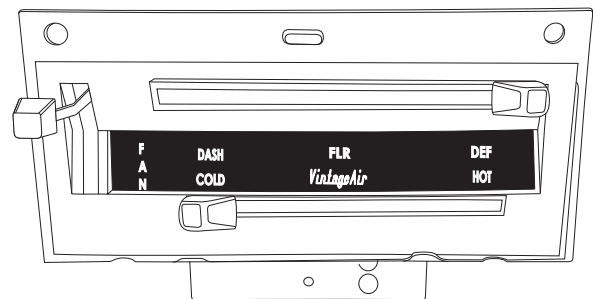

**BLOWER SPEED**  
SLIDE LEVER UP TO DESIRED BLOWER SPEED, FROM OFF TO HI

**MODE LEVER**  
SLIDE THE LEVER TO THE "DEF" POSITION

**THERMOSTAT LEVER**  
IN DEF MODE SLIDE THE THERMOSTAT LEVER ALL THE WAY LEFT TO THE COLD POSITION TO ENGAGE COMPRESSOR. FOR MAXIMUM COOLING (SLIDE LEVER LEFT OR RIGHT TO ADJUST DESIRED TEMPERATURE)



## TROUBLE SHOOTING INFORMATION

SYMPTOM	CONDITION	CHECKS	ACTIONS	NOTES
1. BLOWER STAYS ON HIGH SPEED WHEN IGNITION IS ON	NO OTHER FUNCTIONS WORK	CHECK FOR DAMAGED PINS OR WIRES IN CONTROL HEAD PLUG.	VERIFY ALL PINS ARE INSERTED INTO PLUG. INSURE NO PINS ARE BENT OR DAMAGED IN ECU.	
		CHECK FOR DAMAGED GROUND WIRE (WHITE) IN CONTROL HEAD HARNESS.	VERIFY CONTINUITY TO CHASSIS GROUND WITH WHITE CONTROL HEAD WIRE AT VARIOUS POINTS.	LOSS OF GROUND ON THIS WIRE WILL RENDER CONTROL HEAD INOPERABLE
	ALL OTHER FUNCTIONS WORK	CHECK FOR DAMAGED BLOWER SWITCH OR POT AND ASSOCIATED WIRING.		SEE BLOWER SWITCH CHECK PROCEDURE (CONTACT VINTAGE AIR TECH SUPPORT)
BLOWER STAYS ON HIGH SPEED WHEN IGNITION IS ON OR OFF.		UN-PLUG 3 WIRE BSC CONTROL CONNECTOR FROM ECU. IF BLOWER SHUTS OFF, ECU IS EITHER IMPROPERLY WIRED, OR DAMAGED.	BE SURE SMALL, 20GA, WHITE GROUND WIRE IS CONNECTED TO THE BATTERY GROUND POST. IF IT IS, REPLACE ECU.	
		UN-PLUG 3 WIRE BSC CONTROL CONNECTOR FROM ECU. IF BLOWER STAYS RUNNING, THE BSC IS EITHER IMPROPERLY WIRED, OR DAMAGED.	CHECK TO INSURE THAT NO BSC WIRING IS DAMAGED OR SHORTED TO VEHICLE GROUND. THE BSC OPERATES THE BLOWER BY GROUND SIDE PWM SWITCHING. THE POSITIVE WIRE TO THE BLOWER WILL ALWAYS BE HOT. IF THE "GROUND" SIDE OF THE BLOWER IS SHORTED TO CHASSIS GROUND, THE BLOWER WILL RUN ON HI.	
			REPLACE BSC. (THIS WILL REQUIRE EVAPORATOR TO BE REMOVED FROM VEHICLE.)	NO OTHER PART REPLACEMENTS SHOULD BE NECESSARY.

2. COMPRESSOR WILL NOT TURN ON (ALL OTHER FUNCTIONS WORK)	SYSTEM IS NOT CHARGED	SYSTEM MUST BE CHARGED FOR COMP. TO ENGAGE.	CHARGE SYSTEM OR BYPASS PRESSURE SWITCH .	<b>DANGER- NEVER BYPASS SAFETY SWITCH WITH ENGINE RUNNING, SERIOUS INJURY CAN RESULT</b>
	SYSTEM IS CHARGED	CHECK FOR FAULTY A/C POT OR ASSOC. WIRING	CHECK CONTINUITY TO GROUND ON WHITE CONTROL HEAD WIRE. CHECK FOR 5V ON RED CONTROL HEAD WIRE.	TO CHECK FOR PROPER POT FUNCTION, CHECK VOLTAGE AT WHITE/BLUE WIRE. VOLTAGE SHOULD BE BETWEEN 0 AND 5V, AND WILL VARY WITH POT LEVER POSITION.
		CHECK FOR DISCONNECTED OR FAULTY THERMISTOR.	CHECK TWO PIN CONNECTOR AT ECU HOUSING.	DISCONNECTED OR FAULTY THERMISTOR WILL CAUSE COMPRESSOR TO BE DISABLED.
		(CHECK FOR FAULTY PRESSURE SWITCH)	CHECK CONTINUITY ACROSS SWITCH	REPLACE SWITCH
3. COMPRESSOR WILL NOT TURN OFF (ALL OTHER FUNCTIONS WORK)		CHECK FOR FAULTY A/C POT OR ASSOC. WIRING	REPAIR/REPLACE POT/CONTROL WIRING	RED WIRE @ A/C POT SHOULD HAVE APPROX. 5V WITH IGNITION ON. WHITE WIRE WILL HAVE CONTINUITY TO CHASSIS GROUND. WHITE/BLUE WIRE SHOULD VARY BETWEEN 0V AND 5V WHEN LEVER IS MOVED UP AND DOWN.
		CHECK FOR FAULTY A/C RELAY FOR '55-56 CHEV. CHECK FOR PROPER PANEL CONVERSION. CONTROL LEVERS SHOULD TRAVEL TO WITHIN 1/8" OF BOTH ENDS OF THE SLOTS.	REPLACE RELAY REFER TO INSTRUCTIONS "55-56 CONTROL PANEL CONVERSION REV B 6.17.05" PDF OR 903055-PCA REV C 8/10/05 OR LATER INSTRUCTION MANUAL.	EARLY INSTRUCTIONS ON '55-56 CHEV. DID NOT INCLUDE PANEL MOD PROCEDURE FOR CONTROL WITH LOWER POT BRACKET OFFSET BACK FROM CASTING. IF LEVERS ONLY TRAVEL 2/3 TO 3/4 UP, THIS PROCEDURE MUST BE PERFORMED
			REPLACE ECU.	



# TROUBLE SHOOTING INFORMATION CONT.

4. SYSTEM WILL NOT TURN ON OR RUNS INTERMITTENTLY	WORKS WHEN ENGINE IS NOT RUNNING, SHUTS OFF WHEN ENGINE IS STARTED. (TYPICALLY EARLY GEN 4, BUT POSSIBLE ON ALL VERSIONS)	NOISE INTERFERENCE FROM EITHER IGNITION OR ALTERNATOR.	INSTALL CAPACITORS ON IGN. COIL, AND ALTERNATOR. ENSURE GOOD GROUND AT ALL POINTS. RE-LOCATE COIL AND ASSOCIATED WIRING AWAY FROM ECU AND ECU WIRING. CHECK FOR BURNED OR LOOSE PLUG WIRES.	IGNITION NOISE (RADIATED OR CONDUCTED) WILL CAUSE THE SYSTEM TO SHUT DOWN DUE TO HIGH VOLTAGE SPIKES. IF THIS IS SUSPECTED, CHECK WITH A QUALITY OSCILSCOPE. SPIKES GREATER THAN 16V WILL SHUT DOWN ECU. INSTALL A RADIO CAPACITOR AT THE POSITIVE POST OF THE IGNITION COIL (SEE RADIO CAPACITOR INSTALLATION BULLETIN). A FAULTY ALTERNATOR OR WORN OUT BATTERY CAN ALSO RESULT IN THIS CONDITION. BATTERY MUST BE IN GOOD CONDITION FOR ALTERNATOR REGULATOR TO FUNCTION PROPERLY.
5. LOSS OF MODE DOOR FUNCTION	WILL NOT TURN ON UNDER ANY CONDITIONS	VERIFY CONNECTIONS ON POWER LEAD, IGNITION LEAD, AND BOTH WHITE GROUND WIRES. VERIFY BATTERY VOLTAGE IS GREATER THAN 10 VOLTS AND LESS THAN 16.	CHECK FOR POSITIVE POWER AT HEATER VALVE GREEN WIRE, AND BLOWER RED WIRE. CHECK FOR GROUND ON CONTROL HEAD WHITE WIRE. VERIFY PROPER METER FUNCTION BY CHECKING A KNOWN GOOD BATTERY'S VOLTAGE.	
6. BLOWER TURNS ON AND OFF RAPIDLY	NO MODE CHANGE AT ALL PARTIAL FUNCTION OF MODE DOORS	CHECK FOR DAMAGED MODE SWITCH OR POT AND ASSOCIATED WIRING CHECK FOR OBSTRUCTED OR BINDING MODE DOORS CHECK FOR DAMAGED STEPPER MOTOR OR WIRING	INSURE ALL SYSTEM GROUNDS AND POWER CONNECTIONS ARE CLEAN AND TIGHT. CHARGE BATTERY	TYPICALLY CAUSED BY EVAPORATOR HOUSING INSTALLED IN A BIND IN THE VEHICLE. BE SURE ALL MOUNTING LOCATIONS LINE UP AND DON'T HAVE TO BE FORCED INTO POSITION.
7. ERATIC FUNCTIONS OF BLOWER, MODE, TEMP, ETC.	BATTERY VOLTAGE IS AT LEAST 12V BATTERY VOLTAGE IS LESS THAN 12V	CHECK FOR AT LEAST 12V BETWEEN GREEN HEATER VALVE WIRE AND CHASSIS GROUND. CHECK FOR FAULTY BATTERY OR ALTERNATOR	REPAIR OR REPLACE ASSOCIATED WIRING	SYSTEM SHUTS OFF BLOWER AT 10V. POOR CONNECTIONS OR WEAK BATTERY CAN CAUSE SHUT DOWN AT UP TO 11V
8. WHEN THE IGNITION IS TURNED ON, THE BLOWER MOMENTARILY COMES ON, THEN SHUTS OFF. THIS IS WITH THE BLOWER SWITCH IN THE OFF POSITION.		THIS IS AN INDICATOR THAT THE SYSTEM HAS BEEN RE-SET. BE SURE THE RED POWER WIRE IS ON THE BATTERY POST AND NOT ON A SWITCHED SOURCE. ALSO, IF THE SYSTEM IS PULLED BELOW 7V EVEN FOR A SPLIT SECOND, THE SYSTEM WILL RE-SET.	RUN RED POWER WIRE DIRECTLY TO BATTERY.	
9. BACKLIGHTING ON CONTROL PANEL ALWAYS ON.	VINTAGE AIR SUPPLIED PANELS ONLY.	TAN WIRE IN MAIN HARNESS IS NOT CONNECTED TO 0-12V GAUGE BACK LIGHT WIRE.	CONNECT TO GAUGE BACK LIGHT WIRE (0-12V) WHICH WHICH CONTROLS DIMMING OF PANEL BACK LIGHT	TAN WIRE IS ONLY USED ON SYSTEMS WITH ENTIRE CONTROL PANEL SUPPLIED BY VINTAGE AIR.
10. BACKLIGHTING ON CONTROL PANEL ALWAYS OFF.	VINTAGE AIR SUPPLIED PANELS ONLY.	TAN WIRE IN MAIN HARNESS NOT CONNECTED.	CONNECT TO GAUGE BACK LIGHT WIRE (0-12V) WHICH WHICH CONTROLS DIMMING OF PANEL BACK LIGHT	



### DRIVER SIDE LOUVER TEMPLATE

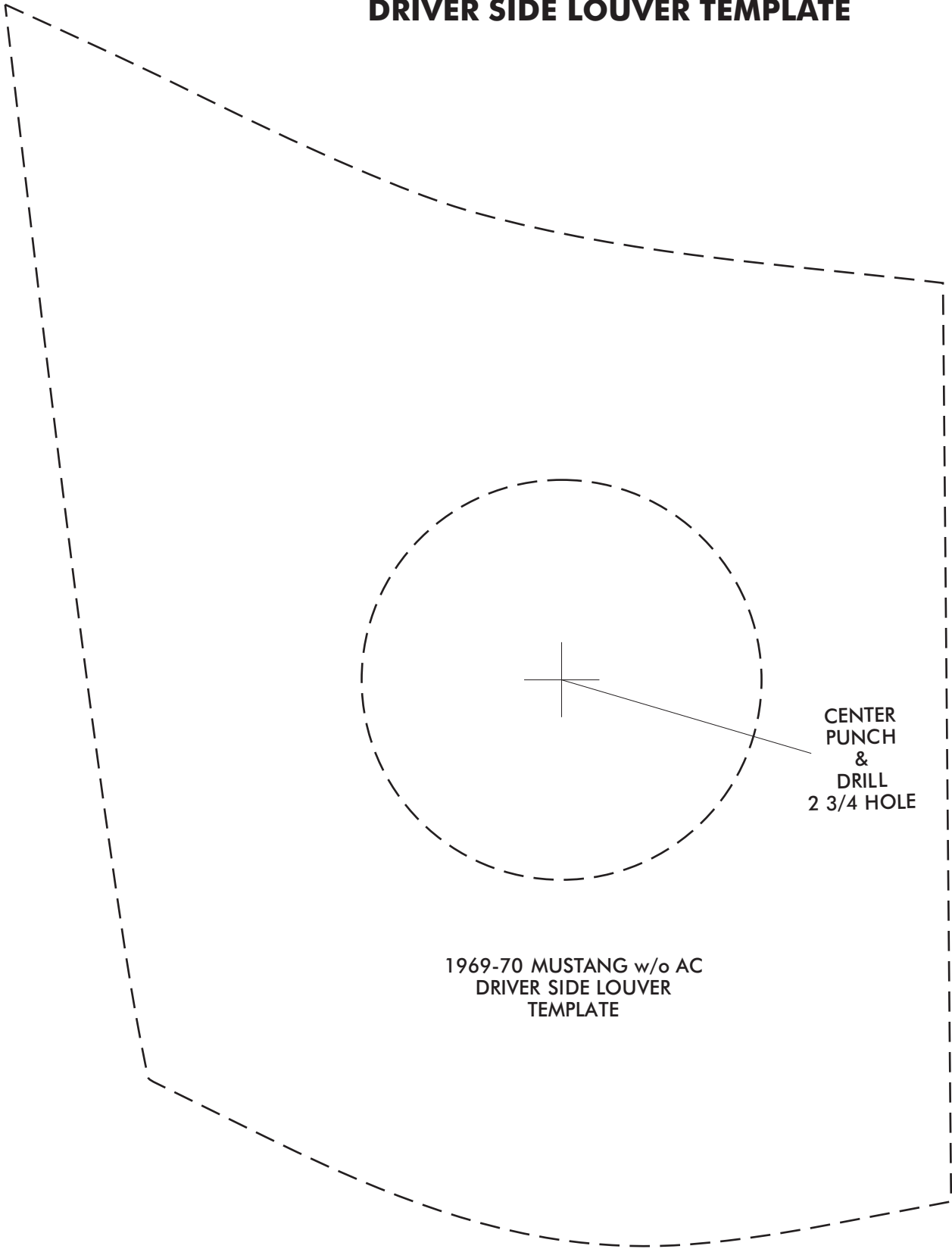

CUT ALONG  
DOTTED LINE



CENTER  
PUNCH  
&  
DRILL  
2 3/4 HOLE

1969-70 MUSTANG w/o AC  
DRIVER SIDE LOUVER  
TEMPLATE

# PASSENGER SIDE LOUVER TEMPLATE

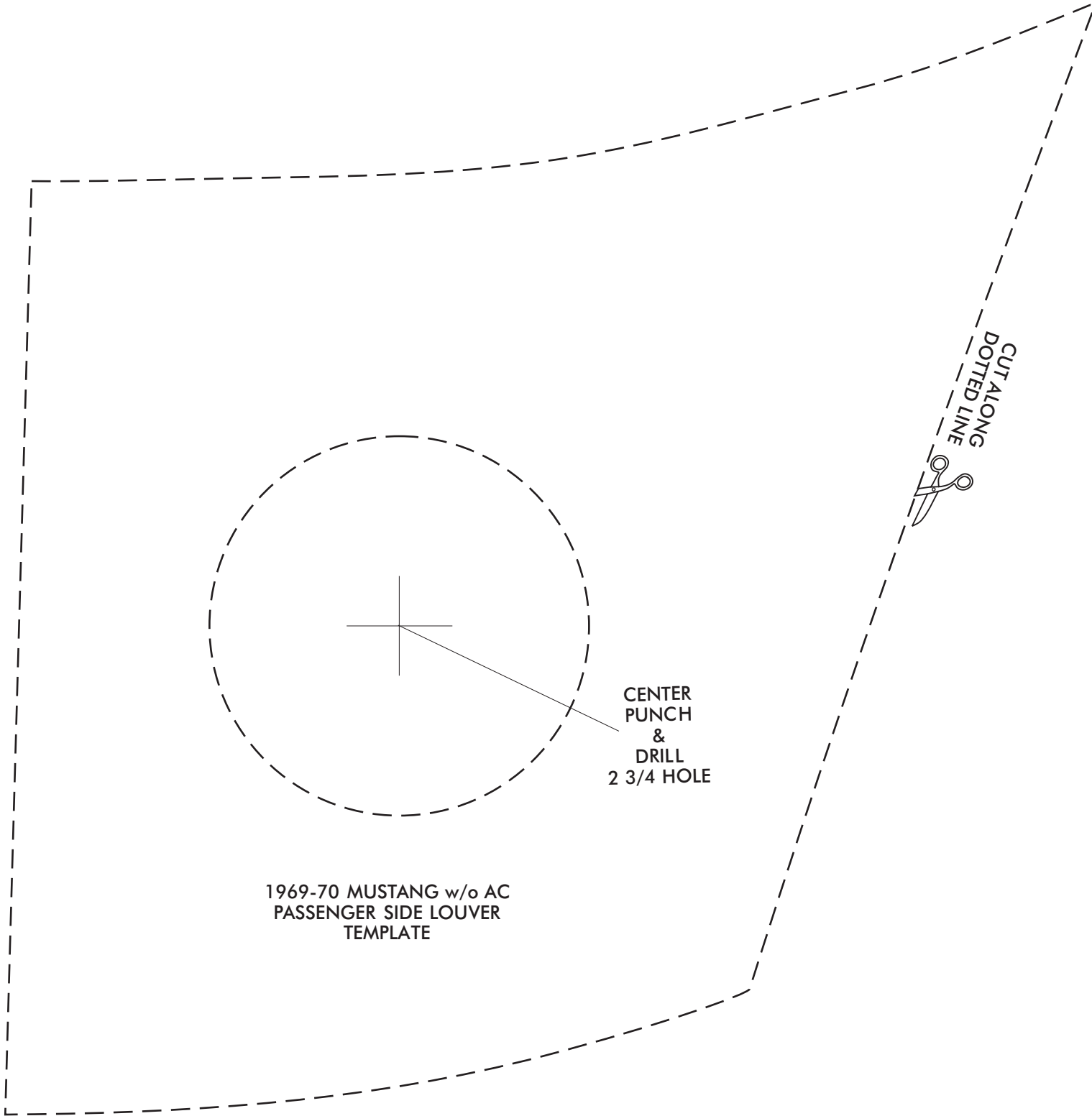



1969-70 MUSTANG w/o AC GEN IV

## CENTER LOUVER TEMPLATE

CUT ALONG  
DOTTED LINE



CUT ALONG  
DOTTED LINE



1969-70 MUSTANG w/o AC  
CENTER LOUVER  
TEMPLATE



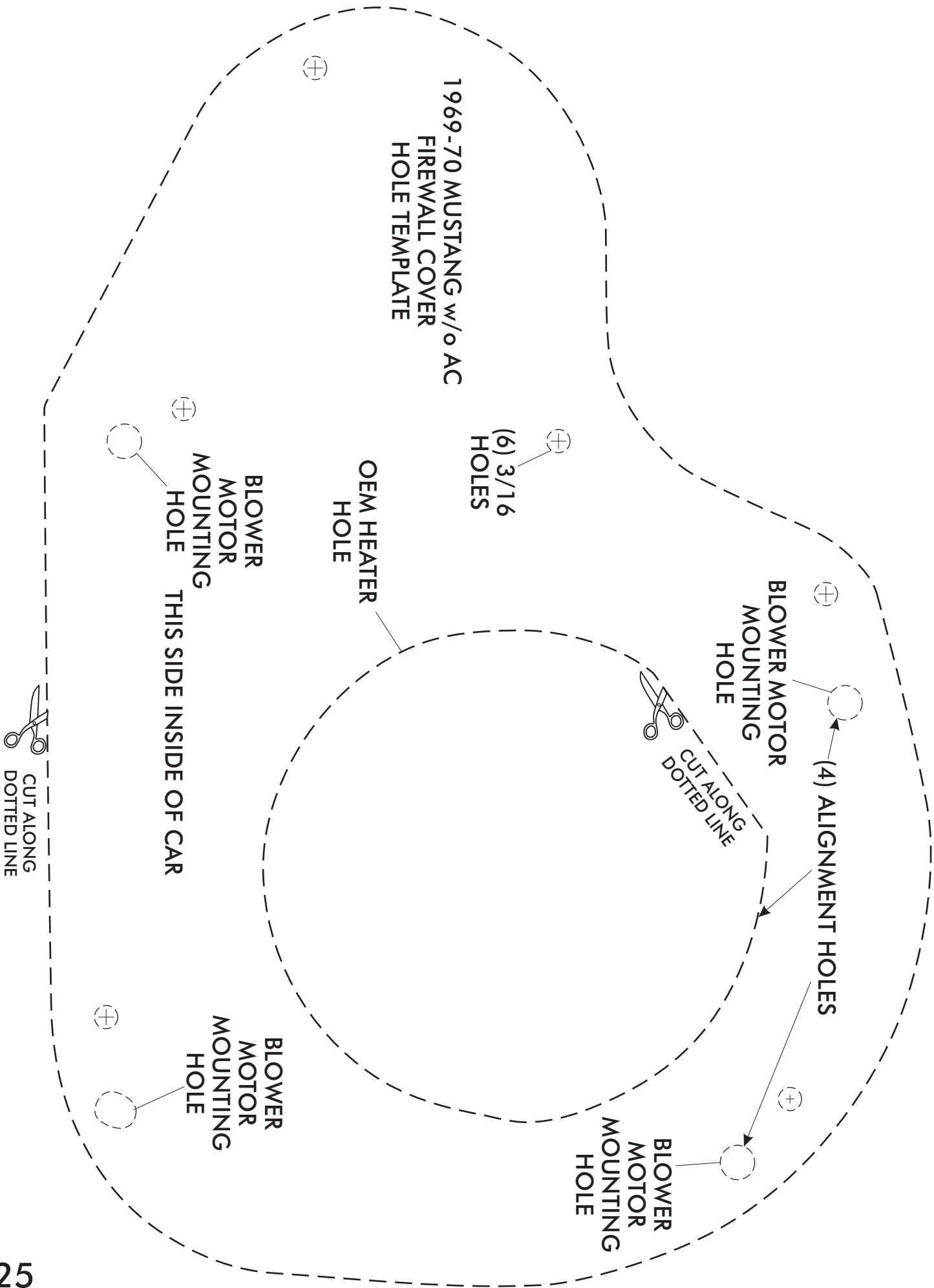



# 1969-70 MUSTANG w/o AC GEN IV

## EVAPORATOR KIT 551170

### EVAPORATOR KIT PACKING LIST

No.	QTY.	PART No.	DESCRIPTION
1.	1	763069	69-70 MUSTANG EVAP. SUB CASE
2.	1	781069	1969-70 MUSTANG w/o AC ACC. KIT

CHECKED BY: \_\_\_\_\_  
 PACKED BY: \_\_\_\_\_  
 DATE: \_\_\_\_\_

①

**69-70 MUSTANG  
EVAP. SUB CASE  
763069**

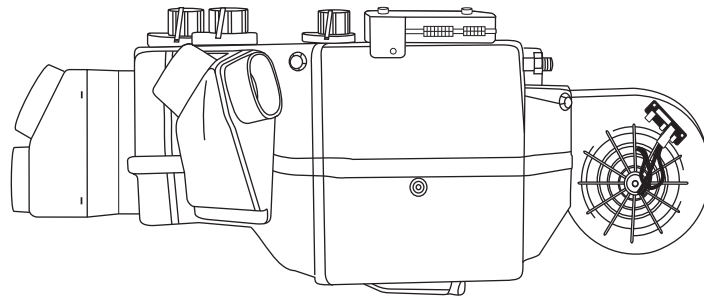

②

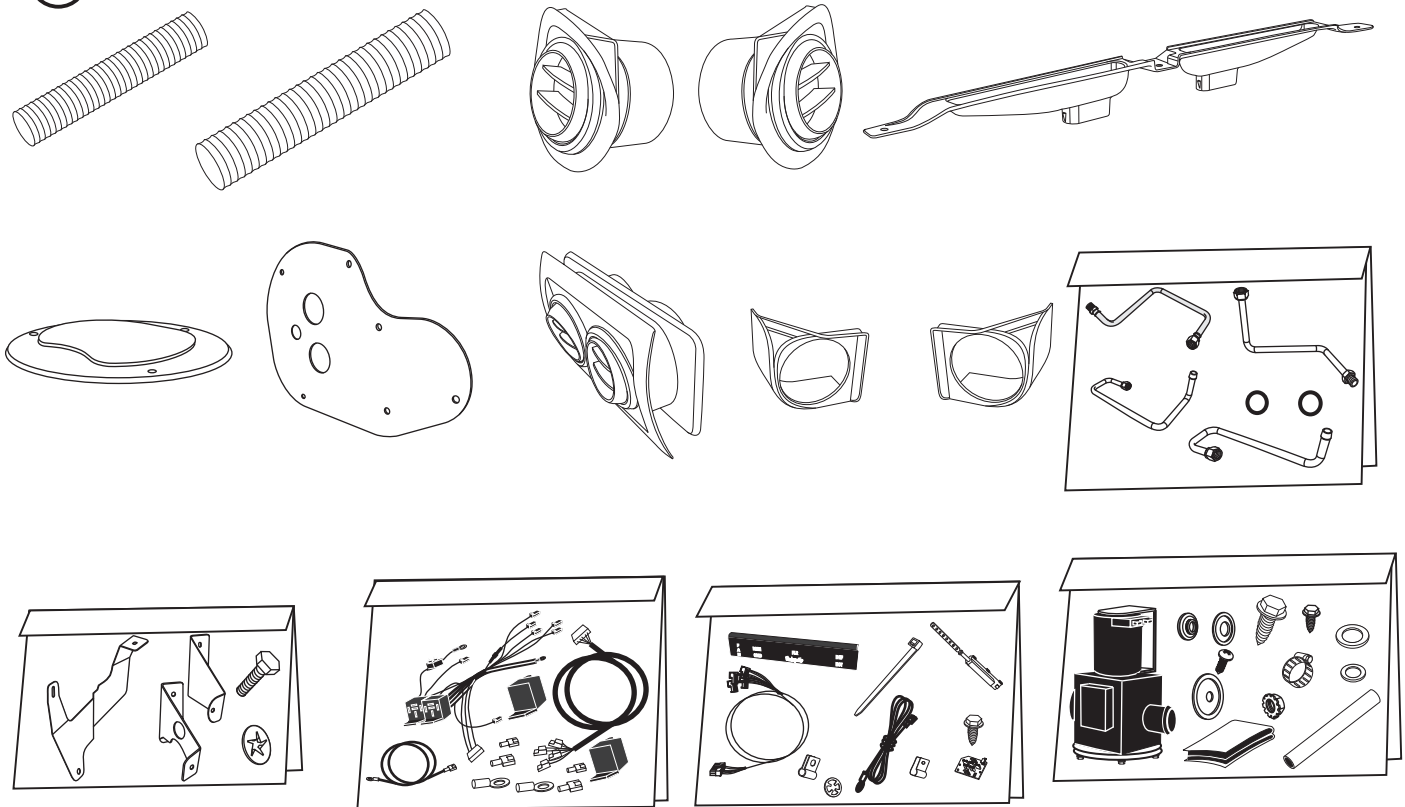

**ACCESSORY KIT  
781069**

**NOTE: IMAGES MAY NOT DEPICT ACTUAL PARTS AND QUANTITIES.  
REFER TO PACKING LIST FOR ACTUAL PARTS AND QUANTITIES**