

Bubble Master

Operator's Manual

Table of Contents

Warning	3
Safety Precautions	3
Technical Specifications	4
Technical Drawings	4
Operating Procedure	5
Shut Down Procedure	5
Troubleshooting	5
Maintenance	6
Recommended Fluid	6
Warranty	7
Contact Information	7

Note: Please read entire manual before operating the Bubble Master



Warning

Important Safety Instructions:

1. Do not remove the outer case.
2. Ensure that this unit is grounded at all times. Failure to do so may result in serious injury.
3. Use Ultratec Special Effects fluid **ONLY**.

Safety Precautions

1. Ensure that any operation of the machine is supervised by suitably trained and authorized personnel.
2. Do not modify the machine or use a machine which has been damaged in any way.
3. Allow sufficient air circulation around the machine at all times.
4. Protect the machine from direct weather effects and wet locations.
5. Only use fluids manufactured by Ultratec Special Effects.
6. Avoid directing bubble output continuously at people, structures or objects within close proximity of the discharge nozzle.
7. Ensure that adequate exhausting arrangements are available in the event of an emergency.

Technical Specifications

Model:	Bubble Master		
Part Number:	CLB 2012 / 120 volt CLB 2015 / 120 volt w/ FDS Option CLB 2014 / 220-240 volt		
Length:	28.4in	72.1cm	*Dimensions include Bubble Projector
Width:	16.3in	41.4cm	
Height:	15.8in	40.1cm	
Net Weight:	21lbs	9.51kg	
Power Rating:	120 Volt A.C. 50/60 Hz. 1 Amps. 240 Volt A.C. 50/60 Hz. 0.5 Amps.		
Fluid:	Water Base Bubble Fluid (Use only Ultratec Fluid)		

Technical Drawings

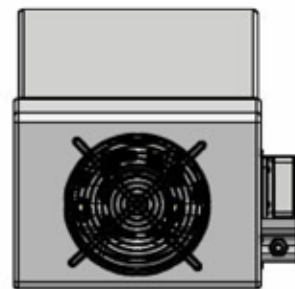
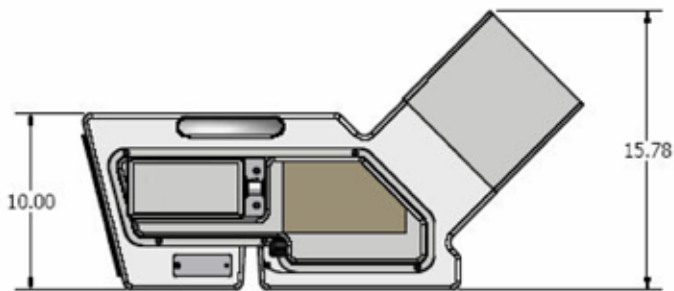
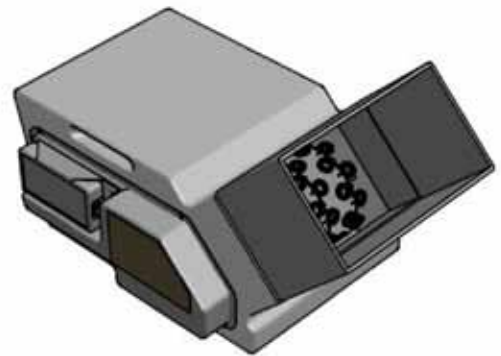
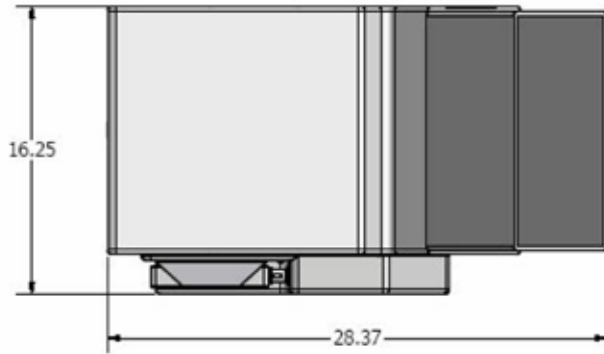

Operating Procedure

Unpack the Bubble Master and inspect all components. Although the packaging was designed for the rigours of today's parcel delivery services, damage may have occurred during shipping.

1. Prior to operation, the extension sleeve may be placed over the bubble outlet. This will allow the bubbles to be projected higher, before they begin to disperse outwards.
2. For lower flying bubbles do not use the extension sleeve.
3. Place the Bubble Master on a level sturdy surface, or use the optional adjustable stand sold separately.
4. Open a container of Ultratec Bubble Fluid, and pierce the foil top. Pour the fluid into the bubble outlet. Fill up to 1/2" below the reservoir top. This initially should take approximately 1 gallon.
5. Plug the Bubble Master into an outlet that is capable of sustaining the current load listed on the product serial plate.
6. Use the Fan Speed Control knob to start the bubble wheel and fans, and to control the fan speed. By varying the fan speed you can control the bubble volume, size and height.

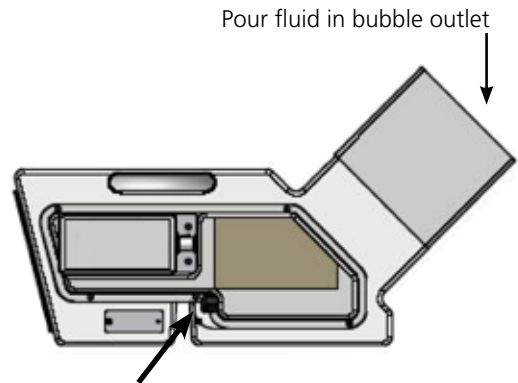
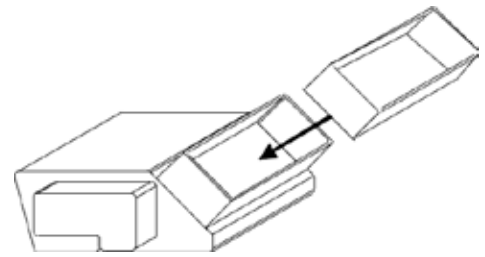

Fill to 0.5in below reservoir top.
Do not overfill past top of reservoir.

Shut Down Procedure

1. Disconnect the Bubble Master from the power source.
2. Remove the bubble extension sleeve if used.
3. Using a funnel, empty the contents of the fluid reservoir back into the 1 gallon fluid container. This can be done by tipping the unit, and pouring the fluid out of the bubble outlet.
4. Replace cap on the fluid container to keep dirt and debris from entering.
5. Rinse out fluid reservoir and bubble wheels with hot tap water to remove excess bubble fluid residue. Using a paper towel wipe out extension sleeve and bubble outlet.
6. Empty into sink or appropriate drain.

Troubleshooting

Bubble Wheel not turning:

Ensure that set screws are secure in bubble wheel motor shaft.

Intermittent bubbles produced:

Ensure that there is enough fluid in the fluid reservoir, and that the bubble wheels are being submersed in bubble fluid.

Maintenance

Fluid Reservoir

When storing the Bubble Master for any extended period, be sure to thoroughly rinse the fluid reservoir.

Bubble Wheel

When storing the Bubble Master for any extended period, be sure to thoroughly rinse bubble wheels.

Recommended Fluid

Bubble Master Bubble Fluid: This Premium Quality Bubble Fluid produces large quantities of bubbles that are drier and longer lasting.

Bubble Fluid Supreme: This Supreme Quality Bubble Fluid produces large quantities of Bubbles that are longer lasting and extremely drier than regular Bubble Fluids. This Bubble Fluid is recommended for applications that require a drier Bubble Effect that doesn't leave a residue.

Warranty

Warranty:	All warranty is for one year parts and labour unless specified or manufacturer defect only. Abuse or Poor Maintenance will not be covered under warranty. Ultratec Special Effects Fluids must always be used. Use of any non Ultratec Special Effects Fluids will void all warranties. Accept no substitutions as there are no exceptions to this rule. Proof of Purchase or Proof of Sale must always accompany any warranty returns. An RA (return authorization) number must be noted on the outside of the box being returned to our facilities. Any packages without a clearly marked RA number will not be accepted by our receiving department. Freight on warranty items are freight prepaid to our facility and we will prepay freight back to your facility after repair by the most economical means available. Should you require the item express-returned, then you are responsible for any difference in freight cost.
Return Policy:	Return of any product must be done within 30 days of purchase. The package must be returned freight prepaid and the RA number clearly marked on the outside of the box. Minimum restocking fee is 25%. Once our facility has received the product a technical assessment will be completed to determine if an additional restocking fee needs to be issued. Only credits are issued to the dealers account. Any product not returned within 30 days is considered purchased.
Warning:	Ultratec Special Effects Inc. considers all of it's product to be safe for use in the application it was intended. Ultratec Special Effects takes no responsibility for misuse or incorrect use. Always refer to the Product Manual for proper use.

Contact Information

Head Office

Ultratec Special Effects Inc.
1960 Blue Heron Drive
London, Ontario N6H 5L9

Direct: 519-659-7972
Toll Free: 866-534-5557
Fax: 519-659-7713

Canadian Shipping Address

(For All Canadian Repairs)
Ultratec Special Effects Inc.
1960 Blue Heron Drive
London, Ontario N6H 5L9

Please remember to include the **RA Number on all items being shipped for repairs.**

To get an RA Number, visit www.ultratecfx.com and click on the "Service" tab and then click on "Master Service Tracker or contact service at 519-951-3357 / 866.534.5557

USA Shipping Address

(For All USA Repairs)
Ultratec Special Effects Inc.
640 Gadson St.
Groveland, Florida 34736