

Oil- and Vacuum-Break Switches

Type S Automatic Load-Transfer Control Installation, Operation, and Maintenance Instructions

S260-75-1

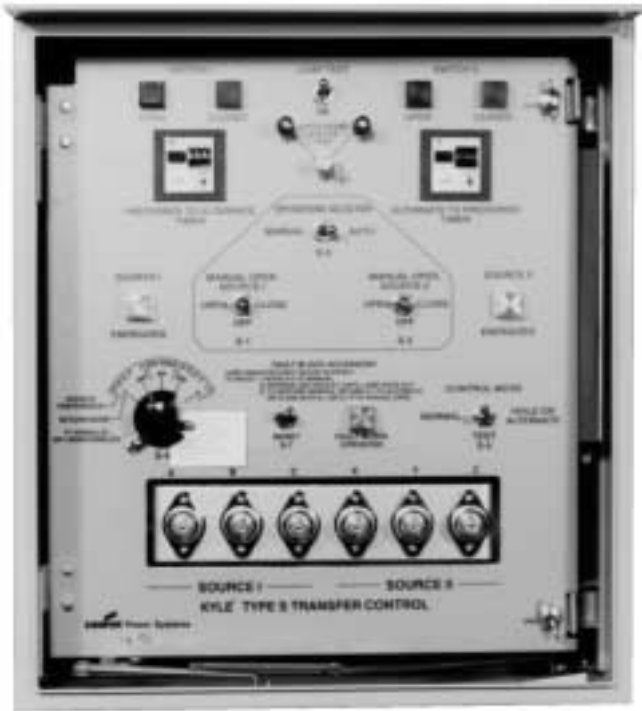

Figure 1.
Kyle® Type S automatic load-transfer control.

020076KM

Contents

Safety Information	2
Hazard Statement Definitions	2
Safety Instructions	2
Product Information	3
Introduction	3
Acceptance and Initial Inspection	3
Handling and Storage	3
ANSI Standards	3
Quality Standards	3
Description of Operation	4
Time Delay Selection	4
Pre-Installation Check	5
Pre-Installation	5
Installation Instructions	6
Initial Programming	6
Mounting the Control	6

Grounding the Control	6
Before Placing the Control and Switchgear in Service	6
Equipment Required	6
Customer Connections	8
Interconnecting Cables	13
Operating Instructions	16
Initial Operation	16
Normal Operation	17
Theory of Operation—Basic S Control	17
Voltage Sensing	17
Automatic Transfer, Preferred to Alternate	18
Return Transfer, Parallel Transition	18
Return Transfer, Non-Parallel Transition	18
No Preference Mode	19
Preferred Source II Mode	19
Control Mode Switch, S5	19
Manual Control	19
Indicating Lamps	19
Remove the Control from Service	20
Troubleshooting—Basic S Control	20
General	20
Basic Troubleshooting	20
Advanced Troubleshooting	21
Fault Block Accessory	28
General Description	28
Accessory Settings	28
Operating Instructions	29
Theory of Operation—Fault Block Accessory	29
Overcurrent Sensing	29
Phase Fault Operation	29
Ground Fault Operation	32
Reset Circuits	32
Inrush Restraint Feature	32
Testing Fault Block Operation	33
Returning the Control to Service	35
Wiring Tables	36
Replacement Parts	40
Front Panel—Replacement Parts List	41
Back Panel—Replacement Parts List	42
Fault Block Accessory—Replacement Parts List	43



SAFETY FOR LIFE



Cooper Power Systems products meet or exceed all applicable industry standards relating to product safety. We actively promote safe practices in the use and maintenance of our products through our service literature, instructional training programs, and the continuous efforts of all Cooper Power Systems employees involved in product design, manufacture, marketing, and service.

We strongly urge that you always follow all locally approved safety procedures and safety instructions when working around high voltage lines and equipment and support our “Safety For Life” mission.

SAFETY INFORMATION

The instructions in this manual are not intended as a substitute for proper training or adequate experience in the safe operation of the equipment described. Only competent technicians who are familiar with this equipment should install, operate, and service it.

A competent technician has these qualifications:

- *Is thoroughly familiar with these instructions.*
- *Is trained in industry-accepted high- and low-voltage safe operating practices and procedures.*
- *Is trained and authorized to energize, de-energize, clear, and ground power distribution equipment.*
- *Is trained in the care and use of protective equipment such as flash clothing, safety glasses, face shield, hard hat, rubber gloves, hotstick, etc.*

Following is important safety information. For safe installation and operation of this equipment, be sure to read and understand all cautions and warnings.

Safety Instructions

Following are general caution and warning statements that apply to this equipment. Additional statements, related to specific tasks and procedures, are located throughout the manual.



DANGER: Hazardous voltage. Contact with hazardous voltage will cause death or severe personal injury. Follow all locally approved safety procedures when working around high and low voltage lines and equipment.

G103.3



WARNING: Before installing, operating, maintaining, or testing this equipment, carefully read and understand the contents of this manual. Improper operation, handling or maintenance can result in death, severe personal injury, and equipment damage.

G101.0



WARNING: This equipment is not intended to protect human life. Follow all locally approved procedures and safety practices when installing or operating this equipment. Failure to comply can result in death, severe personal injury, and equipment damage.

G102.1



WARNING: Power distribution equipment must be properly selected for the intended application. It must be installed and serviced by competent personnel who have been trained and understand proper safety procedures. These instructions are written for such personnel and are not a substitute for adequate training and experience in safety procedures. Failure to properly select, install, or maintain power distribution equipment can result in death, severe personal injury, and equipment damage.

G122.2

Hazard Statement Definitions

This manual may contain four types of hazard statements:



DANGER: Indicates an imminently hazardous situation which, if not avoided, will result in death or serious injury.



WARNING: Indicates a potentially hazardous situation which, if not avoided, could result in death or serious injury.



CAUTION: Indicates a potentially hazardous situation which, if not avoided, may result in minor or moderate injury.

CAUTION: Indicates a potentially hazardous situation which, if not avoided, may result in equipment damage only.



PRODUCT INFORMATION

Introduction

Service Information S260-75-1 provides installation, operation, and maintenance instructions for the Kyle® Type S automatic load-transfer control.

Read This Manual First

Read and understand the contents of this manual and follow all locally approved procedures and safety practices before installing or operating this equipment.

Additional Information

These instructions cannot cover all details or variations in the equipment, procedures, or process described, nor to provide directions for meeting every possible contingency during installation, operation, or maintenance. For additional information, contact your Cooper Power Systems representative.

Acceptance and Initial Inspection

Each Type S control is completely assembled, tested, and inspected at the factory. It is carefully calibrated, adjusted, and in good condition when accepted by the carrier for shipment.

Upon receipt, inspect the carton for signs of damage. Unpack the control and inspect it thoroughly for damage incurred during shipment. If damage is discovered, file a claim with the carrier immediately.

Handling and Storage

Use care during handling and storage of the control. If the control is to be stored for any length of time prior to installation, provide a clean, dry storage area to minimize the possibility of mechanical damage.

ANSI Standards

Kyle reclosers are designed and tested in accordance with ANSI standards C37.60 and C37.85 and ANSI guideline C37.61.

Quality Standards

The Quality System at the Cooper Power Systems, Kyle Distribution Switchgear plant is ISO 9001 certified.

ISO 9001

CAN/CSA ISO 9001

BS EN ISO 9001

ANSI/ASQC Q9001

Description of Operation

The Type S control is designed for use primarily with Kyle Type VR, VLR, VRV, TSC, and C three-phase, load-break switches in automatic load-transfer schemes. In a typical scheme, service to a critical load is normally supplied from a preferred source. It is automatically switched to an alternate, standby source if the preferred source voltage is lost for any reason for a preset period of time. Upon restoration of the preferred source voltage, the load is automatically switched back to the preferred source, again after a predetermined time delay.

Typical Automatic Load-transfer Sequence using the Type S Control

- The load is transferred to the alternate source after a preset time delay, when the preferred source voltage is lost and normal voltage is present on the alternate source. Either Source I or Source II can be selected as the preferred source by a setting on the SOURCE PREFERENCE Switch, S4.
- The load is transferred back to the preferred source—after another preset time delay—when normal voltage is restored to the preferred source. The return transfer (from Source II to Source I) can be either non-parallel (alternate-source switch opens before preferred-source switch closes) or parallel (preferred-source switch closes before alternate-source switch opens). With parallel return the second interruption is eliminated; however, both sources must be in synchronism. The return transfer mode is selected by a setting on the SOURCE PREFERENCE switch, S4.

Variations in the Operation of the Type S Control

- **No-Preference Operation.** When either source is acceptable for continuous critical load supply. Upon loss of Source I voltage—and after a preset time delay—the load is automatically transferred to Source II, provided normal voltage is present on Source II. However, the load is not transferred back to Source I when voltage is restored, but remains on Source II until such time as Source II voltage is lost. Then an automatic nonparallel transfer to Source I is performed. (Accomplished by setting SOURCE PREFERENCE switch, S4, to NO PREF position.)
- **Hold on Alternate Source.** When placed to the HOLD ON ALTERNATE position, the S control will not automatically return to the preferred feeder. If the preferred feeder is energized, the S control can be manually transferred to the preferred feeder by momentarily moving S3 to the NORMAL position.

IMPORTANT: If Control Mode Switch S3 is placed in the “AUTO” position, the S-control will place the high-voltage transfer switches into the configuration that is currently selected by the Source Preference Switch S4. This may result in an unintended transfer. Make sure the desired state of the high-voltage transfer switches match the setting of S4 before returning S3 to the “AUTO” position.

- **Manual Operation of the S control.** The Source I and Source II high-voltage switches can be opened and closed independently to effect manual transfer from one source to the other. (Accomplished by setting OPERATION SELECTOR switch, S3, to MANUAL and operating MANUAL OPER. SOURCE I (S1) and MANUAL OPER. SOURCE II (S2) switches as required.)

In addition, a factory-installed fault block accessory will Block Transfer if loss of voltage is due to a fault on the load side of the high-voltage switches. When preferred source voltage is lost (due to the opening of the backup protective device)—and after the preset time delay—the preferred source switch will open and the fault block accessory will disable the S control to prevent closing either high-voltage switch into the fault. The S control must be manually reset before service to the load can be restored. The fault block option is a factory-installed accessory. The accessory is activated by over-current signals supplied by load-sensing current transformers built into special factory-modified Type VR, VLR, VRV, TSC, and CS high-voltage switches. It is also compatible with the PST-6 switchgear. The PST-9 switchgear does not require fault block.

Time Delay Selection

The time delay setting for preferred to alternate source transfer must be long enough to allow discrimination between permanent loss of voltage and temporary loss of voltage due to transient effects or reclosing intervals of backup protective reclosers or breakers. The time-delay required to override reclosing intervals is difficult to determine since voltage may be subnormal during the retarded timing operations of the backup device due to the presence of the fault. It is recommended that the time delay before transfer from preferred to alternate source is set to exceed the maximum cumulative time to lockout of the backup protective device. This approach assures that the transfer switch will not interrupt the current of a fault occurring on the load side of the switch.

The time delay for return from alternate to preferred source upon restoration of preferred source voltage should be set for an interval long enough to assure that service on the preferred source has been permanently restored.

When the control is programmed to operate in the “no-preference” mode, there are no preferred or alternate sources. Time delay intervals for transfer from Source I to Source II are governed by the left-hand Preferred to Alternate timer and for transfer from Source II to Source I by the right-hand Alternate to Preferred Timer. Settings of the two timers may be different because of difference in backup protection on the two sources.

PRE-INSTALLATION CHECK

Pre-Installation

 **WARNING:** This equipment is not intended to protect human life. Follow all locally approved procedures and safety practices when installing or operating this equipment. Failure to comply can result in death, several personal injury and equipment damage.

G102.1

 **WARNING:** Hazardous voltage. Never rely on the open position of the operating handle or the contact position indicator; it does not ensure that the line is deenergized. Follow all locally approved safety practices. Failure to comply can result in contact with high voltage, which will cause death or severe personal injury.

G123.1

The Type S automatic load-transfer control is programmed to customer's specifications and thoroughly tested before shipment from the factory. Perform the following pre-installation test setup and procedure to verify the operation of the standard S control.

Note: This procedure does not test complete control operation. This can be done only on a complete installation basis with the S control operating the high-voltage transfer switches.

Test Set-up

1. Connect a 120 Vac, 60 Hz power supply to terminals Z and G₂ of TB2 being absolutely certain that the grounded side of the power supply is connected to G₂.
2. Jumper terminal Z to Y to X to C to B to A.
3. When the 120 Vac power supply is turned on, all six phases are energized.
4. To simulate loss of voltage on any phase of either source, simply unscrew the appropriate fuse "FU" in the control.

Test Procedure

1. Check the indicating lamps by depressing the LAMP TEST switch (S6). All lamps on the front panel of the control (including fault block accessory if installed) should light with equal brilliance.
2. With phase Y and/or phase B energized, terminals 11 and 21 of TB1 will always show 120 Vac to ground (G₁ or G₂).
3. With OPERATIONS SELECTOR switch (S3) set to MANUAL, terminal 13 of TB1 will respond to the operation of MANUAL OPER. SOURCE I switch (S1) showing 120 Vac to ground when S1 is in the open position and 10 Vac, or less, when S1 is in the OFF and CLOSE positions. Terminal 23 of TB1 will show similar voltages to ground in response to the operation of MANUAL OPER.
4. When MANUAL OPER. SOURCE I switch (S1) is in the CLOSE position there should be 120 Vac

between terminal 15 of TB1 and ground. Similarly, when MANUAL OPER. SOURCE II switch (S2) is in the CLOSE position there should be 120 Vac between terminal 25 of TB1 and ground.

5. To check the response of the latching relay to automatic operation, proceed as follows:
 - A. Set OPERATION SELECTOR switch (S3) to AUTO.
 - B. Select the desired source preference and return mode with switch S4.
 - C. After waiting for a time in excess of the maximum transfer delay timer setting (to make sure the control is at rest), simulate a "lost" phase by unscrewing one of the preferred source fuses. Listen for relay clatter to recognize breaking the circuit.
 - D. As soon as phase voltage is lost, the PREFERRED TO ALTERNATE TIMER will start to run. Verify the LED timer is illuminated during operation.
 - E. When timing is complete, the latching relay (R1) will operate. Its position can be checked by the presence of 120 Vac at test terminals T-1 or T-2 on the front panel. 120 Vac between T-2 and T-3 (ground) means the latching relay has moved to that position which would connect the load to Source II if HV switches were connected to the control. 120 Vac at T-1 means the load would be connected to Source I.
 - F. Replace the removed fuse to restore preferred source power, observe operation of the ALTERNATE TO PREFERRED TIMER, and check the status of the latching relay (R1) when timing is completed.

Note: SOURCE PREFERENCE switch S4 cannot be in NO PEF position for this test.
 - G. Other modes of transfer can be checked by programming the control for the desired sequence, simulating loss of source voltage, observing resultant control operation, and checking the final position of the latching relay (R1).

6. Timer settings can be verified with a watch while performing the checks in preceding Step 5.
7. Switch I and Switch II position indicating lamps will not operate during this preinstallation check since the high-voltage transfer switches are not connected to the control.

Their operation can be verified by connecting a 100 ohm, 1 watt, resistor from TB1 terminals to ground as follows:

- SWITCH I OPEN lamp—terminal 15 to ground
- SWITCH I CLOSED lamp—terminal 24 to ground
- SWITCH II OPEN lamp—terminal 25 to ground
- SWITCH II CLOSED lamp—terminal 14 to ground

INSTALLATION INSTRUCTIONS

A typical automatic transfer scheme is illustrated in Figure 2.

Initial Programming

The control must be programmed with all necessary operating settings prior to operation with energized switchgear. For the desired settings refer to the **Operating Instructions** section in this manual.

Mounting the Control

Mount the S control in a convenient, accessible location. Maximum distances between the high-voltage transfer switches and potential sensing transformers and the control depends upon the size of the control cable wire and the length of various cable combinations. (See the **Interconnecting Cables** section in this manual.) Keep in mind that the longer the cable lengths, the greater the susceptibility to surge damage. Therefore, for optimum reliability and economy, locate the switches and transformers as near as possible to the control.

Mounting dimensions are provided in Figure 3.

- For pole-mounted installation, a hole and keyway in the control mounting bracket accommodates a 5/8" bolt.
- For substation installation, the control is factory installed. Leveling is not required.

Grounding the Control

 **WARNING:** Hazardous voltage. Solidly ground all equipment. Failure to comply can result in death, severe personal injury, and equipment damage.

T223.2

The control cabinet must be grounded. A grounding connector on the underside of the cabinet will accommodate No. 14 solid through No. 4 stranded conductors.

For effective surge protection all control and power conductors for the S control must be routed parallel to a corresponding ground path. For example, the AC power supply for the control should be parallel to and equal in length to the transformer ground path. The control cable should be parallel to and routed close to the switchgear ground path.

Before Placing the Control and Switchgear into Service

 **CAUTION:** Equipment misoperation. Do not energize this equipment until all control settings have been properly programmed and verified. Refer to the Control Programming and Operation section of this manual for programming procedures. Failure to comply can result in misoperation (unintended operation), equipment damage, and personal injury.

G118.1

Prior to placing the control and switchgear into service, the following installation procedures must be properly completed and verified:

1. Control properly mounted for the installation.
2. Equipment installed according to all locally approved standards and practices.
3. Control and switchgear properly grounded in accordance with guidelines in this manual.
4. AC power connected to the control.
5. All control programming entered and verified by appropriate personnel.

Equipment Required

The following equipment is required for a load-transfer installation:

Type S Load-Transfer Control

The control, with or without the fault block accessory, is housed in a cabinet whose outline and mounting dimensions are shown in Figure 3. The control cabinet can be mounted on a pole or substation structure. Leveling is not required. Both the cabinet door and the hinged front panel are equipped with hold-open latches to prevent them from swinging in the open position.

Motor Operated Switches

The three-phase, load break switches require a special wiring accessory for operation with the Type S control. In addition, if fault block is provided, the switches must be equipped with 1000:1 ratio current transformers also available as a factory-installed switch accessory. See the switch installation manual for overall and mounting dimensions and for wiring diagrams.

Potential Transformers

Three-phase voltage sensing is required for control operation. Transformer connections and voltages for various distribution system connections are shown in Figure 5. The voltage sensing relays of the Type S control drop out on a decreasing voltage at 75 volts (min) and pick up on an increasing voltage at 97 volts (max). The control requires 120 Vac, 60 Hz, 500 VA (min) to operate the transformer switches. Quiescent power dissipation at 120 Vac is 18 watts.

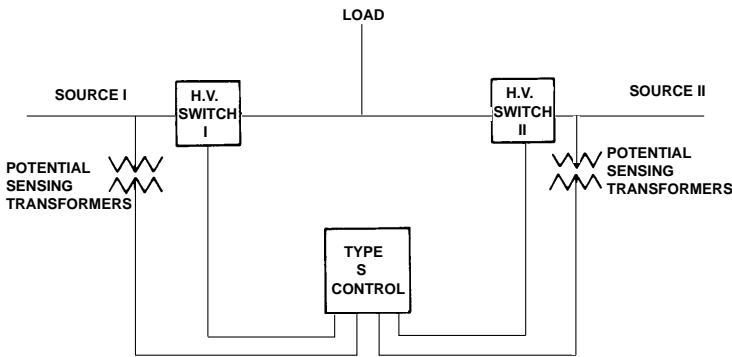

Figure 2.
Typical Type S control load-transfer scheme.

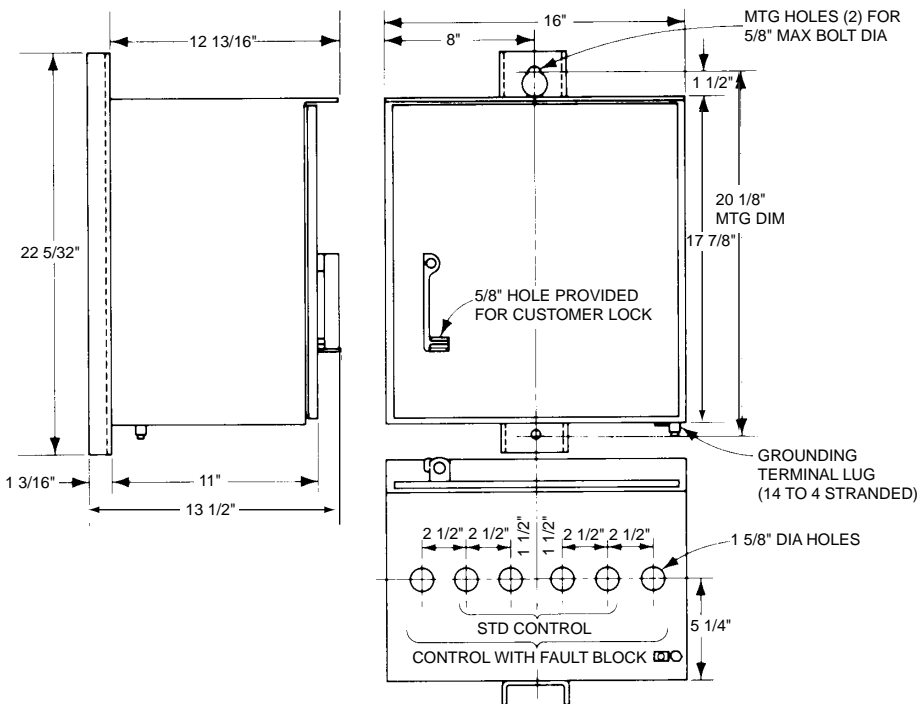

Figure 3.
Outline and mounting dimensions.

TABLE 1
Reaction and Transition Times of Cooper Power Systems Motor-Operated Switches

Switch	First Switch Reaction Time*	Transition Time**	Direction of Transfer (Source to Source)	Type of Transition
VR, VLR, VRV (standard)	2.5 to 3.5 cycles	10 sec (approx)	I to II	No paralleling of sources
VR, VLR, VRV (standard)	2.5 to 3.5 cycles	10 sec (approx)	II to I	No paralleling of sources
VR, VLR, VRV (standard)	10 sec (approx)	1.0 to 1.5 cycles	II to I	Paralleling of sources on return to preferred source
VR, VLR, VRV (quick close)	2.5 to 3.5 cycles	6 to 7 cycles	I to II	No paralleling of sources
VR, VLR, VRV (quick close)	2.5 to 3.5 cycles	6 to 7 cycles	II to I	No paralleling of sources
VR, VLR, VRV (quick close)	4.0 to 5.5 cycles	1.0 to 1.5 cycles	II to I	Paralleling of sources on return to preferred source
TSC	7 to 8 sec	7 to 8 sec	I to II	No paralleling of sources
TSC	7 to 8 sec	7 to 8 sec	II to I	No paralleling of sources
TSC	7 to 8 sec	7 to 8 sec	II to I	Paralleling of sources on return to preferred source
PST-6, PST-9	2.0 to 3.0 cycles	5.0 to 6.0 cycles	I to II	No paralleling of sources
PST-6, PST-9	2.0 to 3.0 cycles	5.0 to 6.0 cycles	II to I	No paralleling of sources
PST-6, PST-9	5.0 to 6.0 cycles	2.0 to 3.0 cycles	II to I	Paralleling of sources on return to preferred source

* Time from expiration of time delay to first opening (or closing) of high-voltage switch. Add approximately one cycle to the values shown to allow for Type S control relay operating time.

** Time-load tap is disconnected or paralleled depending on type of transition used.

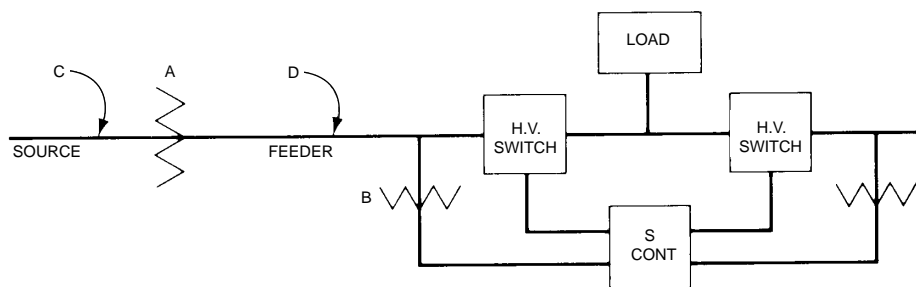

Phase Voltage at the Three-Phase Sensing Type S Load Transfer Control as Related to System and Sensing Transformer Connections

System Connections (Substation Transformer Bank) (Point A)		Sensing Transformer Connections (Point B)		% Normal Three-Phase Voltage* Sensed at S Control for Loss of One Phase at		Sensing Transformer Connections (Point B)
Source Side	Feeder Side	3 Transformers		Source C	Feeder D	2 Transformers
4-Wire (GND)	3-Wire			100-100-100**	100-50-50	
3-Wire (UNGND)	3-Wire			87-87-0	100-50-50	Not Recommended
4-Wire (GND)	4-Wire (GND)			100-58-58	100-58-58	
				100-100-0	100-100-0	—
3-Wire (UNGND)	3-Wire (UNGND)		(Pref)	100-50-50	100-50-50	
				87-87-0	87-87-0	—
3-Wire	3-Wire			100-50-50	100-50-50	
3-Wire	3-Wire (UNGND)			87-58-0†	100-50-50	Not Recommended
3-Wire	4-Wire (GND)		(Pref)	100-50-50	100-100-0	—
				87-58-0†	100-87-58†	Not Recommended

* Assuming no feedback from the load
 ** Bank operates open wye-delta; requires two primary phases open for sensing
 † Voltage may vary from 87 to 58% depending on load

Figure 4. Phase voltage at the three-phase sensing Type S load-transfer control.

Customer Connections

Connection Diagram

CAUTION: Equipment Damage. Do not drill connection holes into the top of the cabinet. Connection holes in the top of the cabinet will allow moisture to seep into the control and damage the components or cause control misoperation. Failure to comply will void the control's factory warranty.

T249.0

Diagrams for interconnecting the load-transfer control with the high-voltage switches and potential transformers are shown in Figures 5 through 8. The diagrams show

the internal wiring between the terminal blocks and the input and output receptacles on the control (available as an accessory) and the external wiring between the control, transfer switches, and potential transformers. If the control is not equipped with the plugs and receptacles accessory, the cables are wired directly to the terminal blocks in the control. For the physical location of terminal blocks, refer to Figure 27.

Note: Internally wired receptacles and mating plugs for the switch operators and current sensing transformers on the switch end of the cables are provided as standard with the switches.

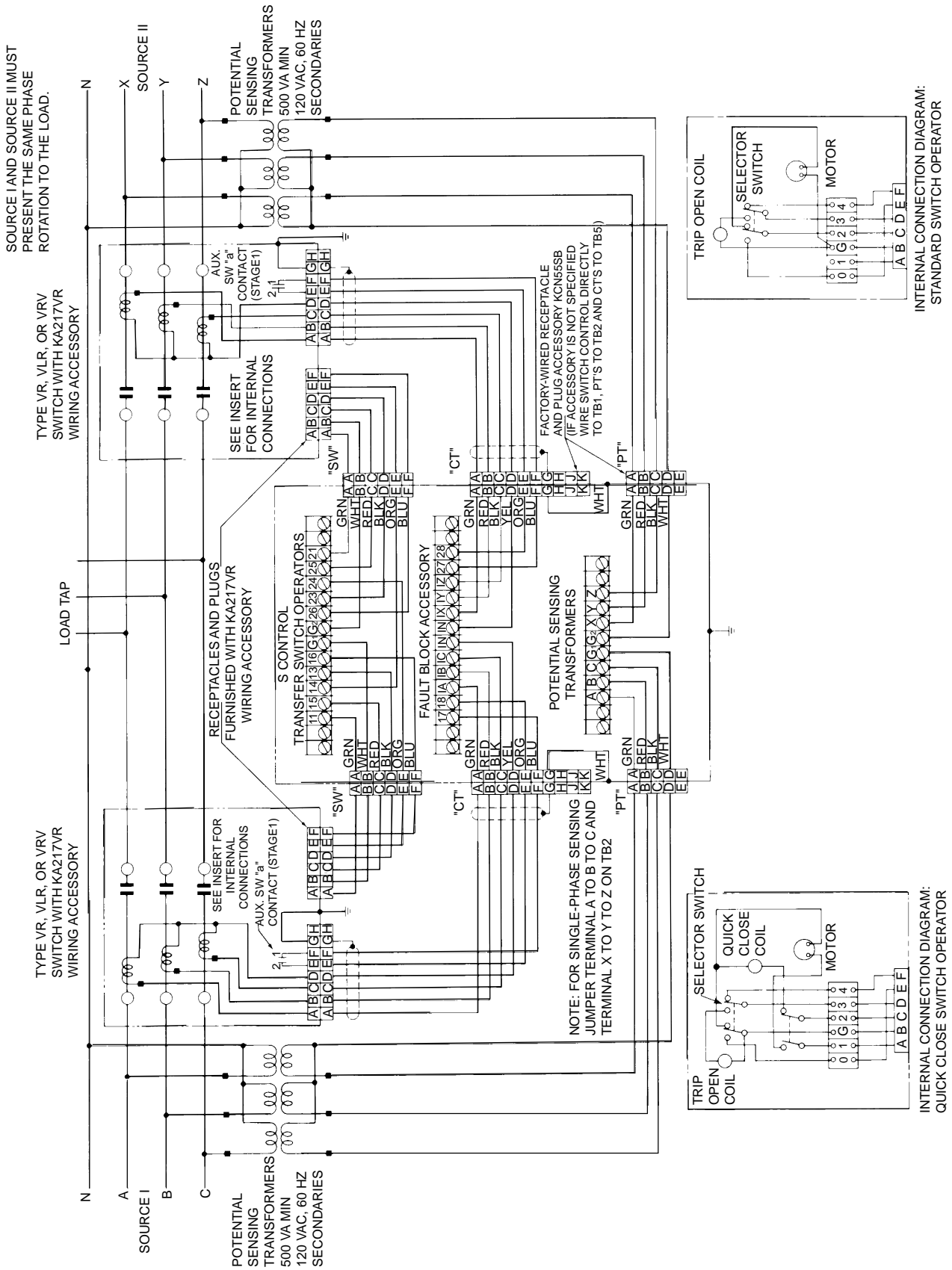

Figure 5. Connection diagram for Type S load-transfer control (with fault block accessory) operating a Type VR, VLR, or VRV three-phase switch. (The transformer cutouts, tap fuses, reclosers, and arresters are not shown.)

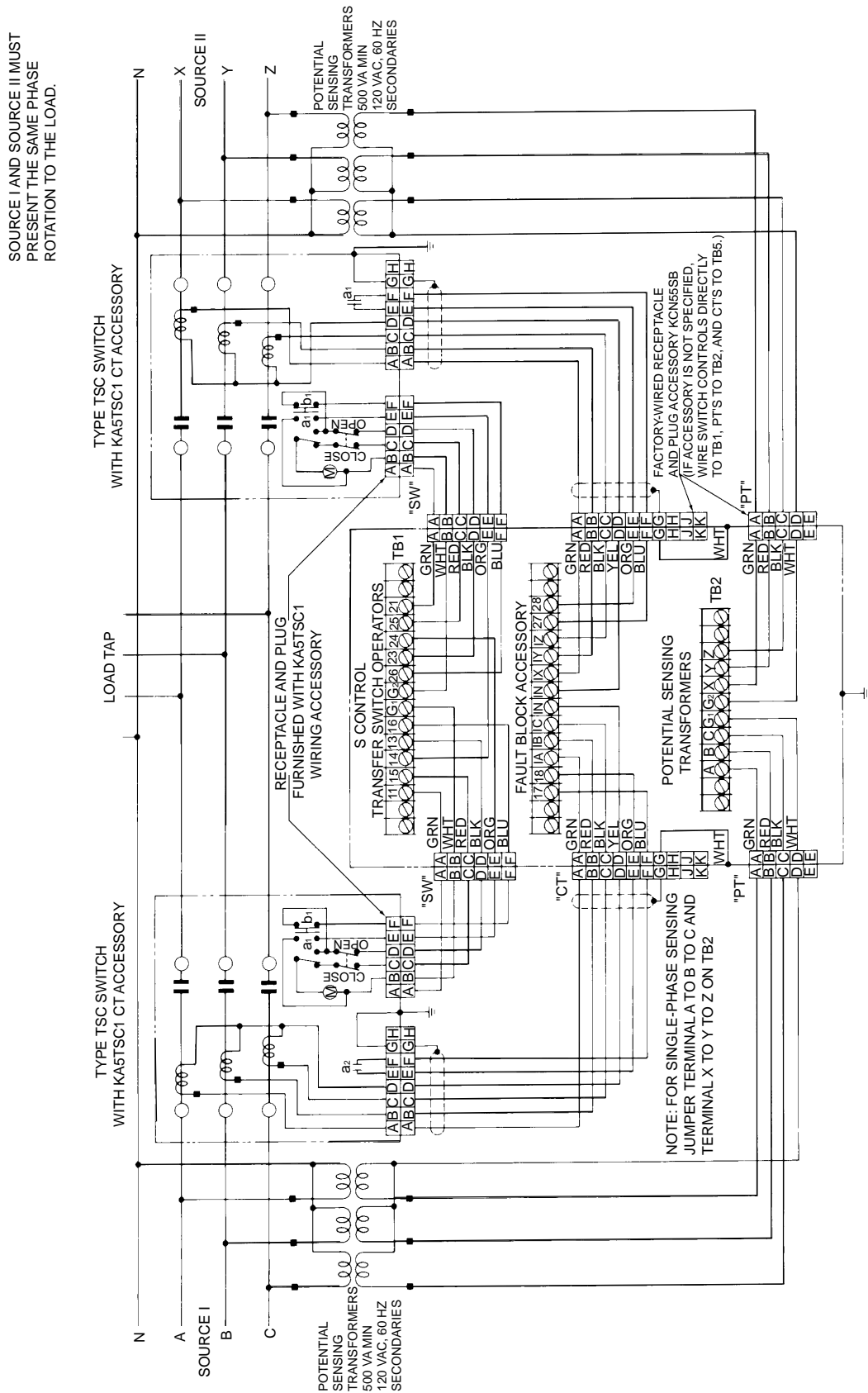

Figure 6. Connection diagram for Type S load-transfer control (with fault block accessory) operating the Type TSC three-phase switch. (The transformer cutouts, tap fuses, reclosers, and arresters are not shown.)

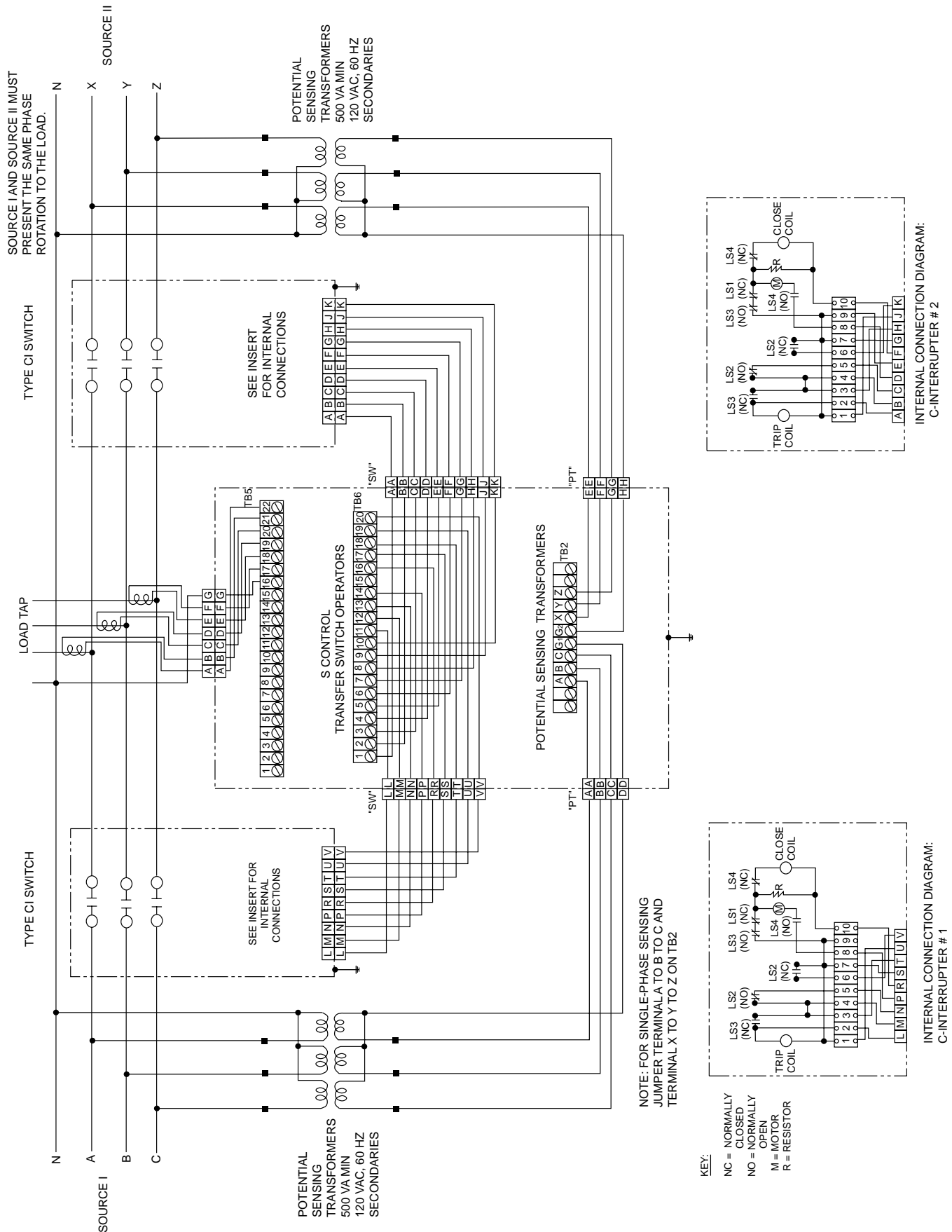

Figure 7. Connection diagram for Type S load-transfer control operating the Type PST-6 switch. (The transformer cutouts, tap fuses, reclosers, and arresters are not shown.)

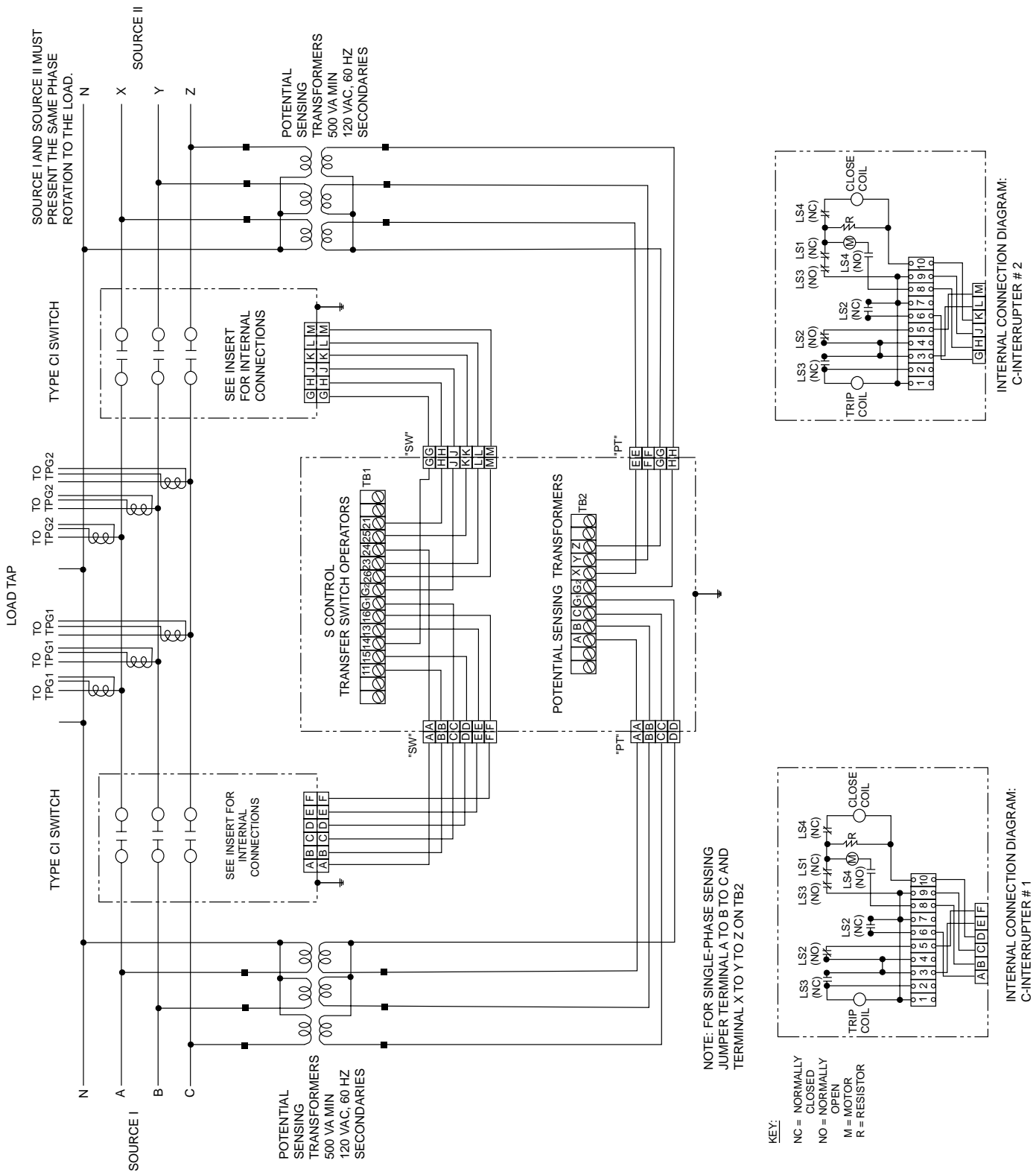

Figure 8. Connection diagram for Type S load-transfer control operating the Type PST-9 switch. (The transformer cutouts, tap fuses, reclosers, and arresters are not shown.)

Interconnecting Cables

Interconnecting cable conductor size is dependent upon the distance between the control, switches, and potential transformers. Maximum lengths of various cable combinations for No. 18 through No. 12 AWG conductors are shown in Table 2. The longest combination for the particular installation will determine the minimum conductor size. All cables are to be the same conductor size.

Note: If the control is equipped with the fault block accessory, see Table 3 for additional cable length limitations.

On the switch end, the cables are wired to connector plugs provided as standard with the switches. On the S control end, the cables are wired either directly to terminal blocks in the control or to connector plugs provided with the Plugs and Receptacles accessory. Figure 9 shows the location of the accessory plugs and receptacles in the bottom of the control cabinet. See the appropriate switch installation manual for the location of the plugs and receptacles on the switch.

Switch Cable

A conductor cable is required between the S control and each high-voltage switch to operate the switches. This cable is wired to a socket plug at the switch end and to either a plug or TB1 at the control end. Pin identification, and cable OD and maximum conductor size accommodated by the plugs are shown in Figures 10 and 11.

Potential Transformer Cable

A four-conductor cable is required between the S control and the potential transformers to transmit source voltage intelligence and to supply operating power for the control. This cable is wired to a five-pin socket plug or TB2 at the control end. Pin socket identification, cable OD, and maximum conductor size accommodated by the plugs are shown in Figure 12.

Note: Connectors are not supplied for the transformer end of the cable.

TABLE 2
Maximum Control Cable Lengths

Cable Wire Size (AWG)	Maximum Length of Control Cable Combinations (ft.)	
	VR, VLR, or VRV Switches A+B+D or C+B+D	TSC Switch A+B or A+D or C+B or C+D
18	1450	1250
16	2300	2000
14	3700	3200
12	5900	5050

Note: The control cable lengths are not applicable for the C switch and the PST switch.



Figure 9.
Plugs and receptacles accessory.

020079KM

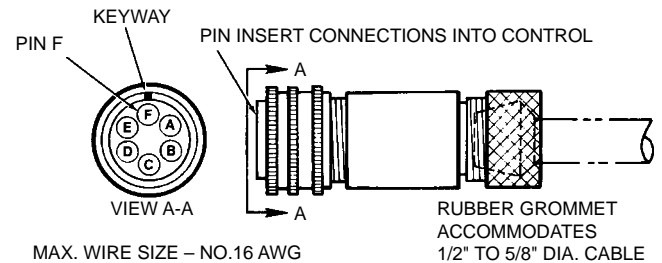

Figure 10.
Switch cable plug for VR, VLR, VRV, and TSC.

PST-6 8, 7, & 19 PIN RECEPTACLES
PST-9 8 & 19 PIN RECEPTACLES

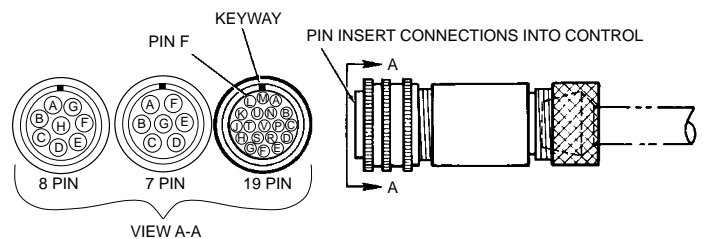

Figure 11.
Switch cable plugs for PST-6 and PST-9.

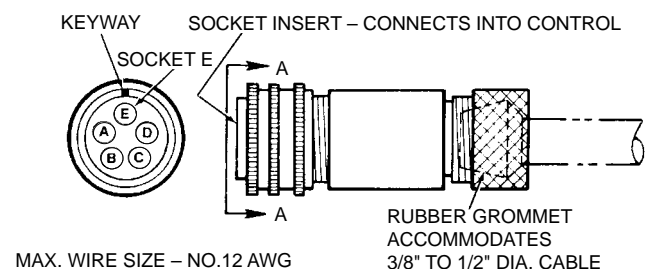

Figure 12.
PT cable plug.

Fault Block Shielded Cable

Table 3 shows the maximum distance between the control and the high-voltage switches for a range of conductor sizes and fault-block settings. The table is based on conductor voltage drop and saturation of the current sensing transformers in the switch. Lower actuating levels and lower multipliers could allow longer lines. However, the limitation on switch control cable lengths, Table 2, preclude their use.

Shielded cable is required between the transfer switches and the S control for operating the fault block accessory.

IMPORTANT: Only shielded cable is to be used on fault block accessory and is mandatory to validate the Cooper Power Systems warranty. Use of a non-shielded cable could result in misoperation.

The shield must be grounded to the equipment housing at both the switch and control ends. Shield connections are made at connector plug pin or socket as shown in Figure 13. This pin mates with the receptacle pin or socket which is grounded in the switch and in the control as shown in Figures 6 and 8.

TABLE 3
Fault Block Cable Limitations

Phase Actuating Current Level (Amps)	Conductor Size (AWG)	Max. Distance in Feet Between Switch and S Control		
		For X 8 Multiplier	For X 6 Multiplier	For X 4 Multiplier
640	18	600	1000	1800
640	16	950	1600	2900
640	14	1500	2550	4600
640	12	2400	4000	7300
448	18	1100	1700	—
448	16	1800	2700	—
448	14	2800	4300	—
448	12	4500	6850	—
320	18	1800	—	—
320	16	2900	—	—
320	14	4600	—	—
320	12	7300	—	—

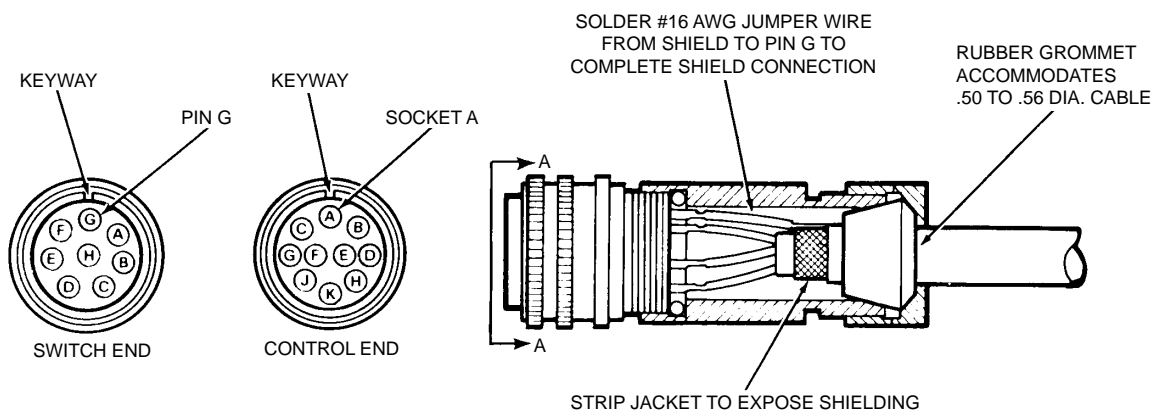

Figure 13.
Fault block cable plug.

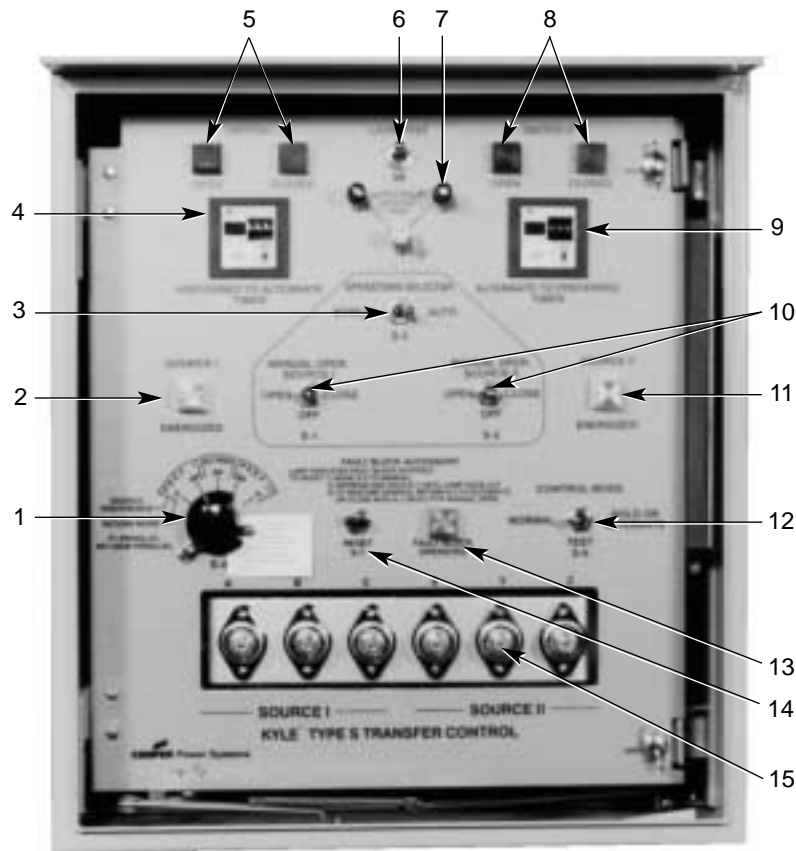

Figure 14.
Type S control front panel.

020076KM

TABLE 4
Description and Use of Operating Controls and Indicators

Index No. Figure 2	Description	Purpose and Use
1	SOURCE PREFERENCE AND RETURN MODE Switch (S4) (See Note A)	Selects either Source I (PREF I) or Source II (PREF II) as the preferred source, or no preference (NO PREF). Also selected parallel (P) or non-parallel (NP) return mode.
2	SOURCE I ENERGIZED lamp	Indicates all three phases of Source I are energized.
3	OPERATION SELECTOR Switch (S3)	Programs control for either AUTOMATIC or MANUAL operation.
4	PREFERRED TO ALTERNATE TIMER	Determines time delay before transfer to alternate source when preferred source voltage is lost.
5	SWITCH I OPEN and CLOSED lamps	Indicates status of Source I high voltage switch.
6	LAMP TEST switch (S6)	Tests all indicating lamps on front panel.
7	LATCH RELAY STATUS TEST terminals (T1—T2—T3)	Provides electrical access to both sides of latch relay to determine if control is in Source I or Source II mode.
8	SWITCH II OPEN and CLOSED lamps	Indicates status of Source II high voltage switch.
9	ALTERNATE TO PREFERRED TIMER	Determines the time delay before transfer to preferred source when preferred source voltage is restored.
10	MANUAL OPER. SOURCE I and MANUAL OPER. SOURCE II switches (S1 and S2)	Provides means to OPEN and CLOSE Source I and Source II transfer switch upon manual command, when S3 is in MANUAL position.
11	SOURCE II ENERGIZED lamp	Indicates all three phases of Source II are energized.
12	CONTROL MODE switch (S5)	Blocks automatic return transfer to preferred sources (HOLD ON ALTERNATE); also enables control to be operated without operating the high voltage transfer switches (TEST).
13	FAULT-BLOCK OPERATED lamp	Indicates fault-block has operated (part of fault-block accessory).
14	RESET switch (S7)	Resets the control after a fault block operation (part of fault-block accessory). S3 must be in MANUAL position.
15	Fuses	Voltage input of all three phases of both Source I and Source II are fused for 10A-125 vac; white button shows on front of fuse if fuse blows.

Note A — Tab provided to lock switch knob in set position; stop screw prevents inadvertent selection of parallel return transfer mode.

OPERATING INSTRUCTIONS

 **DANGER:** Hazardous voltage. Contact with hazardous voltage will cause death or severe personal injury. Follow all locally approved safety procedures when working around high and low voltage lines and equipment. G103.3

 **WARNING:** Hazardous voltage. Never rely on the open position of the operating handle or the contact position indicator; it does not ensure that the line is deenergized. Follow all locally approved safety practices. Failure to comply can result in contact with high voltage, which will cause death or severe personal injury. G123.1

Before energizing the installation, an understanding of the functions of the operating controls and indicating lights is essential. (See Table 4 and Figure 14).

Initial Operation

To place the automatic transfer scheme into service, proceed as follows:

CAUTION: Equipment misoperation. Source I and Source II high voltage switches can be paralleled in the manual operation mode even if SOURCE PREFERENCE switch, S4, is set for NP (non-parallel operation). Make sure both sources are in synchronism if a manual parallel operation is to be performed. Failure to comply can result in misoperation (unintended operation) and equipment damage. T304.0

1. The switches on the front panel should be positioned as follows:
 - A. S1 (MANUAL OPER. SOURCE I) — OFF
 - B. S2 (MANUAL OPER. SOURCE II) — OFF
 - C. S3 (OPERATION SELECTOR) — MANUAL
 - D. S4 (SOURCE PREFERENCE AND RETURN MODE) — set to the desired mode of operation.
 - E. S5 (CONTROL MODE) — NORMAL
2. Set the PREFERRED TO ALTERNATE TIMER and ALTERNATE TO PREFERRED TIMER as required. (See **Time Delay** section in this manual.)
3. Check that all installation connections are complete as shown in the appropriate connection diagram Figures 5 through 8.
4. Make sure both high-voltage transfer switches are open.
5. With all six fuses in place, energize both power sources to the control.
 - A. SOURCE I ENERGIZED lamp should be on.
 - B. SOURCE II ENERGIZED lamp should be on.
 - C. SWITCH I OPEN lamp should be on.
 - D. SWITCH II OPEN lamp should be on.
6. Depending upon which source is the preferred source, momentarily operate either S1 or S2 to the CLOSE position. The appropriate switch will close to energize the load and its status indicating lights will transfer from OPEN to CLOSED.
7. Place the OPERATION SELECTOR SWITCH (S3) to AUTO. The S control is in service. No further operation will occur until the preferred source voltage is lost.

Timer Settings

IMPORTANT: Put control in manual mode prior to changing timer setting. There is no fault current protection when in manual mode. Failure to comply can cause unintended operation.

The two digital timers are identical. One timer controls the time required to transfer from the preferred source to the alternate source, the other timer controls the time to transfer from the alternate source to the preferred source.

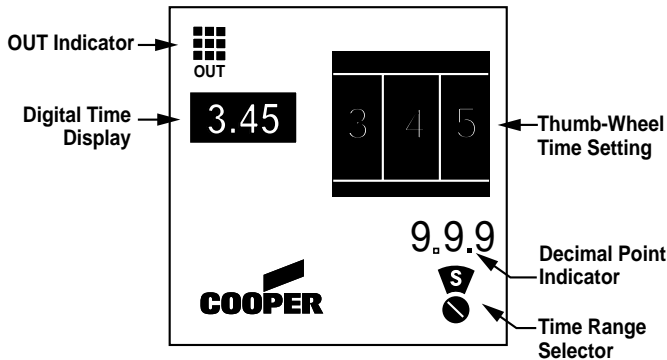

Figure 15.
Digital Timer and Time Ranges.

The two digital timers feature the following informational indicators and adjustment controls:

Digital Time Display

LED displays the time count. The timer counts up until it reaches the time delay setting of the thumbwheel switch.

Time Range Selector

The time range selector switch can be set to six different positions with a flat screwdriver. Each position indicates a time range. See chart below. The time range selector is preset to the time range of 0.1 to 99.9 seconds.

	9.99	99.9	999	99.9	999	99.9
Indication						
Time Range	0.01 to 9.99 sec	0.1 to 99.9 sec	1 to 999 sec	0.1 to 99.9 min	1 to 999 min	0.1 to 99.9 hours

Thumbwheel Time Setting

IMPORTANT: Thumb-wheel time setting must be securely turned. Incomplete setting may cause timer malfunction and control misoperation.

Set the desired time delay setting by rotating the thumbwheel switch. For example, if the thumbwheel time setting is 345 the timer will time out in 34.5 seconds based off the time range selector setting of 0.1 to 99.9 seconds.

Note: The thumb-wheel time setting, which does not turn infinitely, should not be turned beyond the limit.

Out Indicator

The out indicator briefly lights to signal completion of a timing interval and confirm that the timer has operated.

Normal Operation

The control will react to ongoing line voltage conditions and operate automatically as programmed. If equipped with the fault block accessory, transfer to the alternate source may be prevented when loss of voltage is due to a load-side fault. See **Fault Block Operating Instructions** section for procedure to restore service.

THEORY OF OPERATION —BASIC S CONTROL

Refer to Figures 16 and 17 for the following sections:

Voltage Sensing

The S control will transfer the load to an alternate source when one or more phases of the preferred source is lost, provided normal voltage is present on all three phases of the alternate source. To perform this function, the control requires three-phase, low-voltage (120 Vac) input from both the preferred and alternate sources of power. Input from Source I is connected to terminals A, B, C and G1 of TB2, and input from Source II is connected to terminals X, Y, Z and G2.

Each of the three input phase leads for both Source I and Source II is shunted to ground by a capacitor-varistor combination to provide surge protection to the control. On the preferred source side of the voltage sensing circuitry, the input lines then pass through 10 Amp fuses to the voltage sensing relays: R2 (Phase A), R9 (Phase B) and R10 (Phase C). R9 and R10 are connected directly to the input while N.O. contacts of R9 and R10 are in series with the R2 coil. Thus, R2 can be energized only if all three incoming phase voltages are above a predetermined value (approximately 97 volts). A similar arrangement is used for the alternate source sensing relays. R6 can be energized only if R7 and R8 are energized. The transfer bus across the top of the schematic diagram), which provides the operating power for the control is normally energized from Phase Y. If R7 drops out, due to loss of Phase Y, R11 will be energized from Phase B (through N.C. contact of R7) to re-energize the transfer bus. The contacts of R7 and R11 are so connected that the transfer bus can never be simultaneously energized from both B and Y phases.

Automatic Transfer, Preferred to Alternate

The following assumptions are made:

- OPERATION SELECTOR switch (S3) is in AUTO.
- SOURCE PREFERENCE and RETURN MODE switch (S4) is in PREF I-P (Terminal 2 of each deck connected).
- CONTROL MODE switch (S5) is in NORMAL.
- S control is in a quiescent state.
- Source I high-voltage transfer switch (SW-I) is closed and Source II high voltage transfer switch (SW-II) is open.

Note: The actuators of both high-voltage transfer switches are shown in the switch open position on the schematic diagram. Following each opening operation, the motor recharges the actuator springs and the cutout switch returns to the position shown in the schematic. However, when the high voltage transfer switch is closed, the selector switch of the actuator mechanism is opposite to that shown in the schematic.

If one or more phases of the preferred source (Source I) are lost, R2 will drop out and the SOURCE I ENERGIZED lamp (L1) will go out. N.C. contacts 1-7 of R2 close completing the circuit to the PREFERRED TO ALTERNATE TIMER (TM1) through 4-7 of R6 (which is energized), 7-4 of R1, and deck J of S4. When TM1 times out, its 5-6 contacts close to energize the coil of R1 in the reset direction causing R1 to transfer. Diodes in the circuit of this single-coil magnetically held relay determine whether “latching” or “resetting” occurs.

The transfer of R1 energizes the trip coil of Source I high-voltage transfer switch (SW-I) as follows:

Transfer bus voltage passes through terminals 5-1 of S3, contact 9-3 of energized R1, and terminals 4-3 of S5. It is then impressed on N.C. contact 7-2 of R4 and passes through deck B of S4 to output terminal 13 of TB-1. Terminal 13 is connected to the internal selector switch in the actuator of SW-I (which is closed when SW-I is closed), through the trip coil to ground (terminal G).

After SW-I has opened, the selector transfers to connect terminal 3 to terminal 4, which energizes terminal 16 of TB1. In turn contacts 2-6 of S3, deck C of S4, and terminal 25 of TB-1 are energized to operate the close coil of SW-II and close the switch.

SW-I will now remain open and SW-II closed until Source I voltage is restored.

Return Transfer, Parallel Transition

When Source I power is restored on all three phases, R2 will pick up and Source I Energized lamp (L1) will light. Contact 9-6 of R2 closes to energize ALTERNATE TO PREFERRED TIMER (TM-2) through contact 8-2 of R1, and deck K of S4. After TM2 times out, its contacts 5-6 close to energize the coil of R1 through diode DL in the latching direction causing R1 to transfer.

The transfer of R1 energizes the close coil of SW-I as follows:

Transfer bus voltage passes through terminals 5-1 of S3, contacts 9-6 of latched R1, and terminals 5-6 of S5. It is then impressed on N.C. contact 7-2 of R5 and passes through deck A of S4 to output terminal 15 of TB-1. This activates the close coil in SW-I. When SW-I closes, its auxiliary contact “a” closes to energize R5 (via TB1-24 and deck E of S4). Contact 7-5 of R5 closes to energize TB1-23 through deck D of S4. Voltage at TB1-23 will actuate the trip coil of SW-II to open the Source II high-voltage transfer switch.

Note: The Source I high-voltage switch (SW-I) closes before the Source II high-voltage switch (SW-II) opens to effect a parallel return transition. SW-I will now remain closed and SW-II open until Source I voltage is lost or a change of control settings is made.

Return Transfer, Non-Parallel Transition

The following assumptions are made:

- SOURCE PREFERENCE and RETURN MODE switch (S4) is in PREF I-NP (Terminal 3 of each deck connected).
- Source I has lost one or more phases and the load has been transferred to Source II as previously described (SW-I open and SW-II closed).
- Control is in a quiescent state with latching relay R1 in the reset position (contacts 9-3 and 8-2 closed) and R2 is deenergized.

When Source I power is restored on all three phases, R2 will pick up, closing its contact 9-6, and energize the ALTERNATE TO PREFERRED TIMER (TM-2) through contact 8-2 of R1, and deck K of S4. After TM-2 times out, its 5-6 contact closes to energize the coil of R1 through diode DL in the latching direction causing R1 to transfer, closing its 6-9 contact.

In this case, the trip coil of SW-II is immediately energized through the following circuit:

Terminals 5-1 of S3, N.C. contact 9-6 of R1, terminals 5-6 of S5, N.C. contact 7-2 of R5, and deck D of S4 to output terminal TB1-23 to activate the trip coil of SW-I and open to Source II high-voltage transfer switch.

When SW-II opens, its selector switch transfers to impress the voltage at TB1-23 onto TB1-26 which, in turn, energizes TB1-15 through terminals 3-7 of S3 and deck A of S4. Voltage at TB1-15 will actuate the quick-close coil of SW-I to close the Source I high-voltage switch.

Note: In this instance, the Source II high voltage switch (SW-II) opens before the Source I high voltage switch closes, to effect a non-parallel return transition. SW-I will now remain closed and SW-II open until Source I voltage is lost or a change is made in the control settings.

No Preference Mode

Assume the Source I high-voltage switch (SW-I) is closed and Source II high-voltage switch is open. With the SOURCE PREFERENCE and RETURN MODE switch (S4) in NO PREF-NP (Terminal 4 of S4 connected), loss of Source I voltage on one or more phases will open the Source I high-voltage switch (SW-I) as described in the Automatic Transfer, Preferred to Alternate section of this discussion.

Upon restoration of Source I voltage, R2 is re-energized. However, due to the positioning of decks G and H of S4, neither timer can be energized since both the N.C. contacts 1-7 of R2, and 9-3 of R6 are open (both relays are energized).

The S control is now in a quiescent state with SW-II closed and SW-I open. This condition will continue until either Source II is lost or a change is made in the control settings. If Source II is lost, delay in transfer to Source I will be timed by TM-2.

Preferred Source II Mode

With the SOURCE PREFERENCE and MODE switch (S4) in either PREF II-P (Terminal 6 of S4 connected), or PREF II-NP (Terminal 5 of S4 connected) the description of operation is similar to the "Automatic Transfer, Preferred to Alternate" and "Return Transfer, Parallel Transition" or "Return Transfer, Non-Paralleled Transition" as previously described except that Source II is the preferred source (controlled by SW-II) and Source I is the alternate source (controlled by SW-I).

Control Mode Switch, S5

If S5 is placed in the center-off TEST position, there is no circuit to either the close or trip coils of either high-voltage transfer switch. This position of S5 is used to check sensing circuitry, timers, and the latching relay without affecting the status of the high-voltage switches.

If S5 is placed in the HOLD ON ALTERNATE position, return transfer will not occur after preferred source voltage is restored. Assume the S3 is in AUTO, S4 is in PREF I-P, and the S control is in the quiescent state with Source I high voltage (SW-I) closed and Source II high-voltage switch (SW-II) open. Upon loss of Source I, R2 will again initiate a transfer of the latching relay R1 as previously described, followed by the opening of SW-I and the closing of SW-2. The S control is now in a quiescent state in which SW-2 will remain closed and SW-I will remain open even when Source I power is restored. When Source I is reenergized, R1 will transfer back to the latch position and close its contact 9-6. However, because deck L of S4 is open, power cannot be provided to the trip coil of SW-II or the close coil of SW-I.

Manual Control

When the OPERATION SELECTOR switch (S3) is placed in MANUAL, it connects the MANUAL OPER. SOURCE I switch (S1) and the MANUAL OPER. SOURCE II switch (S2) to the transfer bus. Power can then be supplied to either the close or trip coils of either SW-I or SW-II. Contacts 3-7 and 2-6 of S3 are opened in the MANUAL position so that opening of one high-voltage transfer switch does not cause automatic closing of the other. In the manual mode of operation, it is possible to have both high-voltage switches open, either switch closed, or both switches closed.

Indicating Lamps

The LAMP TEST switch (S6) is provided for checking the various incandescent indicators on the front panel of the S control. In the closed position, all the lamps will be energized through a diode network to check their condition.

In the open position, the diode network isolates the lamps from the test switch so that it has no effect on normal circuit operation.

TROUBLESHOOTING—BASIC S CONTROL

CAUTION: Equipment misoperation. Do not energize this equipment until all control settings have been properly programmed and verified. Refer to the Control Programming and Operation section of this manual for programming procedures. Failure to comply can result in misoperation (unintended operation), equipment damage, and personal injury. G118.1

WARNING: Hazardous voltage. Solidly ground all equipment. Failure to comply can result in death, severe personal injury, and equipment damage. T223.2

General

This troubleshooting guide is intended to assist in localizing problems that may be encountered in the operation of the load-transfer scheme. After the problem area has been localized, general troubleshooting and circuit tracing techniques can be used to pinpoint the cause. A fundamental understanding of the basic operation is essential in carrying out these troubleshooting procedures. (See **Theory of Operation** section.)

Schematic diagrams, Figures 16 and 17, are used as references throughout this guide. The physical location of the various circuit components and terminals are identified in Figure 27.

Remove the Control from Service

DANGER: Hazardous voltage. Contact with hazardous voltage will cause death or severe personal injury. Follow all locally approved safety procedures when working around high and low voltage lines and equipment. G103.3

The following warning only applies to controls equipped with the Fault Block Accessory:

WARNING: Hazardous Voltage. De-energize switchgear before attempting to disconnect control cable from control. Failure to do so may result in contact with high voltage pulse (300V peak) from the CT protection circuit. Failure to de-energize switchgear can result in contact with high voltage, which will cause death or severe personal injury. G124.0

1. De-energize Source I and Source II voltage.
2. Disconnect cables from the control.

Basic Troubleshooting

A quick check of the basic transfer operation while the control is in service can be made using the following procedure:

Source I or Source II Preferred Operation

1. Set CONTROL MODE switch (S5) to TEST. This will remove the control from service and allow it to operate without operating the high-voltage transfer switches.
2. Check LATCH RELAY STATUS TEST terminals (T-1, T-2) to ground (T-3). 120 Vac at T-1 indicates the control is in Source I mode; 120 Vac at T-2 indicates the control is in Source II mode. Check if this agrees with the SOURCE PREFERENCE switch setting.
3. Remove preferred source voltage by unscrewing one of the phase fuses from the applicable source. The PREFERRED TO ALTERNATE TIMER will start.
4. When the timer runs out, the latch relay (R1) will transfer; indicated by a transfer of the 120 Vac signal at the test terminals.
5. Replace the removed fuse to re-energize the preferred source. The ALTERNATE TO PREFERRED TIMER will start.

IMPORTANT: If Control Mode Switch S5 is placed in the "Normal" position, the S-control will place the high-voltage transfer switches into the configuration that is currently selected by the Source Preference Switch S4. This may result in an unintended transfer. Make sure the desired state of the high-voltage transfer switches match the setting of S4 before returning S5 to the "Normal" position.

6. When the timer runs out, the latch relay (R1) will transfer back to its original operating position.
7. Return the CONTROL MODE switch (S5) to NORMAL to return the control to service.

No Preference Operation

1. Set CONTROL MODE switch S5 to the TEST position. This will remove the control from service and allow operation without operating the high-voltage transfer switches.
2. Check the setting of the SOURCE PREFERENCE switch (S4). It should be in the center No Preference position.
3. Check LATCH RELAY STATUS TEST terminals (T-1, T-2) to ground (T-3). 120 Vac at T-1 indicates the control is in the Source I mode. 120 Vac at T-2 indicates the control is in the Source II mode.
4. Remove source voltage by unscrewing one of the phase fuses from Source I if T-1 is energized or from Source II if T-2 is energized. If a Source I fuse is removed, the PREFERRED TO ALTERNATE TIMER will start. If a Source II fuse is removed, the ALTERNATE TO PREFERRED TIMER will start.
5. When the timer runs out, the latch relay (R1) will transfer as indicated by a transfer of the 120 Vac signal at the test terminals.
6. Replace the removed fuse to re-energize the power source. No timers will start and latch relay (R1) will not transfer.
7. Unscrew one of the phase fuses from the other source. If a Source II fuse is removed, the ALTERNATE TO PREFERRED TIMER will start. If a Source I phase fuse is removed, the PREFERRED TO ALTERNATE TIMER will start.
8. When the timer runs out, the latch relay (R1) will transfer back to its original operating position, again indicated by a transfer of the 120 Vac signal at the test terminals.
9. Replace the removed fuse to re-energize the power source. No timers will start and latch relay (R1) will not transfer.
10. Place the CONTROL MODE switch (S5) to the normal position. If switch S5 is left in the TEST position, the S control will be inoperative on automatic operation.

Indicating Lamps

Although not essential to control operation, the indicating lamps provide useful operating information. All lamps are 120 Vac operated half-wave through diodes.

For a quick check of the lamp diodes, depress the LAMP TEST switch, S6. The two OPEN and two CLOSE lamps should glow with equal brilliance, the green appearing slightly less intense, and the SOURCE I ENERGIZED and SOURCE II ENERGIZED lamps should noticeably increase in brilliance (these lamps are energized from two phases, 120 degrees apart, instead of a single bus).

Note: The OPEN lamp circuit includes the impedance of the close coil or motor of the high-voltage switch actuator.

Verification of Fuses

Fuses can be checked on the front panel of the control. If the fuses are blown and require replacement, the white buttons on the front panel will show. Refer to item 15 in Figure 13 and Table 4.

Advanced Troubleshooting

IMPORTANT: The control should be removed from service prior to conducting the advanced troubleshooting procedures.

Use the output of the control procedure to determine if the problem lies in the control or the high-voltage switches. If the conditions of the output procedure are satisfactory, test the high-voltage switch. If the conditions of the output procedure are unsatisfactory, test the manual control functions. If the conditions of the manual control functions procedure are satisfactory, test the automatic control functions.

TABLE 5
Continuity Check of High-Voltage Switches

Switch Receptacle Pin	Ohmmeter Reading	
	Switch Open	Switch Closed
Type VR, VLR, VRV — Standard Operator		
B to C	Motor	∞
B to D	∞	Trip Coil
B to E	∞	0
D to F	0	0
Type VR, VLR, VRV — Quick Close Operator		
A to D	*	∞
B to C	Quick Close Coil	∞
B to D	∞	Trip Coil
B to E	∞	0
D to F	0	0
Type TSC		
B to C	Motor	∞
B to F	∞	Motor
B to E	∞	0
D to F	0	∞
Type PST-6 with C Interrupter #1		
E to R	Close Coil	∞
M to N	∞	0
P to E	*	∞
S to V	0	∞
T to U	∞	Trip Coil
Type PST-6 with C Interrupter #2		
B to C	∞	0
D to E	*	∞
E to F	Close Coil	∞
G to K	0	∞
H to J	∞	Trip Coil
Type PST-9 with C Interrupter #1		
E to F	∞	∞
A to C	∞	∞
C to E	∞	∞
B to C	∞	∞
C to D	∞	∞
Type PST-9 with C Interrupter #2		
L to M	∞	0
G to J	0	∞
J to L	∞	Trip Coil
H to J	*	∞
J to K	Close Coil	∞

* Will read motor resistance if closing spring is not charged, will read infinity if closing spring is charged.

Output of the Control

To determine if the problem is in the control or the high-voltage transfer switch, proceed as follows:

1. Disconnect the switches from the control.
2. Place OPERATION SELECTOR switch (S3) to MANUAL.
3. Place SOURCE PREFERENCE and RETURN MODE switch (S4) to NO PREF.
4. With the control energized, check the voltage to ground at the "Transfer Switch Operators" terminal board, TB1, per Table 6.
5. If these output voltages are obtained, check the high-voltage switch. If the output voltages are not obtained, check the manual control functions.

High-Voltage Switch

Normal control output at TB1 but failure to operate suggests a malfunctioning switch.

1. With an ohmmeter, check the resistance between points of the high-voltage switch actuator per Table 5.
2. If the control circuit of the switch operator checks out, the trouble may be mechanical. Refer to the maintenance manual for the switch.



Manual Control Functions

Abnormal output readings at TB1 indicate a malfunctioning control. This procedure describes the terminal functions under manual direction and suggests areas for investigation.

1. Terminals 11 and 21 provide the power to charge the springs in the switch actuator and are constantly energized. If terminals 11 and 21 are not energized, the transfer bus is not energized.
 - A. Make sure that either phase B of the preferred source or phase Y of the alternate source is energized. These phases supply the transfer bus. Measure beyond the fuses.
 - B. Relays R7 and R11 control power to the transfer bus. Relay R7 picks up when phase Y is energized; Relay R11 picks up if phase B is energized and phase Y is deenergized.
2. Terminals 15 and 25 provide 120 Vac closing power (15 closes Source I switch, and 25 closes Source II switch). Terminals 13 and 23 provide 120 Vac opening power (13 opens Source I switch and 23 opens Source II switch).
 - A. Terminals 13, 23, 15 and 25 are energized from the transfer bus through the MANUAL OPER. switches, S1 and S2.
 - (1) If the control is equipped with the fault block accessory, normally closed contacts of the fault block relay (RY1) are connected between tabs FP and FR of the relay tie board to complete the circuit to terminal 15 and between tabs FS and FT to complete the circuit to terminal 25.
 - (2) If the control does not use the fault block accessory, jumpers are provided between tabs FP and FR and FS and FT of the relay tie board to complete the closing power circuits to the transfer switches.
3. Terminals 14 and 24 are grounded by an “a” contact (N.O.) in the H.V. transfer switches to energize relays R4 and R5 respectively during the “opening” half of a parallel return transfer.
4. Terminals 16 and 26 are energized (120 Vac) on the “closing” half of a non-parallel return transfer. They are energized from a “b” contact (N.C.) in the H.V. transfer switches; 16 is energized from Source I high-voltage switch and 26 is energized from Source II high-voltage switch.

Automatic Control Functions

The control may operate properly by manual direction but malfunction in its automatic mode. The automatic section responds to the positions of R2 and R6 in conjunction with the selected operating mode as set on S4, the SOURCE PREFERENCE and RETURN MODE switch. Its output is the single-coil latching relay, R1.

1. R2 is energized from phase A of Source I through N.O. contacts of R9 in phase B and R10 in phase C. The action of R2 can be observed through its transparent cover and can be checked electrically across tabs 31 and 32 on the relay tie board which connect to a N.C. contact of the relay.
2. R6 is similarly energized from phase X of Source II through R7 in phase Y, and R8 in phase Z. Tabs 41 and 42 connect to a N.C. contact of R6.
3. Operation of the appropriate time delay relay can be checked by verifying that the LED timer is illuminated.
4. The single-coil latching relay (R1) is electrically operated and magnetically held. It is latched directly from the 120 Vac transfer bus through diode DL in the automatic mode or diode DL1 in the manual mode. It is reset through the 15 K ohm resistor and either diodes DR or DR1.
5. With the control in an automatic mode of operation, the position of the latching relay can be determined at the Latching Relay Test jacks (T1, T2, T3) on the front panel of the control.
 - A. When 120 Vac is present between T1 and T3, the relay is in the “latched” position and the control seeks to connect the load to Source I.
 - B. When 120 Vac is present between T2 and T3, the relay is in the “reset” position and the control seeks to connect the load to Source II.
 - C. If the latching relay assumes the expected position after the proper time delay, the automatic section of the control is functioning properly.

TABLE 6
Voltage Readings on TB1

Term on TB1	Voltage to Ground				
	Quiescent	MANUAL OPER. SOURCE I Switch (S1)		MANUAL OPER. SOURCE II Switch (S2)	
		Close	Open	Close	Open
11	120 Vac	120 Vac	120 Vac	120 Vac	120 Vac
15	170 Vdc*	120 Vac	170 Vdc*	170 Vdc*	170 Vdc*
14	170 Vdc*	170 Vdc*	170 Vdc*	170 Vdc*	170 Vdc*
13	0	0	120 Vac	0	0
16	0	0	0	0	0
26	0	0	0	0	0
23	0	0	0	0	120 Vac
24	170 Vdc*	170 Vdc*	170 Vdc*	170 Vdc*	170 Vdc*
25	170 Vdc*	170 Vdc*	170 Vdc*	120 Vac	170 Vdc*
21	120 Vac	120 Vac	120 Vac	120 Vac	120 Vac

* Rectified 120 Vac impressed on capacitor. Drops to 0 if LAMP TEST switch (S6) is depressed.

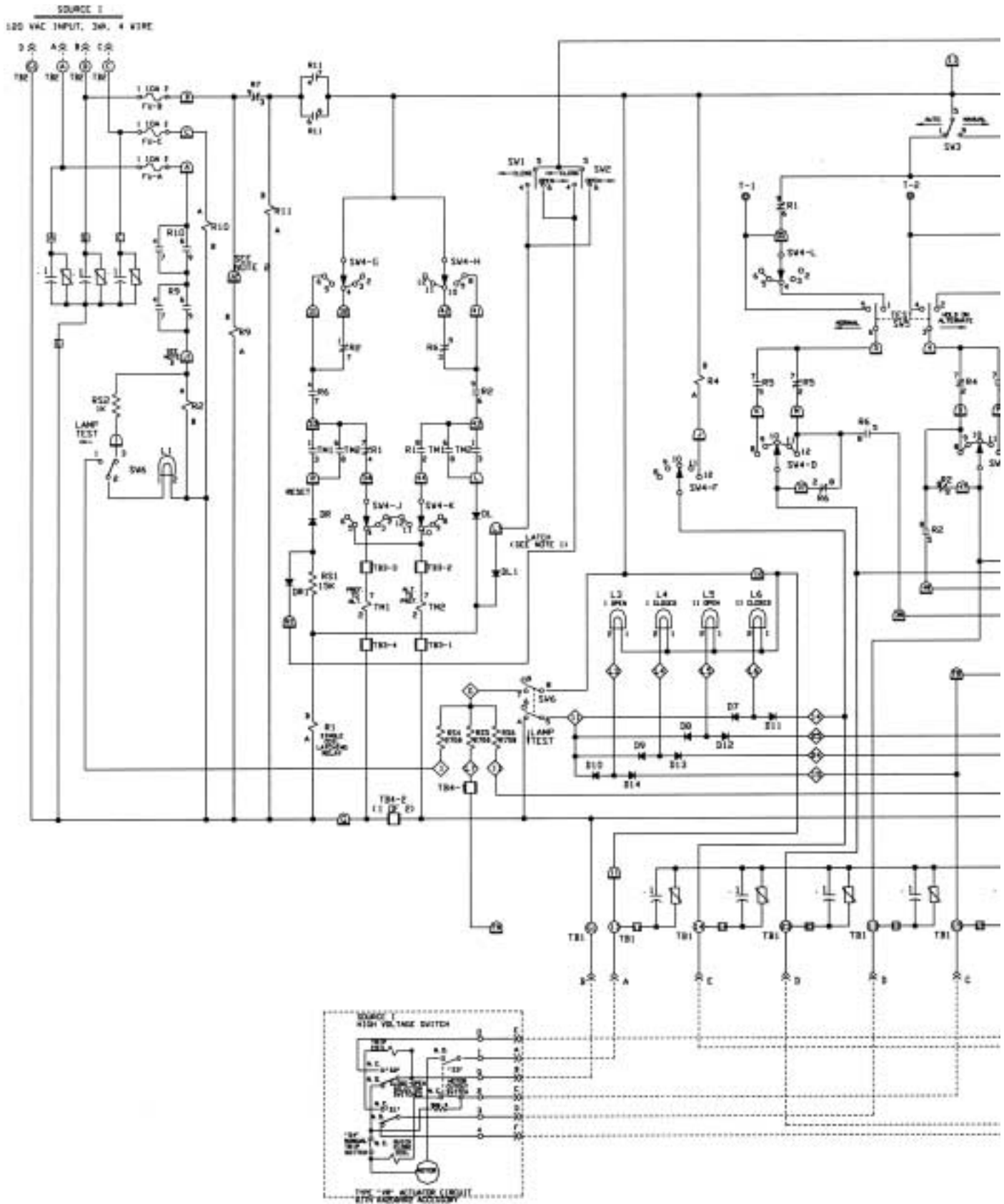

Figure 16a. Schematic diagram basic S control operating Types VR, VLR, VRV, TSC, or PST-9 switchgear (page 1 of 2).

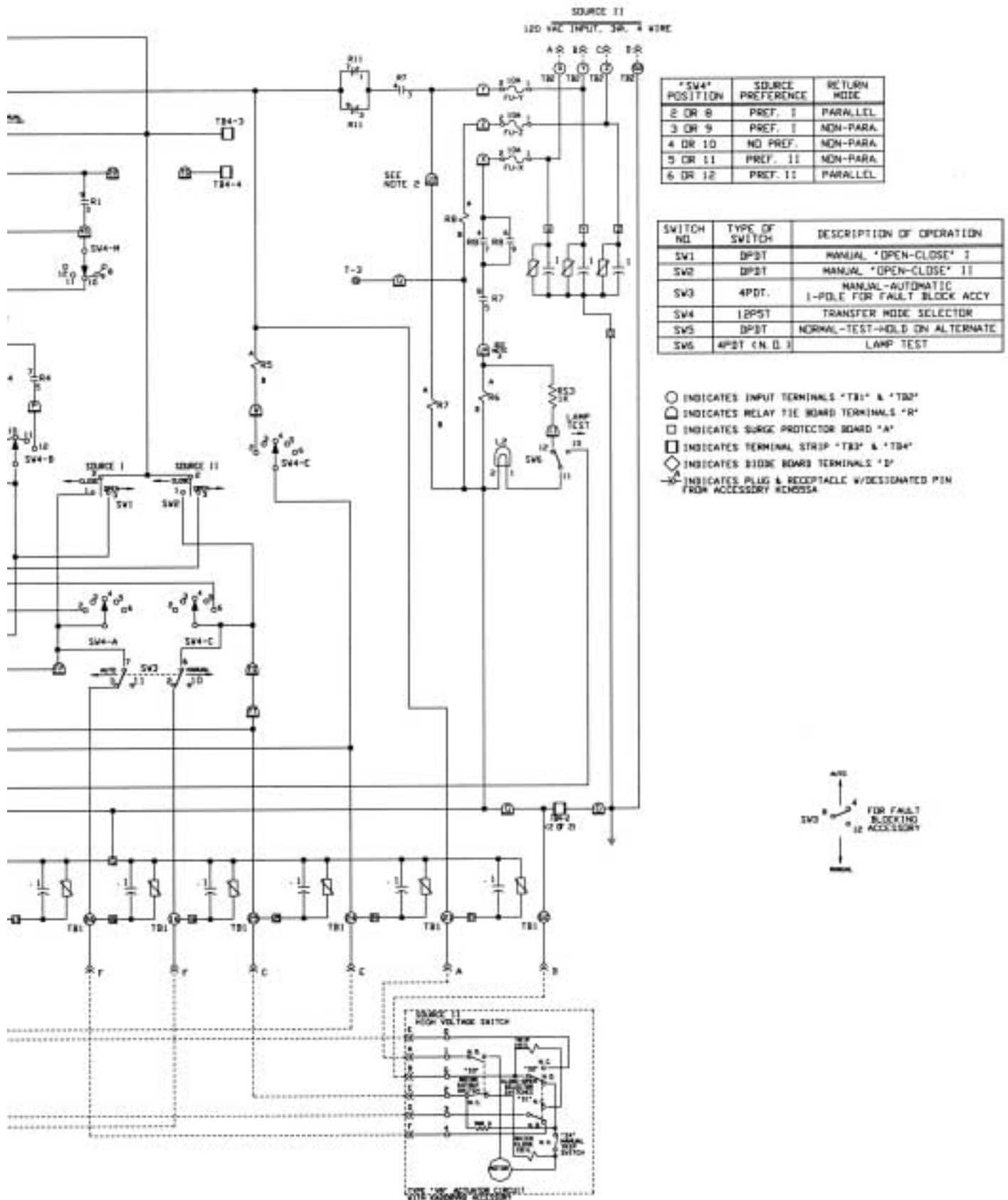

Figure 16b. Schematic diagram basic S control operating Types VR, VLR, VRV, TSC, or PST-9 switchgear (page 2 of 2).

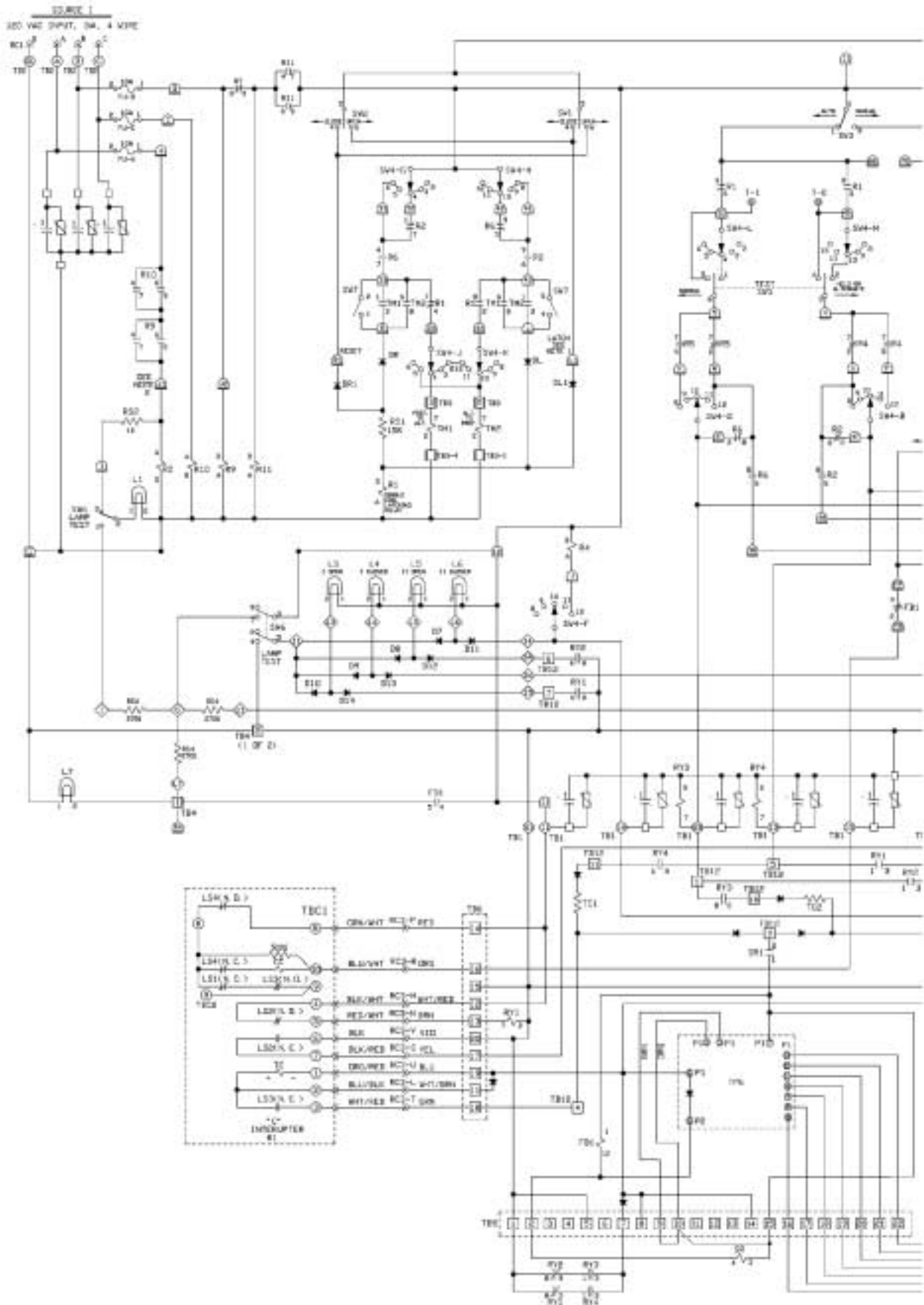

Figure 17a. Schematic diagram for Type S control operating Type PST-6 switchgear (page 1 of 2).

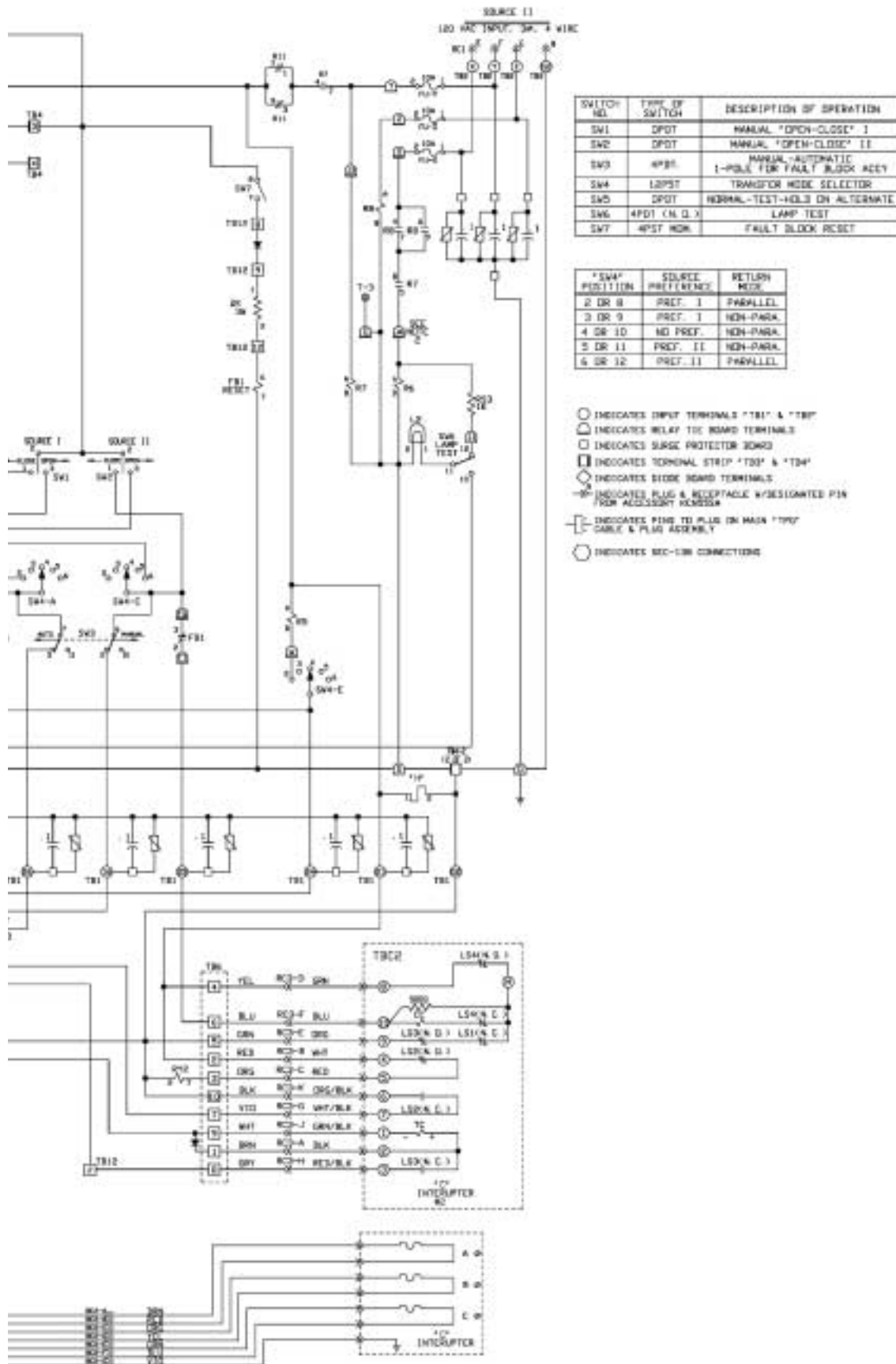

Figure 17a. Schematic diagram for Type S control operating Type PST-6 switchgear (page 2 of 2).

FAULT BLOCK ACCESSORY

(Applicable to VR, VLR, VRV, TSC, CS, and PST-6 switchgear.)

The fault block accessory is mounted in the upper right corner of the back panel of the control, Figure 18. Controls and instructions for operating the accessory are located on the front panel above the input fuses, Figure 19.

General Description

In response to fault current above preselected phase or ground levels, the accessory is activated and latched to disable both high-voltage switches. Thus a load-side fault followed by loss of potential will result in partial load transfer opening the connected source but not closing the faulted load into the alternate feeder.

The accessory must be manually reset at the control panel to restore service to the load. If activation of the fault block accessory is due to a temporary fault (preferred source voltage is restored before the transfer delay timer runs out), line current of 5 Amps, or more, flowing through the high-voltage switch will automatically reset the accessory in approximately 10 to 15 seconds.

To prevent the fault block accessory from being activated due to inrush current that may occur as a result of the backup opening and closing, an inrush restraint feature is built into the accessory logic. Upon loss of the preferred source voltage, the inrush restraint operates to increase the phase fault actuating level by a predetermined multiple for a predetermined time after voltage is restored. Simultaneously, ground fault current detection is blocked completely for the same time interval. When the time runs out, both the phase and ground current actuating levels return to their normal values.

To operate the fault block accessory, the Source I and Source II high-voltage switches must be equipped with 1000:1 ratio current transformers to monitor the magnitude of the line current and an auxiliary "a" contact. The bushing current transformers and associated wiring are provided as a factory-installed accessory to the high-voltage switch.

Accessory Settings

The selected phase and ground fault actuating levels should be greater than any peak load phase current or zero-sequence (ground) current, but less than the trip setting of the backup protective device. A general recommendation is to set the phase and ground actuating levels to approximately 80% of the phase and ground trip levels of the backup.

The phase fault current minimum actuating level is determined by a plug-in circuit card, Figure 20. Cards are available for 80, 112, 160, 224, 320 and 448 Amp actuating levels. The ground fault current minimum actuating level is determined by a resistor cartridge that clips on to the phase card. Cartridges are available for 10, 14, 20, 28, 40, 56, 80, 112, 160, 224, 320 and 448 Amp actuating levels.

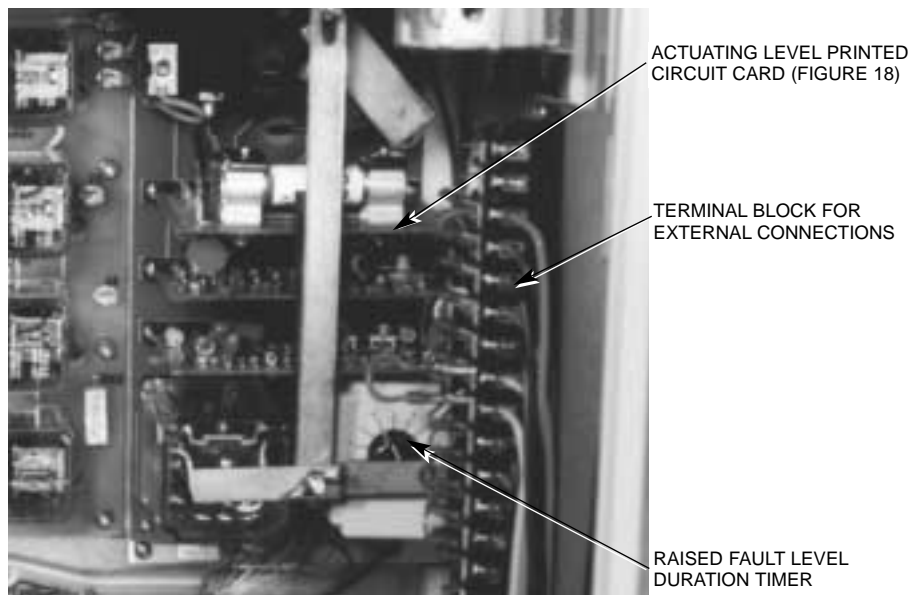

020080KM

Figure 18.
Fault block accessory mounted in upper-right corner of the back panel.



020077KM

Figure 19.
Fault block accessory controls and operating instructions plate.

The actuating level multiplier for the inrush restraint feature for phase faults is set by a jumper wire connected to a tab on the circuit card. Tabs are provided for X1, X2, X4, X6, X8 and BLOCK settings. The duration of the raised level is set by a knob on the top of the timer (Figure 18). The timer is infinitely adjustable 0.1 to 5.0 seconds. No settings are required for ground inrush since it is automatically blocked for the duration the phase level is raised.

Operating Instructions

The FAULT BLOCK OPERATED lamp on the front panel of the control, Figure 19, will light when the fault block accessory is activated. To reset the accessory:

1. Move the OPERATION SELECTOR switch (S3) to MANUAL.
2. Depress and hold the RESET switch (S7) until the lamp goes out, (approximately 6-10 seconds) indicating the accessory has reset.
3. To restore service, return the OPERATION SELECTOR switch (S3) to AUTOMATIC; the preferred source high voltage switch will close.

OR

Operate either the MANUAL OPER. SOURCE I switch (S1) or the MANUAL OPER. SOURCE II Switch (S2), as applicable, to restore service manually.

Note: Instructions for operating the fault block accessory also are printed on the front panel of the control (Figure 19).

Theory of Operation —Fault Block Accessory

The fault block accessory prevents automatic closure into the alternate source when loss of preferred source results from a fault on the load tap. The schematic diagram for the fault block accessory, Figure 21, is used as reference throughout this discussion.

Overcurrent Sensing

The output of bushing current transformers in both the Source I and Source II high voltage switches are applied to the fault block accessory via terminals IA, IB, IC, IN and IX, IY, IZ, IN respectively. When the load current through the switch exceeds the phase or ground actuating level selected, the relay contacts in the fault block accessory (contacts 7-8 and 10-11 of relay RY1-B), located in the closing circuits of both high voltage switches, are opened. Subsequent closing of either switch is blocked in either the automatic or manual mode of the S control until the fault block accessory circuitry is reset.

Phase Fault Operation

Referring to the accessory schematic diagram, Figure 21, the phase currents are rectified by the diode bridges D103 through D116. Current out of the positive side of the bridge passes through diode D127 and divides into two parallel circuits. One circuit consists of zener D123 and the minimum phase actuating resistor R301 to the other side of the bridge. The other circuit consists of normally closed contact (1516) of latching relay RY1, diode D201, and capacitor C201 to the other side of the bridge. C201, charged by load or fault current, provides tripping energy for RY1.

The current through R301 produces a voltage drop proportional to the line current which is impressed across the series resistor string R101, R102, and R103. A portion of this voltage is applied through diode D120 to the base of transistor Q201.

When this voltage exceeds the break-down voltage of zener D212 and the base emitter junctions of Q201 and Q202, Q201 will conduct causing Q204 to conduct. In turn, Q204 provides the gating current to turn on the SCR (Q206) to discharge capacitor C201 through the trip coil of the latching relay RY1. Contacts 10-11 and 7-8 of RY1 (in series with the close coils of the high voltage switches) open to prevent the high voltage switches from closing until the fault block circuitry is reset.

An important feature of this accessory is that a trip signal cannot be initiated until there is sufficient charge on C201 to activate the trip coil of RY1. Transistors Q201 and Q204, effectively in series across C201, cannot conduct until the voltage across C201 is sufficient to break-down zener diodes D211 and D212.

PHASE CURRENT LEVEL MULTIPLIER SETTING FOR INRUSH CURRENT RESTRAINT.

GROUND-ACTUATING CURRENT RESISTOR CLIPS TO THE PHASE CARD

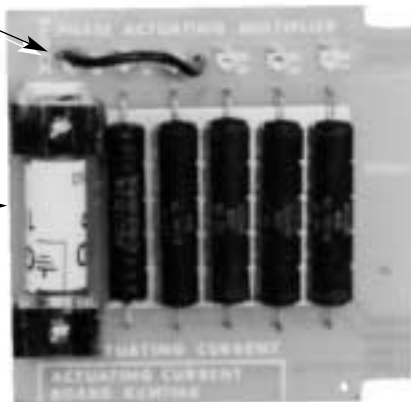

Figure 20. Phase fault current actuating level printed circuit card.

020078KM

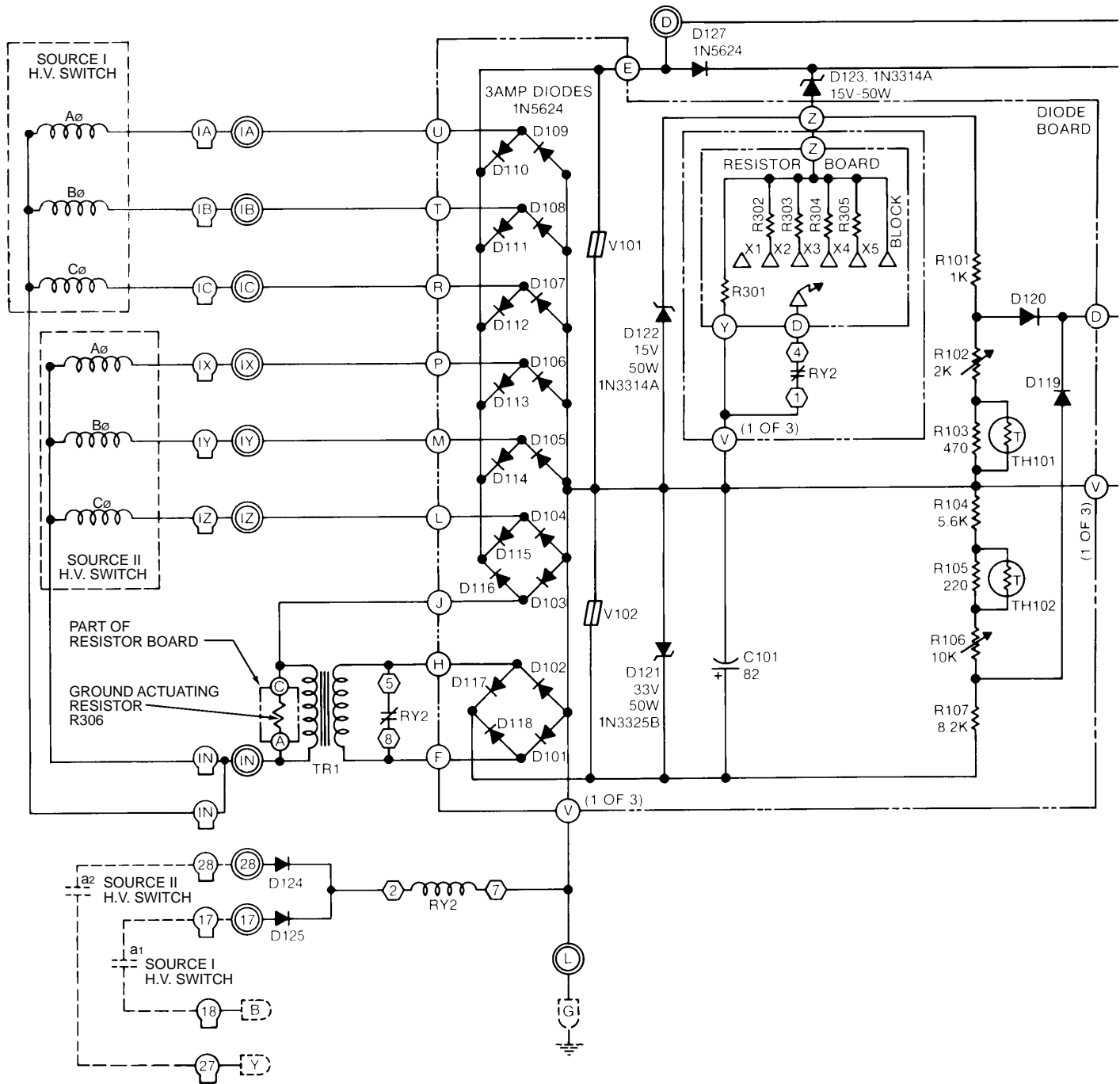

Figure 21a. Schematic diagram – fault block accessory (page 1 of 2).

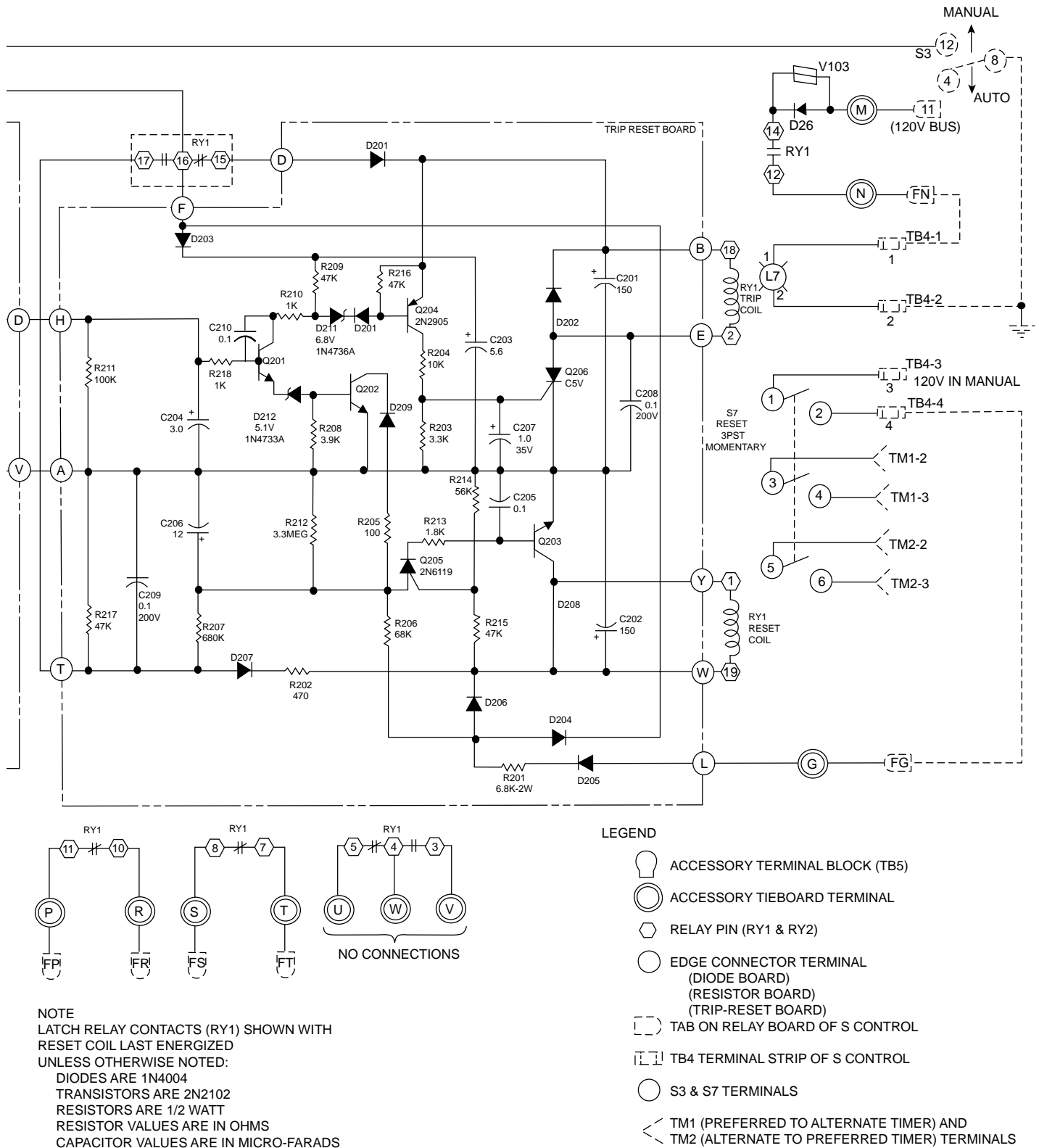

Figure 21b. Schematic diagram – fault block accessory (page 2 of 2).

Ground Fault Operation

The ground current (the vector sum of the phase currents) flows through the ground actuating resistor, R306, to produce a voltage across the primary of input transformer TR1, proportional to the ground current. This voltage is stepped-up, rectified, and impressed across the series resistor string R104, R105, R106 and R107. A portion of this voltage is applied to the base of Q201 through diode D119. From this point, ground and phase operations use common circuitry described in the preceding "Phase Fault operation" discussion.

Reset Circuits

Once actuated, the fault block accessory can be reset in either of two ways.

- Manually—Actuating the Reset Switch, S7, on the front panel of the S control, will apply 120 Vac to terminal G of the fault block accessory tie board. This voltage is rectified by diode D205 and applied to the reset timing circuit, which consists of R201, C206, and the programmable uni-junction (PUT) Q205. This voltage is also applied to capacitor C202, which provides energy to the reset coil of latching relay RY1. When the voltage across C206 reaches the breakdown voltage of the PUT, transistor Q203 is then turned on causing C202 to discharge through the reset coil of RY1. The relay transfers and the fault block accessory is now reset.

Note: S7 is energized only when the Operation Selector switch is in MANUAL.

- Automatically—by load current below the minimum actuating level flowing through the high-voltage switch. The voltage developed by the load current is applied through contact 16-17 of RY1 to the reset timing circuit R207, C206, and Q205. When the voltage across C206 reaches the breakdown voltage of the PUT, Q203 is then turned on causing C202 to discharge through the reset coil of RY1. The latching relay transfers and the fault block accessory is reset.

Note: If the load current is above the actuating level of the accessory, both manual and automatic reset is defeated by Q202 which conducts to short-out the reset timing capacitor C206 through resistor R205.

Inrush Restraint Feature

The inrush restraint feature raises the actuating level of the fault block accessory by a multiple (or blocks its operation entirely) for a period following restoration of source voltage or an automatic open transition transfer operation, to prevent inrush currents from activating the fault block.

Relay RY2 is normally energized by the phase B or phase Y voltages from the S control via the "a" auxiliary contacts in the two high-voltage switches. When both B and Y phase voltages are lost due to operation of a backup device or opening of the high-voltage switches, the coil of RY2 is de-energized, closing its contacts. Contact 1-4 closes to insert a paralleling resistor across the phase actuating resistor R301, reducing its effective value and increasing the line current necessary to actuate Q201. Contact 5-8 of RY2 closes to short-out the secondary of TR1, rendering the ground section operative.

Upon re-energization of either Phase B or Phase Y through closing of the backup devices or the closing of the high-voltage transfer switches, relay RY2 is energized. RY2 has a built-in time delay programmable by means of a knob in the top of the relay case. After the selected time delay has elapsed, N.C. contacts 1-4 and 5-6 open, returning the fault block accessory to normal operation.

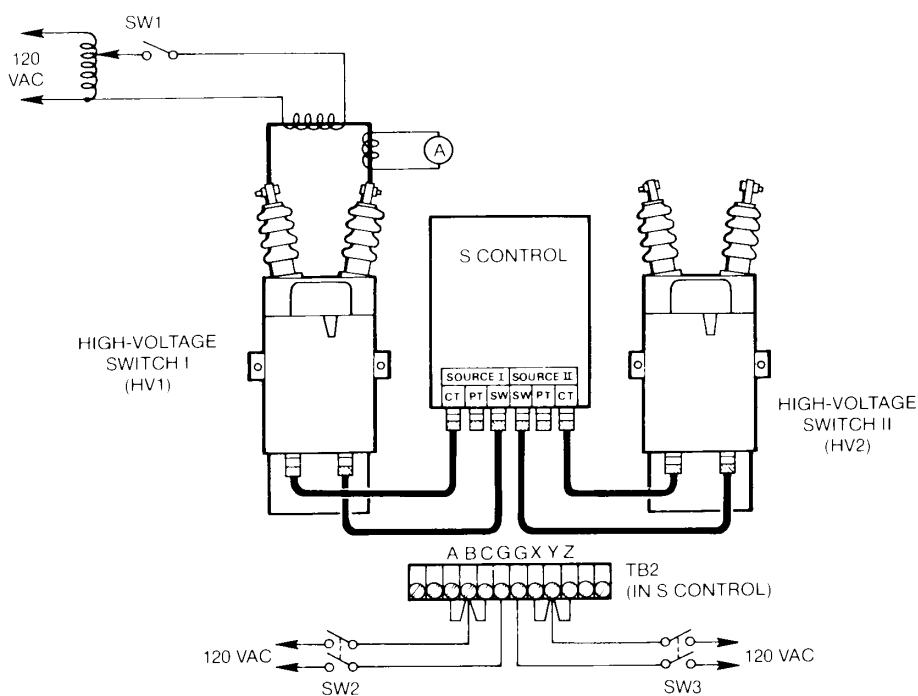

Figure 22.
Test circuit for testing and troubleshooting the fault block accessory.

Testing Fault Block Operation

WARNING: Hazardous voltage caused by backfeeding transformers. Isolate potential transformers from source bushings using potential transformer dead-break disconnect switches located on the source-side panel. Failure to do so will result in risk of possible contact with high voltage at the source bushings, which may cause death or severe personal injury.

T273.0

The operation of the fault block accessory can be checked by backfeeding a 500:5 (or other available ratio) current transformer, located in the primary loop of one phase of the preferred source high-voltage switch, from a variable 120 Vac source. The 500:5 ratio provides approximately 1 Amp of output test current for every 10 mA of input current. However, to eliminate error due to CT saturation, a separate metering CT and meter should be used to read the actual test current.

Test Circuit and Equipment

A suggested test setup is shown in Figure 22. If the control is equipped with the plug and receptacle accessory, use the existing cables to interconnect the motor operators of both high-voltage switches and the CT sensing circuits of the preferred source switch to the S control. If plugs and receptacles are not provided, wire the switches directly to the appropriate terminal blocks as shown in Figures 6 or 8.



020082KM

Figure 23.
Disabling ground sensing circuit.

Test Procedure and Troubleshooting

Phase Minimum Actuating Current

IMPORTANT: When checking the phase minimum actuating current the ground fault sensing portion of the accessory must be disabled. Testing on an individual phase basis without disabling ground fault sensing will cause the accessory to activate at the ground fault level.

1. Disable the ground sensing circuit by shorting the ground fault resistor (Figure 22).
2. Set the inrush current multiplier at X1.
3. Close test circuit switches SW2 and SW3 to apply voltage to the control.

The preferred source high-voltage switch (HV1) will close.

4. Close test switch SW1 and slowly raise the test current until the FAULT BLOCK OPERATED light goes on.

The test current should be within the limits specified in Table 7. If FAULT BLOCK OPERATED light fails to come on at the expected level, proceed as follows:

- A. Check lamp with LAMP TEST switch (S6).
- B. Recheck calculations for proper meter reading.
- C. Is ground resistor cleanly shorted out?
- D. Did latch relay R1 transfer position?—lamp is only an outward indication of relay position.
- E. Are all cable connections secure?
- F. Voltage from Accessory Tie Board, Tab D to Ground, Tab L, should be approximately 15 Vdc, average, at actuating level. If observed voltage is approximately 6 volts too low, trouble is probably in the Trip Reset Board; if voltage is too high, trouble is probably in either Diode or Resistor Boards.
- G. AC rms voltage from “IN” to “IA” (or whatever phase is energized) should be about 17 V at actuating level. If correct voltage is observed, the CT input is correct.

TABLE 7
Test Current Values for Fault Block Accessory

Actuating Current Setting (Amps)	Actuating Current Limits (Amps)	
	Minimum	Maximum
10	9	11
14	12.6	15.4
20	18	22
28	25.2	50.8
40	36	44
56	50.4	61.6
80	72	88
112	101	123
160	144	176
274	247	301
320	250	352
448	403	493

5. Open SW1 and SW2 to simulate a backup clearing the fault.

The PREFERRED TO ALTERNATE TIMER will start and the preferred source high-voltage switch (HV1) will open when the timer runs out, but the alternate source high-voltage switch (HV2) will not close.

If alternate source switch (HV2) closes and the latch relay (R1) contacts are not opening, check for open contact between Accessory Tie Board tabs P and R (Source I HV switch) and tabs S and T (Source II HV switch).

6. Place OPERATION SELECTOR SWITCH (S3) to manual, and operate MANUAL OPER SOURCE I switch (S1) and MANUAL OPER SOURCE II switch (S2) to CLOSE.

HV switch (HV1 or HV2) will not close.

If either switch closes and the latch relay (R1) contacts are not opening, check for open contact between Accessory Tie Board tabs P and R (Source I HV switch) and tabs S and T (Source II HV switch).

7. Close test switch SW2 to restore preferred source voltage to the control. After the ALTERNATE TO PREFERRED TIMER runs out, reset the fault block accessory per instructions on the front panel.

The FAULT BLOCK OPERATED light will go out and the preferred source high-voltage switch will close.

If the FAULT BLOCK OPERATED light does not go out, the problem is most likely in the TRIP RESET BOARD.

Follow steps 8 through 11 to conduct a complete check involving all the phases of both high-voltage switches.

8. Connect the phases in series as shown in Figure 24 and retest.

Because of the series hook-up, pickup should occur at 1/2 the actuating current setting.

If pickup current is other than 1/2 of setting, the polarity of a CT could be reversed.

9. Connect another two phases in series as shown in Figure 25 and retest.

Results should be the same as in preceding step 8.

10. Repeat step 8 and 9 for the other high-voltage switch to complete checking all six CTs, their connections and polarity.

11. Remove the shorting jumper from the ground fault resistor upon completion of phase testing.

Ground Minimum Actuating Current

When checking the ground minimum actuating current, the phase fault sensing portion of the accessory circuit must be disabled to prevent the possibility of erroneous test results. Proceed as follows:

1. Disable the phase sensing circuit by placing a shorting jumper from the BLOCK tab on the phase resistor card to tab L on the accessory tie-board (Figure 26).
2. Repeat steps 2 through 7 of the Phase Minimum Actuating Current test procedure.

Automatic Reset of Fault Block

1. Close test switches SW2 and SW3 to supply voltage to the control.

The preferred source high-voltage switch (HV1) will close.

2. Close SW1 and raise the test current until the FAULT BLOCK OPERATED lamp lights indicating that fault block has been activated.

3. Open SW2 to simulate the back-up device opening and simultaneously open SW1 to clear the fault.

The PREFERRED TO ALTERNATE TIMER will start to run.

4. Close SW2 to simulate reclosing of Source 1 back-up device. Quickly close SW1 and raise the test current to greater than 5 Amps but less than ground actuating level.

The FAULT BLOCK OPERATED lamp will go out in about 10-15 seconds indicating the accessory has reset.

If FAULT BLOCK OPERATED lamp does not go out, the trouble is most likely in the Trip-Reset board (assuming the previous tests had passed).

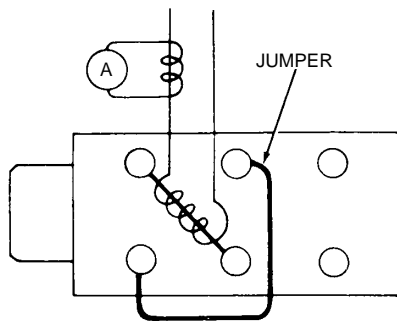

Figure 24.
Test Connections for Step 8.

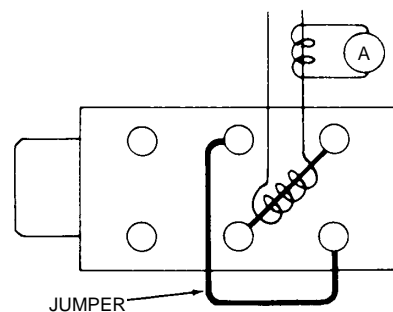

Figure 25.
Test Connections for Step 9.

Inrush Restraint

The inrush-restraint feature prevents inrush currents above the minimum actuating level from actuating the accessory. This is accomplished by raising the phase actuating level by some multiple for a predetermined time after service is restored. Ground actuating level detection is blocked for the duration of the raised phase actuating level. Proceed as follows:

1. Disable the ground sensing circuit by shorting the ground fault resistor (Figure 26).
2. Set the inrush-restraining multiplier on the phase actuating card and the raised fault-level duration on the timer to the values at which they are to be checked.
3. With the preferred source high-voltage switch (HV1) closed, close test switch SW1 and raise the equivalent test current to a value above the maximum actuating level for the setting, but below the multiplied setting. (See Table 7 for maximum current test values.)
4. Without disturbing this current setting, open SW1.
5. Close test circuit switches SW2 and SW3 to apply voltage to the control.
6. Momentarily close and open SW1 before the raised duration timer runs out, to simulate an inrush current.

The FAULT BLOCK OPERATED lamp will not light.

If the FAULT BLOCK OPERATED lamp does light, proceed as follows:

- A. Recheck current calculations. (Test current should exceed actuation level but be less than inrush level.)
 - B. Check if momentary faults were applied before timer elapsed.
 - C. Check if timing relay picked up after either HV1 or HV2 was closed. Check presence or absence of 120 Vac at Accessory Tie Board terminal 17 when HV1 operates and terminal 28 when HV2 operates.
 - D. Check for trouble in delay relay contacts or resistor board.
7. Close SW1 and leave closed to simulate a permanent fault on the load side.

The FAULT BLOCK OPERATED lamp will light after the raised duration timer runs out.

If FAULT BLOCK OPERATED lamp does not light, the problems are similar to step 6 above.

8. Open switches SW2 and SW3 to remove voltage from the accessory.
9. Raise the test current to a value just above the raised multiple value.
10. Without disturbing this current setting, open SW1.
11. Again close switches SW2 and SW3 to apply voltage to the control.
12. Close SW1 to simulate a high-level fault on the load side of the switch.

The FAULT BLOCK OPERATED lamp will light immediately indicating the fault is greater than the inrush current restraining setting.

If FAULT BLOCK OPERATED lamp does not light immediately, then

- A. Recalculate expected current.
- B. Verify that jumper on resistor board is on correct tab.

If FAULT BLOCK OPERATED lamp still does not light immediately, the resistor board may be defective. Contact your Cooper Power Systems representative.

13. Remove the shorting jumper from the ground fault actuating cartridge upon completion of the test.

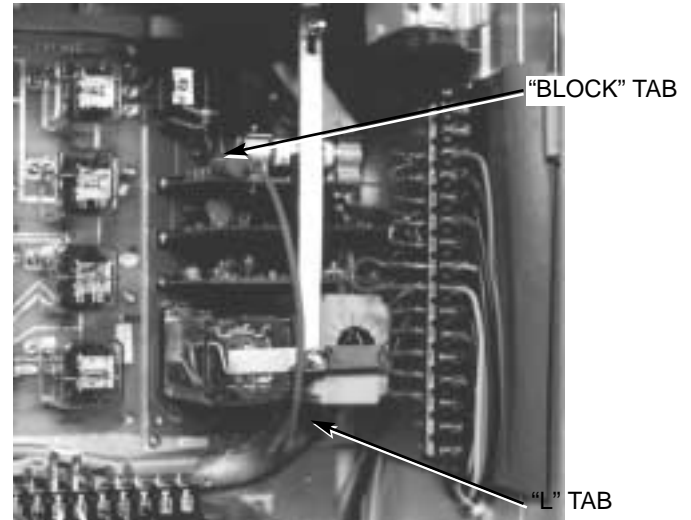

Figure 26.
Disabling phase sensing.

020083KM

Return the Control to Service

CAUTION: Equipment misoperation. Do not energize this equipment until all control settings have been properly programmed and verified. Refer to the Control Programming and Operation section of this manual for programming procedures. Failure to comply can result in misoperation (unintended operation), equipment damage, and personal injury.

G118.1

CAUTION: Equipment misoperation. Source I and Source II high voltage switches can be paralleled in the manual operation mode even if SOURCE PREFERENCE switch, S4, is set for NP (non-parallel operation). Make sure both sources are in synchronism if a manual parallel operation is to be performed. Failure to comply can result in misoperation (unintended operation) and equipment damage.

T304.0

1. The control must be programmed with all the necessary operating settings and verified by the appropriate personnel prior to operation with energized switchgear.
2. Verify status of high voltage switches according to system requirements.
3. Reconnect cables and ground the control.
4. Apply Source I and Source II voltage to the control.

WIRING TABLES

Tables 21 through 40 identify the point-to-point wiring between circuit components.

Tables 36–40 apply to S Controls with the Fault Block Accessory.

The physical location of the circuit components and their terminals identification are shown in Figure 27.

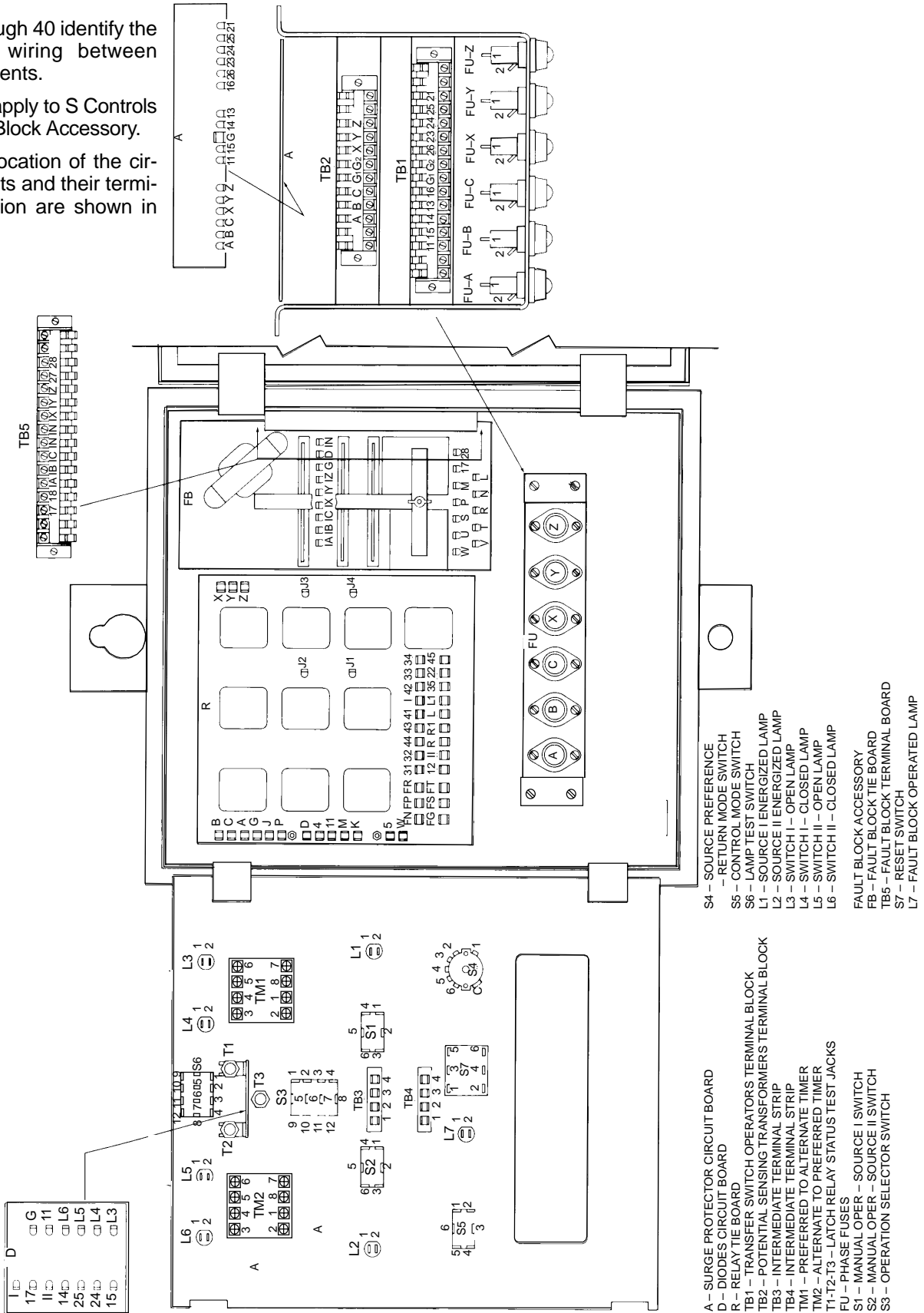

Figure 27.
Location of circuit components wiring terminal identification.

TABLE 8

“A” Surge Protector Circuit Board		
From	To	Color
A	FU-A-1	BRN
B	FU-B-1	ORG
C	FU-C-1	GRN
G	Stud on Cabinet	WHT
X	FU-X-1	VIO
Y	FU-Y-1	WHT
Z	FU-Z-1	BRN/WHT
11	TB1-11	BRN
13	TB1-13	YEL
14	TB1-14 RA(B-7)*	ORG ORG
15	TB1-15	RED
16	TB1-16	GRN
21	TB1-21	BLK
23	TB1-23	VIO
24	TB1-24 RA(A-7)*	GRY GRY
25	TB1-25	WHT
26	TB1-26	BLU

TABLE 9

“D” Diodes Circuit Board		
From	To	Color
I	S6-1	RED
II	S6-10	BRN
G	S6-7	BRN
L3	L3-2	BRN
L4	L4-2	RED
L5	L5-2	ORG
L6	L6-2	YEL
L7	TB4-1	ORG
11	S6-5	RED
14	S4(F-C)	YEL
15	TB1-15	BLU
24	S4(E-C)	GRN
25	TB1-25	GRN

TABLE 10

TB1 Output Terminal Block		
From	To	Color
G1	TB1-G2 Screw on Back Panel	WHT WHT
G2	TB1-G1 TB2-G2	WHT WHT
11	R-1 TB1-21 A-11	BLK BLK BRN
13	S1-3 A-13 R-47	BLK YEL BLK
14	S4(F-C) A-14	RED ORG
15	R-FR D-15 A-15	BLU BLU RED
16	S3-2 A-16	YEL GRN
21	TB1-11 A-21	BLK BLK
23	S2-3 A-23	WHT VIO
24	S4(E-C) A-24	BRN GRY
25	R-FT A-25 D-25	GRN WHT GRN
26	S3-3 A-26	ORG BLU

TABLE 11

TB2 Input Terminal Block		
From	To	Color
A	FU-A-1	RED
B	FU-B-1	YEL
C	FU-C-1	BLU
G1	C-2 TB2-G2	WHT WHT
G2	TB1-G2 TB2-G1	WHT WHT
X	FU-X-1	GRY
Y	FU-Y-1	BLK
Z	FU-Z-1	RED/WHT

TABLE 12

TB3 Terminal Strip		
From	To	Color
1	TM2-8 S6-4	Motor Lead YEL
2	TM2-7 S4(K-8)	Motor Lead WHT
3	TM1-7 S4(J-4)	Motor Lead GRY
4	TM1-8 S6-4	Motor Lead GRN

TABLE 13

TB4 Terminal Strip		
From	To	Color
1	D-L7 R-FN L7-1*	ORG GRN BRN
2	T3 L7-2* S3-8*	BRN RED ORG
3	S1-2 S7-1*	BRN BRN
4	R-FG S7-2*	YEL RED

* Fault Block Accessory Connections

TABLE 14

FU-A Source I – Phase A Fuse		
From	To	Color
1	A-A TB2-A	BRN RED
2	R-A	BRN

TABLE 15

FU-B Source I – Phase B Fuse		
From	To	Color
1	A-B TB2-B	ORG YEL
2	R-B	RED

TABLE 16

FU-C Source I – Phase C Fuse		
From	To	Color
1	A-C TB2-C	GRN BLU
2	R-C	ORG

TABLE 17

FU-X Source II – Phase X Fuse		
From	To	Color
1	A-X TB2-X	VIO GRY
2	R-X	YEL

TABLE 18

FU-Y Source II – Phase Y Fuse		
From	To	Color
1	A-Y TB2-Y	WHT BLK
2	R-Y	GRN

TABLE 19

FU-Z Source II – Phase Z Fuse		
From	To	Color
1	A-Z TB2-Z	BRN/WHT RED/WHT
2	R-Z	BLU

TABLE 20

TM1 PREFERRED TO ALTERNATE TIMER		
From	To	Color
1	R-33 TM2-6	ORG ORG
2	TB3-4	BLK
3	R-R TM2-8	YEL YEL
4	–	–
5	–	–
6	R-43 TM2-1 S7-8*	BRN BRN BLU
7	TB3-3	BLK
8	TB2-3 R-L S7-7*	RED RED GRN

* Fault Block Accessory Connections

TABLE 21

TM2 ALTERNATE TO PREFERRED TIMER		
From	To	Color
1	TM1-6	BRN
2	TB3-1	BLK
3	TM1-8	RED
4	–	–
5	–	–
6	TM1-1 S7-4*	ORG ORG
7	TB3-2	BLK
8	TM1-3 S7-5*	YEL YEL

* Fault Block Accessory Connections

TABLE 22

“R” Relay Tie Board		
From	To	Color
A	FU-A-2	BRN
B	FU-B-2 TB-5-18*	RED BRN
C	FU-C-2	ORG
D	S4(B-8)	ORG
G	TB2(G-1) T-3 FB-L*	WHT ORG RED
J	S4(F-12)	GRY
K	S4(D-8)	BLU
L	TM1-3	RED
L1	S1-4	BLU
M	S4(D-12)	RED
P	S4(B-12)	YEL
R	TM1-6	YEL
R1	S2-4	VIO
W	S4(E-2)	VIO
X	FU-X-2	YEL
Y	FU-Y-2 TB5-27*	GRN RED
Z	FU-Z-2	BLU
FG	TB4-4 FB-G*	YEL BRN
FN	TB4-1 FB-N*	GRN YEL
FP	S4(A-C) R-FR** FB-P*	BRN BLK GRN
FR	TB1-15 R-FP** FB-R	BLU BLK BLU
FS	S4(C-C) R-FT** FB-S*	GRN BLK VIO
FT	TB1-25 R-FS** FB-T*	GRN BLK GRY
J1 J2 J3 J4	Used with capacitor voltage sensing accessory	
I	S6-3	BRN/WHT
II	S6-12	GRY
4	S5-3	RED
5	S5-6	BRN
11	S3-5 TB1-11 FB-M*	RED BLK ORG
12	L3-1	VIO
22	S3-1	BRN
31	S4(G-6)	BLK
32	S4(G-2)	WHT
33	TM1-5	ORG
34	S4(J-C)	ORG
35	S4(L-C)	GRN
41	S4(H-8)	BRN/WHT
42	S4(H-12)	RED/WHT
43	TM1-2	BRN
44	S4(K-C)	YEL
45	S4(M-C)	BLU
47	TB1-13	BLK
48	S4(C-6)	GRY

* Fault Block Accessory Connections

** Omit jumpers if fault block included.

TABLE 23

S5 CONTROL MODE Switch		
From	To	Color
1	S4(L-6)	RED
2	S4(M-8)	GRN
3	R-4	RED
4	T-2	ORG
5	T-1	RED
6	R-5	BRN

TABLE 24

S6 LAMP TEST Switch		
From	To	Color
1	D-I	RED
2	L1-1	BRN
3	R-I	BRN/WHT
4	T-3 TB3-4 TB3-1	ORG GRN YEL
5	D-11	RED
6	–	–
7	D-G	BRN
8	SW3-5	BLU
9	–	–
10	D-II	BRN
11	L2-1	RED
12	R-II	GRY

TABLE 25

L1 SOURCE I ENERGIZED Lamp		
From	To	Color
1	S6-2	BRN
2	L2-2	ORG

TABLE 26

L2 SOURCE II ENERGIZED Lamp		
From	To	Color
1	R-II	GRY
2	L1-2 T3	ORG YEL

TABLE 27

L3 SWITCH I OPEN Lamp		
From	To	Color
1	R-12 L4-1	VIO VIO
2	D-L3	BRN

TABLE 28

L4 SWITCH I CLOSED Lamp		
From	To	Color
1	L5-1 L3-1	VIO VIO
2	D-L4	RED



TABLE 29

S4 SOURCE PREFERENCE & RETURN MODE Switch							
From	To	Color	From	To	Color		
A-C	R-FP	BRN	G-4	R-32	WHT		
	S1-1	BRN	G-5	R-31	BLK		
A-2	R-38	VIO	G-6				
A-3			H-C	S3-5	VIO		
A-4				S4(G-C)	Bare		
A-5			H-8	R-41	BRN/WHT		
A-6			H-9				
B-C	S1-3	ORG	H-10				
B-8	R-D	ORG	H-11	R-42	RED/WHT		
B-9							
B-10					J-C	R-34	ORG
B-11					J-2	S4(K-12)	Bare
B-12	R-P	YEL	J-3				
C-C	R-FS	GRN	J-4	S4(K-12)	Bare		
	S2-1	YEL		TB3-3	GRY		
C-2			J-5	S4(K-10)	Bare		
C-3			J-6				
C-4			K-C	R-44	YEL		
C-5			K-8	TB3-2	WHT		
C-6	R-48	GRY	K-9				
D-C	S2-3	BLU	K-10	S4(J-6)	Bare		
D-8	R-K	BLU	K-11	S4(J-2)	Bare		
D-9	R-M	RED	K-12				
D-10				L-C	R-35	GRN	
D-11				L-2	-	-	
D-12				L-3	-	-	
E-C	D-24	GRN	L-4				
	TB1-24	BRN	L-5	S5-1	RED		
E-2	R-W	VIO	L-6				
F-C	D-14	YEL	M-C	R-45	BLU		
	TB1-14	RED		T-2	BRN		
F-12	R-J	GRY	M-8				
G-C	S4(H-C)	Bare	M-9	S5-2	GRN		
G-2	R-32	WHT	M-10				
G-3							

TABLE 30

L5 SWITCH II OPEN Lamp		
From	To	Color
1	L6-1	VIO
	L4-1	VIO
2	D-L5	ORG

TABLE 31

L6 SWITCH II CLOSED Lamp		
From	To	Color
1	L5-1	VIO
2	D-L6	YEL

TABLE 32

S1 MANUAL OPER. SOURCE I Switch		
From	To	Color
1	S3-7	VIO
	S4(A-C)	BRN
2	S2-2	RED
	TB4-3	BRN
	S1-5	Bare
3	TB1-13	BLK
	S4(B-C)	ORG
4	R-L1	BLU
	S2-6	YEL
5	S1-2	Bare
6	S2-4	YEL

TABLE 33

T1-T2-T3 LATCH RELAY STATUS TEST Terminal		
From	To	Color
T1	S4(L-C)	RED
	S5-5	RED
T2	S4(M-C)	BRN
	S5-4	ORG
T3	L2-2	YEL
	S6-4	ORG
	TB4-2	BRN
	R-G	ORG

TABLE 34

S2 MANUAL OPER. SOURCE II Switch		
From	To	Color
1	S4(C-C) S3-6	YEL BLU
2	S1-2 S2-5 S3-9	RED Bare GRN
3	TB1-23 S4(D-C)	WHT BLU
4	R-R1 S1-6	VIO YEL
5	S2-2	Bare
6	S1-4	YEL

TABLE 35

S3 OPERATION SELECTOR SWITCH		
From	To	Color
1	R-22	BRN
2	TB1-16	YEL
3	TB1-26	ORG
4	–	–
5	R-11 S4(H-C) S6-8	RED VIO BLU
6	S2-1	BLU
7	S1-1	VIO
8	TB4-2*	ORG
9	S2-2	GRN
10	–	–
11	–	–
12	FB-D*	BLK

* Fault Block Accessory Connections

TABLE 36

“FB” Fault Block Accessory Tie Board		
From	To	Color
IA	TB5-IA	BRN
IB	TB5-IB	RED
IC	TB5-IC	ORG
IX	TB5-IX	YEL
IY	TB5-IY	GRN
IZ	TB5-IZ	BLU
G	R-FG	BRN
D	S3-12	BLK
IN	TB5-IN	VIO
W	–	–
U	–	–
S	R-FS	VIO
P	R-FP	GRN
M	R-11 RA(A-2)	ORG BLK
17	TB5-17	GRY
28	TB5-28	WHT
V	–	–
T	R-FT	GRY
R	R-FR	BLU
N	R-FN	YEL
L	R-G	RED

TABLE 37

L7 FAULT BLOCK OPERATED		
From	To	Color
1	TB4-1	BRN
2	TB4-2	RED

TABLE 38

“TB5” Fault Block Accessory Terminal Block		
From	To	Color
17	FB-17 RA(A-1)	GRY GRN
18	R-B RA(A-6)	BRN BRN
IA	FB-IA	BRN
IB	FB-IB	RED
IC	FB-IC	ORG
IN ₁	FB-IN IN ₂	VIO BLK
IN ₂	IN ₁	BLK
IX	FB-IX	YEL
IY	FB-IY	GRN
IZ	FB-IZ	BLU
27	R-Y RA(B-6)	RED RED
28	FB-28 RA(B-1)	WHT WHT

TABLE 39

S7 Fault Block RESET Switch		
From	To	Color
1	TB4-3	BRN
2	TB4-4	RED
4	TM2-6	ORG
5	TM2-8	YEL
7	TM1-8	GRN
8	TM1-6	BLU

TABLE 40

“RA” Fault Block Accessory Relay		
From	To	Color
A1	TB5-17	GRN
A2	FB-M	BLK
A6	TB5-18	BRN
A7	A-24	GRY
B1	TB5-28	WHT
B6	TB5-27	RED
B7	A-14	ORG

REPLACEMENT PARTS

Parts listed and illustrated include only those parts and assemblies usually furnished for repair. Because of the ease, faster receipt, and greater economy of local acquisition, the wiring, wire end terminations, and common hardware parts are not included in the replacement parts listing.

To assure correct receipt of any parts order, always include the control type and serial number. Because of Cooper Power Systems' continuous improvement policy, there may be instances where parts furnished may not look exactly the same as the parts ordered.

However, they will be completely interchangeable without any rework of the control. All parts carry the same warranty as the original control, i.e., against failure due to defects in material or workmanship within one year from date of shipment.

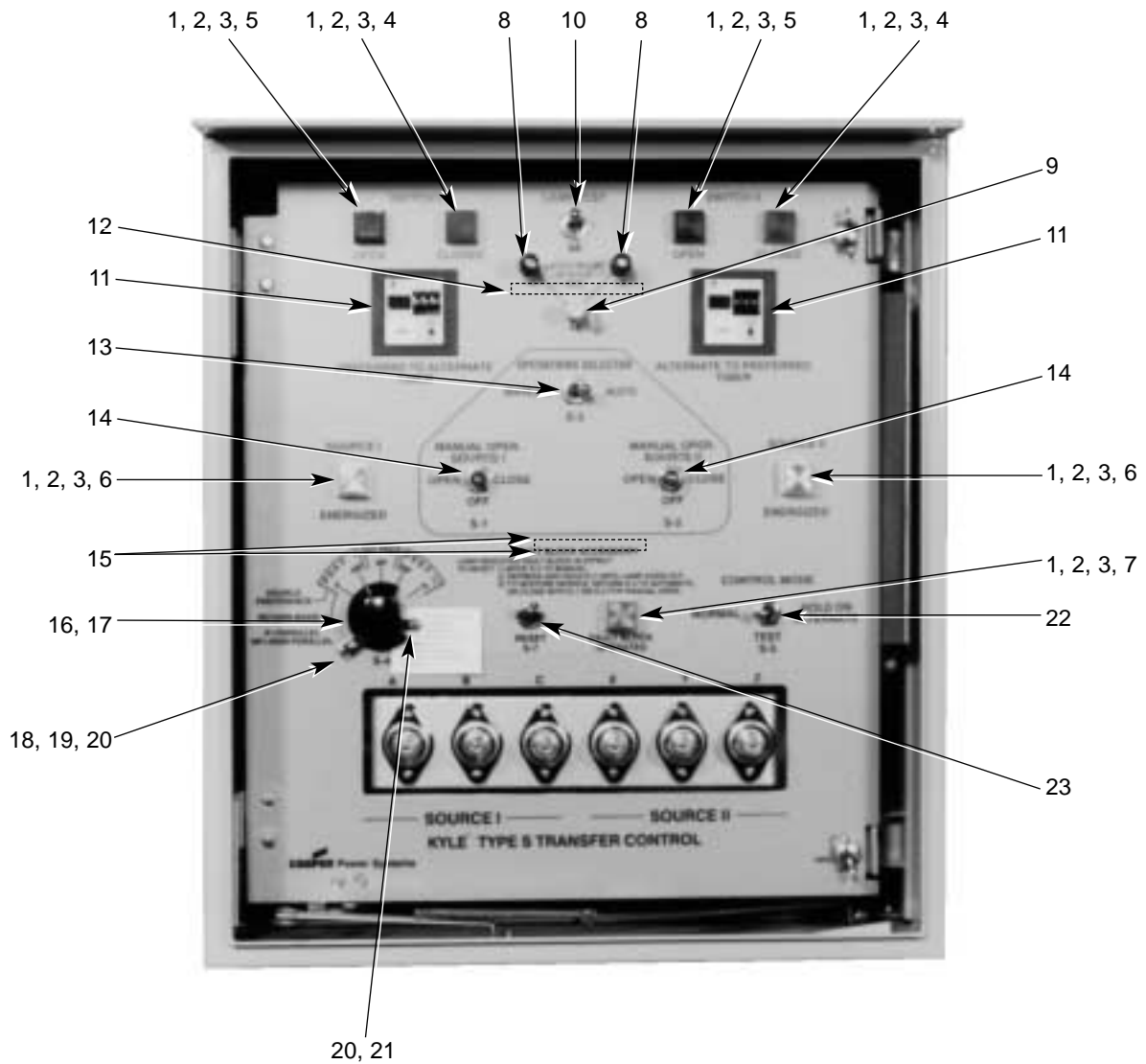

Figure 28.
Front panel – replacement parts identification.

020076KM

Front Panel Replacement Parts List

Index No.	Description	Catalog Number	Qty.
1	Lamp socket	KP2361A1	6
2	Socket fastener	KP2005A10	6
3	Lamp	KP2276A3	6
4	Lens, red (L4, L6)	KP2277A2	2
5	Lens, green (L3, L5)	KP2277A5	2
6	Lens, clear (L1, L2)	KP2277A3	2
7	Lens, amber (L7)	KP2277A4	1
8	Terminal post, black (T1, T2)	KP2081A2	2
9	Terminal post, white (T3)	KP2081A1	1
10	Toggle switch, 4PST (S6)	KP2124A26	1
11	Digital timer (TM1, TM2) 0.01 sec. to 99.9 hrs. range	KP2159A2	2

Index No.	Description	Catalog Number	Qty.
12	Diode circuit board assembly	KCN120SA	1
13	Toggle switch, 4PDT (S3)	KP2124A16	1
14	Toggle switch, DPDT (S1, S2)	KP2124A6	2
15	Intermediate terminal strip (TB3, TB4)	KP432ME	2
16	Rotary selector switch (S4)	KCN199S	1
17	Switch knob	KCN149S1	1
18	Knob lock	KP107RS	1
19	Lock backing	KP497ME	1
20	Self tapping screw, 6-32 x 1/2, stl	K751515106050A	2
21	Spacer	KP3004A59	1
22	Toggle switch, DPDT (35)	KP2124A21	1
23	Toggle switch, 3PST (S7)	KP2124A43	1

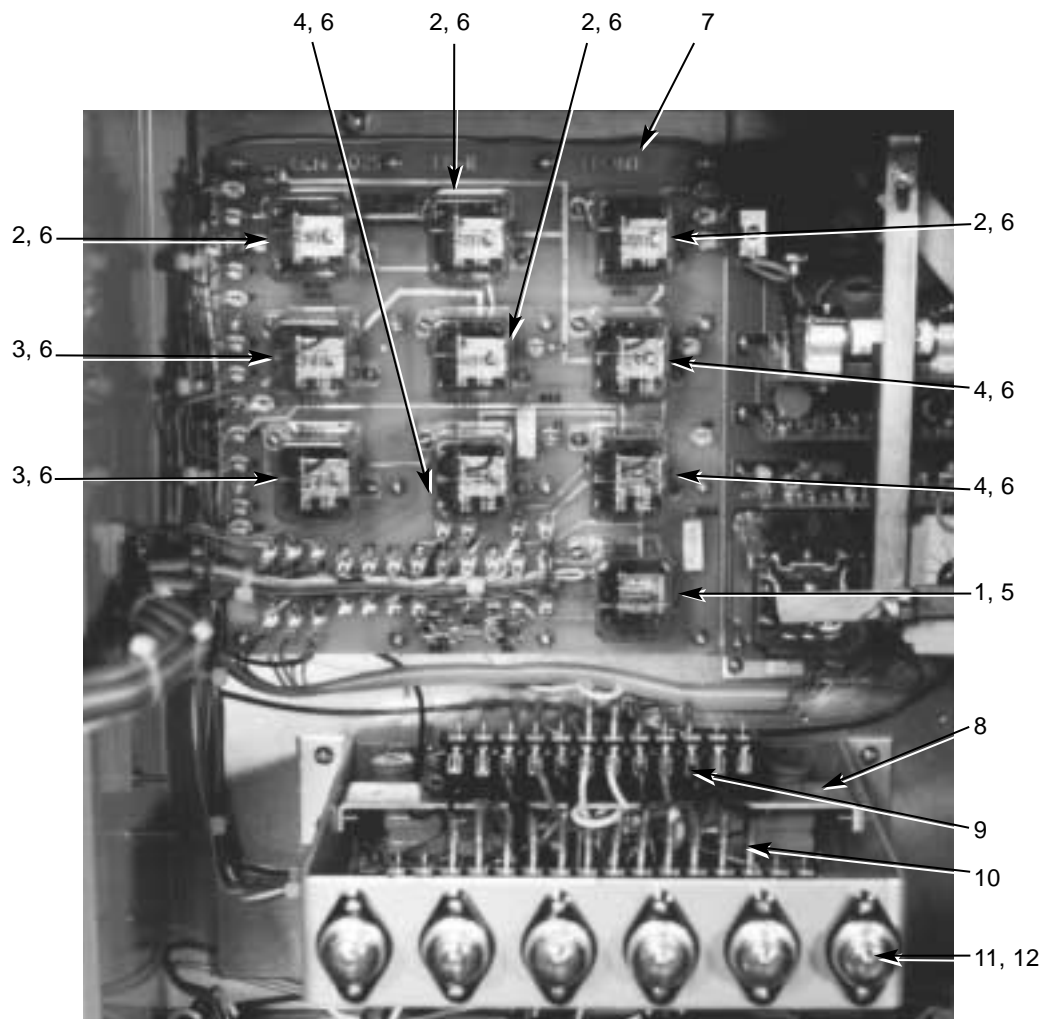

Figure 29.
Back panel – replacement parts identification.

020080KM

Back Panel Replacement Parts List

Index No.	Description	Catalog Number	Qty.
1	Relay (R1)	KP978ME	1
2	Relay (R8, R9, R10, R11)	KP978ME	6
3	Relay (R4, R5)	KP978ME	2
4	Relay (R2, R6, R7)	KP978ME	1
5	Relay retainer	K999904310339A	1
6	Relay retainer	K999904310339A	9
7	Relay tie board subassembly	KCN203S900	1
8	Surge protector board assembly	KCN125SA	1
9	Terminal block (TB2) (Consists of the following components)		
	Terminal section	KP999904150097A	12
	End piece	KP999904150064A	1
	Marker strip	KP2076A50	1
10	Terminal block (TB1) (Consists of the following components)		
	Terminal section	KP999904150097A	16
	End piece	KP999904150064A	1
	Marker strip	KP2076A50	1
11	Fuse holder	KP124S	6
12	Fuse	KP125S	6

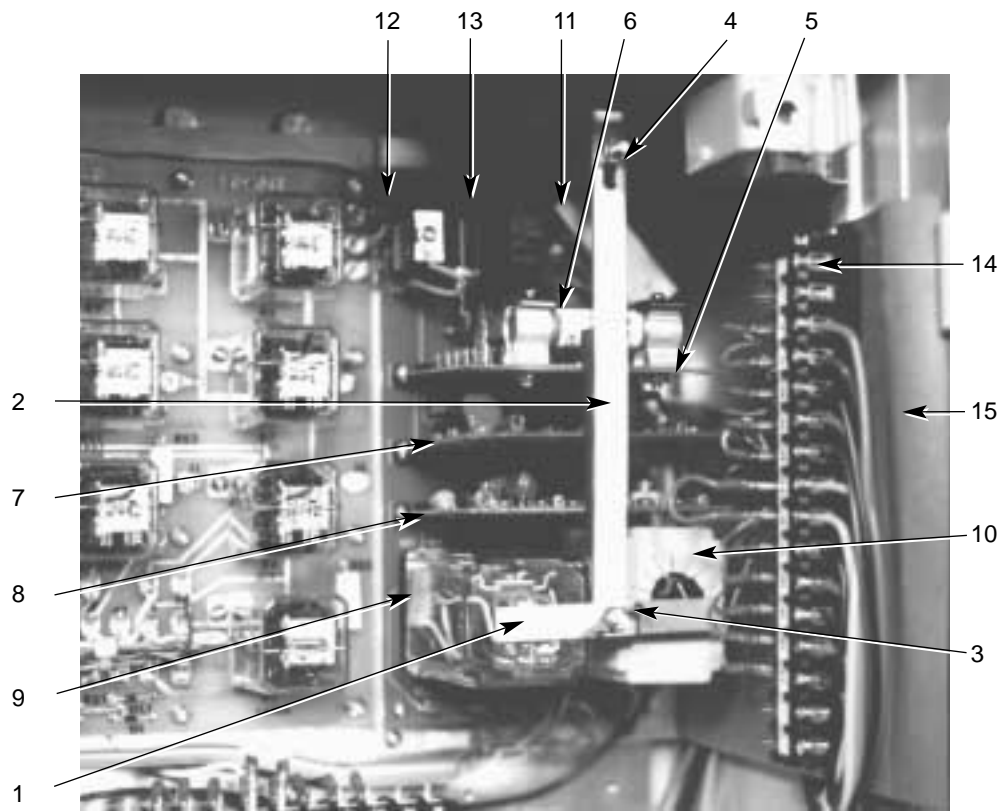

Figure 30.
Fault block accessory – replacement parts identification.

020081KM

Fault Block Accessory Replacement Parts List

Index No.	Description	Catalog Number	Qty.
1	Relay retainer bar	KCN144S1	1
2	Circuit board retainer bar	KCN141S1	1
3	Wing nut, 10-32, stl	K881215332010Z	1
4	Elastic stop nut	KP2020A1	1
5	Phase actuating current circuit board (add proper current value to complete catalog number: 80, 112, 160, 224, 320, 448, 640)	KCN116S__	1
6	Ground actuating current resistor (add proper current value to complete catalog number: 10, 14, 20, 28, 40, 56, 80, 112, 160, 224, 320, 448)	KCN142S__	1
7	Diode board	KCN114SA	1
8	Trip-reset board	KCN112SA	1
9	Relay (RY1)	KP978ME	1
10	Time-delay relay (RY2)	K999904310339A	1
11	Transformer	KA234ME	1
12	Zener diode	KP4011A12	1
13	Tie board	KCN110SA	1
14	Terminal block (TB5) (Consists of the following components)		1
	Terminal section	KP999904150097A	16
	End piece	KP999904150064A	1
	Marker strip	KP2076A50	1
15	Barrier	KCN167S1	1

