

# OWNER'S MANUAL

- ASSEMBLY
- OPERATION
- MAINTENANCE
- PARTS LIST

**Model No.  
249-640A**

## **Important:**

**Read Safety Rules and  
Instructions Carefully**

**5 H.P.  
LOG SPLITTER**

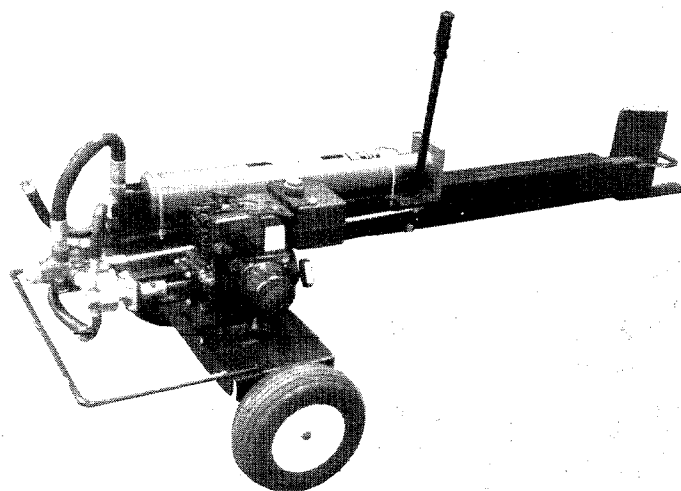

# LIMITED WARRANTY

For one year from the date of original retail purchase, MTD PRODUCTS INC will either repair or replace, at its option, free of charge, F.O.B. factory or authorized service firm, any part or parts found to be defective in material or workmanship. Transportation charges under this warranty must be paid by the purchaser unless return is requested by MTD PRODUCTS INC.

This warranty will not apply to any part which has become inoperative due to misuse, excessive use, accident, neglect, improper maintenance, alterations, or unless the unit has been operated and maintained in accordance with the instructions furnished. This warranty does not apply to the engine, motor, battery, battery charger or component parts thereof. Please refer to the applicable manufacturer's warranty on these items.

This warranty will not apply where the unit has been used commercially.

Warranty service is available through your local authorized service dealer or distributor. If you do not know the dealer or distributor in your area, please write to the Customer Service Department of MTD.

This warranty gives you specific legal rights. You may also have other rights which vary from state to state.

## WARNING TO PURCHASERS OF INTERNAL COMBUSTION ENGINE EQUIPPED MACHINERY OR DEVICES IN THE STATE OF CALIFORNIA

The equipment which you have just purchased does not have a spark arrester. If this equipment is used on any forest covered land, brush covered land, or grass covered unimproved land in the State of California, before using on such land, the California law requires that a spark arrester be provided. In addition, spark arrester is required by law to be in effective working order. The spark arrester must be attached to the exhaust system and comply with Section 442 of the California Public Resources Code.

# ➔ IMPORTANT

It is suggested that this manual be read in its entirety before attempting to assemble or operate. Keep this manual in a safe place for future reference and for ordering replacement parts.

This unit is shipped WITHOUT GASOLINE or OIL. After assembly, see operating section of this manual for proper fuel and amount.

Your log splitter is a precision piece of power equipment, not a plaything. Therefore exercise extreme caution at all times.

## SAFE OPERATION PRACTICES FOR LOG SPLITTERS

### TRAINING

1. Know the controls and how to stop quickly--  
READ THE OWNER'S MANUAL.
2. Do not allow children to operate. Do not allow adults to operate it without proper instruction. Only persons well acquainted with these rules of safe operation should be allowed to use your log splitter.
3. Open doors if engine is run in garage--exhaust fumes are dangerous. Do not run engine indoors.
6. Always operate the log splitter from the engine side of the beam.

### PREPARATION

1. Do not wear loose fitting clothing that could get caught on the moving parts.
2. Do not operate equipment when barefoot or wearing open sandals. Always wear substantial footwear.
3. Check the fuel before starting the engine. Do not fill the gasoline tank indoors, when the engine is running, or while the engine is still hot. Wipe off any spilled gasoline before starting the engine.
4. Use only in daylight or in good artificial light.
5. Never operate the equipment in the rain. Always be sure of your footing.

### OPERATION

1. Do not change the engine governor settings or overspeed the engine. Excessive engine speeds are dangerous.
2. Do not put hands or feet near rotating or moving parts.
3. If the equipment should start to vibrate abnormally, stop the engine and check immediately for the cause. Vibration is generally a warning of trouble.
4. When cleaning, repairing or inspecting, make certain all moving parts have stopped. Disconnect the spark plug wire, and keep the wire away from the plug to prevent accidental starting.

Handle gasoline with care--it is highly flammable.

- A. Use approved gasoline container.
- B. Never remove cap or add gasoline to a running or hot engine or fill fuel tank indoors. Wipe up spilled gasoline.

Stand behind the ram when operating. See drawings.

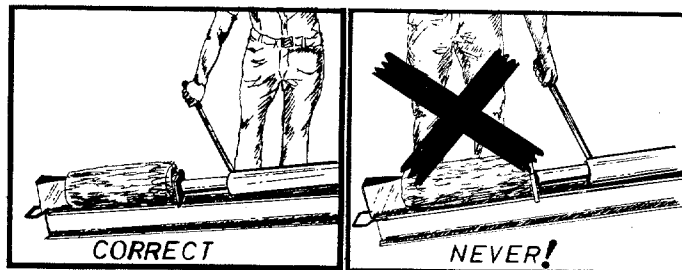

7. Be careful not to touch the muffler after the engine has been running, it is HOT.

### MAINTENANCE and STORAGE

1. Keep all nuts, bolts, screws, hose clamps and hydraulic fittings tight to be sure equipment is in safe working condition.
2. Never store the equipment with gasoline in the tank inside of a building where fumes may reach an open flame or spark. Allow the engine to cool before storing in any enclosure.
3. To reduce fire hazard keep engine free of grass, leaves, wood chips, excessive grease and oil.
4. Do not change the engine governor settings or overspeed the engine. Excessive engine speeds are dangerous.
5. Never store outside without a waterproof cover. Rain will cause rust on the inside of the cylinder.

## TOOLS REQUIRED:

- (1) 1-1/8" wrench or adjustable wrench
- (2) 1/2" wrenches
- (1) 3/4" wrench
- (2) 7/16" wrenches
- (2) 9/16" wrenches

## OTHER MATERIALS NEEDED:

- (A) One gallon or regular grade gasoline (for engine)
- (B) 2-3/4 pints of SAE 30 or 10W oil (for engine)
- (C) 2-1/2 gallons of 10W 30 H.D. oil only (for Splitter)
- (D) Cleaning rag
- (E) Funnel
- (F) Hydraulic sealant tape (for pipe threads)

## LIST OF CONTENTS IN HARDWARE PACK: See figure 1.

- A. (2) Sq. Head Set Screws
- B. (2) Collars
- C. (2) Spacers
- D. (1) Hex Nut 3/8-24 Thread
- E. (1) Pivot Bushing
- F. (1) Hair Pin Cotter
- G. (4) Hex Screws 5/16-24 x 1.00" long
- H. (4) Lockwashers 5/16" Scr.
- I. (4) Hex Nuts 5/16-24 Thread
- J. (1) Shoulder Bolt
- K. (1) Hex Nut 3/8-16 Thread
- L. (1) Stud 3/8-16 x 2.75" Long
- M. (1) Hose Clamp
- N. (1) Shoulder Bolt
- O. (1) Flat Washer
- P. (1) Forward Stroke Stop Bracket
- Q. (1) Hex Screw 1/4-20 x 1.25" Long
- R. (1) Hex Nut 1/4-20 Thread

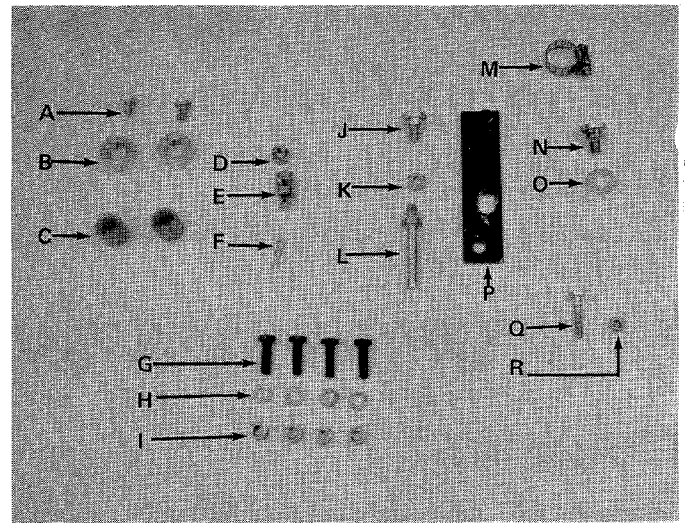

FIGURE 1

Your Log Splitter is shipped in two cartons.

1. Remove the engine (with frame), two wheels engagement rod, engagement handle, hoses and hardware pack. See figures 1 & 2.
2. Remove the beam assembly from the other carton.

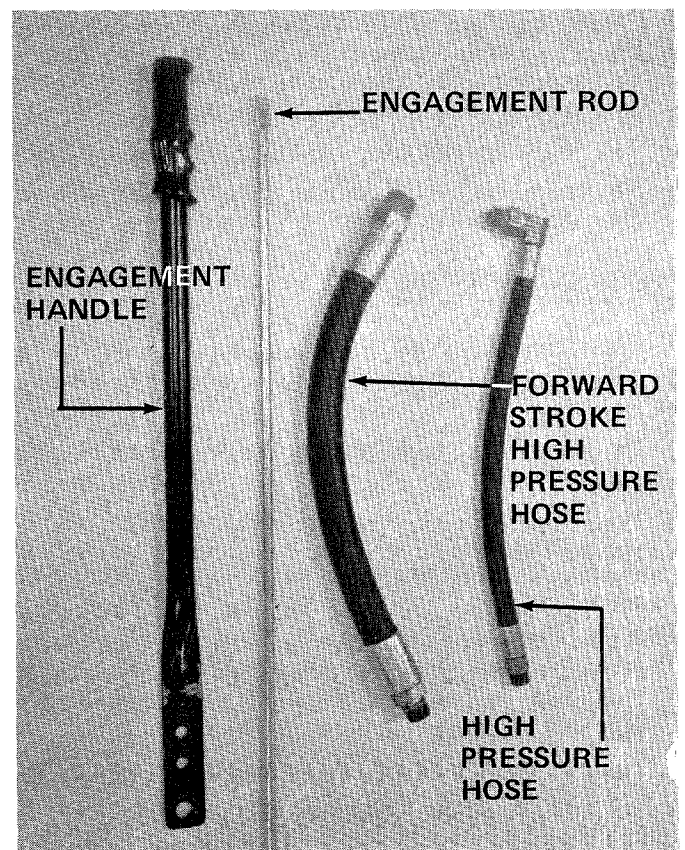

FIGURE 2

# ASSEMBLY INSTRUCTIONS

1. Block up rear end of log splitter so that the rear wheels may be assembled.
2. Place spacers (C) on axle, then wheels and secure with collars (B) and set screws (A). See figure 3.

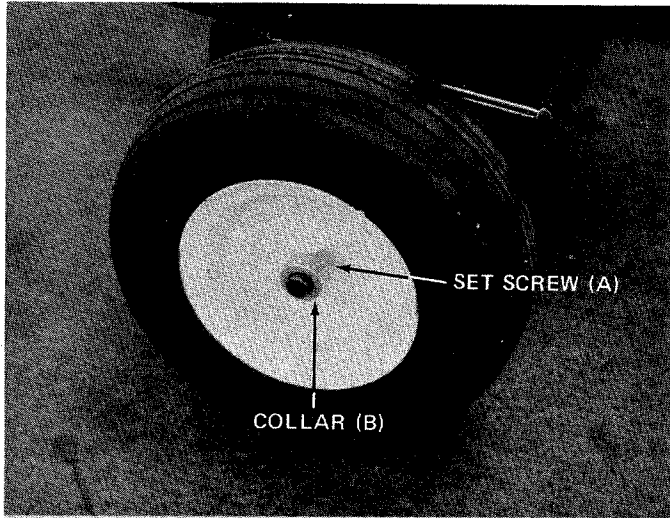

FIGURE 3

3. Place stop bracket (P) through slot in beam. Place engagement handle through slot in beam. See figure 4.
4. Place stud (L) through stop bracket (P) and start hex nut (K) on by hand. See figure 4.

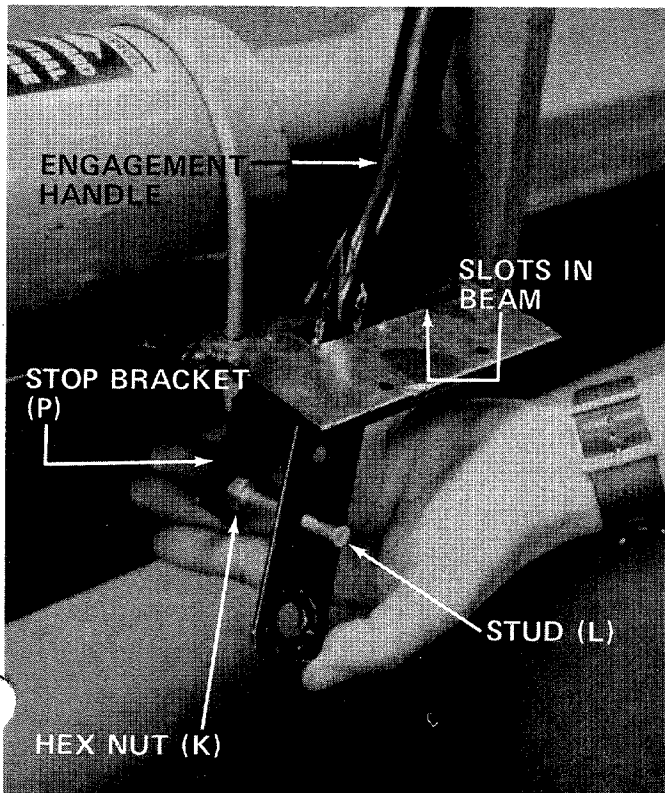

FIGURE 4

5. Place end of stud through the middle hole of engagement handle and then tighten hex nut (K). See figure 4.
6. Secure stop bracket (P) to beam with shoulder bolt (J). See figure 5.

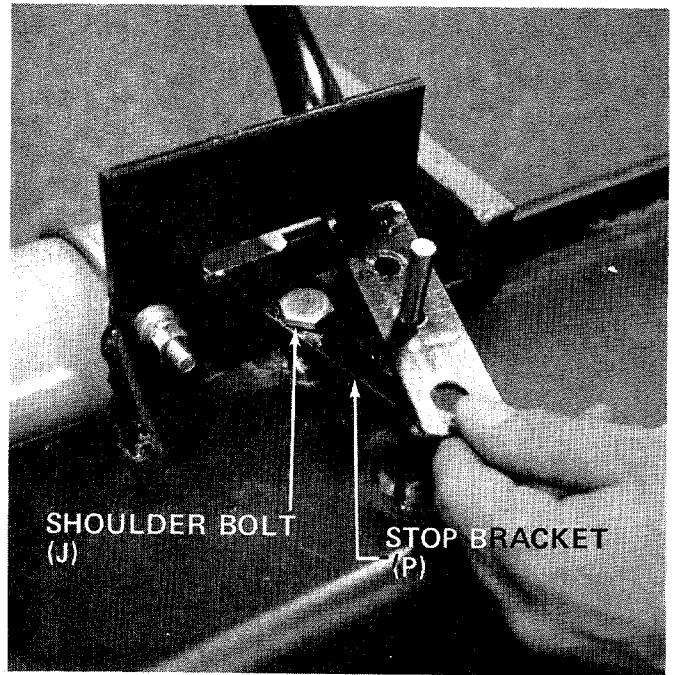

FIGURE 5

7. Secure engagement handle to beam with shoulder bolt (N) and flat washer (O). See figure 6.

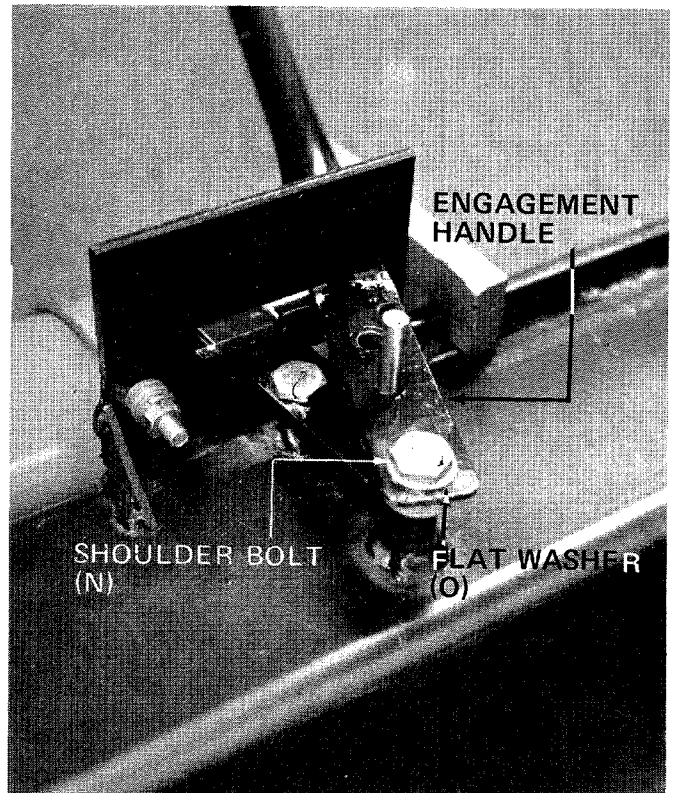

FIGURE 6

- Place end of engagement rod on valve spool and secure with hex screw (Q) and hex nut (R). See figure 7.

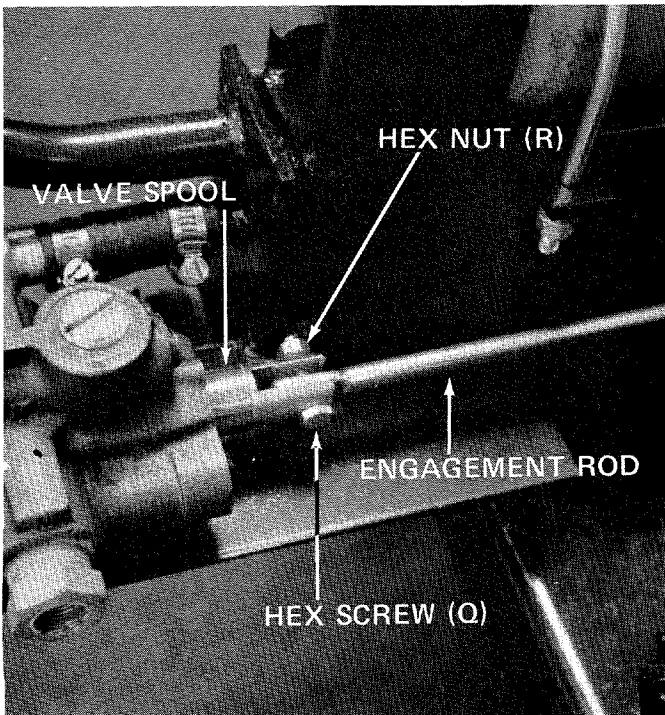

FIGURE 7

- Thread pivot bushing (E) on end of engagement rod so there is approximately 1/2" of thread showing. Engagement handle must be at 90° to beam. Insert pivot bushing (E) into engagement handle. See figure 8.

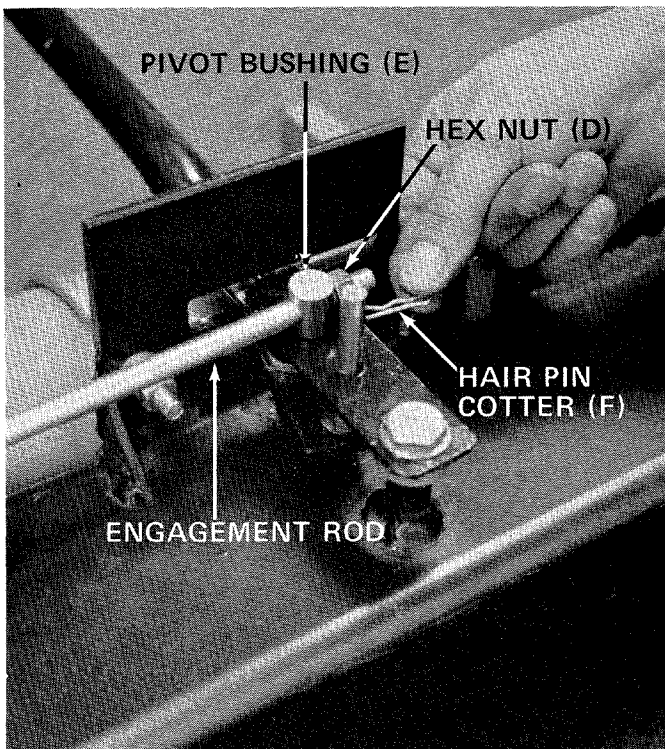

FIGURE 8

**NOTE**

Engagement handle locked in reverse position must depress valve spool to limit.

- Secure pivot bushing in place on engagement rod with hex nut (D).
- Secure the inlet hose to the pump with hose clamp (M), provided in hardware pack. A standard screw driver is required. See figure 9.

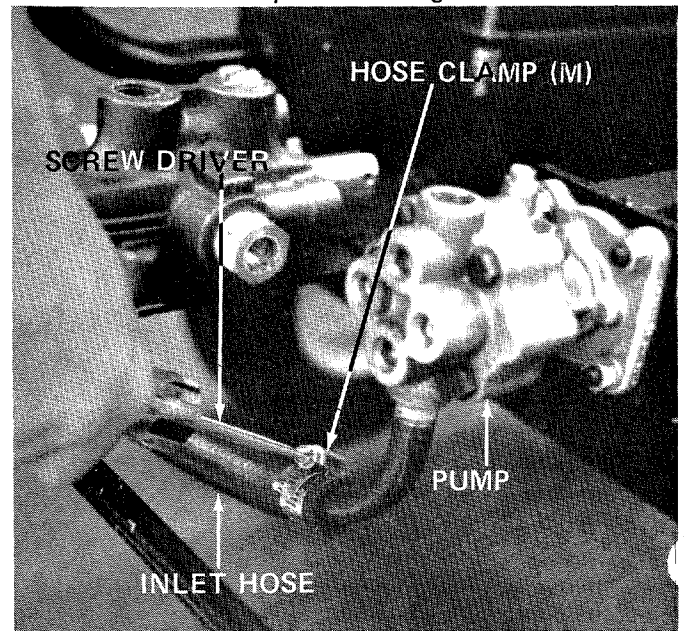

FIGURE 9

- Assemble the forward stroke high pressure hose to the valve. An adjustable wrench is required. See figure 10.

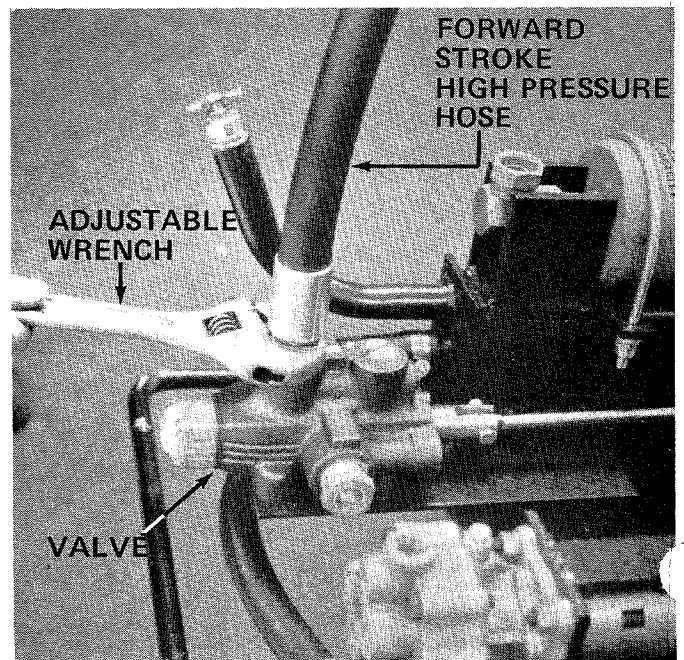

FIGURE 10

**NOTE**

Use hydraulic sealant tape or pipe sealant on threads.

13. Assemble the other end of forward stroke high pressure hose to 90° pipe adapter. (Located at rear of cylinder). See figure 11. An adjustable wrench is required.

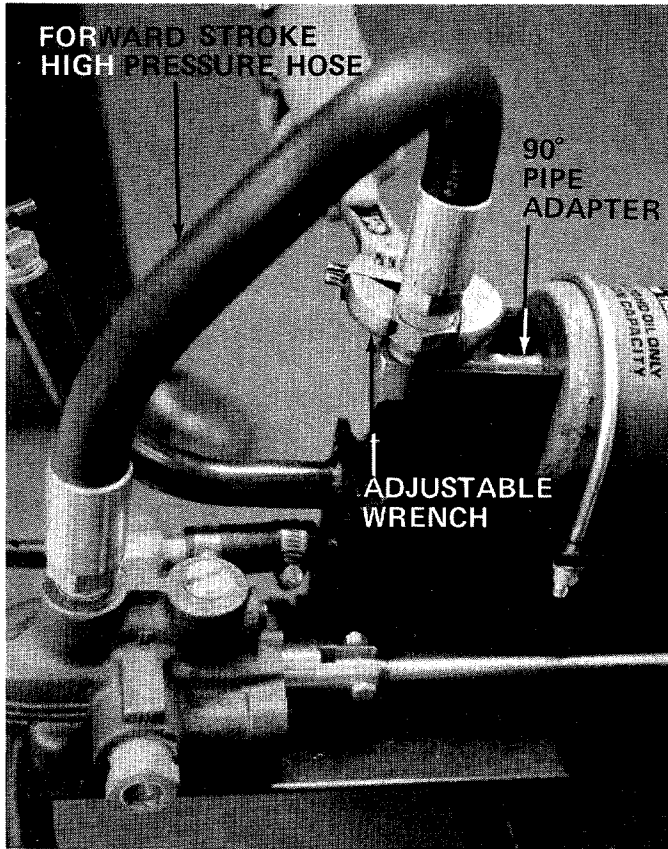

FIGURE 11

14. Assemble high pressure hose to pump. See figure 12. An adjustable wrench is required.

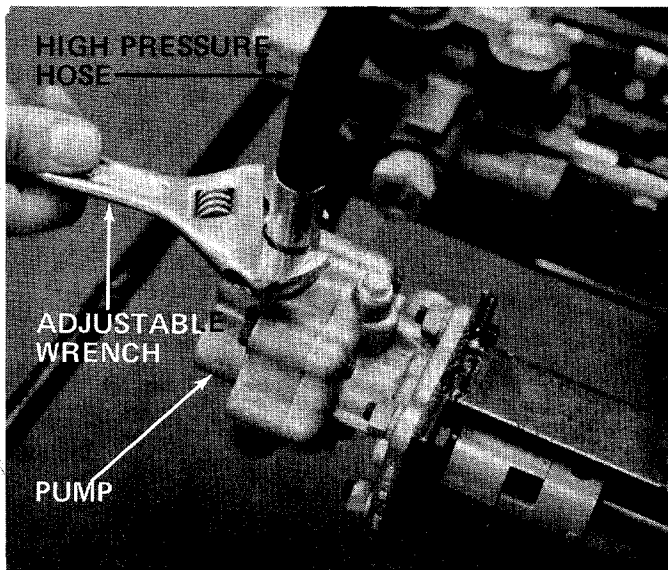

FIGURE 12

15. Assemble other end of high pressure hose to valve. See figure 13. An adjustable wrench is required.

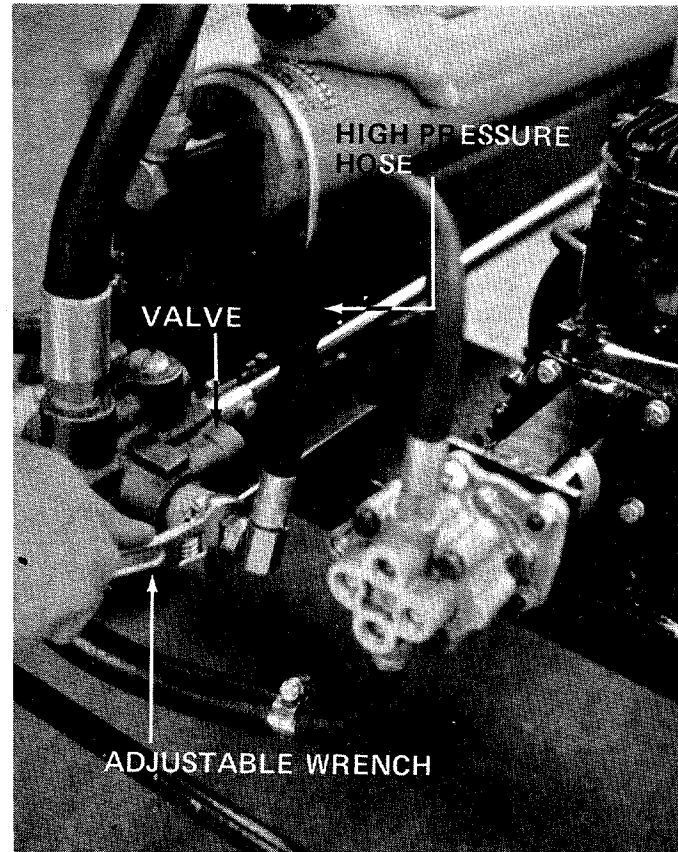

FIGURE 13

## OPERATION

1. Service engine with gas and oil. See engine manual packed with log splitter for complete instructions for the care and maintenance of engine. READ DIRECTIONS CAREFULLY.



You must not operate log splitter without proper amount of oil in reservoir tank.

- 7 Remove the breather plug from breather tube. See figure 14. Pour 2-1/2 gallons of 10W30 H.D. oil ONLY into breather tube.

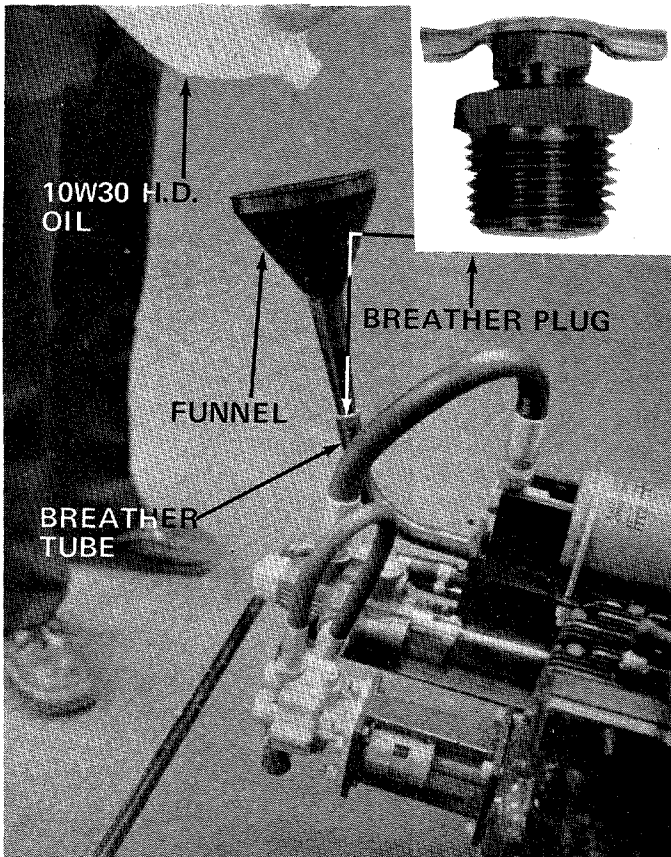

FIGURE 14

**LOG SPLITTER:**

The oil in the reservoir should be changed every (100) hours of operation.

Check oil in log splitter reservoir before every use. See figure 16.

1. Block up front of log splitter so beam is setting level.
2. Remove check pipe plug in rear of beam. See figure 16. If oil starts to come out of check pipe plug hole, oil level is correct. IF NOT add oil to breather tube (figure 14) until oil starts out.



Use hydraulic sealant tape or pipe sealant on pipe plug threads.

3. Open the breather valve. Valve must be open when running log splitter. Valve must be closed when transporting log splitter. See figure 15.

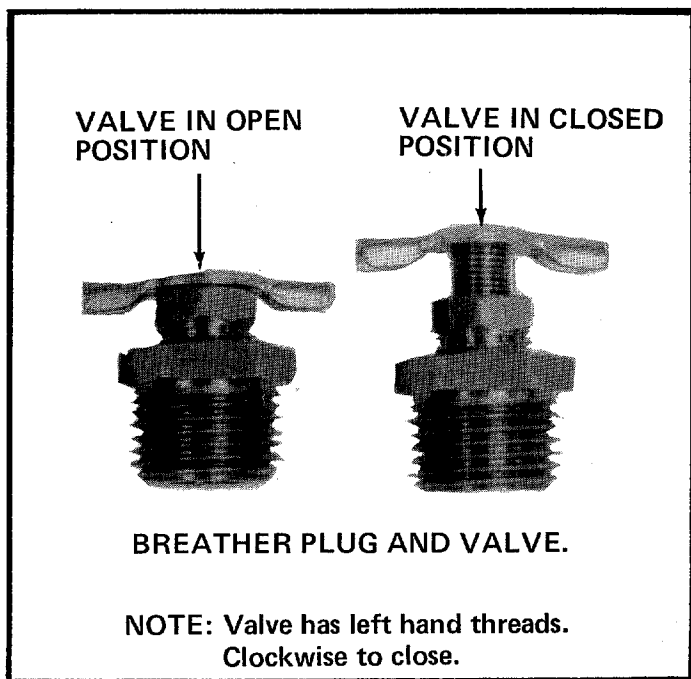

FIGURE 15

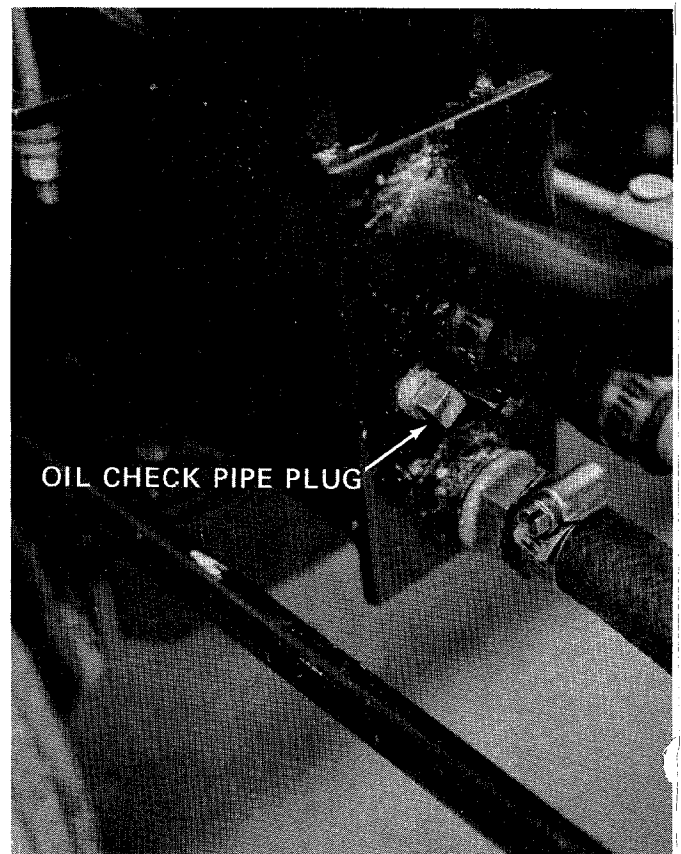

FIGURE 16



## BEFORE STARTING

During initial break-in period, oil level should be watched closely. See ENGINE MAINTENANCE.

Use MS classification oil. Do not use oils marked only MM or ML or unmarked.

Above 32° use ASE 30; below 32° use SAE 10W. These recommendations must be followed for best performance and long life.

Change oil first two (2) hours of operation and check oil level every five (5) operating hours or each time equipment is used.

Change oil every twenty-five (25) operating hours or sooner if equipment is operated in extremely dusty or dirty conditions. See figure 17.



Carburetors are preset at the factory. DO NOT attempt to make adjustments at this time. See carburetor instructions outlined under CARBURETOR ADJUSTMENT.

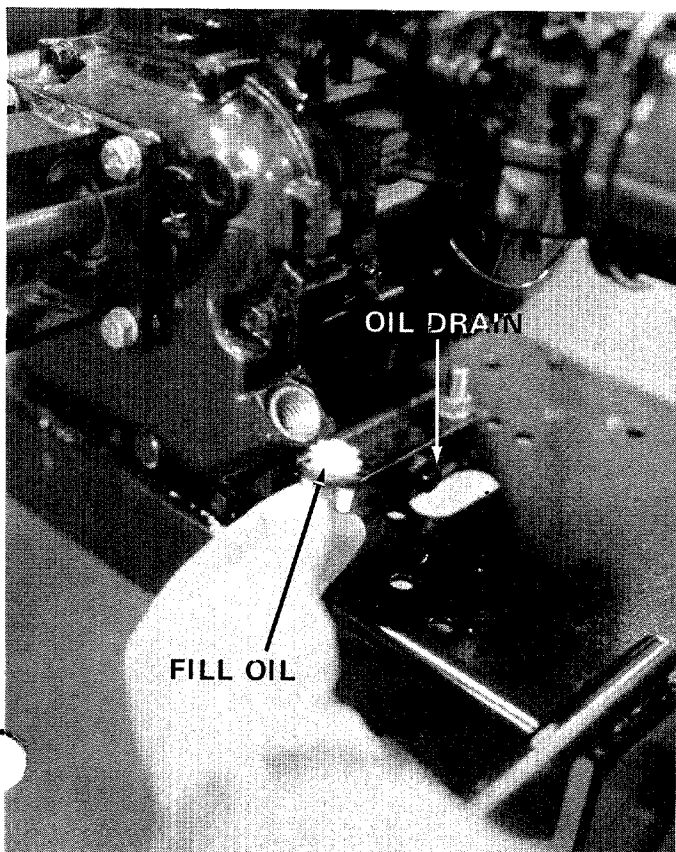

FIGURE 17

## TO START ENGINE

1. Place control lever (on engine) in run position. See figure 18.
2. Move choke lever to CHOKE position. See figure 19.
3. Rewind starter—use quick full arm stroke. Keep firm grip on handle and return rope slowly.

## TO STOP ENGINE

1. Move control lever to STOP position. See figure 18.
2. Remove high tension wire from spark plug to prevent accidental starting by children while equipment is unattended.

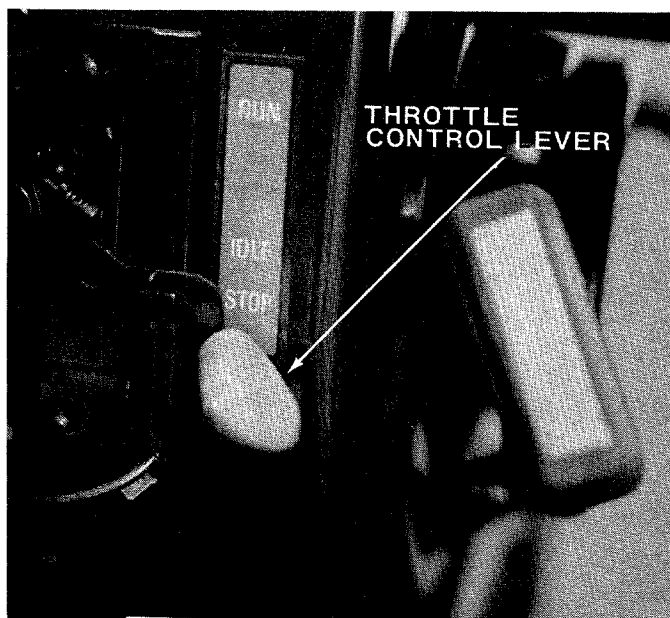

FIGURE 18

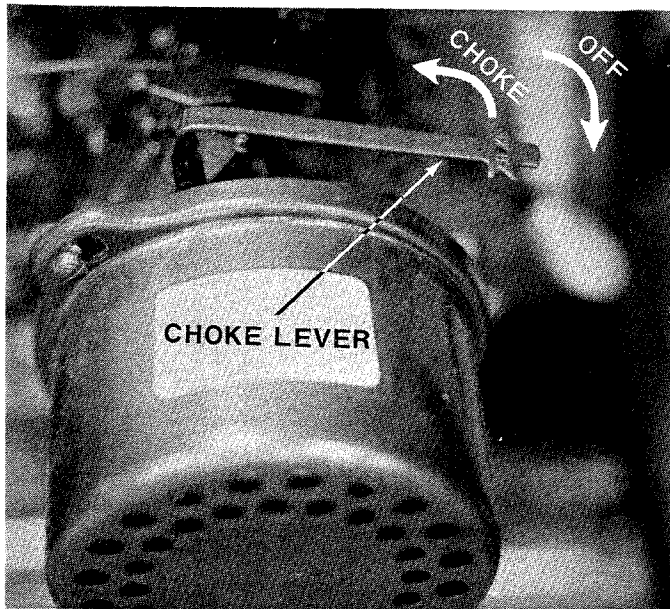

FIGURE 19

## USING YOUR LOG SPLITTER

Your log splitter is designed for safe, efficient, operation. CARE, OF COURSE, MUST BE EXERCISED THAT HANDS ARE KEPT AWAY FROM MOVING PARTS.

- A. Set throttle at maximum speed.
- B. Engagement handle has three positions: Forward—moves ram toward wedge. Neutral—ram stops in place. Reverse—ram returns. See figure 20.

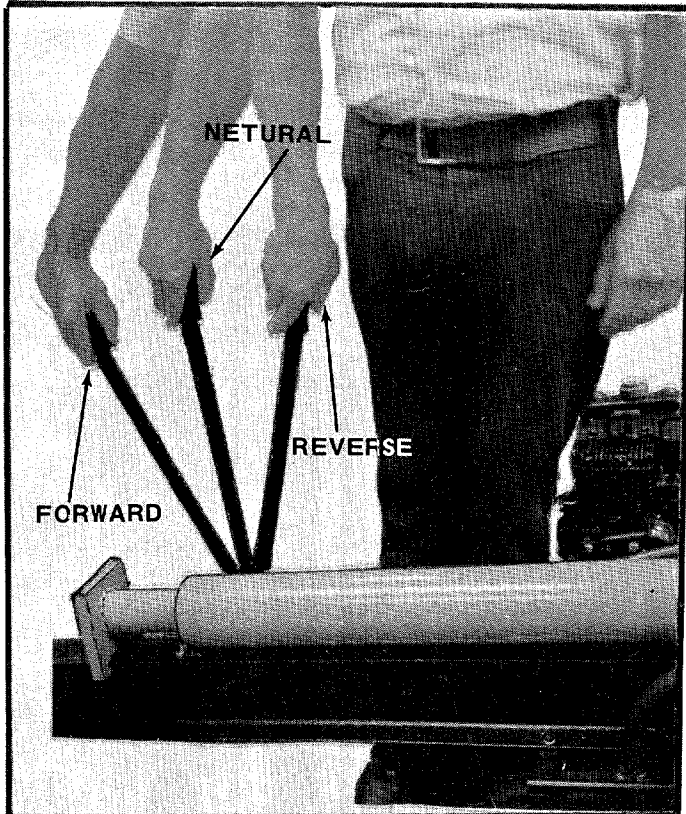

FIGURE 20

- C. Maximum length that can be split is 23".
- D. Place log on beam and hold in place with right hand. See figure 21.

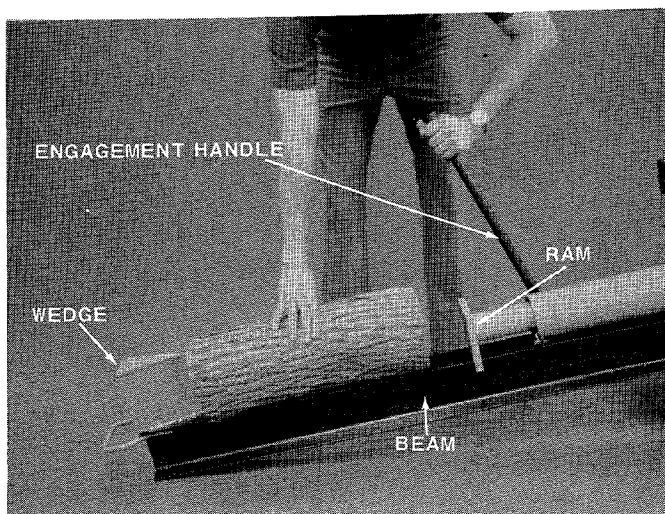

FIGURE 21

- E. Slowly move engagement handle forward until ram rests against log. Release engagement handle (Neutral).
- F. Remove your hand from the log and step behind the ram. See figure 22.

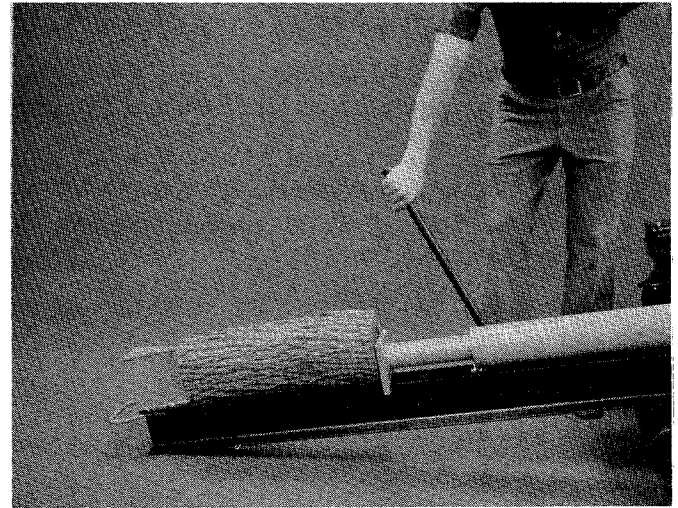

FIGURE 22

- G. Move engagement handle forward until log is split.



If you attempt to run the ram beyond its normal stroke it will automatically return the engagement handle to neutral.

- H. Move the engagement handle to the rear to return ram.



Never attempt to cut a log in half with the log splitter. See figure 23.

Never stand next to the ram when operating. See figure 24. Always stand behind the ram.

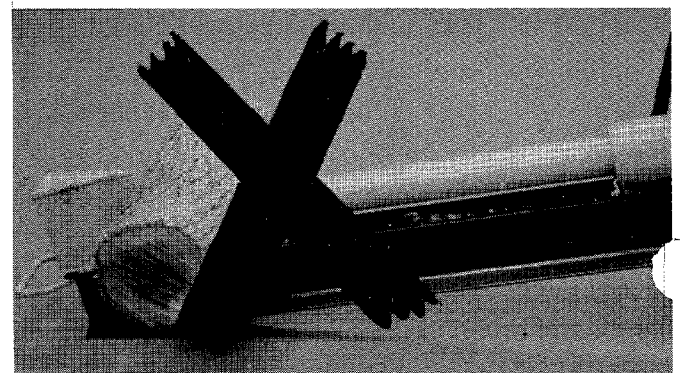

FIGURE 23



FIGURE 24



The ram should take approximately 30 seconds to make a complete cycle. This speed may vary depending on throttle setting and temperature of oil.

## MAINTENANCE



**WARNING**

Always stop engine and disconnect spark plug wire before doing any maintenance.

### RAM OPERATION

If the ram does not move smoothly, run the ram its full stroke several times to clear out air in the system. Be sure the breather valve is open.

If this does not correct the problem see strainer tube assembly paragraph.



When the pressure relief valve opens a loud high pitched sound is heard and engine labors.

### HOSE CLAMPS

Check the hose clamps on the bottom of the pump for proper tightness before each use.

Hose clamps on the return hose should be checked once a season.

### STRAINER TUBE ASSEMBLY

If the ram does not move back and forth smoothly the strainer tube assembly may be clogged.

To clean follow these steps.

1. Remove the hose clamp at inlet hose (bottom hose on rear of beam).



Be prepared to catch oil in some container.

2. Pull off inlet hose from strainer tube assembly and catch oil in a suitable container. See figure 25.
3. With an adjustable wrench remove the strainer tube assembly. See figure 25.

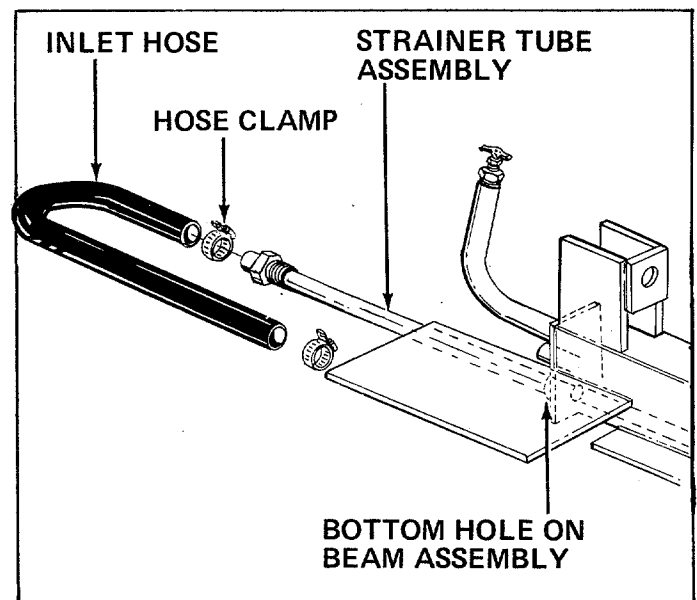

FIGURE 25



The strainer tube assembly is 53" long.

4. Clean and reassemble using a hydraulic pipe sealant on the threads.

### PRESSURE RELIEF VALVE SETTING

If the pressure relief valve is set too low it will open up before enough pressure is built up to properly operate the ram. See figure 26.

### TO SET THE PRESSURE RELIEF VALVE

1. Have someone place a log crossways in the Splitter and allow the Ram to push against it with the engine running wide open.
2. If the engine begins to lug down, the Relief Valve setting is correct.
3. If adjustment is necessary, tighten the screw until the engine begins to lug down.

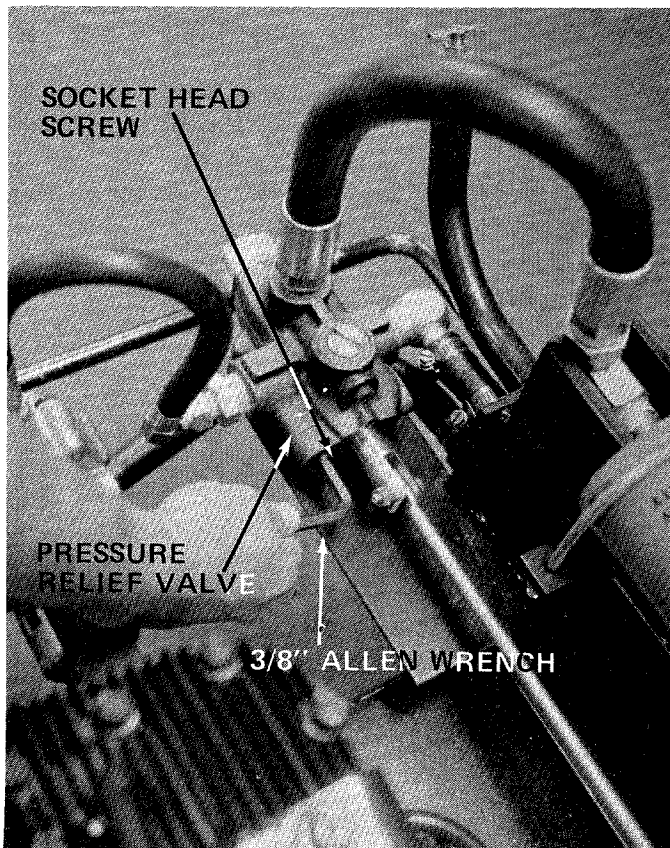

FIGURE 26

## ENGINE MAINTENANCE

To obtain long life and trouble-free service from your engine, certain normal maintenance must be performed as outlined below:

1. Change oil in crankcase after first two (2) hours of operation. Then, follow instructions outlined on page 9.

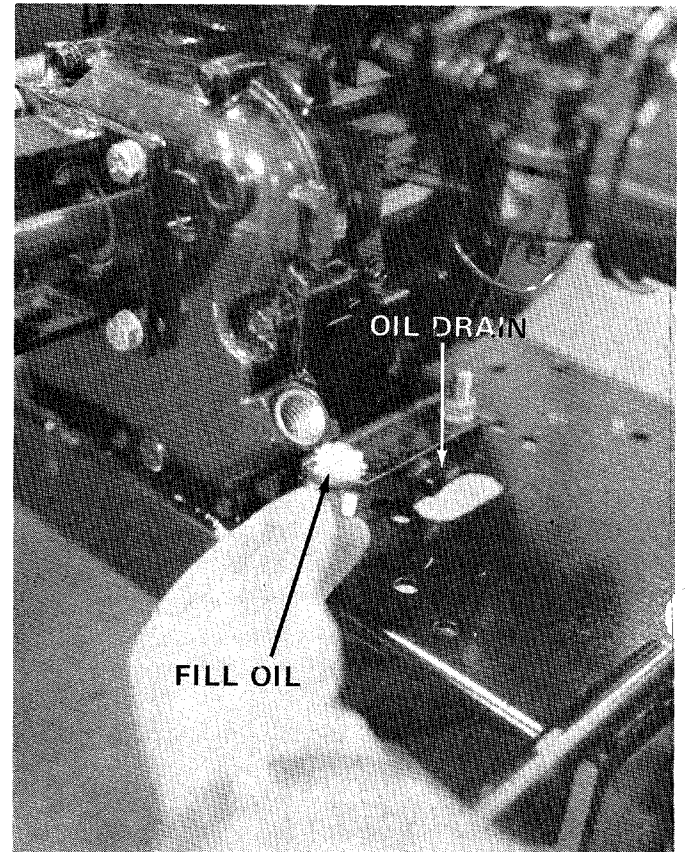

FIGURE 27



**CAUTION**

Disconnect high tension wire at spark plug to prevent accidental starting of engine. Unscrew oil drain plug located on side at bottom of engine See figure 27.



**NOTE**

Always tip engine towards oil drain hole. Be sure oil drains completely.

Replace oil drain plug and refill with oil as directed on page 5 or engine nameplate.

2. Check oil every five (5) operating hours or each time equipment is used.

- Cleaning engine—This is an aircooled engine which operates most efficiently when the cooling fins are clean.

Clean cylinder fins and underside of tank or housing thoroughly of all accumulated grass and debris.

- Air Cleaner. (See figure 28).
  - Paper Type Element. Remove every 10 hours or oftener if under dusty conditions. Tap to remove loose dirt and/or blow from inside out with low pressure air. Replace if torn or perforated or when plugged to maintain proper carburetor setting (50 hours). **DO NOT WASH IN ANY LIQUID AND DO NOT OIL.**

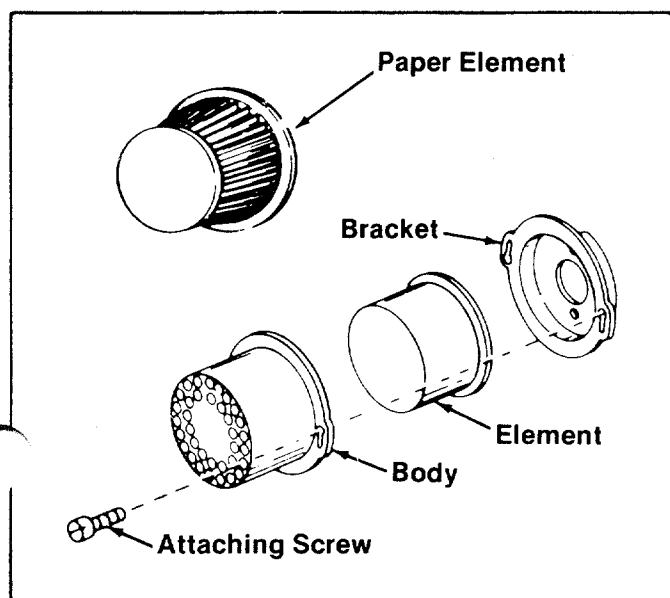

FIGURE 28

### CARBURETOR ADJUSTMENTS (See figure 29)

Do not make unnecessary adjustment. Factory settings are correct for most application. If adjustments are needed, proceed as follows:

- Close power adjusting needle (figure 29) by turning to right (clockwise). Close finger tight only. Forcing will cause damage.
- Open one turn (counterclockwise).
- Close idle adjusting needle (figure 29) by turning to right (clockwise). Close finger tight only. Forcing will cause damage.
- Open one and one-half (1-1/2) turns (counterclockwise).
- Start engine. Follow starting instructions page 5.

With throttle open (carburetor control at RUN or FAST position) adjust power adjusting needle one-eighth (1/8) turn at a time forward to backward until engine runs smoothly. If engine tends to stall under load enrich mixture slightly (counterclockwise).

- Hold throttle lever closed or move carburetor control to IDLE or SLOW position and adjust idle adjusting needle until engine runs smoothly proceeding in step six (6) above.
- Allow several seconds between each adjustment when performing either step six (6) or seven (7) to allow engine to react to new setting.

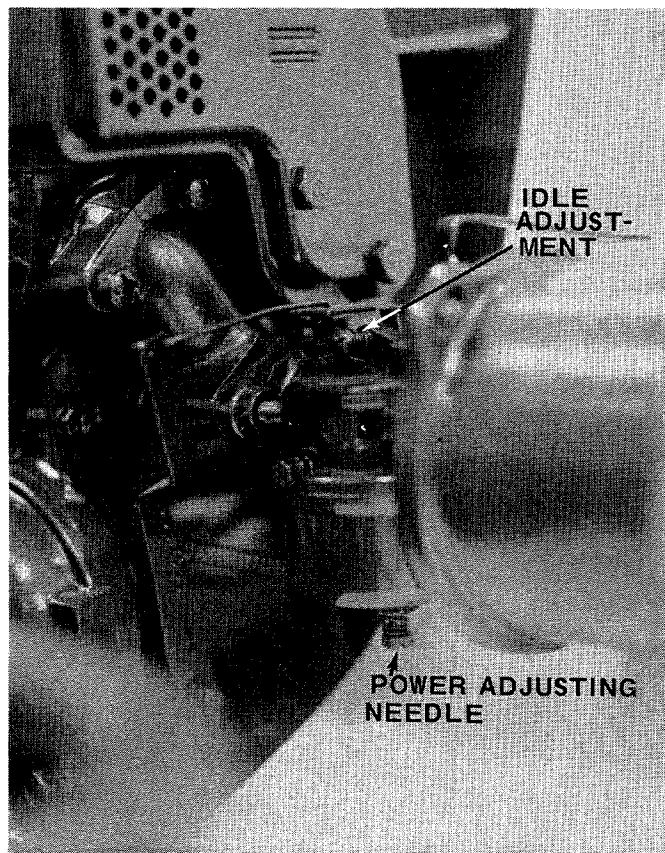

FIGURE 29

## STORAGE INSTRUCTIONS

In event engine is to be stored for any length of time (30 days or more), prepare as follows:

- Drain gasoline by tipping or by syphon hose, then run engine until remainder is used and tank and carburetor are empty.



Drain into container outdoors away from fire or flame.

- Drain carburetor by running engine until it stops
- Inside protecting of engine for storage is performed by removing spark plug and pouring one ounce of SAE 30 oil through spark plug hole into cylinder. Crank engine, without starting, several times to spread oil over cylinder walls.
- Never store outside without a waterproof cover.

# 249-640A

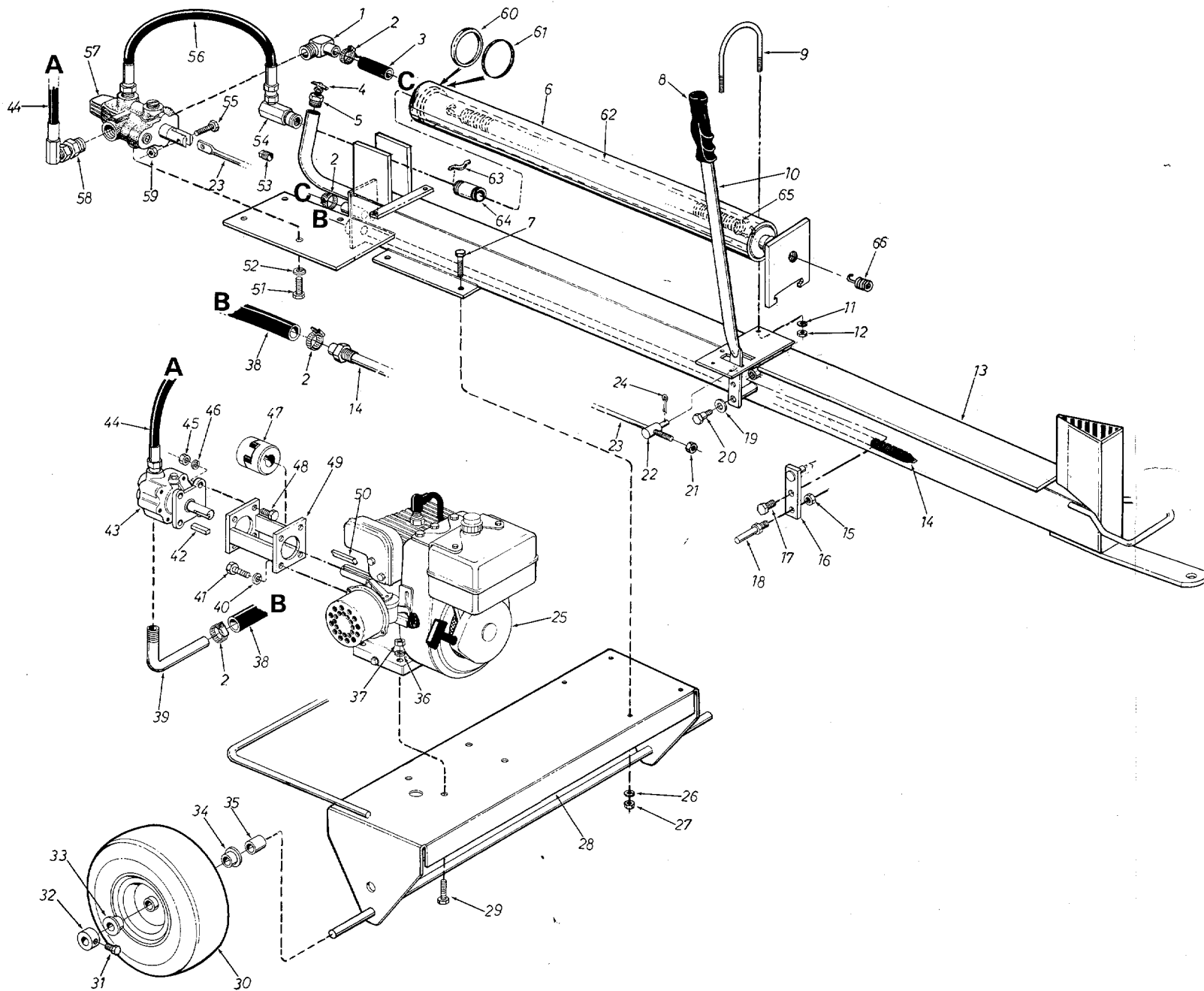

**PARTS LIST FOR LOG SPLITTER MODEL No. 249-640A**

Ref. No.	Part No.	Color Code	DESCRIPTION	New Part	Ref. No.	Part No.	Color Code	DESCRIPTION	New Part
1	737-0153		Return Elbow		34	748-0184		Flange Bearing .630" I.D.	
2	726-0173		Hose Clamp		35	748-0192		Spacer .63" I.D. x .88" O.D. x .800" Lg.	
3	727-0210		Return Hose 3/4" I.D. x 2.62" Lg.		36	736-0119		L.-Wash. 5/16" Scr.*	
4	737-0161		Breather Valve		37	712-0123		Hex Nut 5/16-24 Thd.*	
5	737-0160		Breather Plug		38	727-0215		Inlet Hose 3/4" I.D. x 14" Lg.	N
6	13304		Cylinder Ass'y.		39	750-0439		Pump Inlet Tubing	N
7	710-0117		Hex Scr. 5/16-24 x 1.00" Lg.		40	736-0119		L.-Wash. 5/16" Scr.*	
8	08118		Grip		41	710-0157		Hex Scr. 5/16-24 x .75" Lg.*	
9	747-0289		Cylinder Support Rod		42	-----		Sq. Key come with Ref. No. 43	43
10	750-0428		Engagement Handle	N	43	717-0363		Pump with Sq. Key 1/8 x 1/8 x 1.00" Lg.	
11	736-0119		L.-Wash. 5/16" Scr. *		44	727-0203		High Pressure Hose	
12	712-0267		Hex Nut 5/16-18 Thd.*		45	712-0123		Hex Nut 5/16-24 Thd.*	
13	13744		Complete Oil Tank & Beam Ass'y.		46	736-0119		L.-Wash. 5/16" Scr.*	
14	13677		Strainer Tube Ass'y.		47	717-0374		Flexible Coupling with Set Scr.	
15	712-0266		Hex Cent. L.-Jam Nut 3/8-16 Thd.		48	710-0117		Hex Scr. 5/16-24 x 1.00" Lg.*	
16	13769		Forward Stroke Stop Brkt. Ass'y.	N	49	13295		Coupling Support Brkt. Ass'y.	
17	738-0183		Shld. Scr. .500" Dia. x .215		50	714-0128		Sq. Key 1/4 x 1/4" x 1.00" Lg.*	
18	711-0640		Stud 3/8-16 x 2.75" Lg.		51	710-0216		Hex Scr. 3/8-16 x .75" Lg.*	
19	736-0160		Fl.-Wash. .53" I.D. x .94" O.D.		52	736-0105		Belleville Wash. .405 I.D. x .88 O.D.	
20	738-0234		Shld. Scr. .500" Dia. x .295		53	737-0104		Pipe Plug 1/4-18 Pipe Thd.	
21	712-0241		Hex Nut 3/8-24 Thd.*		54	737-0163		90° Pipe Adapter	N
22	711-0198		Pivot Bushing		55	710-0106		Hex Scr. 1/4-20 x 1.25" Lg.*	
23	747-0297		Engagement Rod .38 Dia. x 31" Lg.	N	56	727-0216		Forward Stroke High Pressure Hose	N
24	714-0507		Cotter Pin 3/32" Dia. x .75"		57	717-0408		Control Valve	N
25	-----		5 H.P. Engine-Tecumseh		58	737-0155		Reducing Bushing	
26	736-0119		L.-Wash. 5/16" Scr. *		59	712-0107		Hex L.-Nut 1/4-20 Thd.	
27	712-0123		Hex Nut 5/16-24 Thd.*		60	721-0164		Back-up Ring	
28	13748		Frame Ass'y.	N	61	721-0159		"O"-Ring	
29	710-0409		Hex Scr. 5/16-24 x 1.75" Lg.*		62	13767		Push Cylinder Ass'y.	N
30	734-0488		Wheel Ass'y. Comp. 11.0x4.0		63	732-0342		Spring Clamp	
31	710-0494		Sq. Hd. Set Scr. 5/16-18 x .38 Cup Point		64	737-0162		Cylinder Nipple 3/4 Pipe Thd. x 2.00" Lg.	N
32	711-0169		Collar 5/8" I.D.		65	732-0363		Cylinder Return Spring	N
33	748-0184		Flange Bearing .630" I.D.		66	13314		Spring Hook Ass'y.	N

\*For faster service obtain standard nuts, bolts and washers locally. If these items cannot be obtained locally, order by part number and size as shown on parts list.

The engine is not under warranty by the log splitter manufacturer. If repairs or service is needed on the engine, please contact your nearest authorized engine service outlet. Check the "Yellow Pages" of your telephone book under "Engines - Gasoline."

**Find It Fast  
In The  
Yellow Pages**

# PARTS INFORMATION

## POWER EQUIPMENT PARTS AND SERVICE

Parts and service for all MTD manufactured power equipment are available through the authorized service firms listed below. All orders should specify the model number of your unit, parts number, description of parts and the quantity of each part required.

<b>ALABAMA</b>	<b>BIRMINGHAM</b>	
Auto Electric & Carburetor Co. ....	2625 4th Ave. S. ....	35233
<b>ARKANSAS</b>	<b>NORTH LITTLE ROCK</b>	
Sutton's Lawn Mower Shop .....	Rt. 4, Box 368 .....	72117
	<b>FORT SMITH</b>	
Mity Mite Motors, Inc. ....	2515 Towson Ave. ....	72901
<b>CALIFORNIA</b>	<b>PORTERVILLE</b>	
Billious .....	75 North D Street .....	93257
	<b>SAN BERNARDINO</b>	
Lawn Mower Supply Co. ....	25608 E. Baseline .....	92410
	<b>SAN FRANCISCO</b>	
J.W. Jewett Co. ....	981 Folsom St. ....	94107
	<b>SACRAMENTO</b>	
Luttig & Severson .....	2030 28th St. ....	95818
<b>COLORADO</b>	<b>DENVER</b>	
South Denver Lawn Equip. ....	527 West Evans .....	80223
<b>CONNECTICUT</b>	<b>SUFFIELD</b>	
The Jones & Ramsey Co. ....	850 Thompsonville Rd. ....	06078
<b>FLORIDA</b>	<b>JACKSONVILLE</b>	
Radco Distributors .....	2403 Market St. ....	32206
	<b>CORAL GABLES</b>	
Moz-All of Florida, Inc. ....	365 Greco Ave. ....	33146
<b>GEORGIA</b>	<b>EAST POINT</b>	
East Point Cycle & Key .....	2834 Church St. ....	30344
<b>ILLINOIS</b>	<b>LYONS</b>	
Keen Edge Co. ....	8615 Ogden Ave. ....	60534
<b>INDIANA</b>	<b>ELKHART</b>	
Parts & Sales Inc. ....	2101 Industrial Pkwy. ....	46514
<b>IOWA</b>	<b>DUBUQUE</b>	
Power Lawn & Garden Equip. ....	2551 J.F. Kennedy .....	52001
<b>LOUISIANA</b>	<b>NEW ORLEANS</b>	
Suhren Engine Co. ....	8330 Earhart Blvd. ....	70118
<b>MARYLAND</b>	<b>TAKOMA PARK</b>	
Center Supply Co. ....	6867 New Hampshire Ave. ....	20012
<b>MASSACHUSETTS</b>	<b>SPRINGFIELD</b>	
Morton B. Collins Co. ....	300 Birnie Ave. ....	01107
<b>MICHIGAN</b>	<b>MOUNT CLEMENS</b>	
Power Equipment Dist. ....	36463 South Gratiot .....	48043
	<b>LANSING</b>	
Lorenz Service Co. ....	2500 S. Pennsylvania .....	48900
<b>MINNESOTA</b>	<b>MINNETONKA</b>	
Hance Distributing Inc. ....	11212 Wayzata Blvd. ....	55343
<b>MISSISSIPPI</b>	<b>BILOXI</b>	
Biloxi Sales & Service, Inc. ....	506 Caillavet St. ....	39533
<b>MISSOURI</b>	<b>KANSAS CITY</b>	
Automotive Equip. Service .....	3117 Holmes St. ....	64109
	<b>ST. LOUIS</b>	
Henzler, Inc. ....	2015 Lemay Ferry Rd. ....	63125
<b>NEW JERSEY</b>	<b>BELLMAWR</b>	
Lawnmower Parts Inc. ....	717 Creek Rd., P.O. Box 7 .....	08030

## BRIGGS & STRATTON, TECUMSEH AND PEERLESS PARTS AND SERVICE

Briggs & Stratton, Tecumseh and Peerless parts service should be handled by your nearest authorized engine service firm. Check the yellow pages of your telephone directory under the listing **Engines—Gasoline**, Briggs & Stratton or Tecumseh Lauson.

<b>NEW YORK</b>	<b>CARTHAGE</b>	
Gamble Dist., Inc. ....	West End Ave. ....	13619
<b>NORTH CAROLINA</b>	<b>GREENSBORO</b>	
Dixie Sales Company .....	327 Battleground Ave. ....	27402
	<b>GOLDSBORO</b>	
Smith Hardware Co. ....	515 N. George St. ....	27530
<b>OHIO</b>	<b>WADSWORTH</b>	
National Central .....	687 Seville Rd. ....	44281
	<b>CLEVELAND</b>	
Bleckrie, Inc. ....	7900 Lorain Ave. ....	44102
	<b>CARROLL</b>	
Stebe's Mid-State Mower Supply .....	Box 366 .....	43112
	<b>WILLARD</b>	
Sunshine Wholesale Tire Outlet .....	Route 224 .....	44890
<b>OKLAHOMA</b>	<b>MUSKOGEE</b>	
Victory Motors, Inc. ....	605 S. Cherokee .....	74401
	<b>ADA</b>	
Ada Auto Supply .....	301 E. 12th St. ....	74820
<b>OREGON</b>	<b>PORTLAND</b>	
Kenton Supply Co. ....	8216 N. Denver Ave. ....	97217
<b>PENNSYLVANIA</b>	<b>LANCASTER</b>	
Raub Supply Co. ....	James & Mulberry Sts. ....	17604
	<b>PITTSBURGH</b>	
Bluemont Co. ....	11125 Frankstown Rd. ....	15235
<b>TENNESSEE</b>	<b>KNOXVILLE</b>	
Master Repair Service .....	2423 Broadway, N.E. ....	37917
	<b>MEMPHIS</b>	
Memphis Cycle & Supply Co. ....	421 Monroe Ave. ....	38111
American Sales & Service, Inc. ....	1922 Lynnbrook .....	38111
<b>TEXAS</b>	<b>DALLAS</b>	
Marr Brothers, Inc. ....	423 E. Jefferson .....	75203
	<b>HOUSTON</b>	
Bullard Supply Co. ....	2409 Commerce St. ....	77003
	<b>SAN ANTONIO</b>	
Catto & Putty, Inc. ....	P.O. Box 2408 .....	78206
	<b>FORT WORTH</b>	
Woodson Sales Corp. ....	1702 N. Sylvania .....	76111
<b>UTAH</b>	<b>SALT LAKE CITY</b>	
A-1 Engine & Mower Co. ....	437 E. 9th St. ....	84111
<b>VERMONT</b>	<b>BURLINGTON</b>	
Vermont Appliance Co. ....	44 Lakeside Ave. ....	05401
<b>VIRGINIA</b>	<b>RICHMOND</b>	
RBI Corp. ....	963 Myers St. ....	23260
<b>WASHINGTON</b>	<b>SEATTLE</b>	
Bailey's Rebuild, Inc. ....	1325 E. Madison St. ....	98102
<b>WEST VIRGINIA</b>	<b>CHARLESTON</b>	
Young's, Inc. ....	233 Virginia St., E. ....	25301
<b>WISCONSIN</b>	<b>APPLETON</b>	
Automotive Supply Co. ....	123 S. Linwood Ave. ....	54911

### WARRANTY PARTS AND SERVICE POLICY

The purpose of warranty is to protect the customer from defects in workmanship and materials, defects which are NOT detected at the time of manufacture. It does not provide for the unlimited and unrestricted replacement of parts. Use and maintenance are the responsibility of the customer. The manufacturer cannot assume responsibility for conditions which it has no control. Simply put, if it's the manufacturer's fault, it's the manufacturer's responsibility; if it's the customer's fault, it's the customer's responsibility.

#### CLAIMS AGAINST THE MANUFACTURER'S WARRANTY INCLUDES

1. Replacement of Missing Parts on new equipment.
2. Replacement of Defective Parts within the warranty period.
3. Repair of Defects within the warranty period.

All claims MUST be substantiated with the following information:

1. Model Number of unit involved.
2. Date unit was purchased or first put into service.
3. Date of failure.
4. Nature of failure.