



FOLDABLE SHOP CRANE 2 TON

Model 46766

ASSEMBLY & OPERATING INSTRUCTIONS



3491 Mission Oaks Blvd., Camarillo, CA 93011
Visit our Web site at <http://www.harborfreight.com>

**TO PREVENT SERIOUS INJURY,
READ AND UNDERSTAND ALL WARNINGS
AND INSTRUCTIONS BEFORE USE.**

Copyright© 2002 by Harbor Freight Tools®. All rights reserved. No portion of this manual or any artwork contained herein may be reproduced in any shape or form without the express written consent of Harbor Freight Tools.

For technical questions and replacement parts, please call 1-800-444-3353.

REV 05/05

THANK YOU for choosing a **HARBOR FREIGHT TOOLS** product. For future reference, please complete the owner's record below:

Model _____

Serial No. _____

Purchase Date _____

Save This Manual

You will need the manual for the safety warnings and precautions, assembly instructions, operating and maintenance procedures, parts list and diagram. Keep your invoice with this manual. Write the invoice number on the inside of the front cover. Keep the manual and invoice in a safe and dry place for future reference.

Technical Specifications

Product Name:	Foldable Shop Crane-2 Ton
Product Number:	46766
Adjust to Heights:	2 T = 42-3/4" H; 1-1/2 T = 49-11/16" H; 1 T = 56-7/8" H 1/2 T = 63-7/8" H
Max Boom Height:	105"
Swivel Hook:	360 Degrees
Dimensions (Folded)	33-1/2" W x 26" L x 66-1/2" H
Dimensions (Unfolded)	35" W x 72" L x 58-3/8" H
Latch:	Spring Loaded
Construction:	All Steel
Ram:	8 Ton
Weight:	255 LBS
Maximum Capacity:	4,000 LBS
Ram Travel:	19-1/4"
Ground Clearance:	1-1/8"
Front Boom Hook:	7" to Hook opening and 9-1/2" to Hook bottom



IMPORTANT SAFETY INSTRUCTIONS!



READ ALL INSTRUCTIONS BEFORE USING THIS PRODUCT!

Safety Warnings and Precautions

WARNING: When using tool, basic safety precautions should always be followed to reduce the risk of personal injury and damage to equipment. Read all instructions before using this tool!

1. **Keep work area clean.** Cluttered areas invite injuries.
2. **Observe work area conditions.** Do not use product in damp or wet locations. Don't expose to rain. Keep work area well lighted.
3. **Keep children away.** Children must never be allowed in the work area. Do not let them handle machines, tools, or extension cords.
4. **Store idle equipment.** When not in use, products must be stored in a dry location to inhibit rust. Always lock up products and tools and keep out of reach of children.
5. **Do not force product.** It will do the job better and more safely at the rate for which it was intended. Do not use inappropriate attachments in an attempt to exceed the product capacity.
6. **Use the right tool for the job.** Do not attempt to force a small tool or attachment to do the work of a larger industrial tool. There are certain applications for which this product was designed. Do not modify this product and do not use this product for a purpose for which it was not intended.

Safety Warnings (cont'd)

7. **Dress properly.** Do not wear loose clothing or jewelry as they can be caught in moving parts. Protective, electrically nonconductive clothes and nonskid footwear are recommended when working. Wear restrictive hair covering to contain long hair.
8. **Use eye and ear protection.** Always wear ANSI approved impact safety goggles. Wear a full face shield if you are producing metal filings or wood chips. Wear an ANSI approved dust mask or respirator when working around metal, wood, and chemical dusts and mists.
9. **Do not overreach.** Keep proper footing and balance at all times. Do not reach over or across running machines.
10. **Maintain products with care.** Keep products clean for better and safer performance. Follow instructions for lubricating and changing accessories.
11. **Remove adjusting keys and wrenches.** Check that keys and adjusting wrenches are removed from the tool or machine work surface before operating.
12. **Stay alert.** Watch what you are doing, use common sense. Do not operate any tool when you are tired.
13. **Check for damaged parts.** Before using any product, any part that appears damaged should be carefully checked to determine that it will operate properly and perform its intended function. Check for alignment and binding of moving parts; any broken parts or mounting fixtures; and any other condition that may affect proper operation. Any part that is damaged should be properly repaired or replaced by a qualified technician.
14. **Replacement parts and accessories.** When servicing, use only identical replacement parts. Use of any other parts will void the warranty. Only use accessories intended for use with this tool. Approved accessories are available from Harbor Freight Tools.
15. **Do not operate product if under the influence of alcohol or drugs.** Read warning labels on prescriptions to determine if your judgment or reflexes are impaired while taking drugs. If there is any doubt, do not operate the tool.
16. **Maintenance.** For your safety, service and maintenance should be performed regularly by a qualified technician.
17. **Do not exceed the products 4,000 Lb. maximum capacity.** Exceeding the maximum capacity may cause damage to the product and may result in serious harm or injury.
18. **Make certain to place the Shop Crane on a flat, sturdy and level surface that is capable of supporting the weight of the Shop Crane and a 4,000 Lb. Load.**

Warning: The warnings, cautions, and instructions discussed in this instruction manual cannot cover all possible conditions and situations that may occur. It must be understood by the operator that common sense and caution are factors which cannot be built into this product, but must be supplied by the operator.

Assembly

Your Foldable Shop Crane will require complete assembly as described in the following steps. To assist you with assembly and operation please refer to the Operational Figures as well as the Assembly Diagram and Parts List located on the last pages of this manual.

Warning: Due to the weight of the Shop Crane, assistance during assembly is recommended.

Step 1) Line up the holes in each mid size Caster Wheel (5) with the holes on the Base (4). One mid size Caster Wheel (5) is to be attached to each side of the Base (4). For each mid size Caster Wheel (5), slide four (4) Bolts (28) up through a Spring Washer (7) and into Base (4).

Line up the holes in each Small Caster (1) with the holes on the Base (4). One Small Caster (1) is to be attached to each side of the Base (4). For each Small Caster (1), slide four (4) Bolts (27) up through a Spring Washer (7), and through Washer (6) and into Base (4).

Step 2)

Slide each Leg (8 & 25) into each of the two slots on top of the Base (4). Insert two Pins (3) through the Base (4) at the junction of each Leg (8 and 25). Attach a Hitch Pin (24) through each of the four (4) Pins (3) to secure together - see Figure 1.

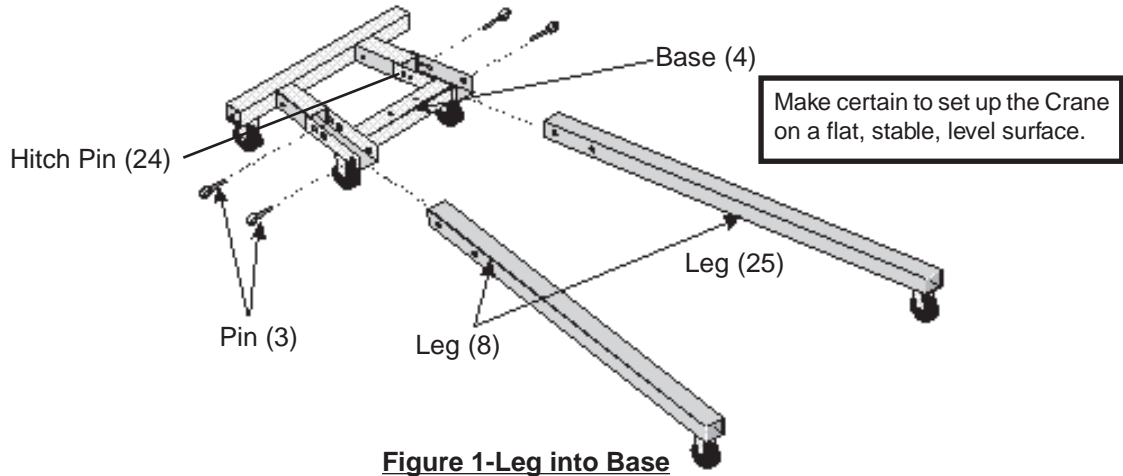

Figure 1-Leg into Base

Step 3)

With the assistance of another person, attach the Support Post (10) to the Base (4). Insert both Bolts (9) down through the bottom bracket of the Support Post (10). Slide on Washers (32), and slide on Spring Washers (33). Tighten Nuts (18) - see Figure 2.

Caution: Be aware of dynamic loading! A sudden start or jerk of the chain and hook may create for a brief instant, an excess load, which may result in damage to the product and/or personal injury.

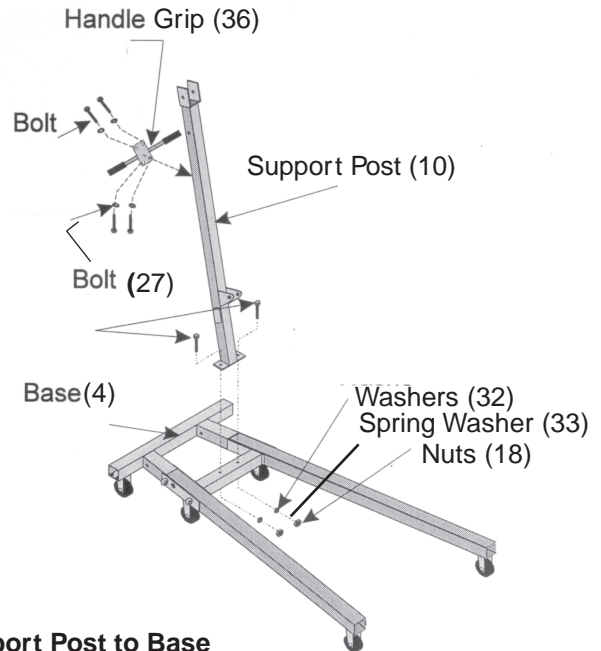
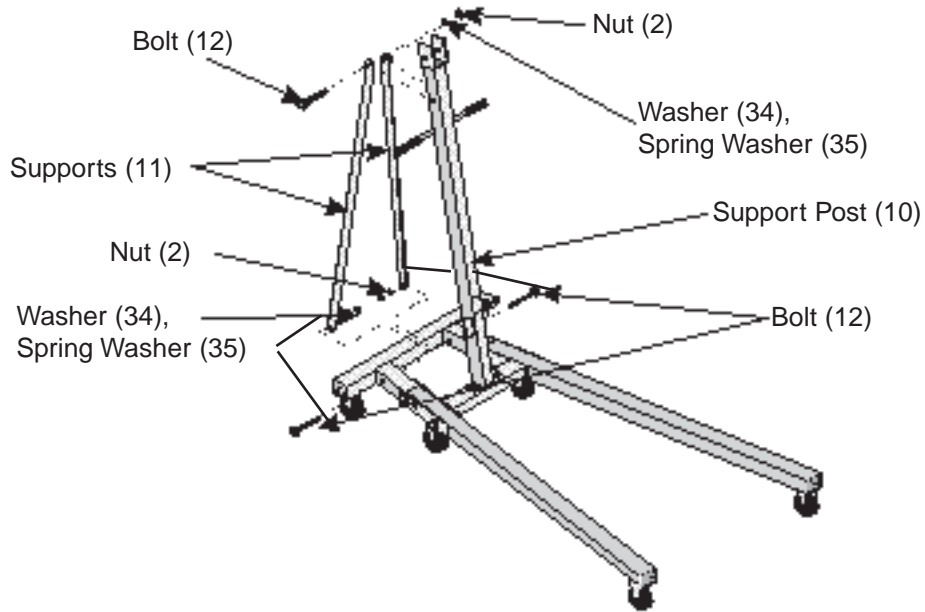

Figure 2-Support Post to Base

Step 4)

Attach both of the Supports (11) to the Base (4), one at each end. For each Support, insert a Bolt (12) through the hole in the bottom of the Support (11), and through the Base (4). Slide on Washers (34), Spring Washers (35) and tighten on Nut (2) - see Figure 3 on following page. Line up the holes at the top of the Support (11) with the second hole down on the Support Post (10). Attach Supports (11) to the Support Post with Bolt (12). Slide on Washer (34) and Spring Washer (35). Tighten on Nut (2).

Figure 3-Supports to Support Post



Step 5) Attach the Handle Grip (36) to the Support Post (10). Slide a Washer (6) and a Spring Washer (7) onto each of four Bolts (27). Insert the Bolt (27) and Washers (6 and 7) through Handle Grip (36) and tighten to Support Post (10) - see Figure 2.

Step 6) Attach the Hydraulic Ram (21) to the bracket located toward the bottom of the Support Post (10) - see Figure 4B below. Insert Bolt (17), then slide on Washer (32) and Spring Washer (33). Tighten on Nut (18). Lean the Hydraulic Ram (21) against the Support Post (10) while installing the Boom (13) in next step.

Step 7) Set the Boom (13) onto the top of the Support Post (10). Insert Bolt (14) through the holes, then slide on Washer (30) and Spring Washer (31). Tighten on Nut (26) - see Figure 4A.

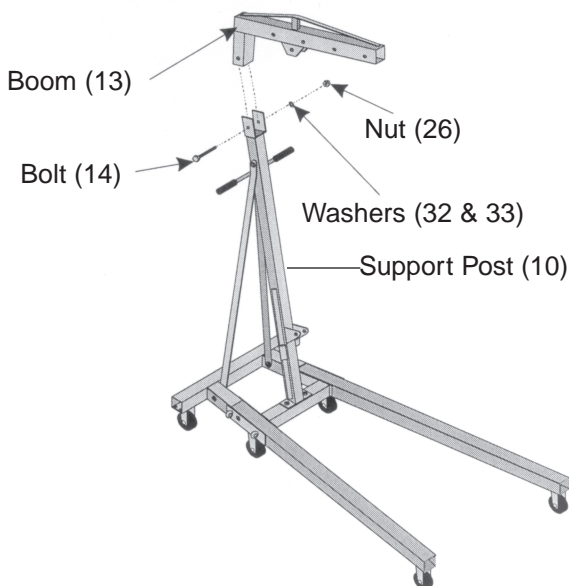

Figure 4A -Assembling the Boom

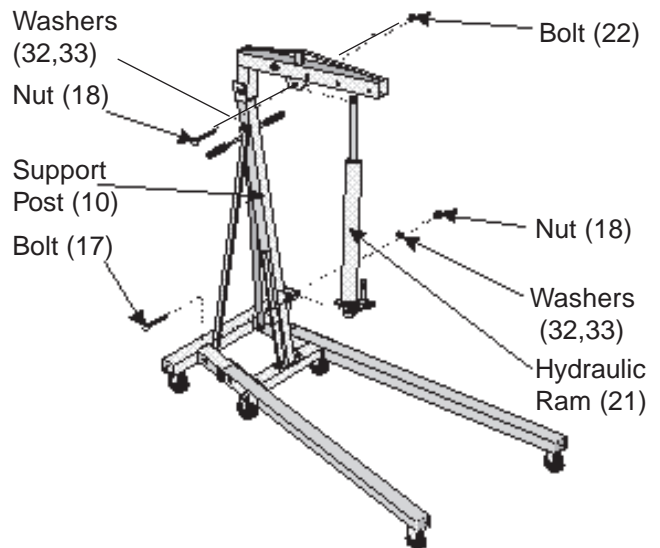

Figure 4B-Attaching the Hydraulic Ram

Step 8) Attach the Hydraulic Ram (21) to the fork near the center of the Boom (13) with Bolt (22), Washer (32) and Spring Washer (33). Tighten into place with Nut (18) - see Figure 4B on the previous page.

Step 9) Slide the Boom Extension (16) into the Boom (13). Note that there are different settings for the load. Secure the Boom Extension (16) at the setting **which exceeds the load** you will be lifting. Insert Bolt (29), Washer (32) and Spring Washer (33) and secure with Nut (18) - see Figure 5.

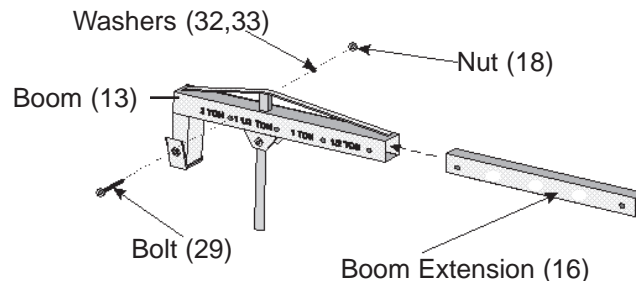

Figure 5-Assembling the Boom Extension

Step 10) Attach the Hook (19a) around the end of the Boom Extension (16) using Bolt (20). Insert Bolt (20) through one side of the Hook, through the Boom Extension (16), and out the other side of the Hook (19a). Slide on Washer (34) and Spring Washer (35). Tighten in place with Nut (2) - see Figure 6.

WARNING:
Never stand under an object that is being lifted by the Shop Crane. Be aware of the possibility of a load slipping off of the Hook. An item that falls from the Crane can cause serious injury.

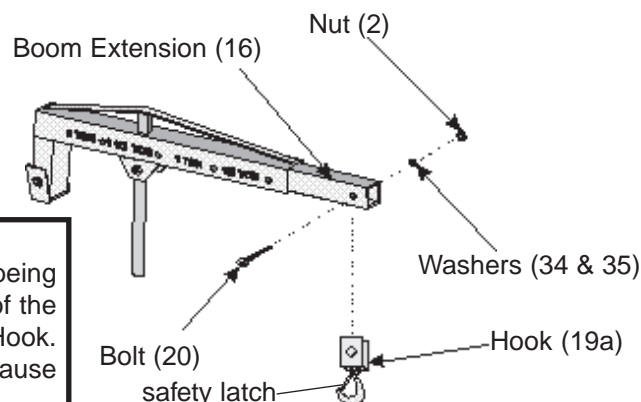

Figure 6-Attaching the Hook

Step 11) Insert the Jack Handle (23) into the socket on the Hydraulic Ram (21).

Operation

Step 1) Set the Boom Extension (16) to a weight limit setting **that exceeds the weight you will be lifting**. Do not exceed the Maximum 2 Ton weight capacity. Insert Bolt (29), Washer (32) and Spring Washer (33) and secure with Nut (18) - see Figure 5.

Step 2) Test the operation of the Shop Crane prior to lifting the load. Make certain that pumping the Handle will raise a load. Verify that all hardware is tight and in good working order.

Step 3) Move the Crane so that the Hook (19) is directly above the item to be lifted. Make certain that the safety latch on the Hook (19) fully closes. Securely attach the Hook (19) to the item. Load must be secure in the Hook (19) with the safety latch fully closed. Make certain that the load is sustained with chains or slings before using the Crane to lift it.

Operation (cont'd)

CAUTION!

Limit movement of the Shop Crane when under load. Always lower the load as low as possible to reduce the center of gravity. ⚠ **DANGER!** If the load is not lowered and is allowed to swing freely, the Shop Crane can tip over.

Step 4) To raise the Boom (13), turn the Hydraulic Ram's release valve fully clockwise. Pump the Handle (23) up and down repeatedly until the item is lifted to the desired height.

Step 5) To lower the Crane, **slowly** turn the release valve counterclockwise.

Folding the Shop Crane

Step 1) Lower the Crane all the way.

Step 2) Remove the front two Pins (3). Leave rear Pins (3) in place.

Step 3) Raise the Legs (8 & 25) until they rest against the Support Post (10).

Step 4) Set the loose Pins (3) into the middle hole in the Base.

Note: When folded up, the Shop Crane can be rolled on the 2 small Casters and 2 mid size Casters.

Troubleshooting Tips

PROBLEM

SOLUTION

Hydraulic Ram will not lift load

- Release valve not closed. Turn valve clockwise.
- Check Hydraulic fluid level
- Pump seal and backup ring defective. Have serviced by a qualified technician.

Will not hold load/ Handle rises

- Discharge ball is not sealing hydraulic system. Hydraulic fluid may be dirty.
- Open Release Valve and then pump the Handle.
- Flush system.

Will not lift to its full height

- Bleeding Instructions:
- Check Hydraulic fluid level.
- Air in Hydraulic system. Open Release valve, pump handle four full strokes to release air.
- Top off with Hydraulic Fluid. Close the oil fill cap. Close Release Valve.

Will not lower completely

- Return Spring broken or linkages binding. Grease pivot shaft; oil all linkages.
- Have qualified technician replace Return Spring

Feels spongy; will not lift smoothly

- Bleeding Instructions:
- Check Hydraulic fluid level.
- Air in Hydraulic system. Open Release valve, pump handle four full strokes to release air.
- Top off with Hydraulic Fluid. Close the oil fill cap. Close Release Valve.

Unpacking

When unpacking your 2 Ton Foldable Shop Crane, check to make sure the following parts are included. If any parts are missing or broken, please call **HARBOR FREIGHT TOOLS** at **1-800-444-3353**.

Parts List

Part	Description	Qty	Part	Description	Qty
1	Small Caster - 2.36" Dia.	2	20	Bolt M14 x 3.34"	1
2	Nut M14	4	21	Hydraulic Ram	1
3	Pin	4	22	Bolt M16 x 3.34" (8.8 Grade)	1
4	Base	1	23	Jack Handle	1
5	Mid Size Caster - 3.54" Dia.	4	24	Hitch Pin	4
6	Washer	12	25	Left Leg	1
7	Spring Washer	28	26	Nut M 18	1
8	Right Leg	1	27	Bolt M8 x .59"	12
9	Bolt M16 x 3.74"	2	28	Bolt M8 x .78"	16
10	Support Post	1	29	Bolt M16 x 3.34"	1
11	Support	2	30	Washer M18	1
12	Bolt M 14 x 4.13"	3	31	Spring Washer M18	1
13	Boom	1	32	Washer M16	5
14	Bolt M18 x 4.13"	1	33	Spring Washer M16	5
15	-unused-		34	Washer M14	4
16	Boom Extension	1	35	Spring Washer M14	4
17	Bolt M16 x 3.74" (8.8 Grade)	1	36	Handle Grip	1
18	Nut M16	5	37	-unused-	
19a	Hook	1			

Note: Some parts are listed and shown for illustration purposes only and are not available individually as replacement parts.

PLEASE READ THE FOLLOWING CAREFULLY

THE MANUFACTURER AND/OR DISTRIBUTOR HAS PROVIDED THE PARTS DIAGRAM IN THIS MANUAL AS A REFERENCE TOOL ONLY. NEITHER THE MANUFACTURER NOR DISTRIBUTOR MAKES ANY REPRESENTATION OR WARRANTY OF ANY KIND TO THE BUYER THAT HE OR SHE IS QUALIFIED TO MAKE ANY REPAIRS TO THE PRODUCT OR THAT HE OR SHE IS QUALIFIED TO REPLACE ANY PARTS OF THE PRODUCT. IN FACT, THE MANUFACTURER AND/OR DISTRIBUTOR EXPRESSLY STATES THAT ALL REPAIRS AND PARTS REPLACEMENTS SHOULD BE UNDERTAKEN BY CERTIFIED AND LICENSED TECHNICIANS AND NOT BY THE BUYER. THE BUYER ASSUMES ALL RISK AND LIABILITY ARISING OUT OF HIS OR HER REPAIRS TO THE ORIGINAL PRODUCT OR REPLACEMENT PARTS THERETO, OR ARISING OUT OF HIS OR HER INSTALLATION OF REPLACEMENT PARTS THERETO.

Parts/Assembly Diagram

