

## Apartment House Intercoms

MODELS: 478-76 & 478-77

### Model 478-76

Use as a replacement control amplifier for the former Direct-A-Com 1 System, Model 476 amplifier:

1. Install the Model 467 Postal/Main Door Timer module as described in the instructions packaged with the unit.
2. Wire the amplifier-adaptor to the system as shown in the wiring diagram.

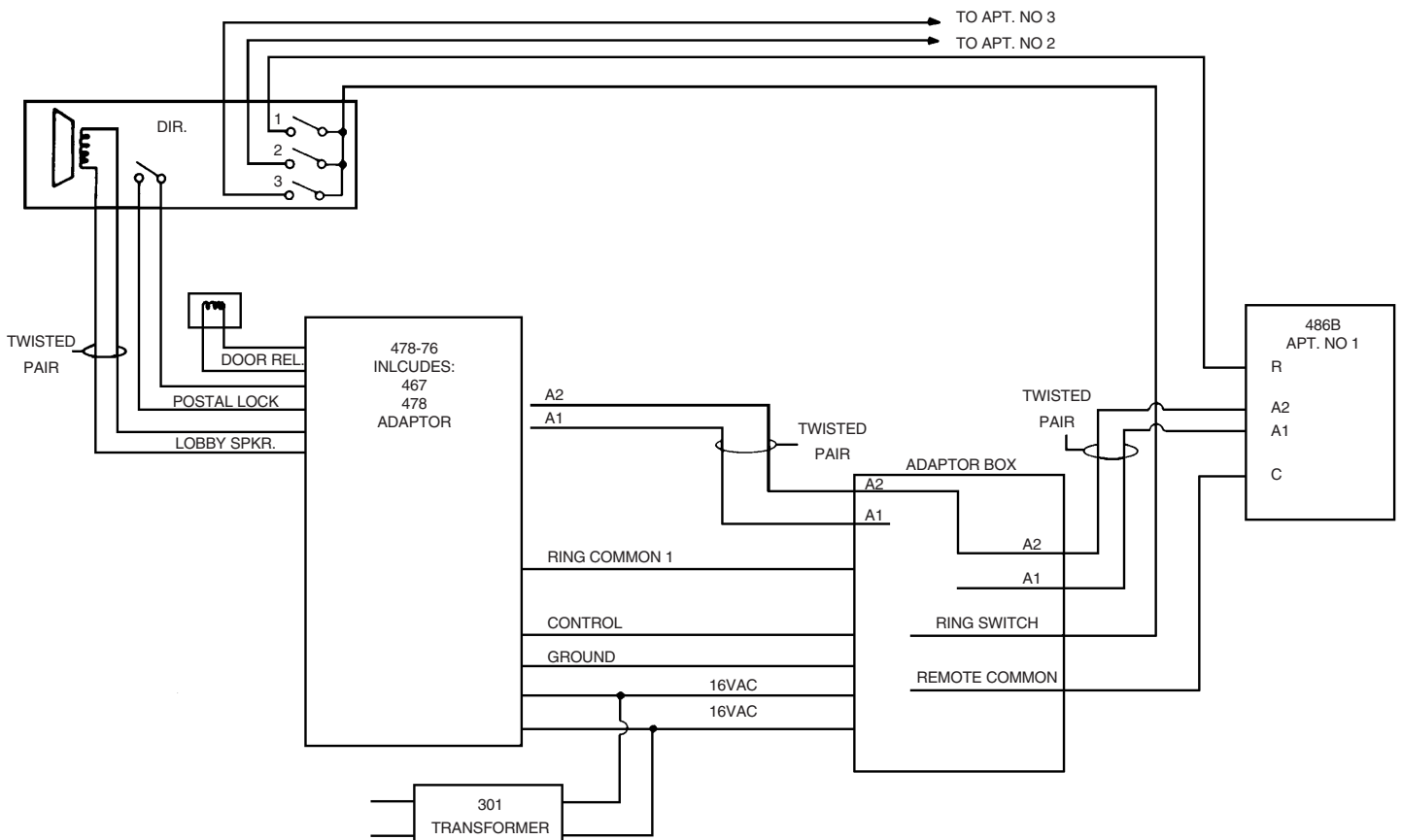

(Please see other side for Model 478-77)

# Model 478-77

Use as a replacement control amplifier for the former Direct-A-Com 1 with two entry auto-call transfer, Model 477 amplifier:

1. Install the Model 467 Postal/Main Door Timer module and the Model 469 Auto-Call Transfer module as described in the instructions packaged with each unit.
2. Wire the amplifier-adapter to the system as shown in the wiring diagram.

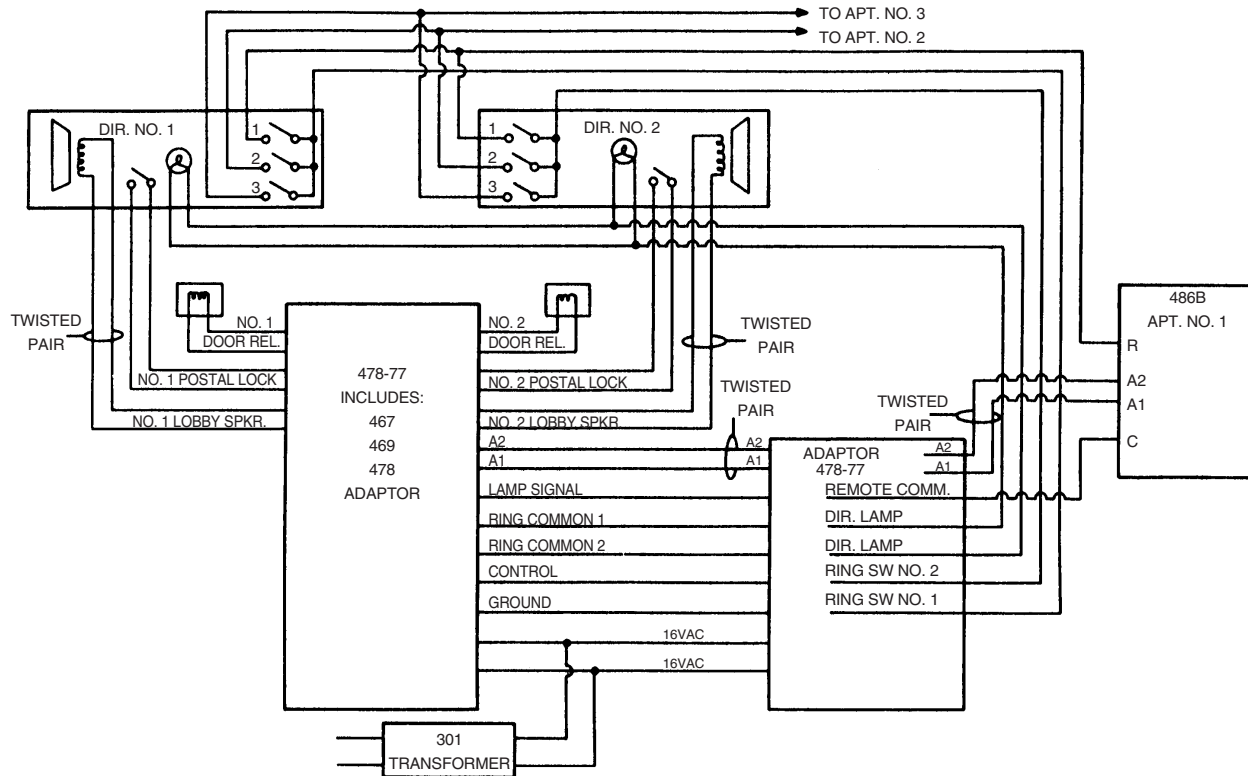

## NuTone®

### Two Year Limited Warranty

**WARRANTY OWNER:** NuTone warrants to the original consumer purchaser of its products that such products will be free from defects in materials or workmanship for a period of two (2) years from the date of original purchase. **THERE ARE NO OTHER WARRANTIES, EXPRESS OR IMPLIED, INCLUDING, BUT NOT LIMITED TO, IMPLIED WARRANTIES OF MERCHANTABILITY OR FITNESS FOR A PARTICULAR PURPOSE.**

**During this two year period,** NuTone will, at its option, repair or replace, without charge, any product or part which is found to be defective under normal use and service. **THIS WARRANTY DOES NOT EXTEND TO FLUORESCENT LAMP STARTERS OR TUBES, FILTERS, DUCT, ROOF CAPS, WALL CAPS AND OTHER ACCESSORIES FOR DUCTING.** This warranty does not cover (a) normal maintenance and service or (b) any products or parts which have been subject to misuse, negligence, accident, improper maintenance or repair (other than by NuTone), faulty installation or installation contrary to recommended installation instructions.

The duration of any implied warranty is limited to the one year period as specified for the express warranty. Some states do not allow limitation on how long an implied warranty lasts, so the above limitation may not apply to you.

**NUTONE'S OBLIGATION TO REPAIR OR REPLACE, AT NUTONE'S OPTION, SHALL BE THE PURCHASER'S SOLE AND EXCLUSIVE REMEDY UNDER THIS WARRANTY. NUTONE SHALL NOT BE LIABLE FOR INCIDENTAL, CONSEQUENTIAL OR SPECIAL DAMAGES ARISING OUT OF OR IN CONNECTION WITH PRODUCT USE OR PERFORMANCE.** Some states do not allow the exclusion or limitation of incidental or consequential damages, so the above limitation or exclusion may not apply to you. This warranty gives you specific legal rights, and you may also have other rights, which vary from state to state. This warranty supersedes all prior warranties.

**WARRANTY SERVICE:** To qualify for warranty service, you must (a) notify NuTone at the address stated below or telephone 1/800-543-8687, (b) give the model number and part identification and (c) describe the nature of any defect in the product or part. At the time of requesting warranty service, you must present evidence of the original purchase date.

Date of Installation \_\_\_\_\_

Builder or Installer \_\_\_\_\_

Model No. and Product Description \_\_\_\_\_

#### IF YOU NEED ASSISTANCE OR SERVICE:

For the location of your nearest NuTone Independent Authorized Service Center:  
Residents of the contiguous United States Dial Free 1-800-543-8687

Please be prepared to provide:

Product model number • Date and Proof of purchase • The nature of the difficulty

Residents of Alaska or Hawaii should write to: NuTone Inc. Attn: Department of National Field Service, 4820 Red Bank Road, Cincinnati Ohio 45227-1599.

Residents of Canada should write to: Broan-NuTone Canada, 1140 Tristar Drive, Mississauga, Ontario, Canada L5T 1H9.

Rev. 03/2001

Product specifications subject to change without notice.

4820 Red Bank Road, Cincinnati, OH 45227  
Printed in U.S.A., Rev. 10/03, Part No. 48713