



kitchen think

## **Instructions for Installation and Use**

**Electric Hob  
Model E600, E6002**

To the Installer

Before installation fill in the product details on the back cover this book.  
The information can be found on the rating plate.

To the User

You must read the instructions prior to installing and using the appliance and  
then retain them for future reference.



# CONTENTS

Introduction	4
For Your Safety	5
Know your Hob	6
How to use your Hob	6
Practical Advice	7
Care and Cleaning	8
Troubleshooting	8
Installation - Model E600	9
Electrical Connection - Model E600	10
Installation - Model E6002	11
Electrical Connection - Model E6002	12
After Sales Service	14
Hotpoint Guarantee	15
Key Contacts	Back Cover

## Retention of this Instruction Book

This Instruction Book must be kept handy for reference as it contains important details on the safe and proper use of the appliance.

If you sell or pass the appliance to someone else, or move house and leave it behind, make sure this Book is also provided so the new owner can become familiar with the appliance and safety warnings.

If the Book is lost or damaged a copy may be obtained from:  
GDA LTD., Morley Way, Peterborough, PE2 9JB

# Introduction

Your new hob is guaranteed\* and will give lasting service. This guarantee is only applicable if the appliance has been installed in accordance with the installation instructions detailed in this booklet.

To help make best use of your cooking equipment, please read this booklet carefully.

The hob is designed specifically for domestic use and responsibility will not be accepted for use in any other installation.

When first using the hob ensure that the room is well ventilated (eg. open a window or use an extractor fan) and that persons who may be sensitive to the odour avoid any fumes. It is suggested that any pets be removed from the room until the odour has ceased. This odour is due to temporary finish on elements.

**\* The guarantee is subject to the provisions that the appliance:**

- (a) Has been used solely in accordance with this booklet.**
- (b) Has been properly connected to a suitable supply voltage as stated on the rating plate, attached to the appliance.**
- (c) Has not been subjected to misuse or accident or been modified or repaired by any person other than the manufacturers authorised employee or agent.**
- (d) Has been correctly installed.**



**This appliance conforms with the following European Economic Community directives**

- 73/23/EEC of 19/02/73 (Low Voltage) and subsequent modifications.
- 89/336/EEC of 03/05/89 (Electromagnetic Compatibility) and subsequent modifications.
- 93/68/EEC of 22/07/93 and subsequent modifications.

# For Your Safety

**When used properly your appliance is completely safe but as with any electrical product there are certain precautions that must be observed.**

**PLEASE READ THE BELOW PRECAUTIONS BEFORE USING YOUR APPLIANCE.**

To maintain the efficiency and safety of this appliance, we recommend you do the following:

- only call the Service Centres authorised by the manufacturer.
- always use genuine spare parts.

## **ALWAYS:**

- make sure you remove all packaging and dispose of safely.
- check the soundness of the appliance after it has been unpacked.
- make sure you understand the controls before using the appliance.
- keep children away from the appliance during use.
- take care to avoid heat/steam burns when operating the controls.
- make sure the controls are turned off when you have finished cooking and when not in use.
- disconnect from the power supply, and allow to cool, before cleaning or performing maintenance.
- disconnect from the power supply should any glass panel (if fitted) crack or shatter and then **DO NOT USE** the hob until it is repaired.
- refer servicing to a qualified appliance service engineer.
- keep the hob clean as a build up of grease or fat from cooking can cause a fire.
- follow the basic principles of food handling and hygiene to prevent the possibility of bacterial growth.
- dry food thoroughly before frying and lower it slowly into the hot oil or fat. Frozen food in particular, will cause frothing and spitting if added too quickly.
- keep outside of pans clean and free from streaks of oil or fat.
- place pans centrally over the hotplates making sure handles are kept away from the edge of the hob and cannot be heated by other hotplates.
- keep any ventilation slots clear of obstructions.

## **NEVER:**

- attempt to install or repair the appliance without the assistance of qualified personnel.
- store items above the appliance that children may attempt to reach.
- heat up unopened food containers, as pressure can build up causing the container to burst.
- use the appliance to heat up anything other than food.
- use the appliance as a room heater.
- dry any items on the hob.
- install the appliance next to curtains or other soft furnishings.
- allow children to play with or tamper with the controls.
- leave children unsupervised where cooking appliances are installed as all the cooking surfaces get hot during and after use.
- store chemicals, foodstuffs or pressurised containers in or on the appliance, or in cabinets immediately above or next to the appliance.
- use flammable or plastic items on or near the hob.
- use adapters, multiple sockets and/or extension leads.
- fill a deep fat frying pan more than 1/3 full of oil, or use a lid. **DO NOT LEAVE UNATTENDED WHILE COOKING.**
- fry too much food at a time, especially frozen food. This only lowers the temperature or the oil or fat too much, resulting in greasy food.
- pull on the appliance or the supply cable to unplug it from the electrical outlet.
- allow power cables of other appliances to come into contact with hot parts of this appliance.
- expose the appliance to atmospheric agents, such as rain or sunlight.
- operate the appliance with wet hands.
- operate the appliance when barefoot.
- allow anyone to sit or stand on any part of the appliance.
- use misshapen pans which may be unstable.
- use fish kettles or large preserving pans across two hotplates.
- gaze at halogen elements when they are in operation.
- leave anything on the hob surface when unattended and not in use.

## **SAFETY ADVICE**

**IMPORTANT** - As with any cooking appliance there could be some fire risk attached to the heating of oil, particularly for deep fat frying. Cooking utensils containing oil must not be left unattended (eg. to answer the telephone) on or in close proximity to the cooking areas.

### **IN THE EVENT OF A CHIP PAN OR ANY OTHER PAN FIRE:**

1. Turn off the hotplates.
2. Cover the pan with a fire blanket or damp cloth, this will smother the flames and extinguish the fire.
3. Leave the pan to cool for at least 60 minutes before moving it. Injuries are often caused by picking up a hot pan and rushing outside with it.

**NEVER USE A FIRE EXTINGUISHER TO PUT OUT A PAN FIRE** as the force of the extinguisher is likely to tip the pan over. Never use water to extinguish oil or fat fires.

# Know your Hob

- A Cooking areas
- B "ON" indicator light
- C Control Knobs
- D Residual heat indicator light

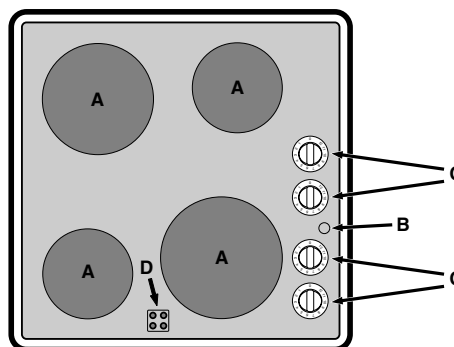

## How To Use Your Hob

### Guide to using the hotplates:

**The heating elements** are circular in shape and turn red in colour 20-30 seconds after they have been turned on.

### Mixed halogen zones.

The hob utilises heating elements which are made up of two halogen lamps and a circular heating element. This combination provides ideal heat distribution across the entire surface of the cooking area. Halogen lamps provide an instantaneous emission of a large quantity of light and heat, which means they are:

- a rapid source of heat similar to that provided by gas burners;
- an equally rapid elimination of the heat source.

Halogen lamps are extremely easy to use and their operation is similar to that of other heating elements.

### The control knobs

Each cooking area is equipped with a control knob to regulate the temperature at any time from a minimum of 1 to a maximum of 12. The table gives information on the settings indicated on the knobs and the corresponding, recommended uses.

Setting	Automatic plate
0	Off
1	For melting butter, chocolate
2	For heating liquids
3	
4	For creams and sauces
5	
6	For cooking at boiling temperature
7	
8	For roasts
9	
10	For big boiled dishes
11	
12	For frying

### The "ON" indicator light (B)

This light comes on when one of the heating elements has been turned on.

### Residual heat indicator light (D)

This light indicates that the temperature of one or more cooking areas is above 60°C, even though the elements have been turned off. Some models come equipped with four such indicator lights, one for each of the four cooking areas.

## Practical Advice

### Choice of utensils:

Every Electric Hob deserves the right choice of utensils. We recommend for optimum performance the use of good quality utensils.

### PANS SHOULD NOT:

- Be concave (bowed in).
- Be convex (bowed out).
- Be rimmed.
- Be deeply ridged.

### BUT SHOULD BE ESSENTIALLY FLAT

#### Always

- Use good quality flat-based cookware on all electric heat sources.
- Place pans centrally on the hotplate.
- Ensure pans have clean, dry bases before use.
- Ensure pans match the size of the heating area.
- Remember good quality pans retain heat well, so generally only a low or medium heat is necessary.
- Ensure pan handles are positioned safely and away from heat sources.
- Lift pans, do not drag.
- Use pan lids, except when frying.
- Deal with spillage immediately, but with care.

#### Never

- Use gauze, metal pan diffusers, asbestos mats and stands eg. wok stands - they can cause overheating.
- Use utensils with skirts or rims eg. buckets and some kettles.
- Use badly dented or distorted pans.
- Leave an element on when not cooking.
- Cook food directly on the hotplate.
- Drag or slide utensils across the hotplate.
- Place large preserving pans or fish kettles across two hotplates.
- Place plastic vessels or utensils on a hot hob.
- Use the hob as an area for storage.

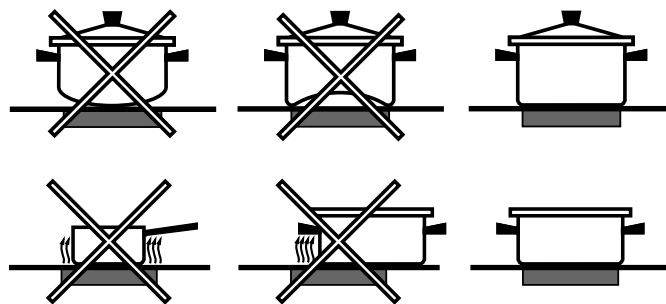

### The Best Combinations:

Below is a general guide to the types of pan suitable for different types of hobs and cookers. Remember pans should be good quality with smooth, flat bases. For any further information refer to the manufacturers instructions.

	Suitable
Aluminium	✓
Stainless Steel with single layer copper base	✓
Stainless Steel with sandwich base of aluminium and stainless or aluminium and copper	✓
Enamelled Steel	✓
Enamelled Aluminium	✓
Enamelled based cast iron	✓ With Care
Cast iron	✗
Copper	✗
Toughened glass or ceramic / glass / pottery	✗ Not Recommended
Mild steel, Ferro-magnetic or stainless with a magnetic sandwich base	✓

### Hob Spillages:

1. Always clean up any spillage immediately with a clean cloth or a paper towel to avoid any unnecessary damage to the hob. Extreme care should be taken to avoid steam burns and hot surfaces when cleaning spillage from the hob.

2. When cooking food that contains sugar (most food) or syrup, use a utensil which is large enough to prevent boil over or spillage. **Sugar spillage will permanently damage the hob and therefore should be cleaned off with care immediately.** If sugar spillage has occurred, remove it as long as it is still hot, with a metal safety razor scraper. This will avoid any damage.

NEVER let it cool before removing.

3. Always ensure that the base of the utensil is dry before placing on the hob.

**IMPORTANT:** Extreme caution should be used when cleaning the hot hob!

## Care and Cleaning

Before cleaning or performing maintenance on your hob, disconnect it from the power supply. Check that all controls are in the OFF position before reconnecting.

**NEVER USE: Washing powder, harsh abrasive, scouring pads, aerosol cleaners or oven chemical cleaners of any kind.**

### Cleaning materials to avoid

- Household abrasive powders, eg. Vim.
- Oven chemical cleaners, aerosols and oven pads - Caustic cleaners such as these will etch the surface and attack the metal frame.
- Bath and sink cleaners may mark the surface.

### The Ceramic Hob

To reduce the amount of cleaning always ensure that the hob and cooking utensils are clean and dry before use. Regular use of cleaner conditioner is recommended for proper care and protection of the hob surface. Apply conditioner before using the hob for the first time. It contains a mild cleaning agent, so that subsequent cleaning applications may clean off soil and apply a protective film at the same time. For stubborn stains or heavy soiling use any of the following materials, and finish off with conditioner:

1. Cif, non-scratch scouring cream.
2. Liquid Gumption Kitchen Cleanser.
3. Special Powder Cleanser.

### Stainless Steel

Wipe with a cloth wrung out in warm soapy water followed by a wipe with a cloth wrung out in clean water and then dry with a soft clean cloth.

**Powder Cleanser** - Mineral deposits that are present in hard water and some foods may cause discolouration, that appear in the form of grey or brown stains. The stains sometimes appear to be in or under the glass surface. If there are any persistent stains after using any of the other recommended cleaning materials, powder cleanser may be applied, following the manufacturer's instructions. DO NOT use abrasive cleaners or powder cleanser on the painted metal framework. Pans with aluminium bases should be lifted rather than dragged across the hob surface. This will avoid metal rubbing off the pan onto the glass. Such marks are easily removed by the powder cleanser provided they are not subsequently baked on for long periods at high temperatures.

**Cleaner Conditioner** - Regular use of the conditioner will make the surface easier to clean thus ensuring that years of heavy abrasive cleaning do not progressively dull the surface. If the hob is scratched through accident or misuse, soil that collects will appear as fine brown lines; these are not fully removable but can be made less obvious by the daily use of cleaner conditioner. Cooking performance is in no way affected by scratches on the surface.

### Control Knobs

Wipe over the knobs with a soft cloth wrung out in warm soapy water or mild non-abrasive. Then, after wiping with a cloth wrung out in clear water, dry with a soft clean cloth.

### Painted Metal Surround Trim

Wipe over with a cloth wrung out in warm soapy water only. DO NOT USE ABRASIVES.

## Troubleshooting

Before calling service for assistance, check through the following list, there may be nothing wrong.

### Nothing works.

Check to make sure that:

- the mains wall switch is switched on.  
If a control is on, the corresponding residual heat indicator light will come on.

### Hotplates are slow to boil or will not simmer.

Check to make sure that:

- Your pans conform with the recommendations detailed in this book.

If, despite all of these checks, the hob does not function properly and the problem persists, call Hotpoint Service (see KEY CONTACTS, back page), informing them of:

- The type of problem.
- The abbreviation used to identify the model (Mod. ...) as indicated on the warranty.

### IMPORTANT:

Never call upon technicians not authorized by the manufacturer, and refuse to accept spare parts that are not original.



# Installation - Model E600

These instructions are intended for the qualified technician installing the appliance in order to insure that the installation, adjustments and maintenance procedures are performed correctly and comply with the regulations currently in effect. **Important: the hob must be disconnected from the power supply before making any adjustments or performing any maintenance, etc.**

## Installing built-in hobs

The hob has a type X protection rating against overheating in compliance with regulation CEI 335-2-6. Therefore, the hob cannot be installed alongside of cabinets which are higher than the surface of the hob itself. The following precautionary measures should be observed in order to ensure proper installation:

- Hoods must be installed in compliance with the required specifications contained in the instruction manual for the hood itself.
- The built-in ceramic glass top can be installed on any counter top as long as it is 600 mm or more in width and resistant to temperatures of up to 100°C. The dimensions and the position of the hole are shown in fig..

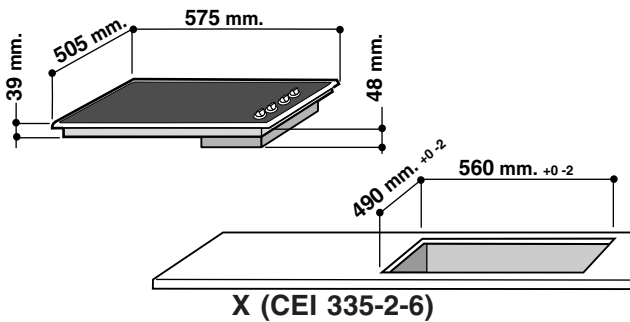

These measurements must absolutely be observed in so far as improper installation can cause the surrounding surface areas to overheat. It is recommended that the hob be installed at a distance of at least 40 mm from the back wall or other vertical surfaces to ensure that the air circulates properly over the cooking area and to avoid overheating the surrounding surfaces. A seal or gasket is provided with the hob; make sure that it adheres properly to the bottom part of the frame of the hob.

The seal must fit properly around the entire hob frame and especially along the corners in order to create a seal between the counter top and the cooktop itself so as to prevent spills or splashes from leaking into the cabinet below. Fasten the 4 hooks supplied into the slots as shown in Fig.;

### Fastening diagram for the hooks

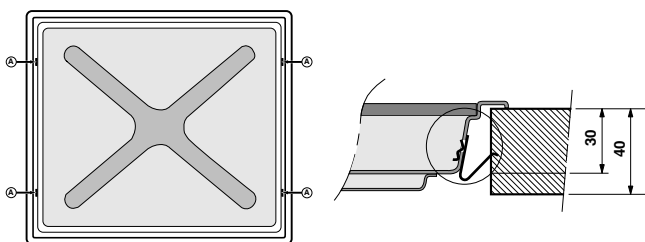

Fastening positions

Hook placement for 40 and 30 mm tops

Insert the hob into the hole, pressing firmly around the frame to make it adhere to the counter top.

**Important:** The surface where the hob is installed must be perfectly flat. Deformations caused by improper installation may affect the characteristics of the hob, and, therefore, its performance.

- If a wooden panel is installed beneath the hob for insulation purposes, it must be positioned at least 20 mm from the bottom part of the hob itself.

**Note:** If the hob is installed above a built-in oven, it is preferable that the oven be installed in such a way that it is set on two strips of wood; if, on the other hand, the oven is installed on a continuous base, there must be an opening in the back of at least 45 x 560 mm.

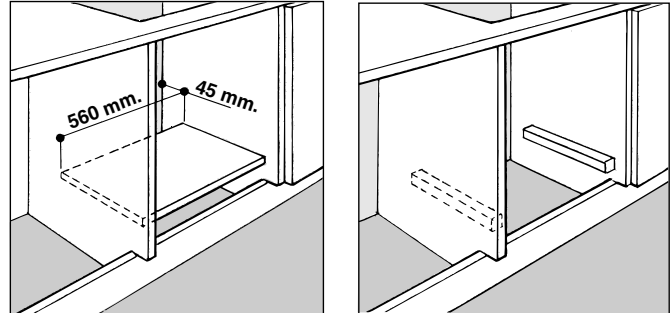

If the hob is installed above a built-in oven equipped with a forced air cooling system, air intake and exhaust slots must be provided to ensure that the air circulates properly within the cabinet. Figures provide illustration of possible installation solutions.

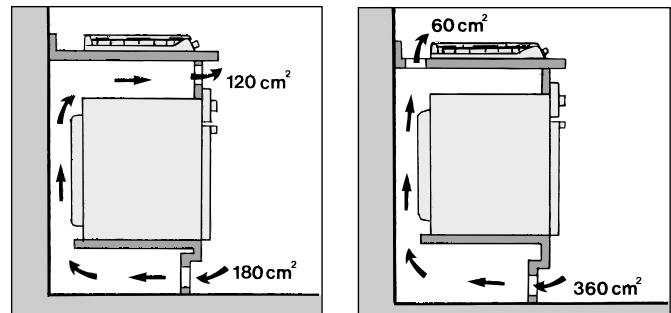

# Electrical Connection - Model E600

## Electrical Connection

THIS APPLIANCE MUST BE EARTHED.

The installation procedure must be carried out by a qualified electrician.

The electrical safety of this appliance is guaranteed only if the appliance is correctly earthed in compliance with the standards of electrical safety.

The manufacturer can under no circumstances be considered responsible for any damage that might occur due to incorrect earthing of the hob.

The electric hob is not supplied with a power supply chord because the type of chord used depends on the type of electrical connection (see the following connection diagram).

Open the terminal box following the instructions illustrated in the diagram below:

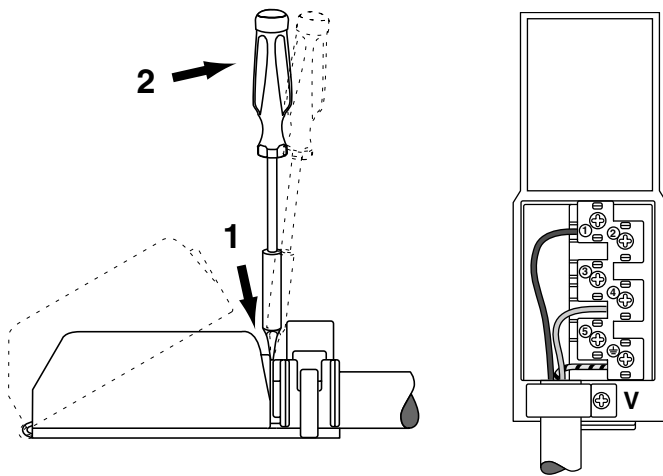

To connect the supply cord, proceed as follows:

- Loosen the screws on the wire clamp "V", as well as the screws for the contacts.
- Insert the wires beneath the contact screws, as shown in the diagram and tighten them.
- Fasten the cord with the appropriate wire clamp and close the cover.

Electrical Connections:

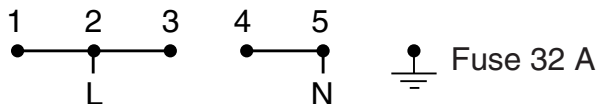

## Voltage and frequency of power supply:

230-240V

50-60Hz

5700W

## Connecting the supply cord to the electrical mains:

The hob must be connected to a double pole mains switch which must be installed between the appliance and the mains.. The double pole mains switch must have a minimum of 3mm of space between the contacts, be sized to the load and comply with current regulations (the switch must not be able to disconnect the earth conductor).

The supply cord should conform to BS6004 conductor size 4mm<sup>2</sup> and must be positioned so that no part of it reaches a temperature of 50°C higher than room temperature.

Before making the connection, make sure that:

- the limiter switch and the residual wiring can support the appliance load (see the rating plate).
- the mains system is properly earthed in compliance with current regulations and provisions.
- there is easy access to the socket or the double pole mains switch after the appliance is installed.

## IMPORTANT:

If the hob is installed above a built-in oven, the electrical connection for the hob must be independent of that for the oven, both for safety reasons and to facilitate the removal of the oven for maintenance, repair etc.

# Installation - Model E6002

These instructions are intended for the qualified technician installing the appliance in order to insure that the installation, adjustments and maintenance procedures are performed correctly and comply with the regulations currently in effect. **Important: the hob must be disconnected from the power supply before making any adjustments or performing any maintenance, etc.**

## Installing built-in hobs

The hob has a type X protection rating against overheating in compliance with regulation CEI 335-2-6. Therefore, the hob cannot be installed alongside of cabinets which are higher than the surface of the hob itself. The following precautionary measures should be observed in order to ensure proper installation:

- Hoods must be installed in compliance with the required specifications contained in the instruction manual for the hood itself.
- The built-in ceramic glass top can be installed on any counter top as long as it is 600 mm or more in width and resistant to temperatures of up to 100°C. The dimensions and the position of the hole are shown in fig..

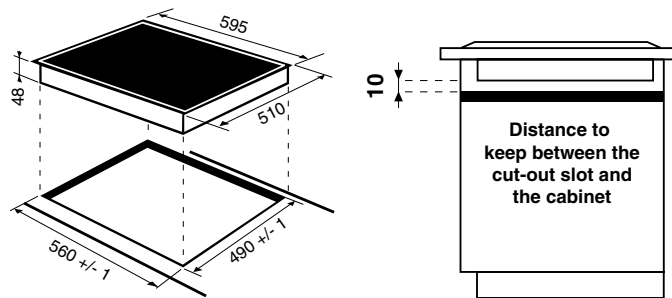

**X (CEI 335-2-6)**

These measurements must absolutely be observed in so far as improper installation can cause the surrounding surface areas to overheat. It is recommended that the hob be installed at a distance of at least 40 mm from the back wall or other vertical surfaces to ensure that the air circulates properly over the cooking area and to avoid overheating the surrounding surfaces. A seal or gasket is provided with the hob; make sure that it adheres properly to the bottom part of the frame of the hob. The seal must fit properly around the entire hob frame and especially along the corners in order to create a seal between the counter top and the hob itself so as to prevent spills or splashes from leaking into the cabinet below.

### Very important

It is essential to install the hob on a totally flat surface. Any damage caused by incorrect fitting may alter the characteristics or impair performance. Insert the hob into the hole, pressing firmly around the frame to make it adhere to the counter top.

**Make certain that the seal around the outside edge of the hob is correctly installed in order to avoid any leakage into the cabinetry below.**

The four securing springs are held in place by 4 Torx screws. To remove the hob unit from its housing, undo the 2 Torx screws at the front, then the 2 Torx screws at the rear. **The 4 screws should be accessible at all times for this purpose.**

REAR SPRING ASSEMBLY

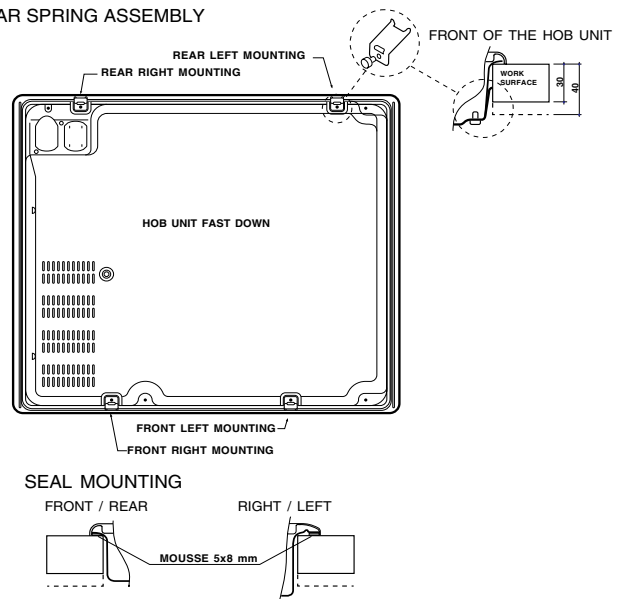

- If a wooden panel is installed beneath the hob for insulation purposes, it must be positioned at least 20 mm from the bottom part of the hob itself.

**Note:** If the hob is installed above a built-in oven, it is preferable that the oven be installed in such a way that it is set on two strips of wood; if, on the other hand, the oven is installed on a continuous base, there must be an opening in the back of at least 45 x 560 mm.

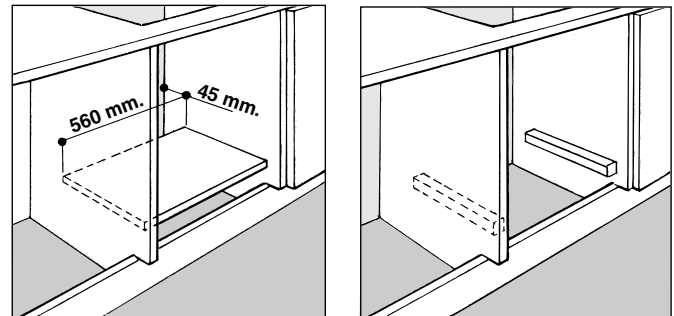

If the hob is installed above a built-in oven **not** equipped with a forced air cooling system, air intake and exhaust slots must be provided to ensure that the air circulates properly within the cabinet. Figures provide illustration of possible installation solutions.

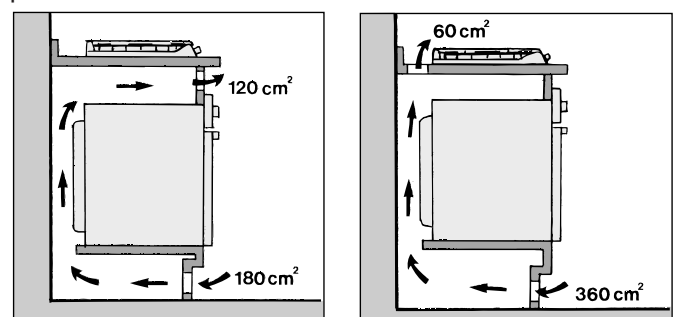

# Electrical Connection - Model E6002

## Electrical Connection

THIS APPLIANCE MUST BE EARTHED.

The installation procedure must be carried out by a qualified electrician.

The electrical safety of this appliance is guaranteed only if the appliance is correctly earthed in compliance with the standards of electrical safety.

The manufacturer can under no circumstances be considered responsible for any damage that might occur due to incorrect earthing of the hob.

## IMPORTANT POINTS:

Your hob is supplied with a special connection cable.

If ever the cable is damaged it should be replaced by an authorised service engineer only.

Disconnect the hob from the electrical supply before any work is carried out.

## To connect the supply cord, proceed as follows:

- Loosen the screws on the wire clamp "V", as well as the screws for the contacts.

- Insert the wires beneath the contact screws, as shown in the diagram and tighten them.

- Fasten the cord with the appropriate wire clamp and close the cover.

Electrical Connections:

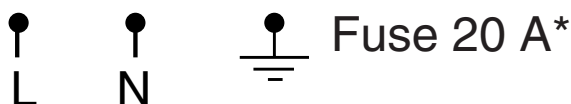

\* Application of the simultaneity coefficient in compliance with standard EN 335-2-6

Y-type connection in compliance with standard

EN 335-2-6

## Voltage and frequency of power supply:

230-240V

50-60Hz

6500W

## Connecting the supply cord to the electrical mains:

The hob must be connected to a double pole mains switch which must be installed between the appliance and the mains. The double pole mains switch must have a minimum of 3mm of space between the contacts, be sized to the load and comply with current regulations (the switch must not be able to disconnect the earth conductor).

The supply cord should conform to BS6004 conductor size 4mm<sup>2</sup> and must be positioned so that no part of it reaches a temperature of 50°C higher than room temperature.

Before making the connection, make sure that:

- the limiter switch and the residual wiring can support the appliance load (see the rating plate).
- the mains system is properly earthed in compliance with current regulations and provisions.
- there is easy access to the socket or the double pole mains switch after the appliance is installed.

## IMPORTANT:

If the hob is installed above a built-in oven, the electrical connection for the hob must be independent of that for the oven, both for safety reasons and to facilitate the removal of the oven for maintenance, repair etc.





## After Sales Service

**"No company is better positioned to offer an after sales service on a Hotpoint appliance than us - the manufacturer"**

As part of our commitment to you, all Hotpoint appliances have the added benefit of a fully inclusive parts and labour guarantee for the first 12 months. In addition to this you also have the advantage of **free replacement parts for the first 5 years** when fitted by a Hotpoint engineer. When the 12 months parts and labour guarantee expires we offer the following after sales service options:

### **Repair Service and Information Help Desk**

UK: 08709 066066

[www.theservicecentre.co.uk](http://www.theservicecentre.co.uk)

Republic of Ireland: 1850 302 200

Note: Our operators will require the Model number and the Serial number of your appliance

Available 364 days a year with a fast, effective and value for money service. We have the largest white goods repair service in the UK with over 1200 of our own fully trained engineers. All repairs include a parts and labour guarantee for 12 months from the date of the repair.

If you require any information or have any questions about your appliance, our operators are on hand with help and advice.

All this ensures that you will receive the best available after sales service possible.

### **Extended Warranties**

UK: 08709 088 088

[www.theservicecentre.co.uk](http://www.theservicecentre.co.uk)

Republic of Ireland: 1850 502 200

Whether you have just one or a number of Hotpoint appliances in your kitchen, we offer two service cover plans to give you total peace of mind.

- ◆ Repair Protection Plan - FREE service repairs for a single Hotpoint appliance during the period of cover.
- ◆ Kitchen Cover - FREE service repairs for all your Hotpoint appliances less than 8 years old.

### **Genuine Parts and Accessories** UK: 08709 077 077

[www.theservicecentre.co.uk](http://www.theservicecentre.co.uk)

Republic of Ireland: (01) 842 6836

A wide range of genuine parts and accessories are available from our hotline or through our web site.

**Genuine parts and accessories, extended warranties and service repairs are all available on our web-site at:**



[www.theservicecentre.co.uk](http://www.theservicecentre.co.uk)



## Guarantee

### "Satisfaction guaranteed or your money back"

We give you a unique 'satisfaction guaranteed' promise - **valid for 90 days** - after you have purchased your Hotpoint appliance. If there is a technical problem simply call Hotpoint Repair service or visit our web-site at [www.theservicecentre.co.uk](http://www.theservicecentre.co.uk) and where necessary, we will arrange for an engineer to call. If the technical problem is not resolved under this guarantee, **we will replace your machine or, if you prefer, give you your money back.**

All Hotpoint appliances carry a fully inclusive 12 month parts and labour guarantee as well as free replacement parts for the first 5 years (except microwaves, selected integrated appliances and cooker hoods, which have a one year guarantee) provided that they are fitted by a Hotpoint engineer.

### Guarantee terms and conditions

Your guarantee is only applicable in the United Kingdom or Republic of Ireland and is subject to the following provisions that your appliance:

- Has been installed and used correctly in accordance with this instruction booklet.
- Has been used solely for domestic purposes and is located on domestic premises (ie. not for commercial or trade use).
- Has been properly connected to a suitable electrical supply voltage as stated on the appliance rating plate.
- Has not been subject to misuse, accident, modified or repaired by anyone other than one of our own service engineers.



For pre purchase information on any other Hotpoint product call: 08701 50 60 70  
or visit: [www.hotpoint.co.uk](http://www.hotpoint.co.uk)



## Recycling & Disposal Information

As part of Hotpoint's continued commitment to helping the environment, Hotpoint reserves the right to use quality recycled components to keep down customer costs and minimise material wastage.

Please dispose of packaging and old appliances carefully.

To minimise risk of injury to children, remove the plug and cut mains cable off flush with the appliance. Dispose of these parts separately to ensure that the appliance can no longer be plugged into a mains socket.



## Key Contacts

### After Sales Service

Over 1200 trained specialists, directly employed by us, ensure that you can have complete confidence in both the appliances and services we offer.



### Repair Service and Information Desk

UK: 08709 066 066

(Open 8 to 8 Mon - Fri, 8 to 6 Sat, 10 to 4 Sun & Bank Holidays)

[www.theservicecentre.co.uk](http://www.theservicecentre.co.uk)

Republic of Ireland: 1850 302 200

Note: Our operators will require the following information:

Model number:

Serial number:

### Extended Warranties

UK: 08709 088 088

(Open 8 to 8 Mon - Sun)

[www.theservicecentre.co.uk](http://www.theservicecentre.co.uk)

Republic of Ireland: 1850 502 200

### Genuine Parts and Accessories

UK: 08709 077 077

(Open 8-30 to 5-30 Mon - Fri & 9 to 12 Sat)

[www.theservicecentre.co.uk](http://www.theservicecentre.co.uk)

Republic of Ireland: (01) 842 6836