

INSTALLATION INSTRUCTIONS

ELECTRIC SPOUT ROTATOR KIT
MFG. NO. 1690116

To install this electric spout rotator kit, proceed as follows:



WARNING

For your personal safety, stop tractor engine, set parking brake, and remove ignition key before attempting to install this kit.

1. Disconnect negative cable from battery terminal and fasten it away from the battery. Sparking can cause personal injury or damage to the machine if negative cable is not removed.
2. Remove tractor steering wheel and then the four Phillips head screws holding the dash. Raise the dash carefully for access to the wiring. Take care not to disconnect any wires while lifting dash.
3. Install spout rotator toggle switch (see figure 1) in the top hole (farthest from seat) of the dash. Position switch so toggle lever moves left and right when actuated. On some older model tractors it is necessary to drill a 1/2 inch diameter hole for the switch.
4. The main wiring harness (item 16, figure 2) is installed along the left-hand side of the tractor frame, and up into the dash area. Connect the two clip ends of the wiring harness to the outside terminals of the toggle switch. Install the red lead on the right-hand terminal (viewed from rear) and the black lead on the left terminal (see figure 1).

5. For older model tractors without terminal board (see figure 2). First examine the small connector (item 17, figure 2). Note the two passages in connector, one blocked off and the other going all the way through. Cut off the clip from one end of the short wire (item 21) and insert that end into the connector so it butts up against the blocked passages. Then place the wire that runs from the tractor ignition switch to the generator warning light into the open passage of the connector. With both wires in the connector, squeeze it shut with a pliers and wrap the connector flap into place. Now install the other end of the short wire on the toggle switch center terminal (see figure 1).

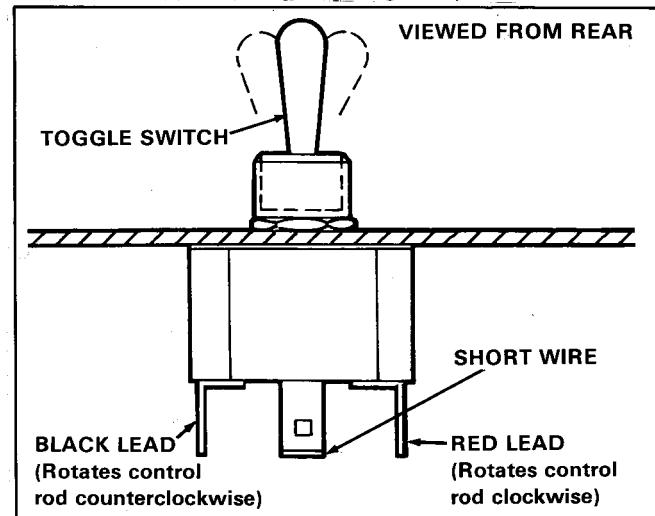

Figure 1. Installing Switch

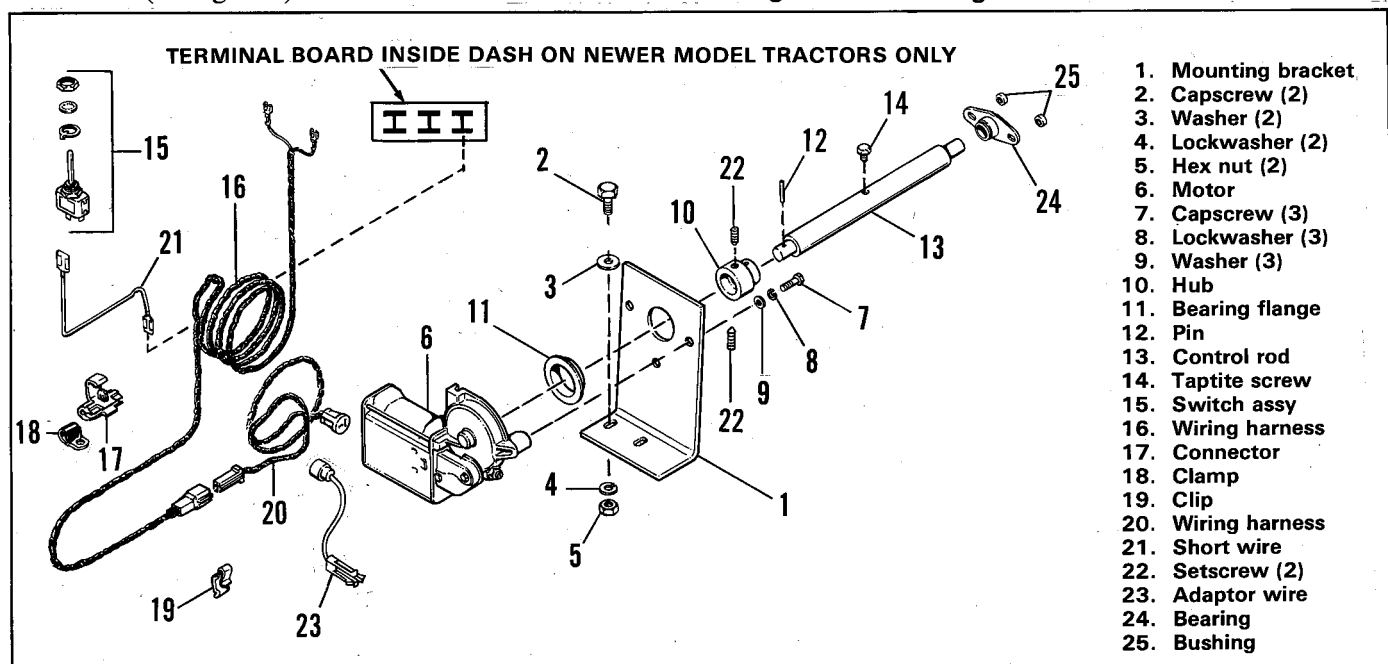

Figure 2. Wiring and Spout Rotator Assemblies

6. For newer model tractors with a terminal board (see figure 2). Install one end of the short wire (item 21) on toggle switch center terminal (see figure 1). Install other end of short wire on any open terminal on terminal board (see figure 2). The connect (item 17) is not used.
7. Reinstall dash and steering wheel. Reconnect negative battery cable. Turn ignition key to ON position to ensure it is functioning properly and no wires were accidentally disconnected. Remove key after checking. Install the cable clip (item 19, figure 2) on frame behind left cylinder shroud to hold wiring harness along the left-hand tractor frame.
8. Check snowthrower, noting how the spout control cable is attached to the spout as it will be removed and then reinstalled later.
9. Remove all existing spout control items.
10. Install the new bearing (item 24, figure 2) in holes shown in figure 3. The two bushings (item 25, figure 2) go between bearing and housing. On older model units, these holes have to be drilled in the housing (see figure 3 to locate holes for drilling).

DRILLING NEW HOLES (Figure 3)

Remove the existing control rod bushing. Measure 5" on an even plane from the inside existing hole to where a new hole must be drilled. Drill a 1/4" hole. Using the control bushing as a template, drill the second hole and install the bushing. Remove the capscrew that helps secure the deflector if it interferes with the mounting of the bushing.

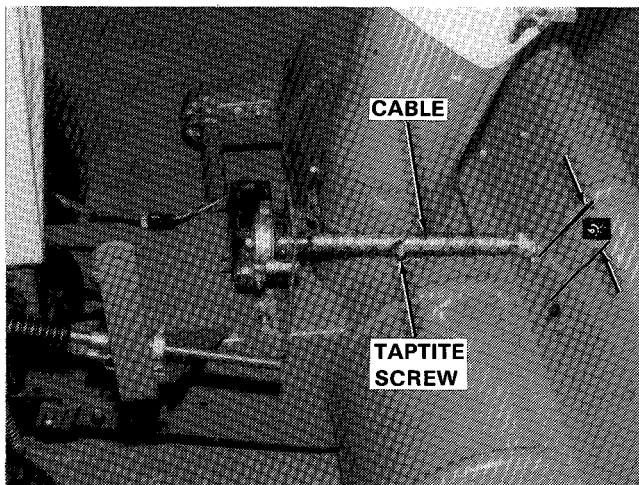

Figure 3. Reposition Rod Bushing

11. Assemble the motor (6), hub (10), bearing flange (11), bracket (1), and control rod (13) as shown in figure 2.
12. Insert front of control rod fully into bushing on housing (see figure 4). Then move the motor bracket until the front of the control rod is parallel, both horizontally and vertically, with the hub (22) at the other end. This is very important; in some cases it may be necessary to bend the bracket.
13. When properly aligned, hold the bracket still and secure it with the two capscrews, lockwashers, flat washers, and nuts provided. On some older model snowthrowers it may be necessary to drill the mounting holes. Use the bracket, in its correct position, as a template. Mark the holes and drill two 3/8 inch holes.
14. Install the original spout control cable on the new control rod (13) with the tapite screw (14) and connect it to the spout. See figure 3.
15. Install the locking end of the adaptor wire (item 23, figure 2) to the motor, and the other end to the shorter wiring harness (item 20). Loop wires as shown in figure 4 and secure with electrical tape; this helps to keep tension off the connection.
16. Secure the harness to the housing with the clamp (item 18). See figure 4.
17. When installing the snowthrower, plug the snowthrower wiring harness to the tractor wiring harness to operate the electric spout rotator. See figure 4.

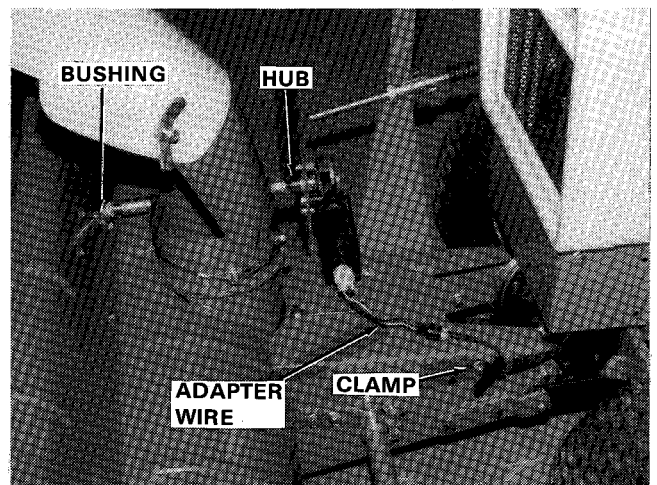

Figure 4. Installing Cable and Wires