

ASSEMBLY & OPERATING INSTRUCTIONS

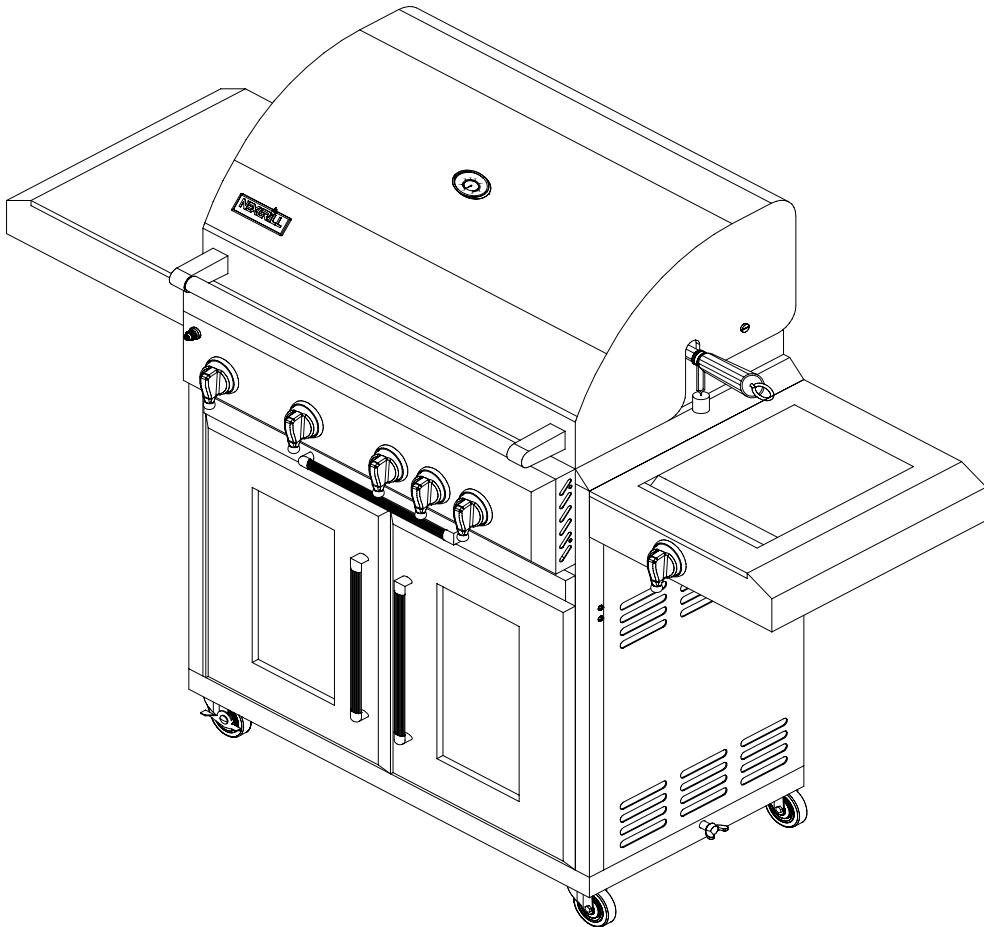

Model: 720-0439

FOR PROPANE GAS USE ONLY

FOR OUTDOOR USE ONLY

J19Y06P-1



**PLEASE CONTACT 1-866-984-7455 FOR ASSISTANCE
ABOUT ASSEMBLY OR GRILL OPERATION
DO NOT RETURN TO THE PLACE OF PURCHASE**

MESSAGE TO OUR CONSUMERS

Thank you for selecting our stainless steel gas grill.

Because this appliance contains features which may not be found on other grills, we recommend that you read this entire booklet before your first use. Keep it in a handy place as it has answers to questions that may occur during future use.

Read this booklet carefully and be sure your gas grill is properly assembled, installed and maintained. Failure to follow these instructions could result in serious bodily injury and/or property damage. This gas grill is intended for outdoor use only and is not intended to be installed in or on recreational vehicles or boats.

NOTE TO INSTALLER: Leave these instructions with the consumer after installation.

NOTE TO CONSUMER: Retain for future reference.

IMPORTANCE



<p> Danger</p> <p>If you smell gas:</p> <ol style="list-style-type: none">1 Shut off gas to the appliance.2 Extinguish any open flame.3 Open lid4 If odor continues, keep away from the appliance and immediately call your gas supplier or your fire department.	<p> Warning</p> <ol style="list-style-type: none">1. Do not store or use gasoline or other flammable vapors and liquids in the vicinity of this or any other appliance.2. An LP cylinder not connected for use shall not be stored in the vicinity of this or any other appliance.
<p>WARNING</p> <p>Combustion byproducts produced when using this product contain chemicals known to the State of California to cause cancer, birth defects, or other reproductive harm.</p>	<p>WARNING</p> <p>Failure to comply with these instructions could result in a fire or explosion that could cause serious bodily injury, death, or property damage.</p>
<p>WARNING</p> <p>Your grill will get very hot. Never lean over the cooking area while using your grill. Do not touch cooking surfaces, grill housing, lid or any other grill parts while the grill is in operation, or until the gas grill has cooled down after use. Keep any electrical supply cord and the fuel supply hose away from any heated surface. Failure to comply with these instructions may result in serious bodily injury or death.</p>	

TABLE OF CONTENTS

SECTION ONE

Table of Contents & Importance	
Precautions-----	1-2
Placement of the Grill-----	3

SECTION TWO

Assembly Instructions-----	4-7
To Match Light The Grill-----	8
Gas Hook Up-----	9-10
Installer Final Check List-----	10
Leak Testing-----	11-12

SECTION THREE

Operating Instructions-----	13
Grill Lighting Instructions-----	14-17
Lighting Illustration-----	18

SECTION FOUR

Care & Maintenance-----	19-20
-------------------------	-------

SECTION FIVE

Trouble Shooting-----	21-24
Exploded View-----	25
Part List-----	26-27
Ordering Parts & Grilling Hints-----	28

SECTION SIX

Grill Cooking Chart-----	29-31
--------------------------	-------

SECTION SEVEN

Grill Recipe Suggestions-----	32-34
-------------------------------	-------

SECTION EIGHT

Converting to Natural Gas-----	35-36
Instructions for Converting to Natural Gas-----	37
Gas Conversion-----	38-43

SECTION NINE

Limited Warranty-----	44
-----------------------	----

PRECAUTIONS

WARNING

Do not try to light this appliance without first reading the “LIGHTING INSTRUCTIONS” section in this manual.

TESTED IN ACCORDANCE WITH ANS Z21.58a •CSA 1.6a-2006 STANDARD FOR OUTDOOR COOKING GAS APPLIANCES. THIS GRILL IS FOR OUTDOOR USE ONLY.

Check your local building codes for the proper method of installation. In the absence of local codes, this unit should be installed in accordance with the National Fuel Gas Code ANSI Z223.1/NFPA 54, OR CSA B149.1 Natural Gas and Propane Installation Code, and the National Electrical Code, ANSI/NFPA 70, or Propane storage and handling code, B149.2.

CALIFORNIA PROPOSITION 65-WARNING

The burning of gas fuel generates some by-products, which are on the list of substances, which are known by the State of California to cause cancer or reproductive harm. California law requires businesses to warn customers of potential exposure to such substances. To minimize exposure to these substances, always operate this unit according to the use and care manual, ensuring you provide good ventilation when cooking with gas.

SAFETY PRACTICES TO AVOID PERSONAL INJURY

When properly cared for, your stainless steel grill will give safe, reliable service for many years. However, extreme care must be used since the grill produces intense heat and that can increase accident potential. When using this appliance basic safety practices must be followed, including the following:

Read this Care and Use Manual carefully and completely before using your grill to reduce the risk of fire, burn hazard or other injury.

Do not repair or replace any part of the grill unless specifically recommended in this manual. All other service should be referred to a qualified technician.

CHILDREN SHOULD NOT BE LEFT ALONE OR UNATTENDED IN AN AREA WHERE THE GRILL IS BEING USED. NEVER ALLOW THEM TO SIT, STAND OR PLAY ON OR AROUND THE GRILL AT ANY TIME.

- (a) Do not store a spare LP-gas cylinder under or near this appliance;**
- (b) Never fill the cylinder beyond 80 percent full; and**
- (c) If the information in (a) and (b) is not followed exactly, a fire causing death or serious injury may occur.**

PRECAUTIONS

DO NOT STORE ITEMS OF INTEREST TO CHILDREN AROUND OR BELOW THE GRILL OR IN THE CART. NEVER ALLOW CHILDREN TO CRAWL INSIDE OF THE CART.

Never let clothing, kitchen mitten or other flammable materials come in contact with or too close to any grate, burner or hot surface until it has cooled. Fabric may ignite and result in personal injury.

For personal safety, wear proper apparel. Loose fitting garments or sleeves should never be worn while using this appliance. Some synthetic fabrics are highly flammable and should not be worn while cooking.

Only certain types of glass, heat-proof glass ceramic, earthenware, or other glazed utensils are suitable for grill use. These types of materials may break with sudden temperature changes. Use only on low or medium heat settings according to the manufacturer's directions.

Do not heat unopened food containers as a build-up of pressure may cause the container to burst.

Use a covered hand when opening the grill lid. Never lean over an open grill.

WHEN LIGHTING A BURNER, ALWAYS PAY CLOSE ATTENTION TO WHAT YOU ARE DOING. BE CERTAIN YOU ARE TURNING THE IGNITER LABELED FOR THE BURNER YOU INTEND ON USING.

When using the grill, do not touch the grill rack, burner grate or immediate surroundings as these areas become extremely hot and could cause burns. Use only dry potholders.

Moist or damp potholders on hot surfaces may cause burns from steam. Do not use a towel or bulky cloth in place of potholders. Do not let potholders touch hot portions of the grill rack.

Grease is flammable. Let hot grease cool before attempting to handle it. Avoid letting excess grease deposits collect in the grease tray at the bottom of the grill's firebox. Clean often.

DO NOT USE ALUMINUM FOIL TO LINE THE GRILL RACKS OR GRILL BOTTOM. This can severely upset combustion air flow or trap excessive heat in the control area.

For proper lighting and performance of the burners keep the burner ports clean. It is necessary to clean them periodically for optimum performance. The burners will only operate in one position and must be mounted correctly for safe operation.

Clean the grill with caution. Avoid steam burns; do not use a wet sponge or cloth to clean the grill while it is hot. Some cleaners produce noxious fumes or can ignite if applied to a hot surface.

INSECT WARNING!!! Spiders and insects can nest in the burners of this and any other grill, and cause the gas to flow improperly. This is a very dangerous condition which can cause a fire to occur behind the valve panel, thereby damaging the grill and making it unsafe to operate. Inspect the grill twice a year.

Be sure all grill controls are turned off and the grill is cool before using any type of aerosol cleaner on or around the grill. The chemical that produces the spraying action could, in the presence of heat, ignite or cause metal parts to corrode.

PRECAUTIONS

Do not use the grill for cooking excessively fatty meats or products which promote flare-ups. Do not operate the grill under unprotected combustible construction. Use only in well ventilated areas. Do not use in buildings, garages, sheds, breezeways or other such enclosed areas. **THIS UNIT IS FOR OUTDOOR USE ONLY.**

Keep the area surrounding the grill free from combustible materials, trash, or combustible fluids and vapors such as gasoline or charcoal lighter fluid. Please check the surrounding area before use. And keep a minimum of 24”(61cm) clearance from combustible material. Do not obstruct the flow of combustion and ventilation air. Keep the ventilation openings of the cylinder enclosure free and clear from debris. This must be checked before each use. If the unit is stored indoors ensure that it is cool. If propane is used, the cylinder must be unhooked and the propane cylinder stored

outside in a well ventilated area, out of the reach of children.

DO NOT USE BRIQUETTES OF ANY KIND IN THE GRILL.

This stainless steel grill is designed for optimum performance without the use of briquettes. Do not place briquettes on the flame tamer as this will block off the area for the grill burners to vent. Adding briquettes can damage ignition components and knobs, and void the warranty.

Keep the back of the cart free and clear from debris. Keep any electrical supply cord, or the rotisserie motor cord away from the heated areas of the grill.

Never use the grill in extremely windy conditions. If located in a consistently windy area (oceanfront, mountaintop, etc.) a windbreak will be required. Always adhere to the specified clearance.

NEVER USE A DENTED OR RUSTY PROPANE TANK.

PLACEMENT OF THE GRILL

CLEARANCE

To Non-Combustible Construction

A minimum of 24”(61cm) clearance from the back of the grill to non-combustible construction is required for the lid to open fully.

DO NOT INSTALL THIS UNIT INTO COMBUSTIBLE ENCLOSURES!

LOCATION

When determining a suitable location take into account concerns such as exposure to wind, proximity to traffic paths and keeping any gas supply lines as short as possible.

Locate the grill only in a well-ventilated area. Never locate the grill in a building, garage,

breezeway, shed or other such enclosed areas without an approved ventilation system. During heavy use, the grill will produce a lot of smoke. Lock the wheels after the grill is placed in a suitable position according to the sticker located behind the right door. Keep any electrical supply cord and the fuel supply hose away from any heated surfaces. Storage of an outdoor gas cooking appliance indoors is permissible only if the cylinder is disconnected and removed from the appliance.

This outdoor cooking gas appliance shall be used only outdoor and shall not be used in a building, garage or any other enclosed area. This appliance is not intended to be installed in or on recreational vehicles and/or boats

ASSEMBLY INSTRUCTIONS

PLEASE READ THE INSTRUCTIONS CAREFULLY AND FOLLOW STEP BY STEP.

TOOLS REQUIRED:

(1) PHILIPS HEAD SCREWDRIVER – NOT PROVIDED

STEP 1:

- A. The screws used to attach the side shelf are already screwed into the left panel (see the figure below). Remove the screws from the left panel, align with the holes in the side shelf, and then re-screw into the holes on the left panel of the grill.
- B. The screws used to attach the side burner are already screwed into the right panel (see the figure below). Remove the screws from the right panel, align with the holes in the side burner, and then re-screw into the holes on the right panel of the grill.

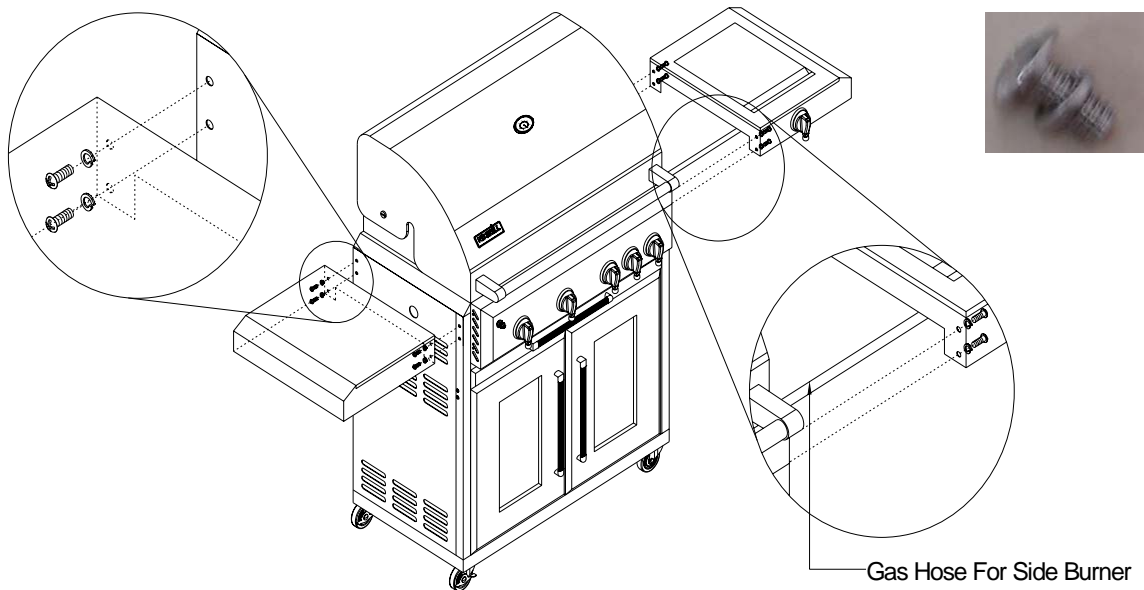

ASSEMBLY INSTRUCTIONS

STEP 2: Side Burner Assembly

A. Push valve into side burner control panel. Insert screws from the front side of control panel and tighten.

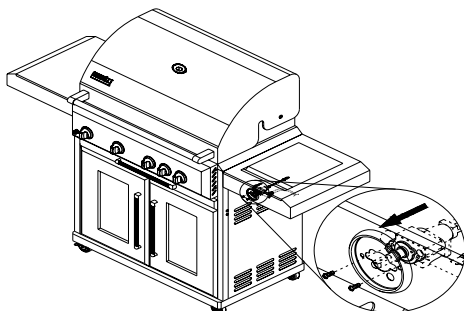

B. Push the side burner control knob into the valve stem and tighten it using the Allen Wrench.

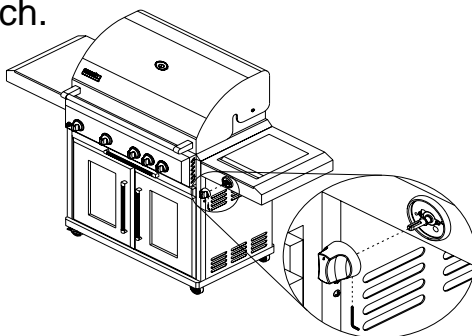

C. Insert valve venturi into the side burner and tighten securely using an adjustable wrench.

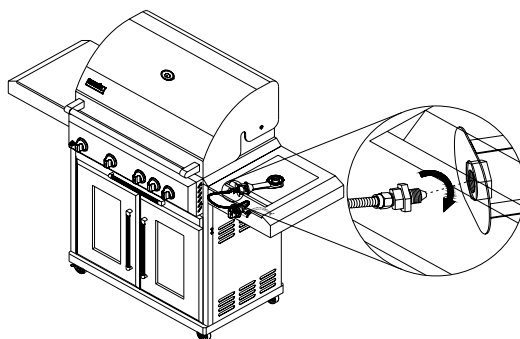

D. Connect ignition wire with valve.

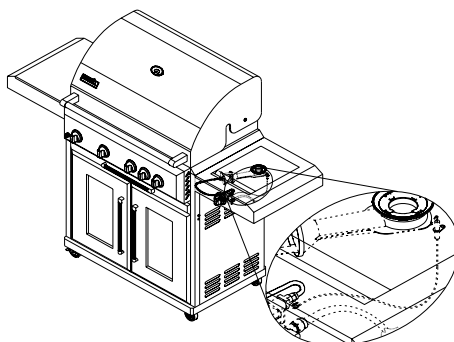

ASSEMBLY INSTRUCTIONS

STEP 3: Battery is inserted for the rotisserie burner. To install the battery, turn the ignition button cap counterclockwise and remove it. Replace the ignition button cap after the battery is installed.

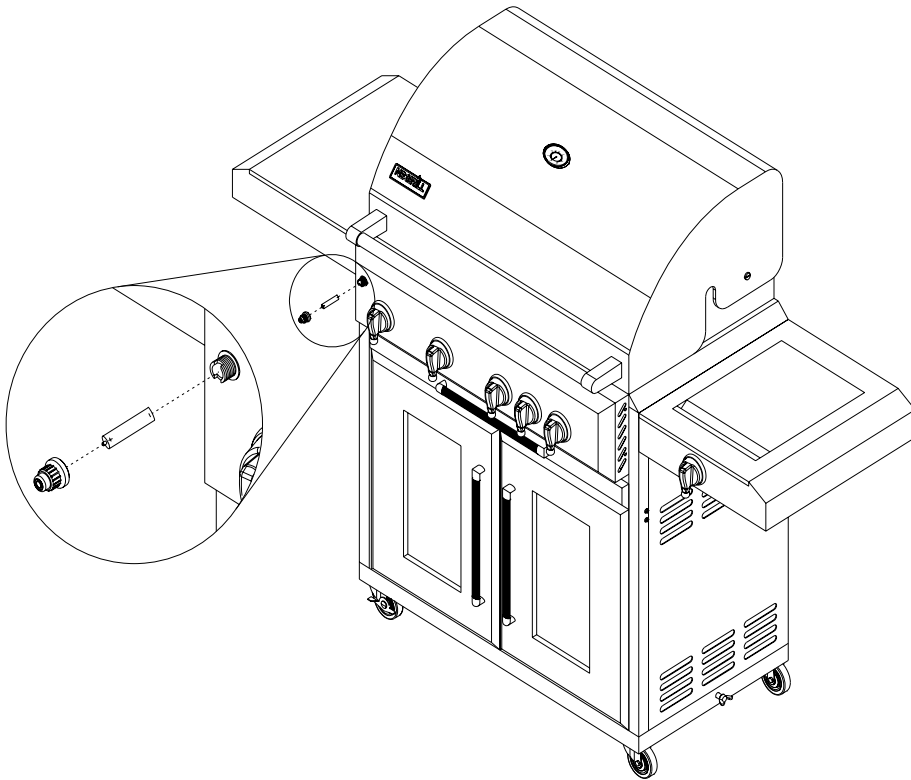

ASSEMBLY INSTRUCTIONS

STEP 4: Attach propane gas tank to regulator inlet fitting by turning the regulator clockwise as shown in figure below. LP gas cylinder must be fitted with a listed overfill prevention device (OPD). Open the door and pull out the tray, place the gas tank cylinder in the tank tray, then use retention kit that showed as below diagram to **secure the tank cylinder. Make sure tank is leveled with bottom panel for proper vapor withdrawal.**

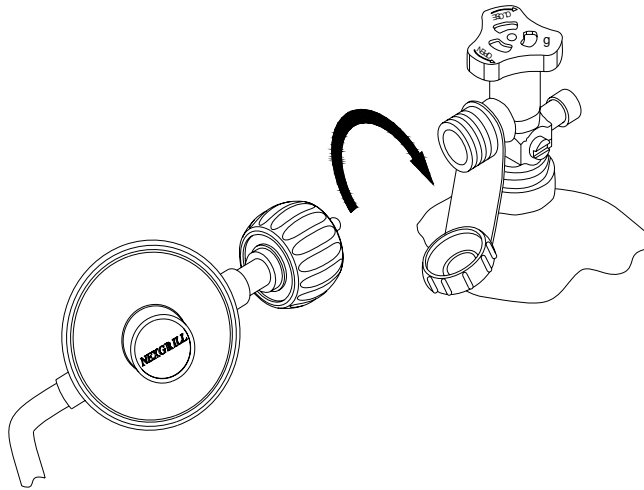

CYLINDER TANK FIXED

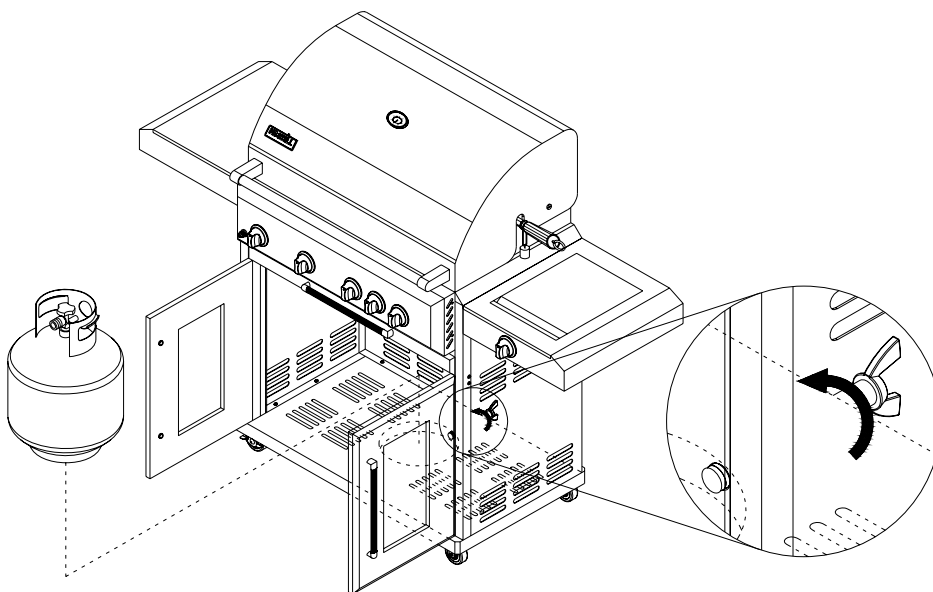

ASSEMBLY INSTRUCTIONS

STEP 5: The screws for rotisserie drive motor bracket are attached to the motor bracket. Remove the screws and install the rotisserie motor bracket as shown in the figure below. Assemble the rotisserie skewer as shown in the figure below.

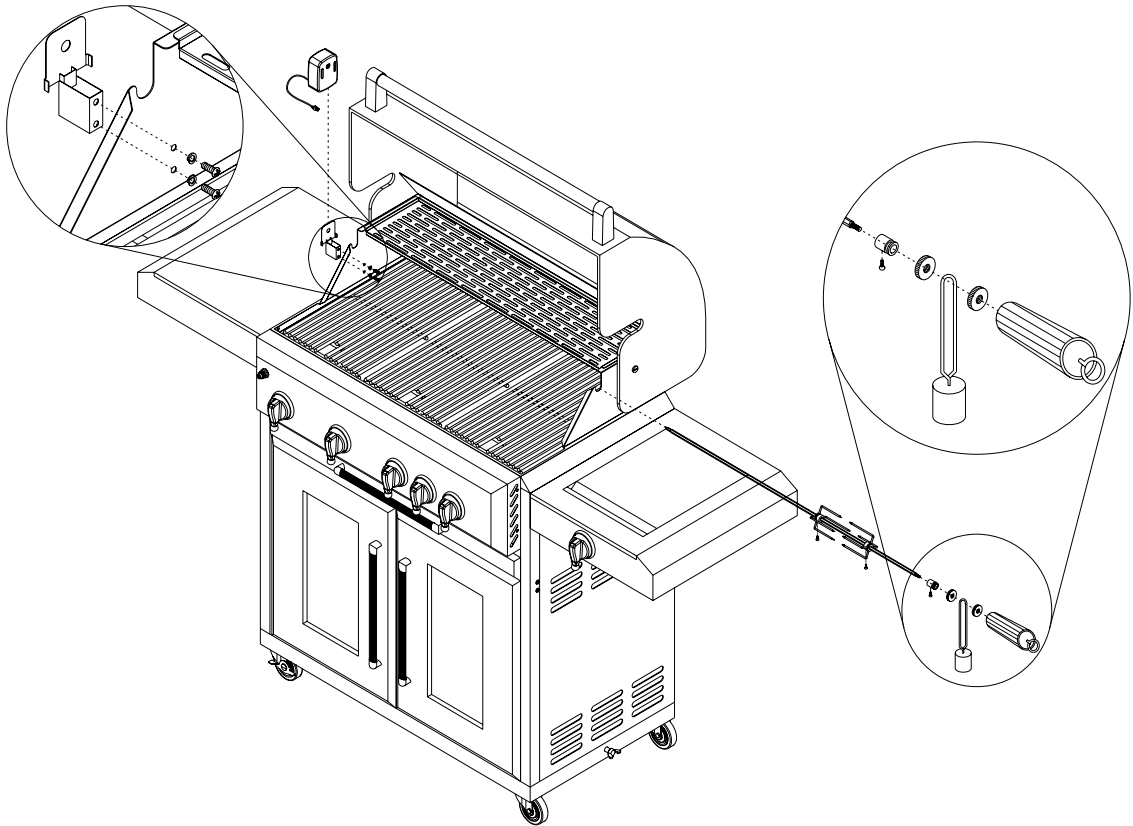

TO MATCH LIGHT THE GRILL

1. If the burner will not light after several attempts then the burner can be match lit.
2. If you've just attempted to light the burner with the igniter, allow 5 minutes for any accumulated gas to dissipate. Keep your face and hands as far away from the grill as possible. Insert a lit extended match or lighter through the cooking grids to the burner. Press the control knob and rotate left to the HI setting, continue to press the knob until the burner ignites. Burner should light immediately. If the burner does not light in 4 seconds turn the knob off, wait 5 minutes and try again.

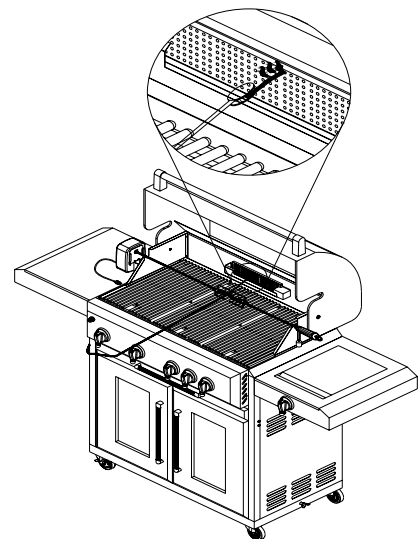
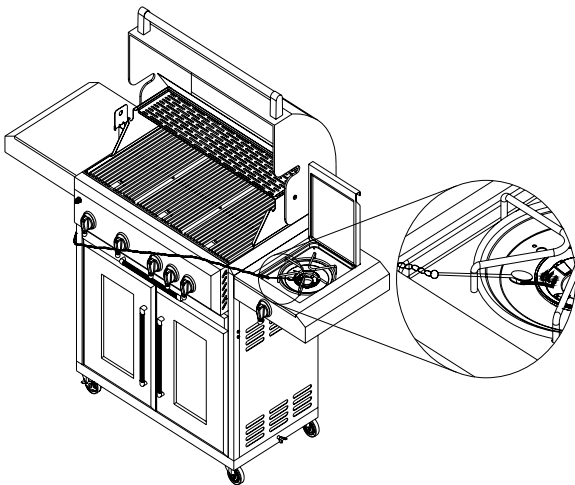
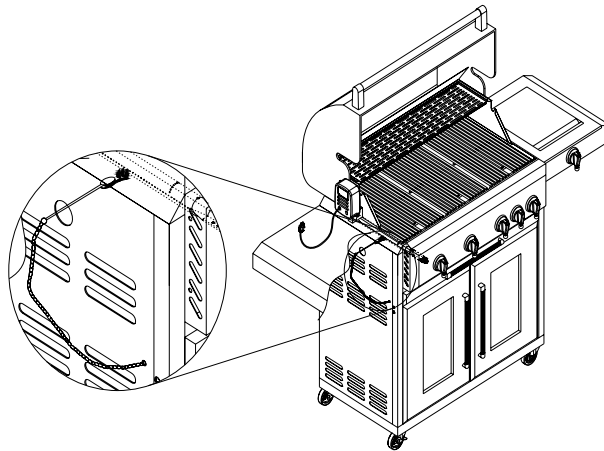

GAS HOOK-UP

NEVER CONNECT AN UNREGULATED GAS SUPPLY LINE TO THE APPLIANCE. USE THE REGULATOR/HOSE ASSEMBLY SUPPLIED WITH THIS OUTDOOR GAS APPLIANCE.

This is a liquid propane configured grill. Do not attempt to use a natural gas supply.

Total gas consumption (per hour) of this stainless steel gas grill with all burners on "IGNITE/HI":

Main burner	30,000 Btu/hr
Side burner	12,000 Btu/hr
Sear Burner	15,000 Btu/hr
<u>Rear burner</u>	<u>10,000 Btu/hr</u>
Total	67,000 Btu/hr

L.P. TANK REQUIREMENT

A dented or rusty L.P. tank may be hazardous and should be checked by your L.P. supplier. Never use a cylinder with a damaged valve. The L.P. gas cylinder must be constructed and marked in accordance with the specifications for L.P. gas cylinders of the U.S. Department of Transportation (DOT) or the National Standard of Canada, CAN/CSA-B339, Cylinders, Spheres and Tubes for Transportation of Dangerous Goods; and Commission, as applicable. Overfilling prevention device (OPD) shall be provided on cylinder & QCCI connection on the cylinder valve, ANSI/CGA-V-1. The cylinder supply system must be arranged for vapor withdrawal. Make sure tank is leveled with bottom panel for proper vapor withdraw. The cylinder must include a collar to protect the cylinder valve. The cylinder must be provided with a shut off valve terminating in an L.P. gas supply cylinder valve outlet specified, as applicable, for connection type QCC1 in the standard for compressed gas cylinder valve outlet and inlet connection ANSI/CGA-V-1.

Manifold pressure: 11 inches water column (W.C.).

L.P. GAS HOOK-UP

Ensure that the rubber "O" Ring on the LP cylinder valve is in place and that the hose does not come into contact with the grease tray or the grill head. Set the liquid propane gas cylinder into the slide-out tray making sure that the cylinder is level with the bottom panel, thus allowing proper vapor withdrawal.

CONNECTION

Your stainless steel grill is equipped with gas supply orifices for use only with liquid propane gas. It is also equipped with a high capacity hose/regulator assembly for connection to a standard 20lb. L.P. cylinder (18-1/4" (46.35cm) high, 12-1/4"(31cm) diameter). To connect the L.P. gas supply cylinder, please follow the steps below:

1. Make sure tank valve is in its full off position (turn clockwise to stop)
2. Check tank valve to assure it has proper external male threads (type 1 connection per ANSIZ21.81)



3. Make sure all burner valves are in their off position.
4. Inspect valve connections, port, and regulator assembly. Look for any damage or debris. Remove any debris. Inspect hose for damage. Never attempt to use damaged or obstructed equipment. See your local L.P. gas dealer for repair.

GAS HOOK-UP

- When connecting regulator assembly to the valve, hand tighten the quick coupling nut clockwise to a complete stop. Do not use a wrench to tighten. Use of a wrench may damage the quick coupling nut and result in a hazardous condition.
- Open the tank valve fully (counterclockwise). Apply the soap solution with a clean brush to all gas connections. See below. If growing bubbles appear in the solution the connections are not properly sealed. Check each fitting and tighten or repair as necessary.
- If you have a gas connection leak you cannot repair, turn gas OFF at supply tank, disconnect fuel line from your grill and call 1-866-984-7455 or your gas supplier for repair assistance.
- Also apply soapy solution to the tank seams. See below. If growing bubbles appear, shut tank OFF and do not use or move it! Contact an LP gas supplier or your fire department for assistance

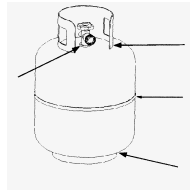

To disconnect L.P. gas cylinder:

- Turn the burner valves off.
- Turn the tank valve off fully (turn clockwise to stop).
- Detach the regulator assembly from the tank valve by turning the quick coupling nut counterclockwise.

INSTALLER FINAL CHECK LIST

- ✓ Specified clearance maintained 24”(61cm) from combustibles.
- ✓ All internal packaging removed.
- ✓ Knobs turn freely.
- ✓ Burners are tight and sitting properly on orifices.
- ✓ Pressure regulator connected and set. Gas connections to grill using hose & regulator assembly provided (pre-set for 11.0” water column).
- ✓ Unit tested and free of leaks.
- ✓ User informed of gas supply shut off valve location

PROPANE CYLINDER CAUTIONS

- Do Not store a spare LP-gas cylinder under or near this appliance.
- NEVER fill the cylinder beyond 80 percent full.
- If the information in “a” and “b” is not followed exactly, a fire causing death or serious injury may occur.

USER, PLEASE RETAIN THIS MANUAL FOR FUTURE REFERENCE.

LEAK TESTING

GENERAL

Although all gas connections on the grill are leak tested at the factory prior to shipment, a complete gas tightness check must be performed at the installation site due to possible mishandling in shipment, or excessive pressure unknowingly being applied to the unit. Periodically check the whole system for leaks following the procedures listed below. If the smell of gas is detected at anytime you should immediately check the entire system for leaks.

BEFORE TESTING

Make sure that all packing material is removed from the grill including the burner tie-down straps.

DO NOT SMOKE WHILE LEAK TESTING.

NEVER PERFORM LEAK TEST WITH AN OPEN FLAME.

Make a soap solution of one part liquid detergent and one part water. You will need a spray bottle, brush, or rag to apply the solution to the fittings. For the initial leak test, make sure the L.P. cylinder is full.

TO TEST

1. Make sure the control valves are in the "OFF" position, and turn on the gas supply.
2. Check all connections from the LP gas regulator and supply valve up to and including the connection to the manifold pipe assembly (the pipe that goes to the burners). Soap bubbles will appear where a leak is present.
3. If a leak is present, immediately turn off the gas supply and tighten the leaky fittings.
4. Turn the gas back on and recheck.
5. Should the gas continue to leak from any of the fittings, turn off the gas supply and contact customer service at 1-866-984-7455.



Only those parts recommended by the manufacturer should be used on the grill.

Substitution will void the warranty. Do not use the grill until all connections have been checked and do not leak.

GAS FLOW CHECK

Each grill burner is tested and adjusted at the factory prior to shipment; however, variations in the local gas supply may make it necessary to adjust the burners. The flames of the burners should be visually checked.

Flames should be blue and stable with no yellow tips, excessive noise or lifting. If any of these conditions exist, check to see if the air shutter or burner ports are blocked by dirt, debris, spider webs, etc. If you have any questions regarding flame stability, please call customer service 1-866-984-7455 .

ALWAYS CHECK FOR LEAKS AFTER EVERY L.P. TANK CHANGE

Check all gas supply fittings for leaks before each use. It is handy to keep a spray bottle of soapy water near the shut-off valve of the gas supply line. Spray all the fittings. Bubbles indicate leaks.

CAUTIONS

Place dust cap on cylinder valve outlet when the cylinder is not in use. Only install the type of dust cap on the cylinder valve outlet that is provided with the cylinder valve. Other types of caps or plugs may result in leakage of propane.

The gas must be turned off at the supply cylinder when the unit is not in use.

If the appliance is stored indoors, the cylinder must be disconnected and removed from the appliance. Cylinders must be stored outdoors in a well-ventilated area out of the reach of children, and must not be stored in a building, garage, or any other enclosed area.



Your grill is ready to use!

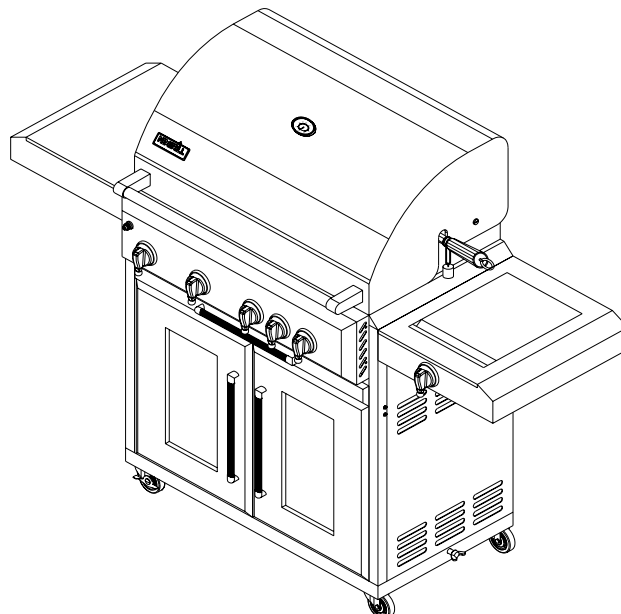

OPERATING INSTRUCTIONS

GENERAL USE OF THE GRILL AND ROTISSERIE

Each main burner is rated at 10,000 Btu/hr. The main grill burners encompass the entire cooking area and are side ported to minimize blockage from falling grease and debris. Above the burners are stainless steel radiant (flame tamer). The igniter knobs are located on the lower center portion of the valve panel. Each rotary igniter is labeled on the control panel.

USING THE GRILL

Grilling requires high heat for searing and proper browning. Most foods are cooked at the "HI" heat setting for the entire cooking time. However, when grilling large pieces of meat or poultry, it may be necessary to turn the heat to a lower setting after the initial browning. This cooks the food through without burning the outside. Foods cooked for a long time or foods basted with a sugary marinade may need a lower heat setting near the end of the cooking time.

NOTE: This stainless steel grill is designed to grill efficiently without the use of lava rocks or briquettes of any kind. Heat is radiated by the stainless steel flame tamers positioned above each burner.

NOTE: The hot grill sears the food, sealing in the juices. The longer the preheat, the faster the meat browns and the darker the grill marks.

WARNING: IMPORTANT!

USING THE SIDE BURNER:

Inspect the gas supply hose prior to turning the gas "ON". If there is evidence of cuts, wear or abrasion, it must be replaced prior to use. Do not use the side burner if the odor of gas is present.

USING ROTISSERIE BURNER

Your grill is capable of performing back burner rotisserie cooking. Light the rear burner as described in the lighting instructions, see page 20. Once lit, the rotisserie burner will reach cooking temperatures in about 1 minute.

DO NOT LEAVE THE GRILL UNATTENDED WHILE COOKING.

OPERATING INSTRUCTIONS

CAUTION: PLEASE TAKE OFF THE WARMING RACK WHEN USING THE ROTISSERIE BURNER. THE HIGH HEAT COMING FROM THE ROTISSERIE BURNER MAY CAUSE THE WARMING RACK TO BEND.

GRILL LIGHTING INSTRUCTIONS

WARNING: IMPORTANT!

BEFORE LIGHTING...

Inspect the gas supply hose prior to turning the gas "ON". If there is evidence of cuts, wear, or abrasion, it must be replaced prior to use. Do not use the grill if the odor of gas is present. Only the pressure regulator and hose assembly supplied with the unit should be used.

Never substitute regulators and hose assembly for those supplied with the grill. If a replacement is necessary, contact the manufacturer for proper replacement. The replacement must be that specified in the manual.

Screw the regulator (type QCC1) onto the tank. Leak check the hose and regulator connections with a soap and water solution before operating the grill.

TO LIGHT THE GRILL BURNER:

Make sure all knobs are "OFF" then turn on the gas supply from the LP tank. Always keep your face and body as far from the grill as possible when lighting.

Your stainless steel grill has an exclusive patented built-in ignition. The igniter is built in to the valve. To ignite each burner simply push and turn the control knobs to the HI setting, you will hear the valve click as it sends a spark to the pilot flame. If the burner does not light wait 5 minutes for any excess gas to dissipate and then retry.

GRILL LIGHTING INSTRUCTIONS

WARNING: Always keep your face and body as far away from the burner as possible when lighting.

TO LIGHT THE SIDE BURNER

To light the side burner, remove any cooking utensils from the burner grate. Push and turn the control knob counterclockwise to the "IGNITE/HI" position. If the burner does not light, turn the control knob to "OFF". If the smell of gas is detected and the igniter is not functioning, immediately turn the control knob "OFF". Allow 5 minutes for any accumulated gas to dissipate. If the side burner igniter is not functioning, see the following section for match lighting.

TO LIGHT THE ROTIS BURNER:

Open the lid, push the knob for about 5 seconds without rotating. This will allow time for the gas to flow into the rear burner. Continue pushing for 5 seconds then turn the knob to the IGNITE/HI position, then press the igniter button to light the rotisserie burner. If the burner does not light, turn the control knob to "OFF", wait 5 minutes and try again. If the igniter does not function, follow the instruction above for match lighting.

TO MATCH LIGHT THE GRILL

If the burner will not light after several attempts then the burner can be match lit.

Lighting rod instruction:

Match light extension rod

Use this device to match light your burners. Simply place a lighted match between the coils on the end of the extension rod and hold next to the burner to ignite.

If you've just attempted to light the burner with the igniter, allow 5 minutes for any accumulated gas to dissipate. Keep your face and hands as far away from the grill as possible. Insert a lit match attached to the lighting rod through the cooking grids to the burner.(see next page) Press the control knob and rotate left to the IGNITE/HI setting, continue to press the knob until the burner ignites. Burner should light immediately. If the burner does not light in 4 seconds turn the knob off, wait 5 minutes and try again.

TO MATCH LIGHT THE SIDE BURNER

Hold a lit extended match or lighter near the side burner ports, turn the control knob counterclockwise to "IGNITE/HI". Move your hand immediately once the burner is lit. Rotate the control knob to the desired setting.

Keep a spray bottle of soapy water near the gas supply valve and check the connections before each use.

Do not attempt to light the grill if odor of gas is present. Call for service 1-866-984-7455.

GRILL LIGHTING INSTRUCTIONS

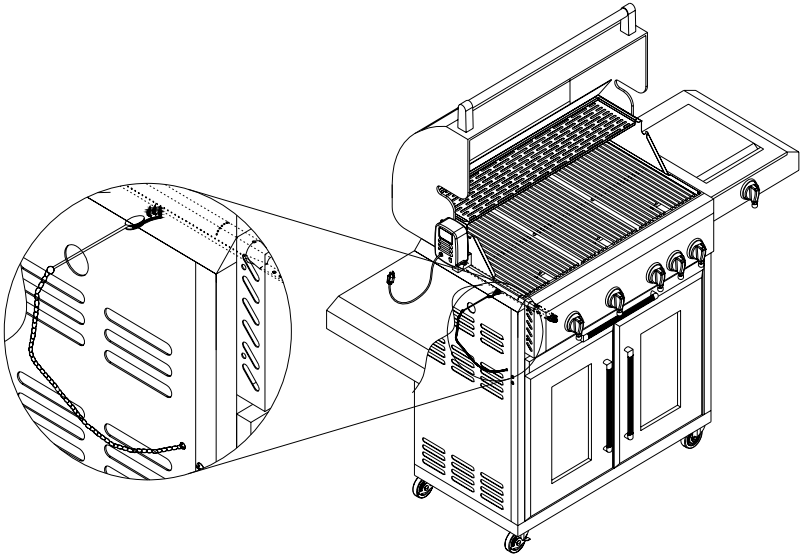

GRILL LIGHTING INSTRUCTIONS

FLAME CHARACTERISTICS

Check for proper burner flame characteristics.

Burner flames should be blue and stable with no yellow tips, excessive noise, or lifting. If any of these conditions exist call our customer service line. If the flame is yellow, it indicates insufficient air. If the

flame is noisy and tends to lift away from the burner, it indicates too much air.

Each burner is adjusted prior to shipment; however, variations in the local gas supply may make minor adjustments necessary.

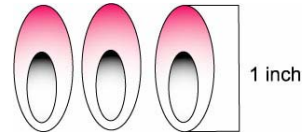

Visually check the burner flames prior to each use, The flames should look like this picture, if they do not, refer to the burner maintenance part of this manual



Approximate 1 1/2 " Flame Height

LIGHTING ILLUSTRATION

Main & Side Burner Lighting Illustration

Step 1.
Make sure the Lid is open



Step 2.
Push and turn main or side burner knobs to "HI" position. Pilot torch will light. Hold for 3-4 seconds until burner is lit.



Step 3.
You may need to try 3 or 4 times to light the burner. After the burner is lit, adjust the knob as desired.



Rotisserie Burner or Searing Burner Lighting Illustration

Step to light the Rotisserie Burner :

Push and turn the rotisserie knob to "ON" position and hold for 3-4 seconds then push electronic ignition button at the same time, until burner is lit.



Step to light the Searing Burner:

Push and turn the Searing knob to "HI" position and hold for 3-4 seconds and push electronic ignition button, until burner is lit. Once it is lit, release electronic ignition button, and hold the Searing knob for another 15 seconds to be sure the burner stay lit.



STAINLESS STEEL

The grill is made from non-rusting and non-magnetic stainless steel. There are many different stainless steel cleaners available. Always use the mildest cleaning procedure first, scrubbing in the direction of the grain. To touch up noticeable scratches in the stainless steel, sand very lightly with dry 100 grit emery paper in the direction of the grain. Specks of grease can gather on the surfaces of the stainless steel and bake on to the surface and give the appearance of rust. For removal use an abrasive pad in conjunction with a stainless steel cleaner.

GRILL RACK

The easiest way to clean the grill is immediately after cooking is completed and after turning off the flame. Wear a barbeque mitt to protect your hand from the heat and steam. Dip a brass bristle barbeque brush in tap water and scrub the hot grill. Dip the brush frequently in the bowl of water. Steam, created as water contacts the hot grill, assists the cleaning process by softening any food particles. The food particles will fall and burn. If the grill is allowed to cool before cleaning, cleaning will be more difficult.

ENSURE THAT THE GAS SUPPLY AND THE KNOBS ARE IN THE “OFF” POSITION.

GRILL BURNERS

Extreme care should be taken when removing a burner as it must be correctly centered on the orifice before any attempt is made to relight the grill (Please refer to page 20). Frequency of cleaning will depend on how often you use the grill.

MAIN GRILL BURNER CLEANING

Ensure the gas supply is off and the knobs are in the “OFF” position. Make sure the grill is cool. Clean the exterior of the burner with a wire brush. Clear stubborn scale with a metal scraper. Clear any clogged ports with a straightened paper clip. Never use a wooden toothpick as it may break off and clog the port. Please note if insects or other obstructions are blocking the flow of gas through the burner, and if so you will need to call our customer service line.

GREASE TRAY CLEANING:

The grease tray should be emptied and wiped down periodically and washing a mild detergent and warm water solution. A small amount of sand or cat litter may be placed in bottom of grease tray to absorb the grease. Check the grease tray frequently, don't allow excess grease to accumulate and overflow out of the grease tray.

BURNER CLEANING:

1. Turn off the gas supply, and make sure all the knobs are in the “OFF” position.
2. Wait for the grill to cool. and clean the exterior of the burner with a wire brush. Use a metal scraper to remove stubborn stains.
3. Clear clogged port with a straightened paper clip. Never use a wooden toothpick as it may break off and clog the port
4. If insects or other obstructions are blocking the flow of gas through the burner, call customer service at 1-800-913-8999.

Make sure to center the burner over the orifice.

CARE AND MAINTENANCE

HOW TO REPLACE MAIN BURNER

Step 1. Insert the burner onto the orifice.



Step 2. Secure the main burner on the back wall of fire box with 2 screws.



STAINLESS STEEL :

There are many different stainless steel cleaners available. Always use the mildest cleaning procedure first, scrubbing in the direction of the grain. Do not use steel wool as it will scratch the surface. To touch up noticeable scratches in the stainless steel, sand very lightly with dry 100 grit emery paper in the direction of the grain.

BURNER GRATE:

The top burner grate is stainless steel. To avoid burns do not clean a hot grate. They may be wiped while in place with hot, soapy water, rinsed and wiped dry. Never immerse a hot grate in water.

CAUTION:

1. Keep outdoor cooking gas appliance area clear and free from combustible materials, gasoline and other flammable vapors and liquids.
2. Do not obstruct the flow of combustible and ventilation air.
3. Keep the ventilation openings of the cylinder enclosure free and clear from debris.
4. Flame Characteristics, refer to “Flame Characteristics” on page 17.
5. Checking and cleaning burner/venturi tubes for insects and insect nests. A clogged tube can lead to a fire beneath the grill.

TROUBLE SHOOTING

SPIDER AND INSECT WARNING!!!

Spiders and small insects occasionally spin webs or make nests in the grill burner tubes during transit and warehousing.

These webs can lead to gas flow obstruction which could result in a fire in and around burner tubes. This type of fire is known as “FLASH-BACK” and can cause serious damage to your grill and create an unsafe operating condition for the user.

Although an obstructed burner tube is not the only cause of “FLASH-BACK”, it is the most common cause.

To reduce the chance of “FLASH-BACK”, you must clean the burner tubes before assembling your grill, and at least once a month in late summer or early fall when spiders are most active. Also perform this burner tube cleaning procedure if your grill has not been used for an extended period of time.

WHEN TO LOOK FOR SPIDERS

You should inspect the burners at least once a year or immediately after any of the following conditions occur:

1. The smell of gas in conjunction with the burner flames appearing yellow.
2. The grill does not reach temperature.
3. The grill heats unevenly.
4. The burners make popping noises.

BEFORE CALLING FOR SERVICE

If the grill does not function properly, use the following check list before contacting your dealer for service. You may save the cost of a service call.

TROUBLE SHOOTING

PREHEATING: The grill lid should be in a closed position during the preheat time period. It is necessary to preheat the grill for a short time before cooking certain foods, depending on the type of food and the cooking temperature. Food that requires a high cooking temperature needs a pre-heat period of five minutes; food that requires a lower cooking temperature needs only a period of two to three minutes. There is no need to preheat for casseroles or other foods that require slow cooking.

COOKING TEMPERATURES

High setting-Use this setting for fast warm-up, for searing steaks and chops, and for burning food residue from the cooking grids.

Medium setting-Use this setting for grilling, roasting or baking.

Low setting-Use this setting for all smoke cooking, and when cooking very lean cuts such as fish.

These temperatures vary with the outside temperature and the amount of wind.

Cooking with in-direct Heat: You can cook poultry and large cuts of meat slowly to perfection on one side of the grill by indirect heat from the burner on the other side. Heat from the lighted burner circulates gently throughout the grill, cooking the meat or poultry without any direct flame touching it. This method greatly reduces flare-ups when cooking extra fatty cuts, because there is no direct flame to light the fats and juices that drip down during cooking. Place a drip pan slightly smaller than the cut of meat on the flame tamer surface under the meat being cooked. This will allow you to catch meat juices for making gravy.

Flare-Ups: The fats and juices that drip from the meat cause flare-ups. Since flare-ups impart the distinctive taste and color for food cooked over an open flame, they should be expected and encouraged within reason.

Nevertheless, uncontrolled flaring can result in a ruined meal.

CAUTION: If burners go out during operation, close gas supply at source, and turn all gas valves off. Open lid and wait five minutes before attempting to re-light (this allows accumulated gas fumes to clear).

CAUTION: Should a grease fire occur, close gas supply at source, turn off all burners and leave lid closed until fire is out.

CAUTION: DO not attempt to disconnect any gas fitting while your barbecue is in operation. As with all appliances, proper care and maintenance will keep them in top operation condition and prolong their life. Your gas grill is no exception.

TROUBLE SHOOTING

- Cover may be incorrect for your grill. It may be a tight fit. Ensure the cover correct length for your grill. Measure it left to right. Compare to the grill's measurement.
- Compare the location and size of the hood portion of the cover to your grill.
- Spread the cover and allow it to relax, preferably in warm sunlight or in a warm room.

PROBLEM	SOLUTION
When I light the grill it does not flame immediately .	<ul style="list-style-type: none"> --Make sure you have turn on the gas --Make sure it has spark while you are trying to ignite the burner. --Push in for approximately 5 second before to turn and ignite the grill. --Make sure your burner is clean.
Rotisseries burner will not light when the igniter button is pushed.	<ul style="list-style-type: none"> --Check to see if debris is blocking the electrode sparks. --Check to see there is spark that jumps to the burner from the electrode wire. If no spark is seen. --Check the battery located inside the button. Press and turn counter clockwise. --Check for loose wire connection. --Gently bend the electrode wire closer to the burner until a spark is seen to jump from the igniter to the burner when you press the starter button. --Dose the infrared back burner light when attempting to match light? If not, check did you turn on the gas.
Regulator makes noise.	<ul style="list-style-type: none"> --Vent hose on the regulator may be plugged or regulator may be faulty. --Ensure the vent hole on the regulator is not obstructed. Clear the hole, close the gas control valves. Wait ten minutes and re-start. --Check your flames for proper performance if the flames are not correct replace regulator.
Full size cover does not fit the grill.	<ul style="list-style-type: none"> --Cover may be incorrect for your grill. It may be a tight fit. Ensure the cover correct length for your grill. Measure it left to right. Compare to the grill's measurement. --Compare the location and size of the hood portion of the cover to your grill. --Spread the cover and allow it to relax, preferably in warm sunlight or in a warm room. --For grill with a side shelf bunch the cover like a sock, put on left to right.

TROUBLE SHOOTING

<p>Rotisserie motor will not turn</p>	<ul style="list-style-type: none"> --Check the voltage at the outlet. --If an extension cord is required, ensure it is a 16 gauges, grounded cord. --Ensure the on/off switch is on. --Ensure the load does not exceed the 40 pounds operational capacity. --Ensure the spit is fully inserted in the motor. --Ensure there is no encumbrance or drag.
<p>Grill only heats to 200-300 degrees.</p>	<ul style="list-style-type: none"> --Ensure the temperature gauge is functioning properly. Hold a flame to the probe or compare the grill gauge to an oven thermometer place in the grill. --Ensure correct start procedure. Prior to lighting grill, the gas control knobs should be off. The propane bottle should be off. If not, wait 15 minutes. Turn tank all the way on.. Turn left burner to ignite, wait 5 seconds ignite. Repeat for additional burners. --Check all gas connections for leaks with bubble test. If leaks are found, replace the part or tighten the fitting. --If it is a natural gas grill, ensure there is proper pressure to the grill. Refer to the user manual. Example: Gas line stubbed off o pool heater may exhibit deference in pressure. .
<p>Grill takes a long time to preheat.</p>	<ul style="list-style-type: none"> --Normal preheat 500-600degrees, takes about 10-15 min. Cold weather and wind may effect your preheat time. --If you are using volcanic rock or briquettes they can increase the preheat time and maximum temperature.
<p>Burner flames are not light blue.</p>	<ul style="list-style-type: none"> --Too much or not enough air mixes for the flame. --Elevation is the principal cause, however cold weather can affect the mixture. Burner adjustment may be required. --Grill is in a windy location.

EXPLODED VIEW

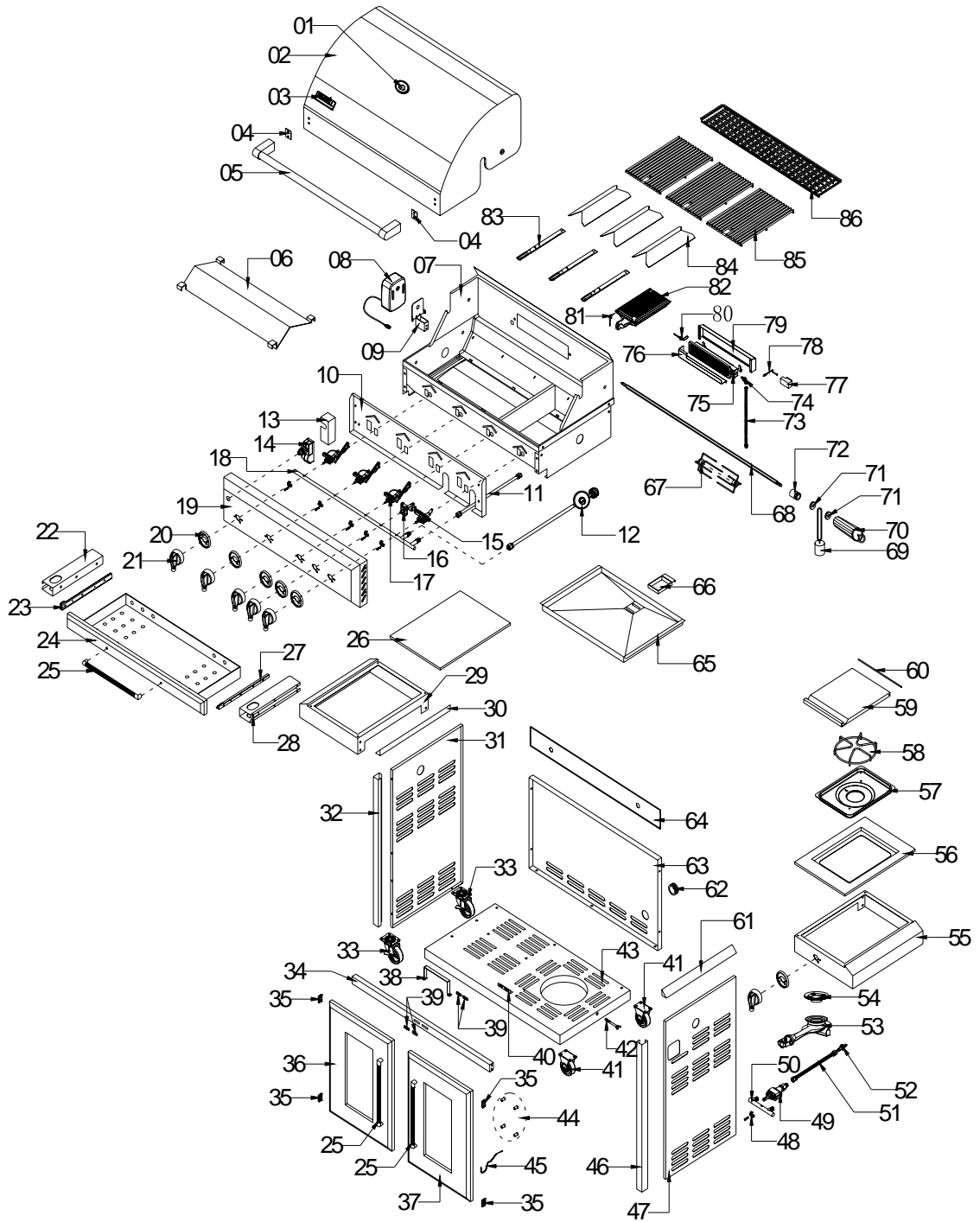

PARTS LIST

REF#	DESCRIPTION	QTY	REF#	DESCRIPTION	QTY
1	Main Lid	1	27	Utility Drawer Slide, Right	1
2	Main Lid Screw	2	28	Side Shelf, Left B	1
3	Main Lid Screw Cover	2	29	Side Shelf, Left A	1
4	Logo	1	30	Side Shelf Trim Panel,Left	1
5	Main Lid Handle Heat Insulating Spacer	2	31	Side Panel, Left	1
6	Temperature Gauge	1	32	Front Trim Panel, Left	1
7	Main Lid Handle	1	33	Swivel Caster with Brake	2
8	Grease Slide Panel, Top	1	34	Cart Frame , Front	1
9	Main Burner Bowl Assembly	1	35	Door Hinge	4
10	Rotisserie Motor	1	36	Front Door, Left	1
11	Rotisserie Motor Bracket	1	37	Front Door, Right	1
12	Front Baffle	1	38	Door Magnet	4
13	Pulse Igniter Module Cover	1	39	Door Magnet Bracket	1
14	Pulse Igniter Module	1	40	Swivel Caster	2
15	Sear Gas Valve	1	41	Bottom Panel, LP	1
16	Side Burner Hose	1	42	Tank Bolt	1
17	Rotisserie Gas Valve	1	43	Door Handle Plastic Insert	1
18	Main Gas Valve	3	44	Lighting Rod	1
19	Main Manifold	1	45	Front Trim Panel, Right	1
20	Main Control Panel	1	46	Side Panel, Right	1
21	Bezel	6	47	Gas Valve Clamp	6
22	Control Knob	6	48	Side Manifold	1
23	Utility Drawer Slide Bracket	2	49	Side Burner Gas Valve	1
24	Utility Drawer Slide, Left	1	50	Side Burner Flex Gas	1
25	Utility Drawer	1	51	Side Burner Orifice Brass Connector	1
26	Door and Utility Drawer Handle	3	52	Side Burner Pipe	1

PARTS LIST

REF#	DESCRIPTION	QTY	REF#	DESCRIPTION	QTY
53	Side Burner Ring	1	71	Rotisserie Handle	1
54	Side Burner Igniter wire	1	72	Key Washer	2
55	Side Burner bowl Assembly Frame A	1	73	Shaft Collar	1
56	Side Burner Bowl Assembly Frame B	1	74	Rotisserie Burner Flex Gas	1
57	Side Burner Bowl Assembly Fire Box	1	75	Rotisserie Orifice w/Brass Elbow	1
58	Side Burner Cooking Grate	1	76	Rear Baffle	1
59	Side Burner Lid	1	77	Rotisserie Burner	1
60	Side Burner Lid Hinge Rod	1	78	Rotisserie Burner Thermocouple Bracket	1
61	Side Shelf Trim Panel, Right	1	79	Rotisserie Burner Thermocouple	1
62	Rubber Grommet	1	80	Rotisserie Burner Igniter Wire	1
63	Back Panel	1	81	Sear Burner Igniter Wire	1
64	Back Panel, Top	1	82	Sear Burner	1
65	Regulator, LP	1	83	Sear Burner Thermocouple Bracket	1
66	Grease Slide Panel, Bottom	1	84	Sear Burner Thermocouple	1
67	Grease Tray	1	85	Main Burner	3
68	Spit Fork	2	86	Flame Tamer	3
69	Spit Rod	1	87	Cooking Grid with Hole	3
70	Counter-Balance	1	88	Warming Rack	1

ORDERING PARTS

HOW TO ORDER REPLACEMENT PARTS

To make sure you obtain the correct replacement part(s) for your gas grill, please refer to the parts list on page 24. The following information is required to assure getting the correct part.

- Gas grills model number (see data sticker on grill).
- Part number of replacement part needed.
- Description of replacement part needed.
- Quantity of parts needed.

To obtain replacement parts, contact customer service 1-866-984-7455.

IMPORTANT

Use only factory authorized parts. The use of any part that is not factory authorized can be dangerous. This will also void your warranty.

Keep this assembly and operating instruction manual for convenient referral, and for replacement parts ordering.

CAUTION

Gas valves are stocked at the factory (valve assembly will be marked accordingly). If you wish to convert at some later date, be sure to contact your gas supplier or grill dealer before making the conversion.

Different orifices must be installed when converting from one type of gas to another. You will also need a data plate indicating what type of gas is used by the grill.

GRILL HINTS

The doneness of meat, whether rare, medium, or well done, is affected to a large degree by the thickness of the cut. Expert chefs say it is impossible to have a rare doneness with a thin cut of meat.

The cooking time is affected by the kind of meat, the size and shape of the cut, the temperature of the meat when cooking begins, and the degree of doneness desired.

When defrosting meats it is recommended that it be done overnight in the refrigerator as opposed to a microwave. This in general yields a juicier cut of meat.

Use a spatula instead of tongs or a fork to

turn the meat, as a spatula will not puncture the meat and let the juices run out.

To get the juiciest meats, add seasoning or salt after the cooking is finished on each side and turn the meat only once (juices are lost when the meat is turned several times). Turn the meat just after the juices begin to bubble to the surface.

Trim any excess fat from the meat before cooking. To prevent steaks or chops from curling during cooking, slit the fat around the edges at 2-inch intervals.

DO NOT LEAVE THE GRILL UNATTENDED WHILE COOKING.

GRILL COOKING CHART

FOOD	WEIGHT OR THICKNESS	FLAME SIZE	APPROXIMATE TIME	SPECIAL INSTRUCTIONS AND TIPS
VEGETABLES				
Fresh				Slice.Dot with butter or margarine Wrap in heavy-duty foil.Grill,turning occasionally
Beets		Medium	12 to 20 minutes	
Carrots				
Turnips				Grill,turning once.Brush Occasionally With melted butter or margarine
Onion	1/2 inch slices	Medium	8 to 20 minutes	
Potatoes				Wrap individually in heavy-Duty foil.Grill,rotating Occasionally.
Sweet	Whole	Medium	40 to 60 minutes	
White	6 To 8 ounces	High	45 to 60 minutes	
Frozen				Dot with butter or margarine Wrap in heavy-duty foil.Grill Turning occasionally
Asparagus		Medium	15 to 30 minutes	
Broccoli				
Brussels				
Sprouts				
Green beans				
Peas				
French fries		Medium	15 to 30 minutes	Place in aluminum foil pan. Grill, stirring occasionally.
MEATS				
Beef				
Hamburgers	1/2 to 3/4inch	Medium	10 to 18 minutes	Grill,turning once when juices rise to the surface Do not leave hamburgers unattended since a flare-up could occur quickly
		High	8 to 15 minutes	
Steaks				
Rib eye,				

GRILL COOKING CHART

FOOD	WEIGHT OR	FLAME SIZE	APPROXIMATE	SPECIAL INSTRUCTIONS AND TIPS
	THICKNESS		TIME	
Tenderloin, Porterhouse, T-Bone, Sirloin				
Rare	1 inch	High	8 to 14 minutes	Remove excess fat from edge. Slash remaining fat at 2-inch intervals. Grill, turning once.
	1-1/2 inch	High	11 to 18 minutes	
Medium	1 inch	Medium to	12 to 22 minutes	
	1-1/2 inch	High	16 to 27 minutes	
Well-done	1 inch	Medium	18 to 30 minutes	
	1-1/2 inches	Medium	16 to 35 minutes	
Lamb Chops & Steaks				
Rare	1 inch	High	10 to 15 minutes	Remove excess fat from edge. Slash remaining fat at 2-inch intervals. Grill, turning once.
	1-1/2 inch	High	14 to 18 minutes	
Medium	1 inch	Medium to	13 to 20 minutes	
	1-1/2 inch	High	18 to 25 minutes	
Well-done	1 inch	Medium	17 to 30 minutes	
pork Chops	1 inch	Medium	20 to 30 minutes	remaining fat at 2-inch intervals. Grill, turning once. Cook well done.
Well-done	1-1/2 inches	Medium	30 to 40 minutes	
Ribs		Medium	30 to 40 minutes	Grill, turning occasionally. During last few minutes brush with barbecue sauce, turn several times.
Pork Ham steaks				
(precooked)	1/2 inch slices	High	4 to 8 minutes	Remove excess fat from edge. Grill, turning once.
Hot dogs		Medium	5 to 10 minutes	Slit skin. Grill, turning once.
POULTRY				
Broiler/fryer	2 to 3 pounds	Low or	1 to 1-1/2 hours	brushing frequently marinade.
Halved or done		Medium	40 to 60 minutes	
Breasts well-done		Medium	30 to 45 minutes	

GRILL COOKING CHART

FOOD	WEIGHT OR THICKNESS	FLAME SIZE	APPROXIMATE TIME	SPECIAL INSTRUCTIONS AND TIPS
FISH AND SEAFOOD				
Steaks				Grill, turning once. Brush with melted butter, margarine or oil To keep moist.
Halibut	3/4 to 1 inch	Medium to	8 to 15 minutes	
Salmon		High		
Swordfish				
Whole				
Catfish 4 to 8 ounces	4 to 8 ounces	Medium to	12 to 20 minutes	Grill turning once. Brush with Melted Butter, margarine or oil.
Rainbow trout		High		

GRILL RECIPE SUGGESTIONS

BBQ SALMON

2 large salmon steaks
2 tbs. Oil
Salt & pepper
2 oz. thin bacon slices
2 tbs. Butter
1 tbs. Lemon juice
Spring of parsley
Lemon wedges

Preheat the BBQ.

Brush the steaks with oil and season with salt and pepper. Place on BBQ grill and cook for 10 minutes, turning steaks over halfway cooking time.

Meanwhile fry the bacon in a pan on the side burner. Drain on paper towels. Meld the butter in a small saucepan taking care not to discolor it. Arrange the fish and bacon on serving plates. Pour the butter over and sprinkle with lemon juice. Garnish with parsley springs and lemon wedges. Serve with boiled potatoes tossed in butter and sprinkled with chopped parsley and a crisp lettuce salad.

Note: Substitute catfish, halibut or cod for salmon.

BAKED CHILI CORN

6 medium ears corn, husked
3 tbs. Butter or margarine, melted
Dash ground cumin
Dash ground coriander

About ½ hour before cooking, turn the butter on for grill. Place each corn on a heavy-duty foil. In a bowl, combine remaining ingredients. Mix well. Brush 1-1/2 tsp. Butter mixture over each ear. Close foil and fold up ends to seal. Place on grill. Cook, turning packets occasionally 10 to 12 minutes or until cooked through.

TANGY SEAFOOD KABOBS

1 lb. Large shrimp, shelled & deveined
¾ lbs. sea scallops
2/3 c. chili sauce
¼ c. cider vinegar

butter and sprinkled with chopped parsley and a crisp lettuce salad.

In medium bowl, combine shrimp and scallops. In small bowl combine chili sauce and next six ingredients. Pour over seafood. Toss to coat. Cover, refrigerate 2 hours.

Note: Substitute catfish, halibut or cod for salmon.

PORK CHOPS

4 Pork chops
Marinade
1 large onion
2 tbs. lemon juice or vinegar
2 tbs. oil
½ tsp. powdered mustard
2 tsp. Worcestershire sauce
½ tsp. freshly ground black pepper
1 tsp. sugar
½ tsp. paprika
1 clove garlic

Peel, grate onion, and add rest of the ingredients except the pork chops. Mix well. Pour over chops and marinate one hour in a cool place. Turn the BBQ grill on full. Heat 10 minutes. BBQ the chops brushing with the marinade occasionally. Serve with mixed salad, dressed with vinaigrette flavored with fresh dill.

3 tbs. chopped parsley
1 tbs. vegetable oil
1 tbs. Worcestershire sauce
½ tsp. prepared horseradish
1 cove garlic, minced
1 20 oz. Can pineapple chunks in juice, drained

Half hour before cooking, turn the burner to the grill on full. Drain seafood reserving marinade. On each of twelve 10" skewers, thread 2 shrimps and 2 scallops, alternating with pineapple chunks. Place skewers on grill. Cook 7-10 minutes, often basting and turning.

BARBECUED LONDON BROIL

4 to 6 servings
¾ c. Italian dressing
1 tsp. Worcestershire sauce
1 tsp. dry mustard
¼ tsp. thyme, crushed
1 medium onion, sliced
1 pound flank steak, scored
2 tbs. butter, melted

Combine first 4 ingredients, add onion and marinade flank steak with it. Refrigerate at least 4 hours or overnight. Remove steak and grill on your preheated BBQ grill. Grill 5 to 7 minutes on each side basting frequently with the marinade. In the meantime sauté onions from the marinade in butter in a skillet on your side burner for 3 minutes. To serve, slice steak diagonally into thin slices, sprinkle onions over top. Garnish with vegetable kabobs.

BARBECUED POTATOES and CHEESE

1-1/2 cups shredded cheddar cheese
1 can (10-3/4 oz.) condensed cream of mushroom soup
1/3 cup milk
2 tbs. barbecue sauce
¼ tsp. oregano
¼ tsp. salt
1/8 tsp. pepper
4 cups thinly sliced potatoes (4 medium-sized potatoes)

GRILL RECIPE SUGGESTIONS

Preheat grill. Combine cheese, condensed soup, milk, BBQ sauce, oregano, salt and pepper in a large mixing bowl. Stir in potatoes until well coated. Turn into well buttered 1-1/2 quart rectangular baking dish. Cover dish with aluminum foil. Bake covered 25 minutes on medium with the lid of your BBQ grill closed. Remove foil and continue baking 15 minutes longer or until potatoes are tender. Let stand 5 minutes before serving.

VEGETABLE KABOBS

3 medium-sized zucchini
12 cherry tomatoes
12 fresh mushrooms
Grated Parmesan cheese

Parboil whole zucchini 5 minutes on your side burner or until just tender. Drain and cut into 1/2 inch slices. Thread zucchini, tomatoes and mushrooms alternately on each of six skewers. Brush with marinade made of Italian dressing, Worcestershire sauce, mustard and thyme. Grill 5 to 7 minutes turning and basting occasionally. Sprinkle liberally with Parmesan cheese.

FAJITAS

1-1/2 lb. flank steak or boned chicken breasts
2 tbs. oil
1/2 cup lime juice
1/2 tsp. salt
1/2 tsp. celery salt
1/4 tsp. garlic powder
1/2 tsp. pepper
1/4 tsp. oregano
1/4 tsp. cumin
Flour tortillas lemon

Pound flank steak to 1/4 inch thickness or flatten chicken breasts. Mix oil, lime juice and seasonings in a zip lock bag. Add meat and shake bag to coat the meat. Refrigerate overnight or at least 6 to 8 hours. Wrap tortillas in foil. Remove meat from marinade. Cook on a pre-heated gas grill for 5 to 8 minutes on each side. While meat is cooking, heat tortillas on grill. Slice meat across grain in thin slices. Place on hot platter. Squeeze lemon juice over. Wrap meat and any of the following toppings in tortillas: chopped tomatoes, guacamole, sour cream, taco sauce.

BEEF AND LAMB KABOBS

Serve 4

1/2 lb. boneless sirloin or beef cut into 1" cubes
1/2 lb. boneless loin of lamb cut into 1" cubes
2/3 c. water, divided
1/4 c. chopped onion
2 tbs. soy sauce
1/4 c. vegetable oil, divided
1 tbs. dark brown sugar
1 tbs. fresh lemon juice
2 cloves garlic, minced
1/4 tsp. ground cumin
1/4 tsp. ground coriander
1/4 tsp. ground turmeric
1/8 tsp. ground red pepper
1/8 tsp. ground ginger
1 red pepper cut into chunks
1 large banana, cut into chunks
8 small mushrooms
1/3 c. smooth peanut butter

In blender, process 1/3 c. water, onion, soy sauce, 2 tsp. oil and the next 8 ingredients until smooth. Pour over meat cubes and marinate about 4 hours, turning occasionally. Drain and reserve marinade. Onto to four 12" skewers alternately thread meat, pepper, banana and mushrooms. Preheat grill. Brush the kabobs with oil. Grill 7-8 minutes each side.

Bring marinade to boil on the side burner in a saucepan. Add remaining 1/3 c. water and peanut butter. Stir to blend. Heat through. If sauce gets too thick, add 1 tbs. water. Serve sauce with kabobs.

EGGPLANT CAVIAR

1 large eggplant
2 tbs. olive oil
2 tbs. wine vinegar
2 tbs. finely chopped onion
1/2 clove garlic, minced
1 medium tomato, chopped salt and pepper

Roast eggplant on gas grill over medium flame, turning occasionally until thoroughly cooked. This may take 30 minutes. Remove from grill and cool for handling. Strip off the skin and chop eggplant finely. Add all the seasonings. Chill thoroughly and serve on toast.

GRILL RECIPE SUGGESTIONS

CHICKEN TANDOORI STYLE

8 large chicken thighs or drumsticks

1 c. plain nonfat yogurt

½ c. lemon juice

2 tsp. salt

½ tsp. cayenne

½ tsp. black pepper

½ tsp. crushed garlic

½ tsp. grated ginger

1 tbs. corn oil

Combine all the ingredients in a large mixing bowl and marinate the chicken for 8 hours in the refrigerator. Drain the chicken and spread on the spit running the rod on the fleshier side of the bone.

Rotis using the rotisserie burner. Cook on medium high heat for 40 minutes basting occasionally with the remainder of the marinade mixture. Serve with sliced onions and lemon wedges.

SPARE RIBS

Marinade:

1 c. soy sauce

½ c. honey

½ c. vinegar

½ c. dry sherry

2 tsp. chopped garlic

2 tsp. sugar

1 c. water

1 chicken bouillon cube

1 can beer for basting sauce

Marinate ribs for 3 hours. Use marinade for basting by adding beer to it. Place pan under the ribs and baste frequently. To cook ribs select lean, meaty ribs and accordion pleat them with your spit. Slide four prong meat hook down the length of spit and tighten. At the beginning of

the rack and to its center, penetrate the second rib with the pointed end of the spit and push it between the meat. Skip a couple and continue the process until the entire rack is accordion pleated. Fasten the second meat hook into the rack. Turn your rotisserie burner on high. Rotis for 50 minutes or until done.

PORK ROAST

Apple cider vinegar basting sauce:

1 c. apple cider vinegar

6 oz. water

½ stick butter

Salt, pepper, parsley and garlic seasoning

2 oz. lemon juice

10 lbs. pork roast

Time: 1-1/2 hours to 2 hours

Bring pork to room temperature before placing it on the spit rod. Place on the rod and test for balance. Light rotis burner. Turn control knob to high. Use the above basting sauce for rotissing.

TURKEY

12 lb. turkey

Beer basting sauce:

1 can beer

12 oz. water

1 stick butter

1 tsp. salt

1 tsp. pepper

½ tsp. garlic flakes

1 tsp. parsley

Thaw the bird completely. Wash inside out. Securely tie the legs and wings. Light rotisserie burner. Turn to high. Combine all the ingredients for basting sauce in a shallow pan. Place it under the turkey 15 to 20 minutes. Cook for approximately 3 hours. The basting sauce combined with turkey drippings makes a delicious gravy.

CONVERTING TO NATURAL GAS

This Grill is portable and configured for use with Liquid Propane (LP Gas), which is delivered to the grill from removable tanks (LP tanks and their use are covered elsewhere in this manual). If a Natural Gas connection is available, the user may wish to change the gas delivery system to the more permanent Natural Gas supply.

This grill is certified for use with either Liquid Propane (LP Gas) or Natural Gas and comes complete with the necessary parts to convert it for use with Natural Gas. The Nexgrill patented Conversion Valves allows the use of Natural Gas without replacing the burners or entire valve system.

Additional parts needed are a Natural Gas Supply Hose and Regulator Valve (if necessary).

The process of converting is relatively simple and can be accomplished by any handy homeowner. Nexgrill suggests, however, that a qualified gas technician do the conversion. Your warranty may be voided if the conversion is improperly completed. Please retain the parts supplied with the grill and these instructions so the technician can do the conversion.

At any time the Grill may be re-converted back to Liquid Propane (LP Gas) by reversing the procedures outlined below.

CONVERTING TO NATURAL GAS

This grill is portable and configured for use with Liquid Propane (LP Gas), which is delivered to the grill from removable tanks (LP tanks and their use are covered elsewhere in this manual). If a Natural Gas connection is available, the user may wish to change the gas delivery system to the more permanent Natural Gas supply.

This grill is certified for use with either Liquid Propane (LP Gas) or Natural Gas and comes complete with the necessary parts to convert it for use with Natural Gas. The Nexgrill patented Conversion Valves allows the use of Natural Gas without replacing the burners or entire valve system.

Additional parts needed are a Natural Gas Supply Hose and Regulator Valve (if necessary).

The process of converting is relatively simple and can be accomplished by any handy homeowner. Nexgrill suggests, however, that a qualified gas technician do the conversion. Your warranty may be voided if the conversion is improperly completed. Please retain the parts supplied with the grill and these instructions so the technician can do the conversion.

Orifice Chart

The different burner valves in this grill have different BTU ratings. This means that the quantity of gas coming from each orifice varies in order to create the BTU's. The holes in the orifices themselves are drilled to different sizes so as to allow the proper amount of gas to flow through them. Please note the chart below to give an easy reference for the various orifice opening sizes for the different valves in the grill.

720/730-0439				
	LP		NG	
Components	Orifice Size	BTU	Orifice Size	BTU
Main Burner	1.55	10,000	0.94	10,000
Side Burner	1.7	12,000	1.02	12,000
Rear Burner	1.55	10,000	1.15	10,000
Sear Burner	1.9	15,000	0.94	15,000

INSTRUCTIONS FOR CONVERTING TO NATURAL GAS

Tools required for converting from LP to NG



- Screwdriver + is used for removing the screws
- 8mm Nut Driver is used for changing the main tube burner orifice
- Screwdriver - is used for turning the Low/High Flame
- 14mm Wrench is used for releasing the brass adapter of flex tube
- 10mm Wrench is used for changing the rear burner orifice
- Allen Key is used for removing the control knobs



- 18mm Wrench is used for fixing the side burner orifice nut (Included in package)
- 6.1mm Wrench is used for changing the side burner orifice (Included in package)



- Adjustable Wrench



- Side Burner Orifice (Included in package)
- Rear Burner Orifice (Included in package)
- Main Burner Orifice (Included in package)

GAS CONVERSION

Main Tube Burner Conversion

Steps

1. Remove the rotisserie kit, warming rack, cooking grids, flame tamers and tube burners from the firebox.



2. Locate orifice on end of valve and remove by turning counterclockwise with a 8mm Nut Driver.

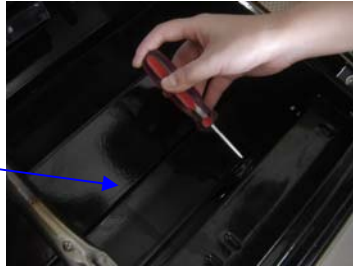
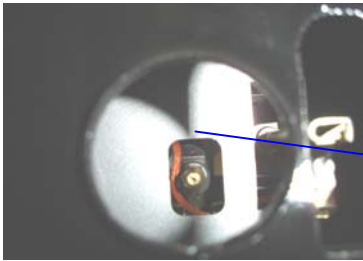

CAUTION!

When converting the grill, screw the orifice in and out of the stem gently due to the breakable thread.

3. Insert NG orifice and screw in tightly.



4. Replace tube burners back.



GAS CONVERSION

Side Burner Conversion

Steps

1. Fix orifice nut with 18mm Wrench. Then locate orifice and remove by turning counterclockwise with 6.1mm Wrench.

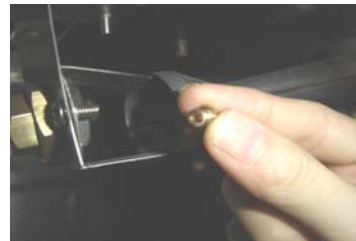

2. Insert NG orifice by hand, then secure and turning clockwise with 6.1mm Wrench in tightly.



GAS CONVERSION

Rear Burner Conversion

Steps

1. Remove the eight screws securing the rear baffle. Then take out the Rear Baffle.



2. Locate rotisserie orifice and remove by turning counterclockwise with a 10mm Wrench.



3. Attach and screw in tightly the NG rotisserie orifice.



4. Replace the Rear Baffle back.

GAS CONVERSION

For Main tube burner and Side burner Conversion Only

You will need to adjust the High Flame setting screw when converting the barbecue from Propane to Natural Gas. Please follow the steps as detailed below

1. Remove each Control Knob of main tube burners and side burner by loosening the socket head grub screw holding it to the Valve stem.
2. Turn the valve to the IGNITE/HI position on the Control panel and then use a screwdriver to turn the High Flame Set Screw approximately $\frac{1}{2}$ a turn counterclockwise.
3. Check that burner operates at the new high fire setting - it may be necessary to adjust the screw setting slightly to get the ideal burner flame height.



GAS CONVERSION

NG Hose and Regulator Conversion

1. Turn all knobs to OFF, and turn off LP supply, then take off the brass adapter of LP regulator from the manifold with a wrench.



2. Attach the NG regulator to the manifold, and screw tightly with the wrench.



3. Remove NG regulator bracket by unscrew the four 5/32*10mm screws on the right shelf panel and then tight the NG regulator on the NG regulator bracket with two 5/32*10mm screws.

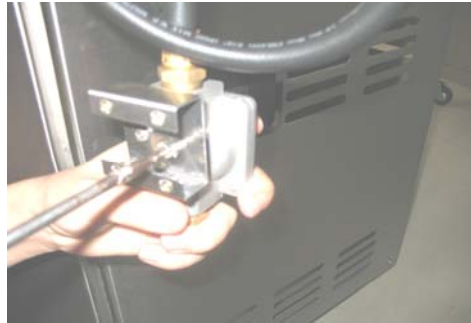

4. Put back the NG regulator bracket back by screw back four 5/32*10mm screws on the right shelf panel and connect the 12' NG hose to the NG regulator with the wrench.



LIMITED WARRANTY

LIMITED WARRANTY

MODEL 720-0439

STAINLESS STEEL OUTDOOR GAS GRILL

Nexgrill Industries, Inc. warrants to the original consumer purchaser of each Outdoor Gas Grill that when subject to normal residential use, it is free from defects in workmanship and materials for the periods specified below. This warranty excludes grills used in rental or commercial applications. There will be a shipping and handling charge for the delivery of the warranty part(s).

Component	Warranty Period
Grill Rods:	3 Years
Cart Frame:	3 Years
Grill Lid:	3 Years
Control Panel Housing:	3 Years
Side Shelves :	3 Years
Stainless Steel Burners:	5 Years
Rear Burner:	3 Years
Valves and Knobs:	1 Year
Ignition System:	1 Year
Gas Supply System:	1 Year
Casters:	1 Year
Temperature Gauge	1 Year
PVC Cover	1 Year

Our obligation under this warranty is limited to repair or replacement, at our option, of the product during the warranty period. The extent of any liability of Nexgrill Industries, Inc. under this warranty is limited to repair or replacement. This warranty does not cover normal wear of parts, damage resulting from any of the following: negligent use or misuse of the product, use on improper fuel/gas supply, use contrary to operating instructions, or alteration by any person other than our factory service center. The warranty period is not extended by such repair or replacement.

Warranty claim procedure: If you require service or parts for your grill, please contact our Warranty Service Center for factory direct assistance. Our hours of operation are 8 AM to 5 PM PST. Our number is 866-984-7455 and our FAX number is 1-909-598-7699. Please direct all correspondence to: ATTN: Warranty Service Center.

Product repair as provided under this warranty is your exclusive remedy. Nexgrill Industries, Inc. shall not be liable for any incidental or consequential damages for breach of any express or implied warranty on its products. Except to the extent prohibited by applicable law, any implied warranty or merchantability or fitness for a particular purpose on this product to the duration of the above warranty. Some states do not allow the exclusion or limitation of incidental or consequential damages, or allow limitations on how long an implied warranty lasts, so the above limitations or exclusions may not apply to you. This warranty gives you specific legal rights, and you may have other rights, which vary from state to state.

Manufactured by: Nexgrill Industries, Inc. 280 Machlin Court, City of Industry, CA 91789

Please register your product online at:

www.NEXGRILL.com

(If you register online, you do not need to send in this registration card.)

Please fill out this card and return it within 10 days of purchase to accommodate customer and service inquiries to the manufacturer. Failure to return the card may delay response time and/or complicate response to customer inquiries. Remember to keep your sales receipt. The warranty is non-transferable. Customers should include a copy of their original sales receipt as proof of purchase. The receipt should be mailed along with the registration card; or mailed after the online registration is completed, along with a printed confirmation.

Llene por favor esta tarjeta y lo vuelve dentro de 10 días de la compra a acomodar las indagaciones de cliente y servicio al fabricante. El fracaso para volver la tarjeta puede demorar el tiempo de respuesta y/o complicar la respuesta a indagaciones de cliente. Recuerde de mantener su recibo de ventas. La garantía es intransferible. Los clientes deben incluir una copia de su recibo original de ventas como comprobante de compra. El recibo debe ser enviado junto con la tarjeta de matrícula; o enviado después de que la matrícula en el internet sea competida, junto con una confirmación impresa.

Veuillez remplir cette carte et la renvoyer dans les dix jours après votre achat à l'attention du service clientèle et réclamations du fabricant. Ne pas renvoyer la carte pourrait retarder ou compliquer la procédure lors de toute réclamation. N'oubliez pas de garder votre ticket de caisse lors de l'achat. La garantie est non transférable. Le client doit joindre une copie de son ticket de caisse original comme preuve d'achat. Le ticket doit être renvoyé avec la carte de garantie; ou après l'enregistrement complété en ligne sur internet, de pair avec une copie imprimée de la confirmation.

1 First Name/Nombre/Prénom Initial/Inicial/Initiale Last Name/Apellido/Nom de famille

Address (number and street)/Dirección (número y calle)/Adresse (numéro et rue) Apt Number/Nº de apart./Nº d'apprt.

City/Ciudad/Ville State/Estado/Province Zip Code/Código zip/Code postal

2 E-mail Address/Dirección de correo electrónico/Adresse électronique
*If you voluntarily provide us with your email address, you give us permission to use your email address to send you offers that may interest you.
Si nos informa voluntariamente su dirección de correo electrónico, nos da permiso para usarlo a fin de enviarle ofertas que pueden interesarle.
Si vous choisissez de nous fournir votre adresse électronique, vous nous donnez la permission de l'utiliser pour vous faire part d'offres spéciales susceptibles de vous intéresser.*

(Example: your name@your host.com) (Ejemplo: su nombre@su host.com) (Exemple: votre nom@votre hôte.com)

3 Phone Number/Número telefónico/Numéro de téléphone

4 IMPORTANT! ¡IMPORTANTE! IMPORTANT!
*Write Serial Number and Model Number in spaces below.
Escribe en los espacios de abajo el número de serie y el número de modelo.
Inscrivez le numéro de série et le numéro de modèle dans les espaces ci-dessous.*

5 Date of Purchase/Fecha de compra/Date de l'achat

6 Store Name/Nombre de la tienda/Nom du magasin

7 Purchase Price/Precio de compra/Prix d'achat

\$ _____ .00

Mail to:/Envíelo a:
Warranty Registration Department
280 Machlin Ct
City of Industry, CA 91789