

MAN0064

(Rev. 05/18/2010)



WOODS

111877
LOADER MOUNTING KIT
for 1020, 1027, LU126 Loaders

on Ford/New Holland®
2000, 2310, 2600, 2610
2810, 2910, 3000, 3600
3610, 3910, 4000SU, 4100
4600SU, 4610SU, Tractors

includes Hose Kits
57923, 1001420
1023582, 1023596

WOODS®
Tested. Proven. Unbeatable.

INSTALLATION MANUAL

TO THE DEALER:

Assembly and proper installation of this product is the responsibility of the Woods® dealer. Read manual instructions and safety rules. Make sure all items on the Dealer's Pre-Delivery and Delivery Check Lists in the Loader Operator's Manual are completed before releasing equipment to the owner.

TO THE OWNER:

Read this manual and Loader Operator's Manual before operating your Woods equipment. The information presented will prepare you to do a better and safer job. Keep this manual handy for ready reference. Require all operators to read this manual carefully and become acquainted with all adjustment and operating procedures before attempting to operate. Replacement manuals can be obtained from your dealer. To locate your nearest dealer, check the Dealer Locator at www.WoodsEquipment.com, or in the United States and Canada call 1-800-319-6637.

The equipment you have purchased has been carefully engineered and manufactured to provide dependable and satisfactory use. Like all mechanical products, it will require cleaning and upkeep. Lubricate the unit as specified. Observe all safety information in this manual and safety decals on the equipment.

For service, your authorized Woods dealer has trained mechanics, genuine Woods service parts, and the necessary tools and equipment to handle all your needs.

Use only genuine Woods service parts. Substitute parts will void the warranty and may not meet standards required for safe and satisfactory operation. Record the model number of your equipment in the space provided.

Model: _____

Date of Purchase: _____

Provide this information to your dealer to obtain correct repair parts.

Throughout this manual, the term **NOTICE** is used to indicate that failure to observe can cause damage to equipment. The terms **CAUTION**, **WARNING**, and **DANGER** are used in conjunction with the Safety-Alert Symbol (a triangle with an exclamation mark) to indicate the degree of hazard for items of personal safety.



This is the safety alert symbol. It is used to alert you to potential personal injury hazards. Obey all safety messages that follow this symbol to avoid possible injury or death.



Indicates a hazardous situation which, if not avoided, will result in death or serious injury.



Indicates a hazardous situation which, if not avoided, could result in death or serious injury.



Indicates a hazardous situation which, if not avoided, could result in minor or moderate injury.

**IMPORTANT
or NOTICE**

Is used to address practices not related to personal injury.

NOTE

Indicates helpful information.

WOODS®

ALITEC™
BMP®
CENTRAL FABRICATORS®
GANNON®
GILL®
WAIN-ROY®
WOODS®

2 Introduction

LMK (Rev. 7/20/2007)



SAFETY RULES

ATTENTION! BECOME ALERT! YOUR SAFETY IS INVOLVED!



¡LEA EL INSTRUCTIVO!

Si no lee Ingles, pida ayuda a alguien que si lo lea para que le traduzca las medidas de seguridad.

Safety is a primary concern in the design and manufacture of our products. Unfortunately, our efforts to provide safe equipment can be wiped out by an operator's single careless act.

In addition to the design and configuration of equipment, hazard control and accident prevention are dependent upon the awareness, concern, judgement, and proper training of personnel involved in the operation, transport, maintenance, and storage of equipment.

It has been said, "The best safety device is an informed, careful operator." We ask you to be that kind of operator.

INSTALLATION

- This Loader Mounting Kit is to be used only for the loaders and tractors specified in this manual. Any other use or modification of this mounting kit may result in serious injury or death.
- Hydraulics must be connected as instructed in this manual. Do not substitute parts, modify, or connect in any other way.
- After connecting hoses, check that all control lever positions function as instructed in the Operator's Manual. Do not put into service until control lever and equipment movements are correct.
- Safety instructions are important! Read all attachment and power unit manuals; follow all safety rules and safety decal information. (Replacement manuals and safety decals are available from your dealer. To locate your nearest dealer, check the Dealer Locator at www.WoodsEquipment.com, or in the United States and Canada call 1-800-319-6637.) Failure to follow instructions or safety rules can result in serious injury or death.
- Keep hands and body away from pressurized lines. Use paper or cardboard, not hands or other body parts to check for leaks. Wear safety goggles. Hydraulic fluid under pressure can easily penetrate skin and will cause serious injury or death.
- Make sure that all operating and service personnel know that if hydraulic fluid penetrates skin, it

must be surgically removed as soon as possible by a doctor familiar with this form of injury or gangrene, serious injury, or death will result. **CONTACT A PHYSICIAN IMMEDIATELY IF FLUID ENTERS SKIN OR EYES. DO NOT DELAY.**

- Check that all hardware is properly installed. Always tighten to torque chart specifications unless instructed otherwise in this manual.
- Air in hydraulic systems can cause erratic operation and allows loads or equipment components to drop unexpectedly. When connecting equipment or hoses or performing any hydraulic maintenance, purge any air in hydraulic system by operating all hydraulic functions several times. Do this before putting into service or allowing anyone to approach the equipment.
- Protective hose sleeves must cover all hydraulic hoses within 20 inches of the operator and be secured onto metal hose fittings. Replace hoses or sleeves if damaged or if protective sleeve cannot be properly positioned or secured.
- Make sure all hydraulic hoses, fittings, and valves are in good condition and not leaking before starting power unit or using equipment. Check and route hoses carefully to prevent damage. Hoses must not be twisted, bent sharply, kinked, frayed, pinched, or come into contact with any moving parts. Operate moveable components through full operational range to check clearances. Replace any damaged hoses immediately.
- Always wear relatively tight and belted clothing to avoid getting caught in moving parts. Wear sturdy, rough-soled work shoes and protective equipment for eyes, hair, hands, hearing, and head; and respirator or filter mask where appropriate.
- Do not modify or alter or permit anyone else to modify or alter the equipment or any of its components in any way.
- Do not allow bystanders in the area when operating, attaching, removing, assembling, or servicing equipment.
- Use a suitable lifting device of sufficient capacity. Use adequate personnel to handle heavy components.
- Keep all persons away from operator control area while performing adjustments, service, or maintenance.

LOADER MOUNT INSTALLATION

WARNING

■ Only use 111877 Loader Mounting Kit for mounting Woods 1020, 1027, LU126 loaders on Ford New Holland 2000, 2310, 2600, 2610, 2810, 2910, 3000, 3600, 3610, 3910, 4000SU, 4100, 4600SU, and 4610SU tractors. Any other use or modification of this mounting kit may result in serious injury or death.

■ Safety instructions are important! Read all attachment and power unit manuals; follow all safety rules and safety decal information. (Replacement manuals and safety decals are available from your dealer. To locate your nearest dealer, check the Dealer Locator at www.WoodsEquipment.com, or in the United States and Canada call 1-800-319-6637.) Failure to follow instructions or safety rules can result in serious injury or death.

CAUTION

■ Always wear relatively tight and belted clothing to avoid getting caught in moving parts. Wear sturdy, rough-soled work shoes and protective equipment for eyes, hair, hands, hearing, and head; and respirator or filter mask where appropriate.

NOTICE

■ This equipment must be assembled and installed on the customer's tractor by the Woods dealer. Dealer must thoroughly inspect equipment and complete each item on the PRE-DELIVERY CHECK LIST, DELIVERY CHECK LIST, and PRODUCT REGISTRATION before equipment is released to the customer.

■ Clean threaded holes in the tractor chassis thoroughly using a tap of the proper size. Paint, rust, or debris in the threads may not permit cap screws to be installed and tightened correctly.

TRACTOR PREPARATION

For installing this mounting kit, references to right, left, forward, and rearward directions are determined from the operator's position in the tractor seat.

NOTE: Leave all loader mount hardware loose until mount is completely installed or otherwise instructed.

1. Shut off engine and set parking brake during installation.
2. Remove the tractor front weights and weight bracket if equipped.
3. Set tractor front wheel width to 61-1/2" (center line of thread) as instructed in tractor operator manual.
4. Remove cowl-mounted headlights if equipped.

As a valued customer, Woods appreciates your comments. Once loader mount and hydraulic hoses have been installed, please take a few minutes to complete the Loader Mount Evaluation sheet that was supplied with your loader mount. Your comments will help us continue to bring you quality products.

Install Right and Left Rear Mounts

1. Attach right rear mount (1) to the tractor clutch housing using two cap screws (12) and hardened flat washers (14) in the top holes and two cap screws (16) hardened flat washers (14) in the lower two holes.
2. Repeat to install left rear mount (2).

1. 1026490 Right rear mount
2. 1026491 Left rear mount
12. 300517 3/4 NC x 1-3/4 HHCS GR5
14. 57798 3/4 Hardened flat washer
16. 735 3/4 NC x 2 HHCS GR5

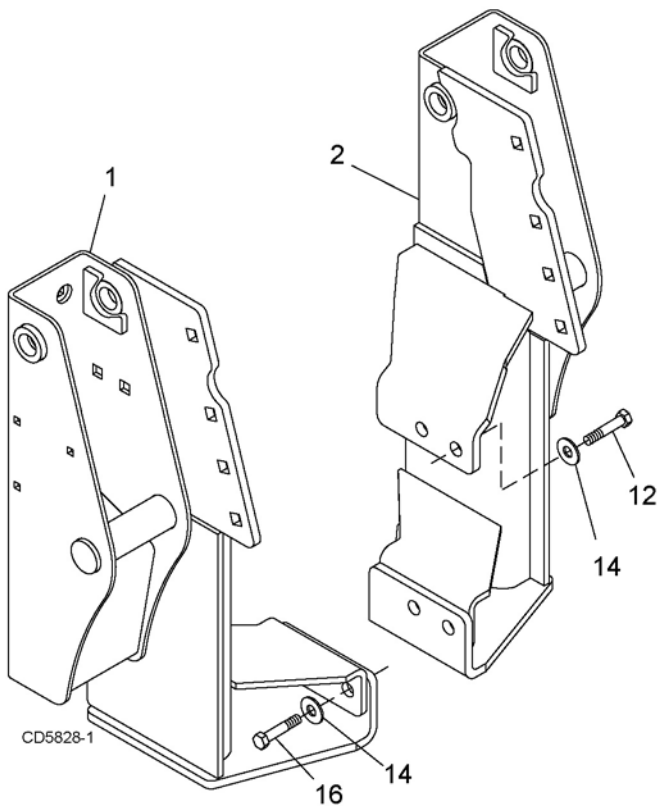

Figure 1. Rear Mount Installation

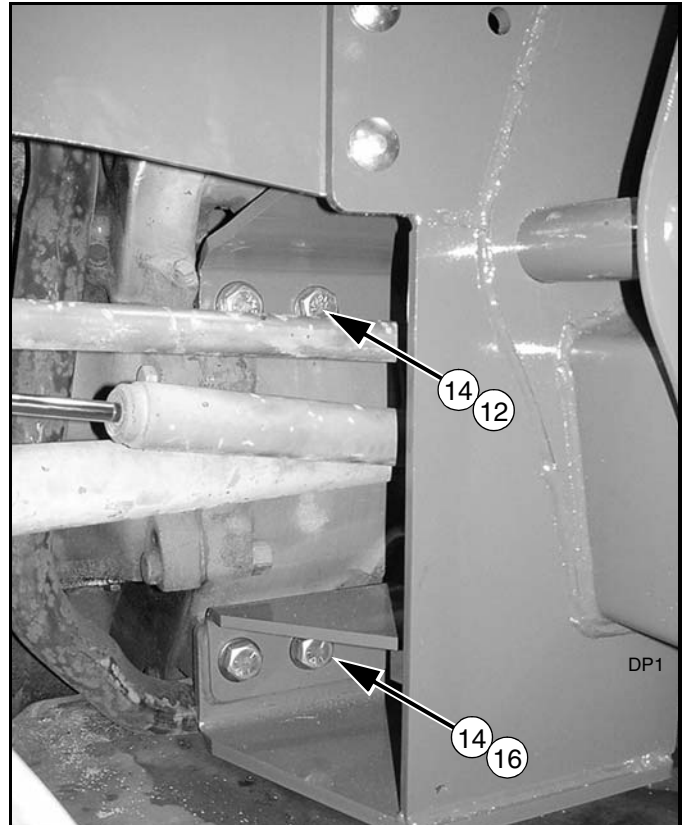

Figure 2. Left rear Mount Installed

Install Front Mount

1. Insert four (two per side) carriage bolts (13) into upper holes of front mount prior to attaching to tractor. Carriage bolts should be inserted from the inside pointing outward.
2. Attach front support (3) to tractor, using two cap screws (17) and hardened flat washers (15).

- 3. 1001642 Front mount
- 13. 301130 5/8 NC x 1-1/2 Carriage bolt GR5
- 15. 57817 5/8 Hardened flat washer
- 17. 902 5/8 NC x 2 HHCS GR5

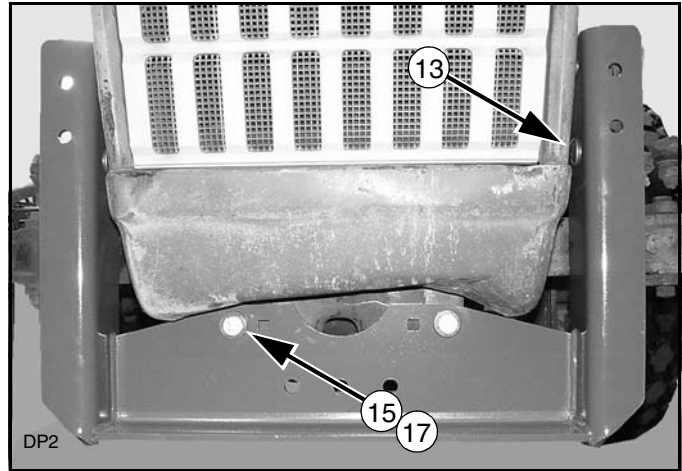

Figure 3. Front Mount Installed

Install Right and Left Side rails

1. Place front holes of right side rail (4) over carriage bolts (13) and front mount and secure with hardened flat washers (15) and hex nuts (10).
2. Attach side rail to inside of rear mount, using four carriage bolts (13), hardened flat washers (15) and hex nuts (10).

Carriage bolts must be installed with heads on inside of rear mount as shown in Figure 6.

3. Repeat steps to install left side rail (5).

- 4. 1026492 Right side rail
- 5. 1026493 Left side rail
- 10. 230 5/8 NC Hex nut
- 13. 301130 5/8 NC x 1-1/2 Carriage bolt GR5
- 15. 57817 5/8 Hardened flat washer

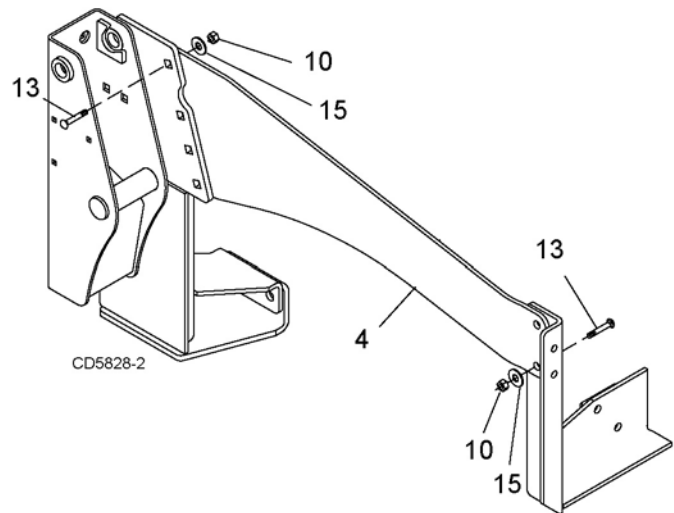

Figure 4. Right Side Rail Installation

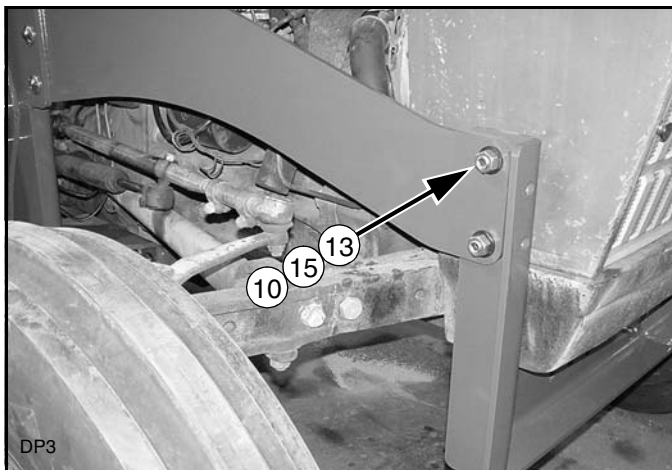

Figure 5. Side Rail to Front Mount

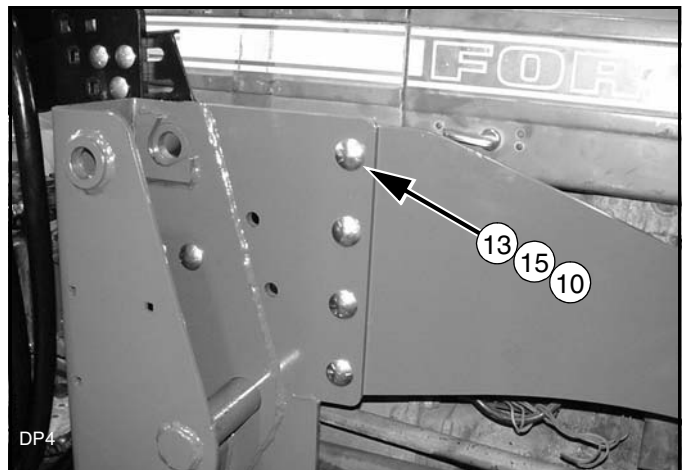

Figure 6. Side Rail to Rear Mount

6 Mount Installation

Install Grill Guard (Optional)

Attach grill guard (21) to front mount (3) using four (two per side) cap screw (23), lock washers (25), hardened flat washers (24) and hex nuts (22).

Torque hardware to:85 lbs-ft (115 N-m)

- 3. 1001642 Front mount
- 21. 57822 Grill guard
- 22. 1093 1/2 NC Hex nut
- 23. 3379 1/2 NC x 1-1/2 HHCS GR5
- 24. 57816 1/2 Hardened flat washer
- 25. 855 1/2 Lock washer

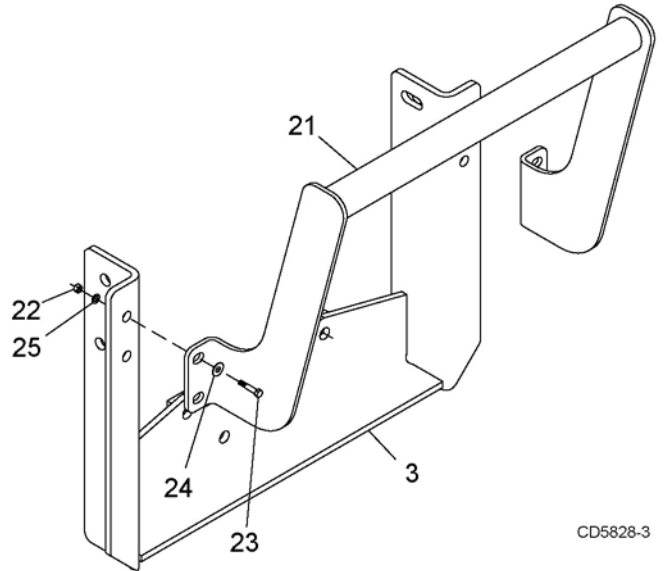

CD5828-3

Figure 7. Grill Guard Installation

Torque Hardware

Torque all hardware to specifications listed below.

TORQUE SPECIFICATIONS				
Ref	Cap Screw	Qty	Wrench Size	Required Torque
12	3/4 NC x 1-3/4	4	1-1/8"	297 lbs.-ft. (403 N-m)
13	5/8 NC x 1-1/2 (Carriage Bolt)	12	15/16"	170 lbs.-ft. (230 N-m)
16	3/4 NC x 2	4	1-1/8"	297 lbs.-ft. (403 N-m)
17	5/8 NC x 1-1/2	2	15/16"	170 lbs.-ft. (230 N-m)

NOTES

HOSE KIT INSTALLATION

WARNING

■ Keep hands and body away from pressurized lines. Use paper or cardboard, not hands or other body parts to check for leaks. Wear safety goggles. Hydraulic fluid under pressure can easily penetrate skin and will cause serious injury or death.

■ Make sure that all operating and service personnel know that if hydraulic fluid penetrates skin, it must be surgically removed as soon as possible by a doctor familiar with this form of injury or gangrene, serious injury, or death will result. **CONTACT A PHYSICIAN IMMEDIATELY IF FLUID ENTERS SKIN OR EYES. DO NOT DELAY.**

■ Air in hydraulic systems can cause erratic operation and allows loads or equipment components to drop unexpectedly. When connecting equipment or hoses or performing any hydraulic maintenance, purge any air in hydraulic system by operating all hydraulic functions several times. Do this before putting into service or allowing anyone to approach the equipment.

WARNING

■ Protective hose sleeves must cover all hydraulic hoses within 20 inches of the operator and be secured onto metal hose fittings. Replace hoses or sleeves if damaged or if protective sleeve cannot be properly positioned or secured.

■ Make sure all hydraulic hoses, fittings, and valves are in good condition and not leaking before starting power unit or using equipment. Check and route hoses carefully to prevent damage. Hoses must not be twisted, bent sharply, kinked, frayed, pinched, or come into contact with any moving parts. Operate moveable components through full operational range to check clearances. Replace any damaged hoses immediately.

57923 Hose Kit Installation	-----	page 9
1001420 Hose Kit Installation	-----	page 12
1023582 Hose Kit Installation	-----	page 16
1023596 Hose Kit Installation	-----	page 19

57923 HOSE KIT

General Description

These instructions are for operating the 1020/1027 loader using the tractor hydraulic remote control lever. To use this hydraulic connection, the tractor must be equipped with two hydraulic levers and four tractor hydraulic couplers.

NOTE: Male quick couplers (3) for connection to tractor are NOT included with the hose kit but are available as service parts.

Install Hose Fittings

1. Attach elbow (2) and male quick coupler (3) to each loader supply hose (1).
2. Connect loader supply hoses to loader steel feedlines following pattern shown in Figure 8.
 1. 57912 Hose, 120" x 1/2 JICM x JICM
 2. 313053 Elbow, 3/4 JICF x 1/2 NPTM
 3. 66511 Quick coupler, male 1/2

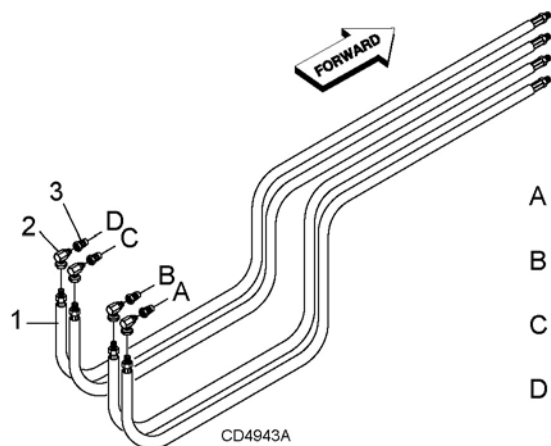

- A - BUCKET CYL. BASE END (DUMP) - RED
- B - BUCKET CYL. ROD END (ROLLBACK) - BLUE
- C - BOOM CYL. ROD END (DOWN) - YELLOW
- D - BOOM CYL. BASE END (UP) - GREEN

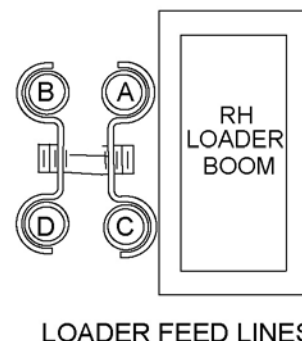

Figure 8. 1020/1027 Loader Supply Hose Connection

59723 Hose Kit

Route Hydraulic Hoses

Route hoses along loader mount, under the right side of the operator's platform, and over the rear axle.

Be sure to avoid contact with 3-point linkage, brake pedals, and other moveable tractor components.

Hoses must be routed so they are not pinched, bent sharply, or chafed during operation. Hoses must not interfere with any tractor control operation or contact any moving parts.

Connect hydraulic hoses to tractor hydraulic couplers as shown in Figure 9 when loader is attached to tractor.

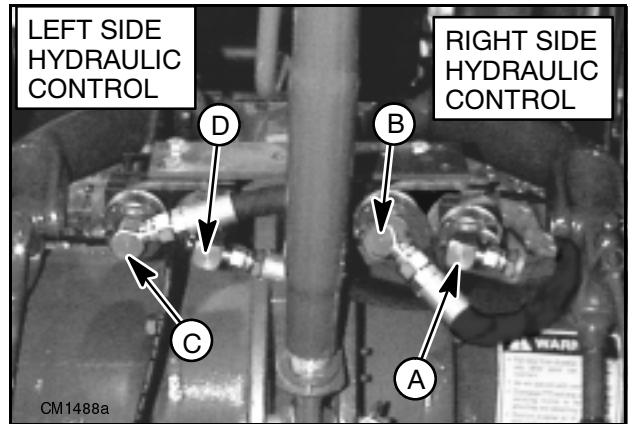

Figure 9. Hydraulic Hose Connection to Tractor

Install Hose Hanger

1. Install hose hanger bracket beneath right side of the operator's platform as shown in Figure 10. Use cap screw, flat washers, and lock nut as shown in Figure 11.
2. Route hoses through support and secure with lock pin (15).

11. 58033 Hose hanger bracket
12. 6778 5/16 NC Lock nut
13. 4378 5/16 Flat washer
14. 6250 5/16 NC x 1-1/4 HHCS
15. 58047 1/4 x 2-1/2 Lock pin

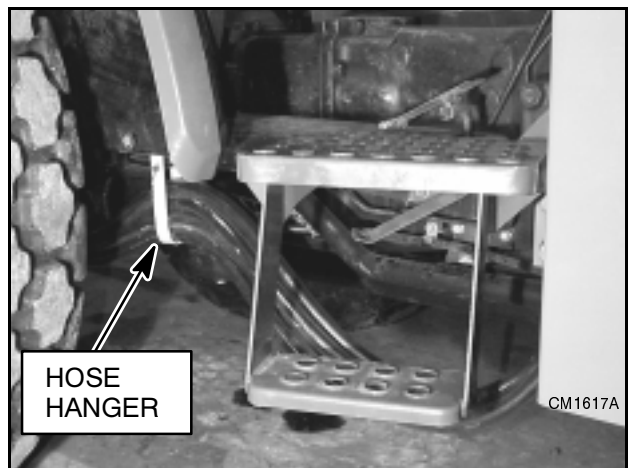

Figure 10. Hose Hanger Installed

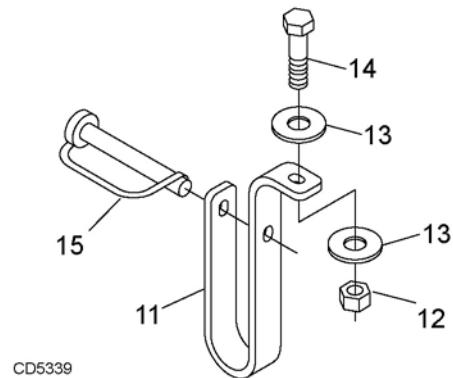
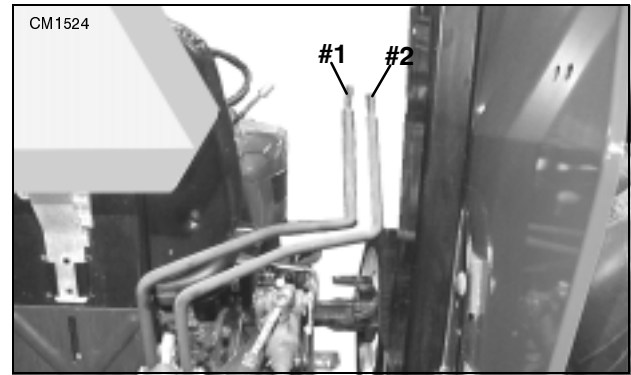

Figure 11. Hose Hanger Assembly

Verify Control Movements

- 1. Mount loader to tractor:** Remove mount pins from loader uprights. Align tractor with loader and slowly drive tractor into loader. Shut off tractor.
- 2.** Connect loader feedline hoses to the loader control valve quick couplers. See Figure 19.
- 3.** Comply with all safety rules and start the tractor.
- 4.** Mount loader to tractor by activating bucket cylinders to raise or lower the loader uprights into the loader mounts. Slowly drive tractor forward, activating appropriate cylinders to engage loader completely into mounts. Insert mounting pins to secure loader.
- 5.** Check that all tractor hydraulic control lever positions operate the loader movements correctly. See Figure 20.
- 6.** If loader movements do not respond correctly, shut off tractor, relieve pressure, and reconnect properly. Loader control movements must be correct before proceeding.
- 7.** Once all loader functions are correct, start the tractor and operate the loader to check for leaks. Purge any remaining air from the hydraulic system and check oil level.
- 8.** When hose routings and correct loader operations are verified, identify each circuit by placing a matching colored band around the male and female quick-disconnect coupler. The color-coded bands will make reinstallation easier once the loader has been removed from the tractor.
- 9.** Attach the plastic tie straps (included in kit) every 20 inches around the hoses to keep them tightly bundled and away from contact with the ground or other moving parts on the tractor or loader.
- 10.** Before operating the loader, make sure that the Pre-Delivery, Delivery, and Pre-Operation Check Lists from the Loader Operator's Manual have been completed.



- Control Handle 1 Forward - Boom down
- Control Handle 1 Back - Boom up
- Control Handle 2 Forward - Dump bucket or attachment
- Control Handle 2 Back - Roll back bucket or attachment

Figure 12. Tractor Control Lever Operation

1001420 HOSE KIT

General Description

These set-up instructions are for operating the 1020/1027 loader using a single-lever control mounted on the right loader upright as shown Figure 13. To use this hydraulic connection, hose kit 1001420 must be connected between loader control valve and tractor hydraulics.

Install control valve before proceeding.

NOTICE

■ If hydraulic lines are not connected as shown in this manual, the control valve may be damaged. A blocked outlet (RETURN) or improper hose connection will cause pressurized oil to enter the return circuit and damage the valve.

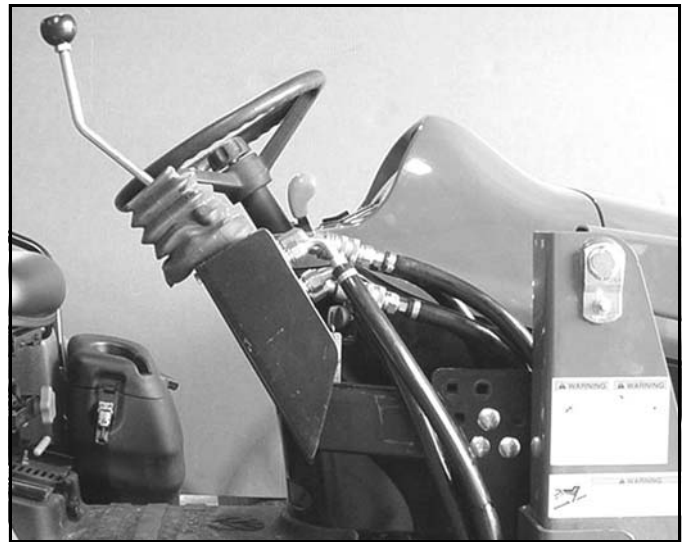

Figure 13. 2-Spool Control Valve Installed (Typical)

Install Adapter Plate

NOTICE

■ Removal of the accessory plate or remote valves with a load being held on the 3-point hitch will result in escape of high pressure oil and sudden, uncontrolled drop of 3-point hitch arms.

Before attempting to install this kit, the following must be observed:

- Shut off engine, place transmission in neutral, and apply parking brake.
- Fully lower any equipment supported by the tractor remote hydraulic valves, if so equipped. Activate any remote valves to relieve all hydraulic pressure in the remote circuits.
- Fully lower the 3-point hitch.

1. Thoroughly clean the top front of the hydraulic accessory plate.
2. Install elbows (1) and (2) to adapter plate (3).
3. Remove accessory plate cover (A). Be careful not to disturb the O-rings that need to stay with the cover plate when it is removed.
4. Install O-rings to bottom of adapter plate (3). Use petroleum jelly to keep the O-rings in the counterbores.
5. Place the adapter plate over hydraulic opening.
6. Place the accessory plate cover onto the adapter plate. Make sure O-rings stay in the counterbores.

7. Secure with hex head cap screws and flat washer as shown in Figure 14.
8. Secure elbows (1) and (2) as shown.

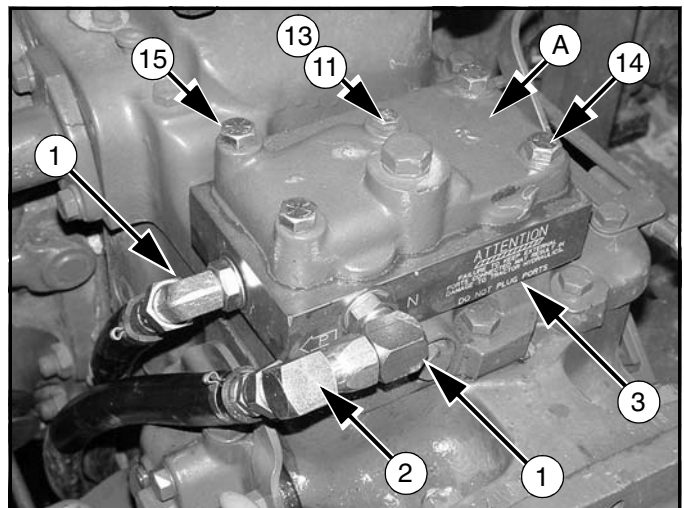

Figure 14. Adapter Plate Installed

- | | | |
|-----|---------|--------------------------------|
| A. | ----- | Accessory plate cover |
| 1. | 316004 | Elbow, 3/4 JICM x 3/4 ORBM 90° |
| 2. | 313032 | Elbow, 3/4 JICM x 3/4 JICF 90° |
| 3. | 1001421 | Adapter plate |
| 11. | 4378 | 5/16 Standard flat washer |
| 13. | 21548 | 5/16 NC x 3-1/4 HHCS |
| 14. | 21549 | 7/16 NC x 3 HHCS |
| 15. | 1001423 | 7/16 NC x 4-3/4 HHCS |

1001420 Hose Kit

Install Hoses

1. Attach 90° end of hoses (7) to the IN, OUT and PBY ports of the loader control valve.
2. Locate the fill plug on the top of right rear axle and remove.
3. Install adapter (5) and elbow (6) into opening.
4. Attach hose from the PBY port on the loader control valve to elbow (2) in the PBY (N) port on the front of adapter plate (3).
5. Attach hose from the IN port on the loader control valve to elbow (1) in the PRESSURE (P) port on the side of adapter plate.
6. Attach hose from the OUT port on the loader control valve to elbow (6) in the RETURN port on the top of the rear axle.

1. 316004 Elbow, 3/4 JICM x 3/4 ORBM 90°
2. 313032 Elbow, 3/4 JICM x 3/4 JICF 90°
5. 1001419 Adapter, 7/8 O-ring F x 1-3/8 Trd M
or
5. 1001657 Adapter, 7/8 O-ring F x 1-5/8 Trd M
6. 60 Elbow, 3/4 JICM x 7/8 ORBM 90°
7. 1001422 Hose, 86" x 3/4 JICF x 3/4 JICF

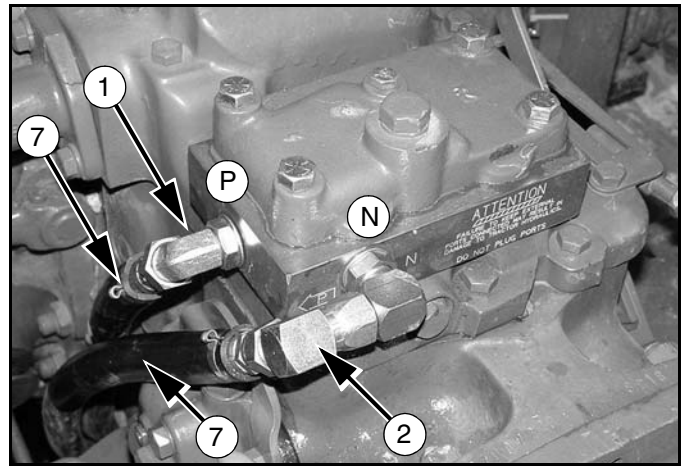

Figure 15. Hose Connection at Adapter Plate

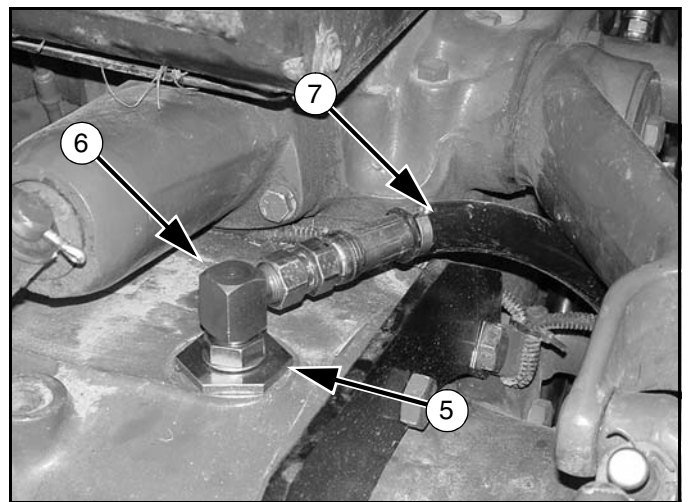

Figure 16. RETURN Port Connection

1001420 Hose Kit

Install Hose Hanger

1. Install hose hanger bracket (8) under platform between brake pedals and chassis as shown in Figure 17.
2. Secure with hex head cap screw (10), flat washers (11), and lock nut (12).
3. Route hoses through hose hanger bracket and up behind right platform as shown in Figure 18.
4. Secure hoses in hose hanger with lock pin (9).
5. Secure hoses every 20 inches with plastic ties.

- 8. 58033 Hose hanger bracket
- 9. 58047 1/4 x 2-1/2 Lock pin
- 10. 6250 5/16 NC x 1-1/4 HHCS
- 11. 4378 5/16 Standard flat washer
- 12. 6778 5/16 NC Lock nut

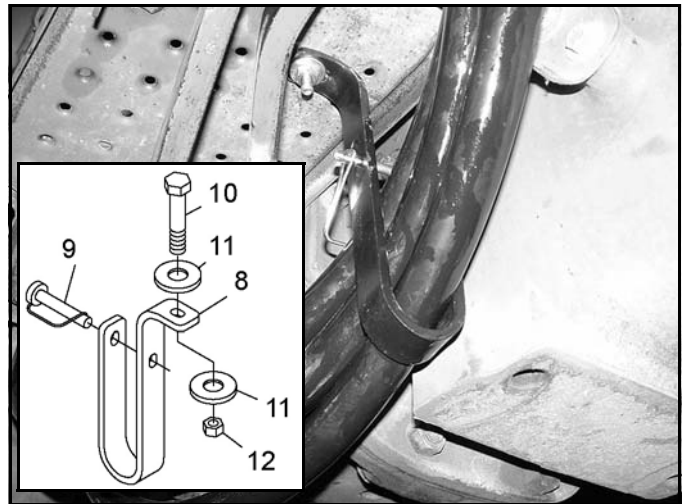

Figure 17. Hose Hanger Installed

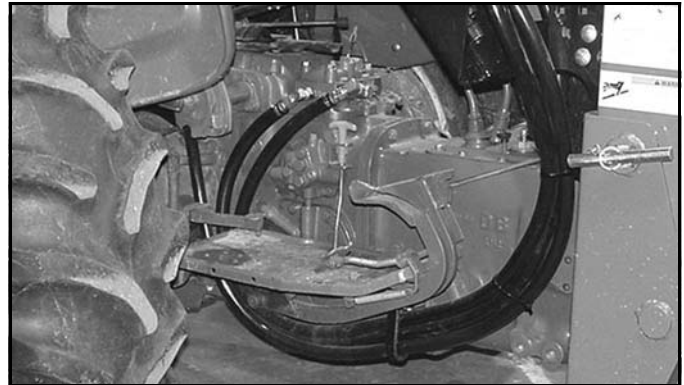
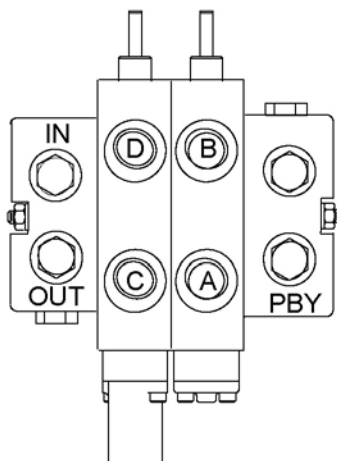

Figure 18. Hose Routing

Connect Loader Feedline Hoses

1. The control valve kit contains hoses assembled with quick couplers. Attach the hoses to loader feedlines, following the color pattern.
2. Connect loader supply hoses to control valve hydraulic couplers when attaching loader.



2 - Spool Control Valve

- A - BUCKET CYL. BASE END (DUMP) - RED
- B - BUCKET CYL. ROD END (ROLLBACK) - BLUE
- C - BOOM CYL. ROD END (DOWN) - YELLOW
- D - BOOM CYL. BASE END (UP) - GREEN

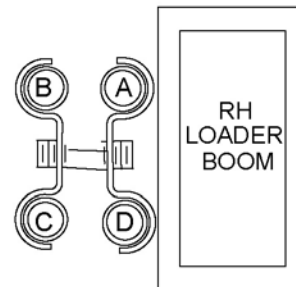

LOADER FEEDLINES

Figure 19. Control Valve and 1020/1027 Loader Feedline Connections

14 Hydraulic Installation

Verify Control Movements

- 1. Mount loader to tractor:** Remove mount pins from loader uprights. Align tractor with loader and slowly drive tractor into loader. Shut off tractor.
- 2.** Connect loader feedline hoses to the loader control valve quick couplers. See Figure 19.
- 3.** Comply with all safety rules and start the tractor.
- 4.** Mount loader to tractor by activating bucket cylinders to raise or lower the loader uprights into the loader mounts. Slowly drive tractor forward, activating appropriate cylinders to engage loader completely into mounts. Insert mounting pins to secure loader.
- 5.** Check that all tractor hydraulic control lever positions operate the loader movements correctly. See Figure 20.
- 6.** If loader movements do not respond correctly, shut off tractor, relieve pressure, and reconnect properly. Loader control movements must be correct before proceeding.
- 7.** Once all loader functions are correct, start the tractor and operate the loader to check for leaks. Purge any remaining air from the hydraulic system and check oil level.
- 8.** When hose routings and correct loader operations are verified, identify each circuit by placing a matching colored band around the male and female quick-disconnect coupler. The color-coded bands will make reinstallation easier once the loader has been removed from the tractor.
- 9.** Attach the plastic tie straps (included in kit) every 20 inches around the hoses to keep them tightly bundled and away from contact with the ground or other moving parts on the tractor or loader.
- 10.** Before operating the loader, make sure that the Pre-Delivery, Delivery, and Pre-Operation Check Lists from the Loader Operator's Manual have been completed.

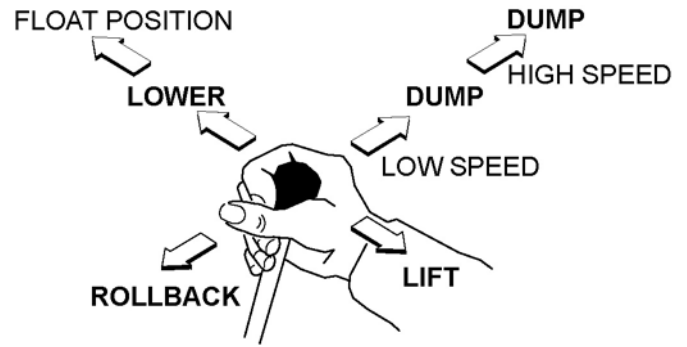

- Handle forward - Boom down
- Handle forward to limit - Float position
- Handle back - Boom up
- Handle right -
Dump bucket or attachment (slow)
- Handle right to limit -
Dump bucket or attachment (fast)
- Handle to left - Rollback bucket or attachment

Figure 20. Single Lever Control Operation

1023582 HOSE KIT

General Description

These set up instructions are for operating the LU126 loader using a single lever control valve mounted to the right loader mount bracket as shown in Figure 21. To use this hydraulic connection, hose kit 1023582 must be connected between loader control valve and tractor hydraulics.

Install loader control valve before proceeding.

NOTICE

■ If hydraulic lines are not connected as shown in this manual, the control valve may be damaged. A blocked outlet (RETURN) or improper hose connection will cause pressurized oil to enter the return circuit and damage the valve.

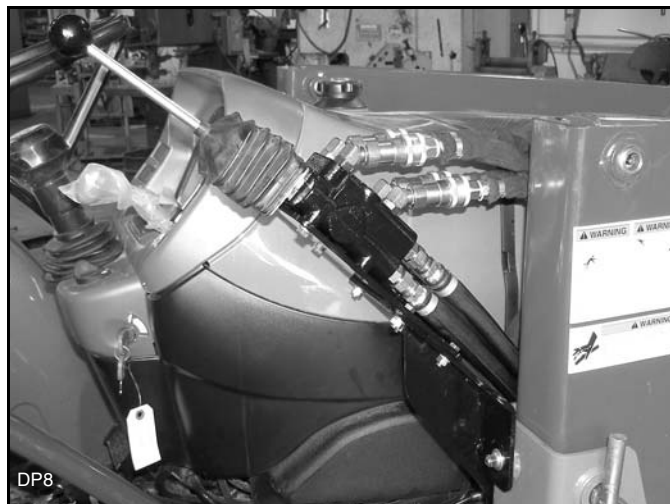

Figure 21. Control Valve Installed

Install Adapter Plate

NOTICE

■ Removal of the accessory plate or remote valves with a load being held on the 3-point hitch will result in escape of high pressure oil and sudden, uncontrolled drop of 3-point hitch arms.

Before attempting to install this kit, the following must be observed:

- Shut off engine, place transmission in neutral, and apply parking brake.
- Fully lower any equipment supported by the tractor remote hydraulic valves, if so equipped. Activate any remote valves to relieve all hydraulic pressure in the remote circuits.
- Fully lower the 3-point hitch.

1. Thoroughly clean the top front of the hydraulic accessory plate.
2. Install elbow (12) and adapter (21) to adapter plate (2).
3. Remove accessory plate cover (A). Be careful not to disturb the O-rings that need to stay with the cover plate when it is removed.
4. Install O-rings to bottom of adapter plate (2). Use petroleum jelly to keep the O-rings in the counterbores.
5. Place the adapter plate over hydraulic opening.

6. Place the accessory plate cover onto the adapter plate. Make sure O-rings stay in the counterbores.
7. Secure with hex head cap screws and flat washer as shown in Figure 22.

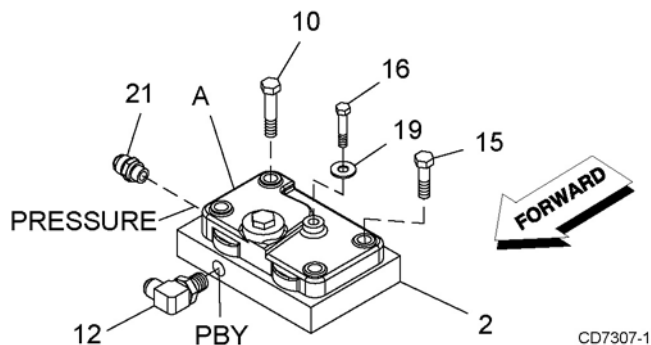

Figure 22. Adapter Plate Installed

- | | | |
|-----|---------|--------------------------------|
| A. | ----- | Accessory plate cover |
| 2. | 1001421 | Adapter plate |
| 10. | 1001423 | 7/16 NC X 4-3/4 HHCS |
| 12. | 316004 | Elbow, 3/4 JICM x 3/4 ORBM 90° |
| 15. | 21549 | 7/16 NC X 3 HHCS |
| 16. | 21548 | 5/16 NC x 3-1/4 HHCS |
| 19. | 4378 | 5/16 Standard flat washer |
| 21. | 61 | Adapter, 3/4 JICM x 3/4 ORBM |

1023582 Hose Kit

Install Hoses

1. Attach straight end of hoses (1) to the IN, OUT and PBY ports of the loader control valve.
2. Locate the fill plug on the top of right rear axle and remove.
3. Install adapter (3) and adapter (11) into opening.
4. Attach hose from the PBY port on the loader control valve to elbow (12) in the PBY (N) port on the front of adapter plate (2).
5. Attach hose from the IN port on the loader control valve to adapter (21) in the PRESSURE (P) port on the side of adapter plate.
6. Attach hose from the OUT port on the loader control valve to adapter (11) in the RETURN port on the top of the rear axle.

1. 1001422 Hose, 86" x 3/4 JICF x 3/4 JICF
2. 1001421 Adapter plate
3. 1001419 Adapter, 7/8 O-ring F x 1-3/8 Trd M
3. 1001657 Adapter, 7/8 O-ring F x 1-5/8 Trd M
11. 316016 Adapter, 3/4 JICM x 7/8 ORBM
12. 316004 Elbow, 3/4 JICM x 3/4 ORBM 90°
21. 61 Adapter, 3/4 JICM x 7/8 ORBM 90°

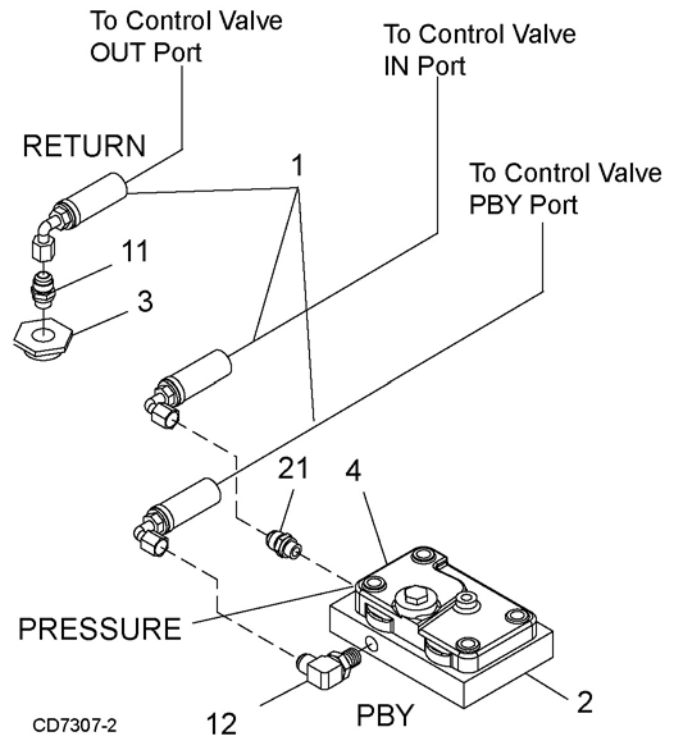

Figure 23. Hydraulic Fitting Installation

Install Hose Hanger

1. Install hose hanger bracket (14) under platform between brake pedals and chassis as shown in Figure 24.
2. Secure with hex head cap screw (18), flat washers (19), and lock nut (17).
3. Route hoses through hose hanger bracket and up behind right platform as shown in Figure 18.
4. Secure hoses in hose hanger with lock pin (13).
5. Secure hoses every 20 inches with plastic ties.

14. 58033 Hose hanger bracket
13. 58047 1/4 x 2-1/2 Lock pin
17. 6778 5/16 NC Lock nut
18. 6250 5/16 NC x 1-1/4 HHCS
19. 4378 5/16 Standard flat washer

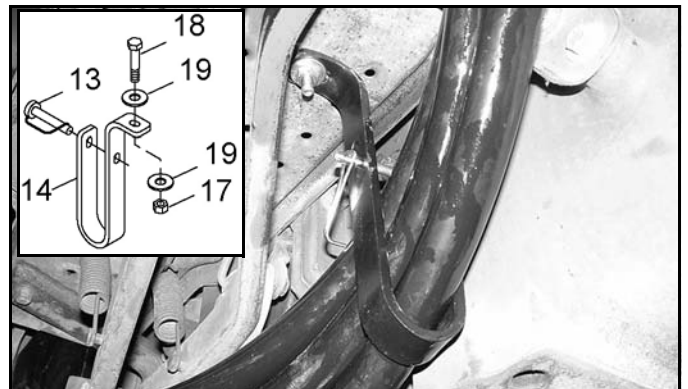

Figure 24. Hose Hanger Installed

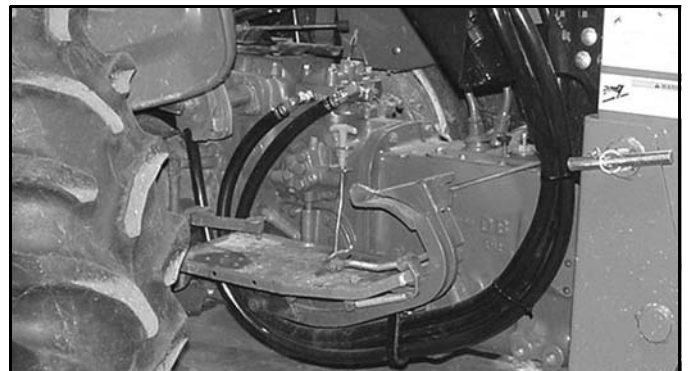
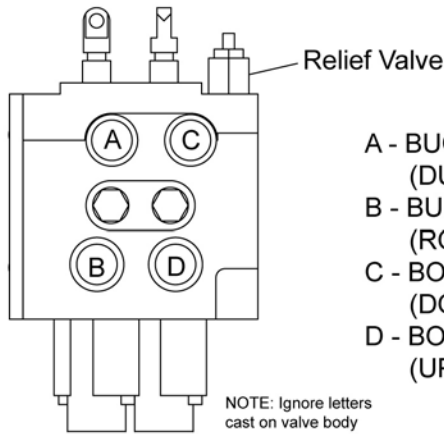

Figure 25. Hose Routing

Connect Loader Feedline Hoses

1. The control valve kit contains hoses assembled with quick couplers. Attach the hoses to loader feedlines, following the color pattern.

2. Connect loader supply hoses to control valve hydraulic couplers when attaching loader.



- A - BUCKET CYL. BASE END (DUMP) - RED
- B - BUCKET CYL. ROD END (ROLLBACK) - BLUE
- C - BOOM CYL. ROD END (DOWN) - YELLOW
- D - BOOM CYL. BASE END (UP) - GREEN

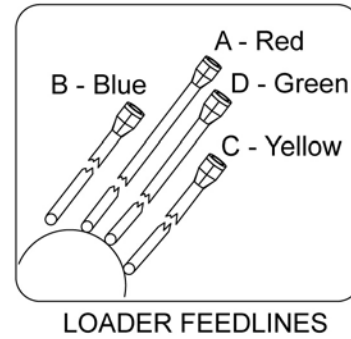
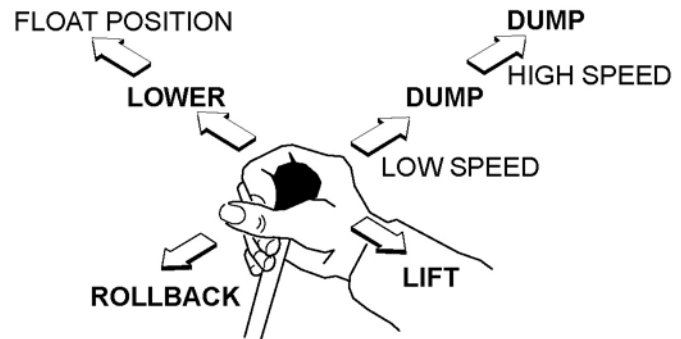

Figure 26. Control Valve & LU126 Loader Feedline Connections

Verify Control Movements

1. **Mount loader to tractor:** Remove mount pins from loader uprights. Align tractor with loader and slowly drive tractor into loader. Shut off tractor.
2. Connect loader feedline hoses to the loader control valve quick couplers. See Figure 26.
3. Comply with all safety rules and start the tractor.
4. Mount loader to tractor by activating bucket cylinders to raise or lower the loader uprights into the loader mounts. Slowly drive tractor forward, activating appropriate cylinders to engage loader completely into mounts. Insert mounting pins to secure loader.
5. Check that all tractor hydraulic control lever positions operate the loader movements correctly. See Figure 27.
6. If loader movements do not respond correctly, shut off tractor, relieve pressure, and reconnect properly. Loader control movements must be correct before proceeding.
7. Once all loader functions are correct, start the tractor and operate the loader to check for leaks. Purge any remaining air from the hydraulic system and check oil level.
8. When hose routings and correct loader operations are verified, identify each circuit by placing a matching colored band around the male and female quick-disconnect coupler. The color-coded bands will make reinstallation easier once the loader has been removed.

9. Attach the plastic tie straps (included in kit) every 20 inches around the hoses to keep them tightly bundled and away from contact with the ground or other moving parts on the tractor or loader.
10. Before operating the loader, make sure that the Pre-Delivery, Delivery, and Pre-Operation Check Lists from the Loader Operator's Manual have been completed.



- Handle forward - Boom down
- Handle forward to limit - Float position
- Handle back - Boom up
- Handle right - Dump bucket or attachment (slow)
- Handle right to limit - Dump bucket or attachment (fast)
- Handle to left - Rollback bucket or attachment

Figure 27. Single Lever Control Operation

1023596 HOSE KIT

General Description

These instructions are for operating the LU126 loader using the tractor hydraulic remote control lever. To use this hydraulic connection, the tractor must be equipped with four tractor hydraulic couplers.

NOTE: Male quick couplers (3) for connection to tractor are NOT included with the hose kit but are available as service parts.

Install Hose Fittings

1. Attach elbow (2) and male quick coupler (3) to each loader supply hose (1).
2. Connect loader supply hoses to loader steel feedlines. Following pattern shown in Figure 8.
 1. 1023472 Hose, 170" x 3/4 JICM x 3/4 JICM
 2. 313053 Elbow, 3/4 JICF x 1/2 NPTM
 3. 66511 Quick coupler, male 1/2

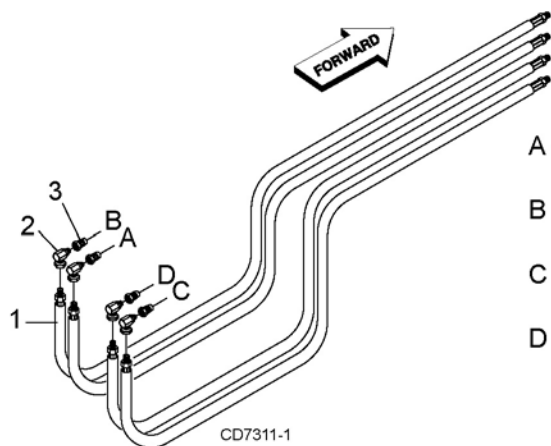

A - BUCKET CYL. BASE END (DUMP) - RED
B - BUCKET CYL. ROD END (ROLLBACK) - BLUE
C - BOOM CYL. ROD END (DOWN) - YELLOW
D - BOOM CYL. BASE END (UP) - GREEN

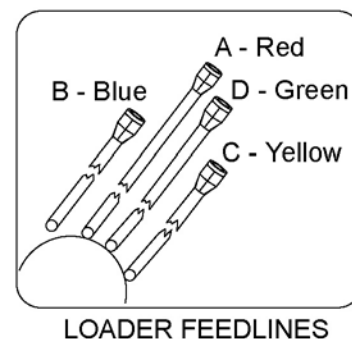

Figure 28. LU126 Loader Supply Hose Connection

Route Hydraulic Hoses

Route hoses along loader mount, under the right side of the operator's platform, and over the rear axle.

Be sure to avoid contact with 3-point linkage, brake pedals, and other moveable tractor components.

Hoses must be routed so they are not pinched, bent sharply, or chafed during operation. Hoses must not interfere with any tractor control operation or contact any moving parts.

Connect hydraulic hoses to tractor hydraulic couplers.

Install Hose Hanger

1. Install hose hanger bracket beneath right side of the operator's platform as shown in Figure 29. Use cap screw, flat washers, and lock nut as shown in Figure 29.
2. Route hoses through support and secure with lock pin (12).

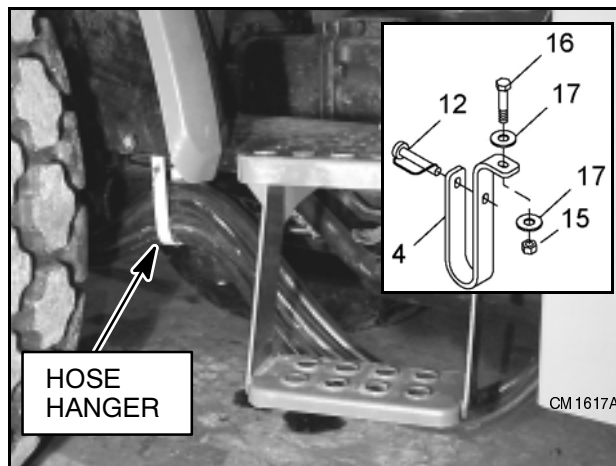
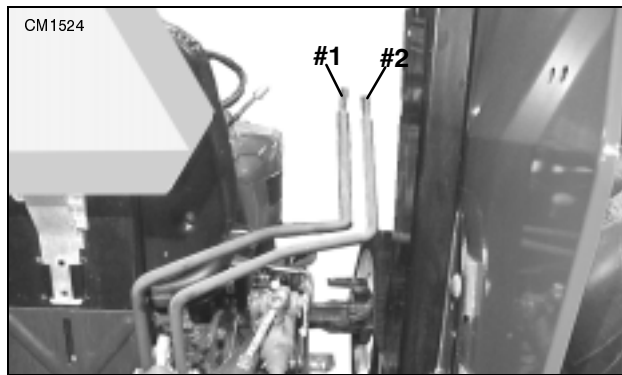

Figure 29. Hose Hanger Installed

4. 58033 Hose hanger bracket
12. 58047 1/4 x 2-1/2 Lock pin
15. 6778 5/16 NC Lock nut
16. 6250 5/16 NC x 1-1/4 HHCS
17. 4378 5/16 Standard flat washer

Verify Control Movements

- 1. Mount loader to tractor:** Remove mount pins from loader uprights. Align tractor with loader and slowly drive tractor into loader. Shut off tractor.
2. Connect loader feedline hoses to the loader control valve quick couplers. See Figure 19.
3. Comply with all safety rules and start the tractor.
4. Mount loader to tractor by activating bucket cylinders to raise or lower the loader uprights into the loader mounts. Slowly drive tractor forward, activating appropriate cylinders to engage loader completely into mounts. Insert mounting pins to secure loader.
5. Check that all tractor hydraulic control lever positions operate the loader movements correctly. See Figure 20.
6. If loader movements do not respond correctly, shut off tractor, relieve pressure, and reconnect properly. Loader control movements must be correct before proceeding.
7. Once all loader functions are correct, start the tractor and operate the loader to check for leaks. Purge any remaining air from the hydraulic system and check oil level.
8. When hose routings and correct loader operations are verified, identify each circuit by placing a matching colored band around the male and female quick-disconnect coupler. The color-coded bands will make reinstallation easier once the loader has been removed from the tractor.
9. Attach the plastic tie straps (included in kit) every 20 inches around the hoses to keep them tightly bundled and away from contact with the ground or other moving parts on the tractor or loader.
10. Before operating the loader, make sure that the Pre-Delivery, Delivery, and Pre-Operation Check Lists from the Loader Operator's Manual have been completed.



- Control Handle 1 Forward - Boom down
- Control Handle 1 Back - Boom up
- Control Handle 2 Forward - Dump bucket or attachment
- Control Handle 2 Back - Roll back bucket or attachment

Figure 30. Tractor Control Lever Operation

111877 LOADER MOUNTING KIT

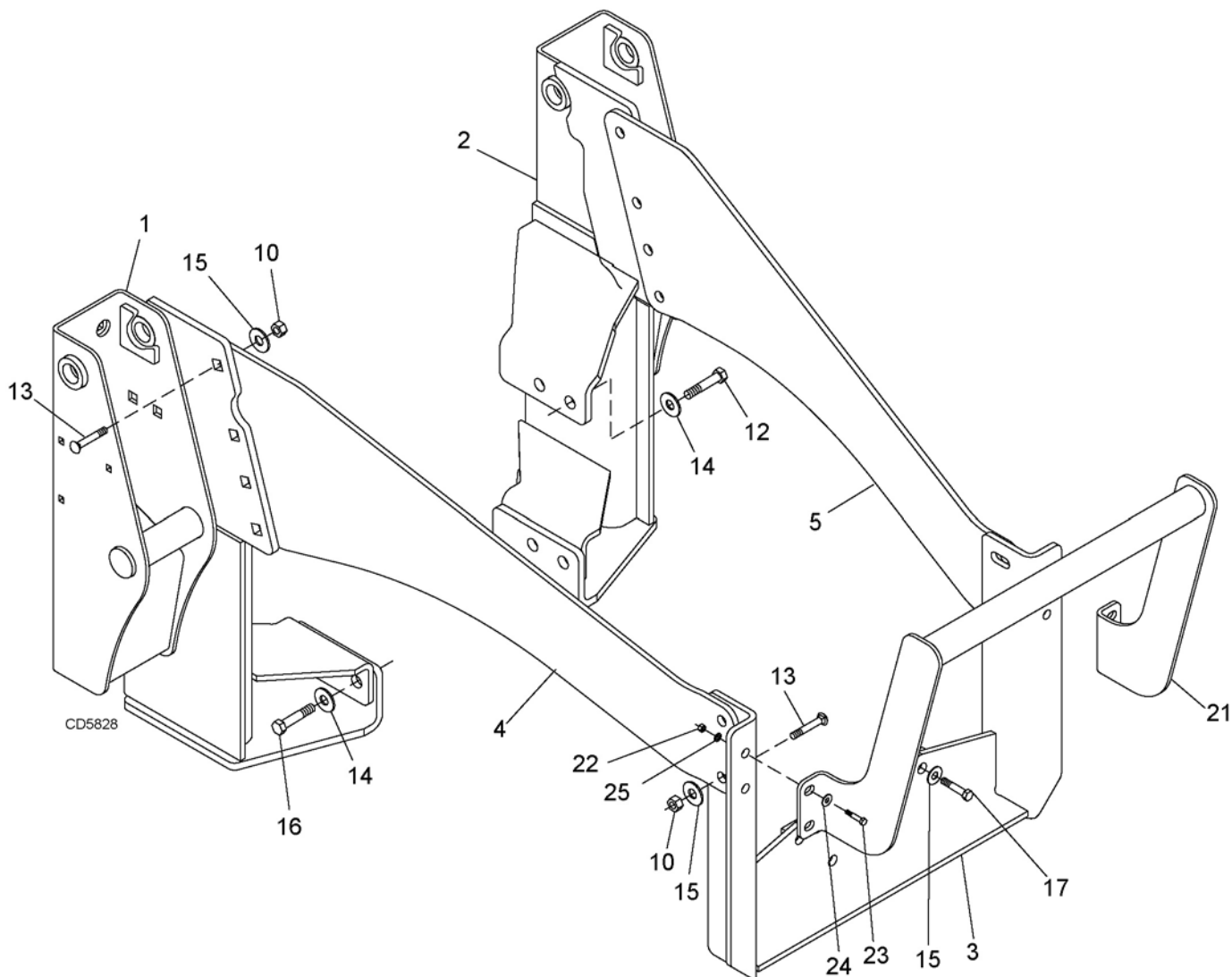

REF	PART	QTY	DESCRIPTION
1	1026490	1	Right rear mount
2	1026491	1	Left rear mount
3	1001642	1	Front mount
4	1026492	1	Right side rail
5	1026493	1	Left side rail
10	230 *	12	5/8 NC Plated Hex nut
12	300517 *	4	3/4 NC x 1-3/4 HHCS GR5
13	301130 *	12	5/8 NC x 1-1/2 Carriage bolt GR5
14	57798	8	3/4 Hardened flat washer

REF	PART	QTY	DESCRIPTION
15	57817	14	5/8 Hardened flat washer
16	735 *	8	3/4 NC x 2 HHCS
17	902 *	2	5/8 NC x 2 HHCS
20	57913	1	Grill guard kit - optional (includes items 21 through 25)
21	57822	1	Grill guard
22	1093 *	4	1/2 NC Plated hex nut
23	3379 *	4	1/2 NC x 1-1/2 HHCS GR5
24	57816	4	1/2 Hardened flat washer
25	855 *	4	1/2 Lock washer

HHCS Hex Head Cap Screw

* Standard hardware, obtain locally

1001420 HOSE KIT

(1020/1027 LOADERS)

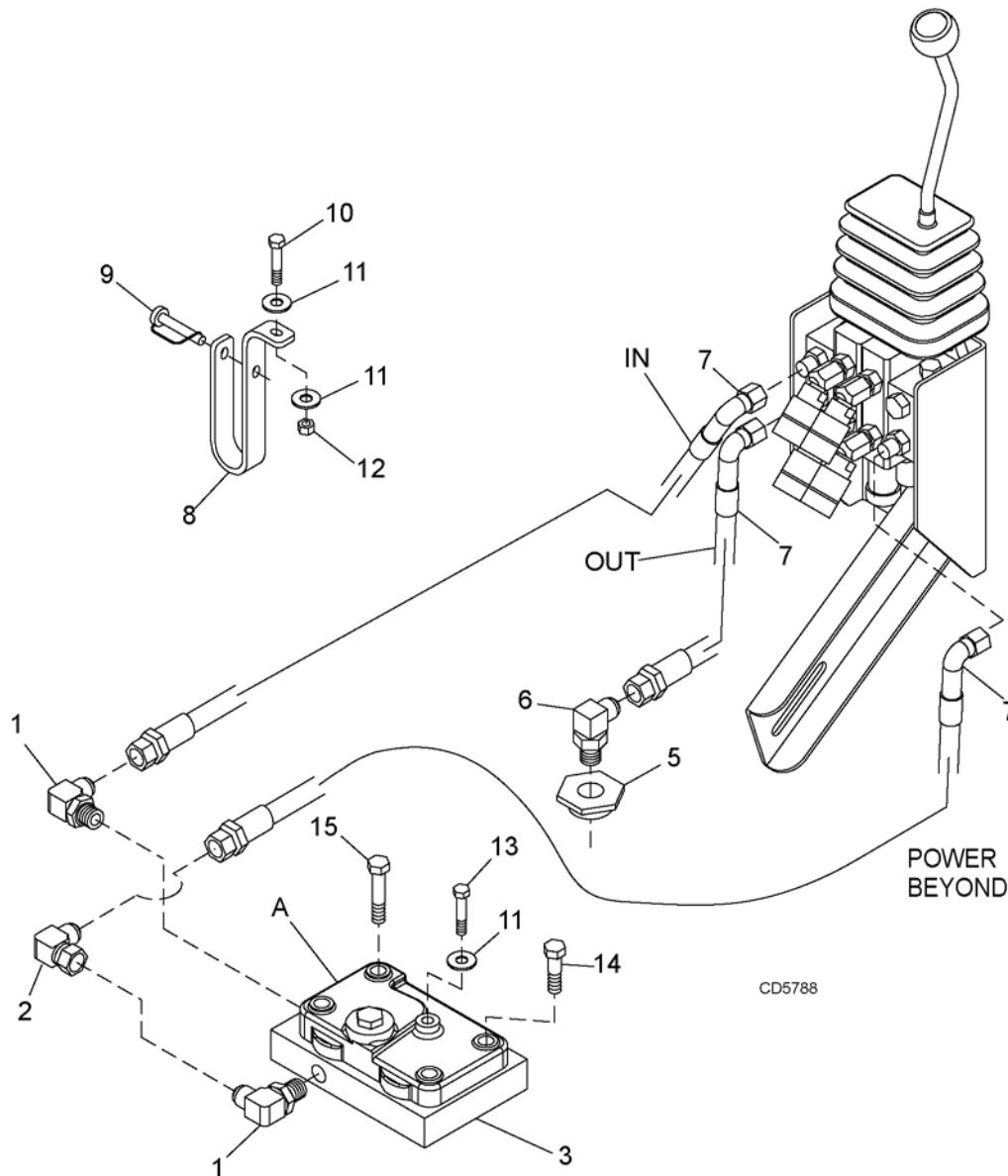

REF	PART	QTY	DESCRIPTION	REF	PART	QTY	DESCRIPTION
A	—	1	Accessory plate (tractor part)	10	6250 *	1	5/16 NC x 1-1/4 HHCS GR5
1	316004	2	Elbow, 3/4 JICM x 3/4 ORBM 90°	11	4378 *	3	5/16 Standard flat washer
2	313032	1	Elbow, 3/4 JICM x 3/4 JICF 90°	12	6778 *	1	5/16 NC Lock nut
3	1001421	1	Ford PBY Plate adapter	13	21548 *	1	5/16 NC x 3-1/4 HHCS GR8
5	1001419	1	Adapter, 7/8 O-ring F x 1-3/8 Trd M	14	21549 *	2	7/16 NC x 3 HHCS GR8 ZP
	- or -			15	1001423 *	2	7/16 NC x 4-3/4 HHCS GR8
5	1001657	1	Adapter, 7/8 O-ring F x 1-5/8 Trd M	16	88 *	4	Plastic tie (not shown)
6	60	1	Elbow, 3/4 JICM x 7/8 ORBM				
7	1001422	3	Hose, 86" x 3/4 JICF x 3/4 JICF				
8	58033	1	Hose hanger bracket				
9	58047	1	Pin lock 1/4 x 2-1/2				

HHCS Hex Head Cap Screw

* Standard hardware, obtain locally

22 Parts

MAN0064 (Rev. 7/20/2007)

1023582 HOSE KIT

(LU126 LOADER)

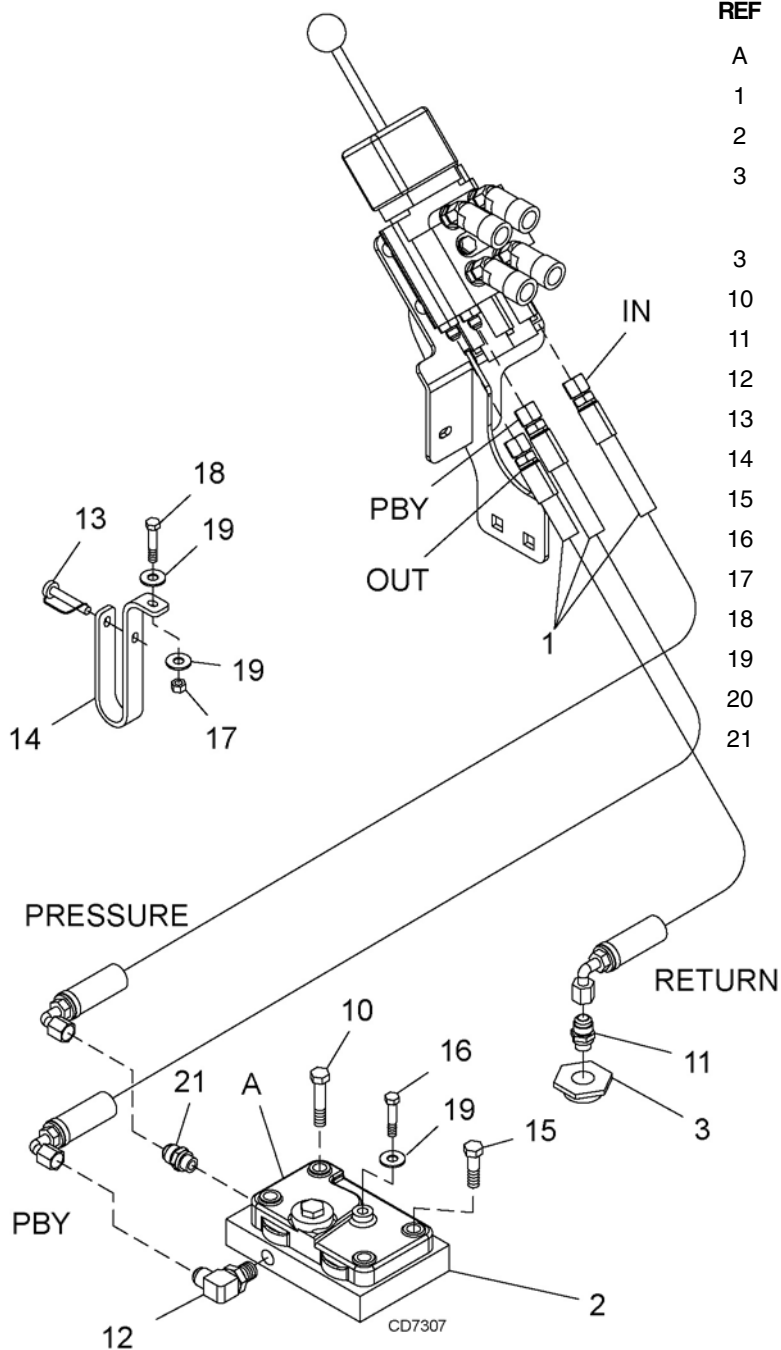

REF	PART	QTY	DESCRIPTION
A	—	1	Accessory plate (tractor part)
1	1001422	3	Hose, 86" x 3/4 JICF x 3/4 JICF
2	1001421	1	Ford PBYP Plate adapter
3	1001419	1	Adapter, 7/8 O-ring F x 1-3/8 Trd M
- or -			
3	1001657	1	Adapter, 7/8 O-ring F x 1-5/8 Trd M
10	1001423 *	2	7/16 NC x 4-3/4 HHCS GR8
11	316016	1	Adapter, 3/4 JICM x 7/8 ORBM
12	316004	1	Elbow, 3/4 JICM x 3/4 ORBM 90°
13	58047	1	Pin lock 1/4 x 2-1/2
14	58033	1	Hose hanger bracket
15	21549 *	2	7/16 NC x 3 HHCS GR8 ZP
16	21548 *	1	5/16 NC x 3-1/4 HHCS GR8
17	6778 *	1	5/16 NC Lock nut
18	6250 *	1	5/16 NC x 1-1/4 HHCS GR5
19	4378 *	3	5/16 Standard flat washer
20	88 *	4	Plastic tie (not shown)
21	61	1	Adapter, 3/4 JICM x 3/4 ORBM

HHCS Hex Head Cap Screw

* Standard hardware, obtain locally

57923 HOSE KIT

(10120/1027 LOADERS)

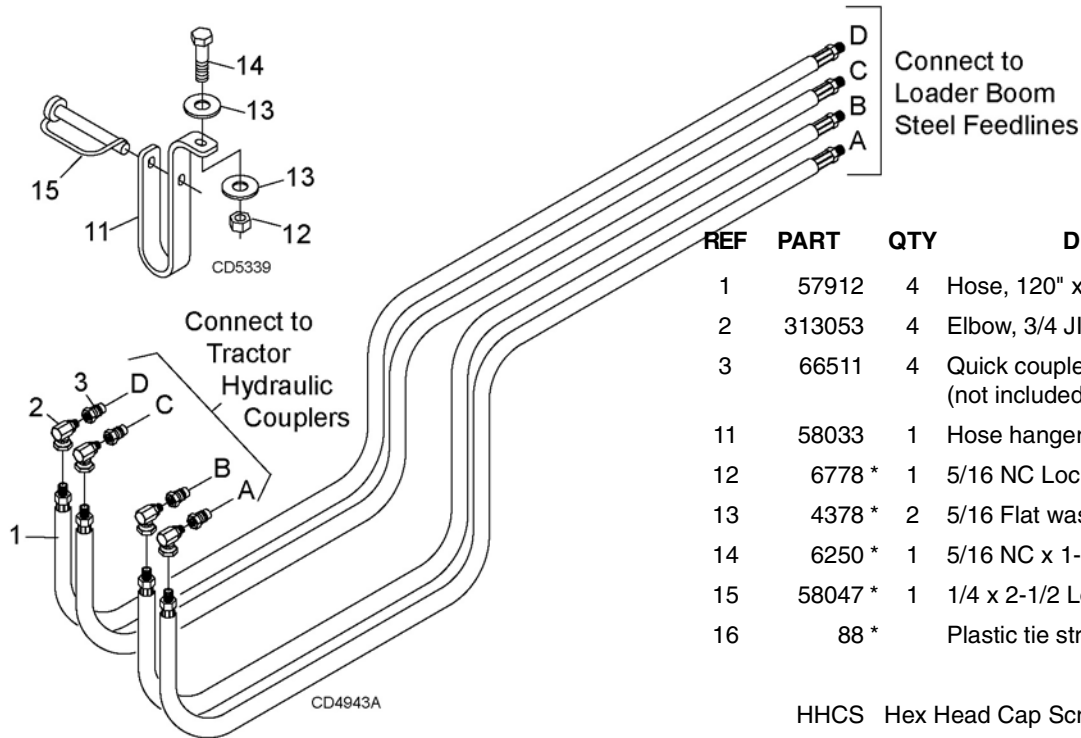

REF	PART	QTY	DESCRIPTION
1	57912	4	Hose, 120" x 3/4 JICM x 3/4 JICM
2	313053	4	Elbow, 3/4 JICF x 1/2 NPTM 90°
3	66511	4	Quick coupler, male 1/2 (not included in kit)
11	58033	1	Hose hanger bracket
12	6778 *	1	5/16 NC Lock nut
13	4378 *	2	5/16 Flat washer
14	6250 *	1	5/16 NC x 1-1/4 HHCS GR5
15	58047 *	1	1/4 x 2-1/2 Lock pin
16	88 *		Plastic tie straps (not shown)

HHCS Hex Head Cap Screw

* Standard hardware, obtain locally

1023596 HOSE KIT

(LU126 LOADER)

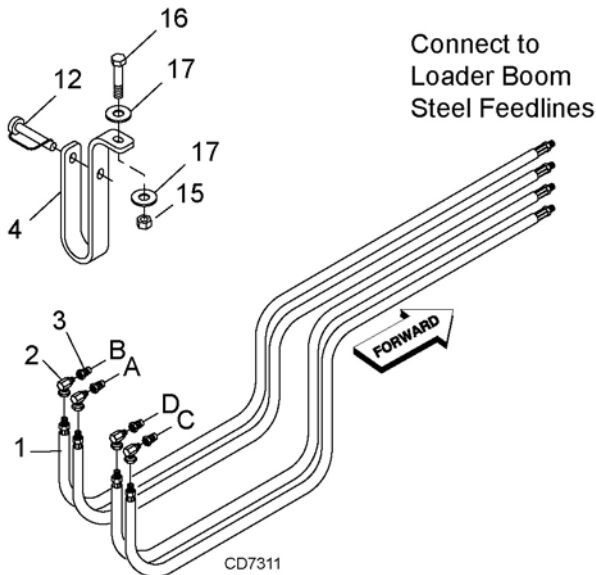

REF	PART	QTY	DESCRIPTION
1	1023472	4	Hose, 170" x 3/4 JICM x 3/4 JICM
2	313053	4	Elbow, 3/4 JICF x 1/2 NPTM 90°
3	66511	4	Quick coupler, male 1/2 (not included in kit)
4	58033	1	Hose hanger bracket
12	58047 *	1	1/4 x 2-1/2 Lock pin
15	6778 *	1	5/16 NC Lock nut
16	6250 *	1	5/16 NC x 1-1/4 HHCS GR5
17	4378 *	2	5/16 Flat washer
18	88 *		Plastic tie straps (not shown)

HHCS Hex Head Cap Screw

* Standard hardware, obtain locally

24 Parts

MAN0064 (Rev. 7/20/2007)

BOLT TORQUE CHART

Always tighten hardware to these values unless a different torque value or tightening procedure is listed for a specific application.

Fasteners must always be replaced with the same grade as specified in the manual parts list.

Always use the proper tool for tightening hardware: SAE for SAE hardware and Metric for metric hardware.

Make sure fastener threads are clean and you start thread engagement properly.

All torque values are given to specifications used on hardware defined by SAE J1701 MAR 99 & J1701M JUL 96.

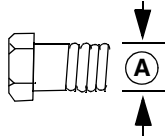

SAE SERIES TORQUE CHART



SAE Grade 2
(No Dashes)

SAE Bolt Head Identification



SAE Grade 5
(3 Radial Dashes)



SAE Grade 8
(6 Radial Dashes)

Ⓐ Diameter (Inches)	Wrench Size	MARKING ON HEAD					
		SAE 2		SAE 5		SAE 8	
		lbs-ft	N-m	lbs-ft	N-m	lbs-ft	N-m
1/4"	7/16"	6	8	10	13	14	18
5/16"	1/2"	12	17	19	26	27	37
3/8"	9/16"	23	31	35	47	49	67
7/16"	5/8"	36	48	55	75	78	106
1/2"	3/4"	55	75	85	115	120	163
9/16"	13/16"	78	106	121	164	171	232
5/8"	15/16"	110	149	170	230	240	325
3/4"	1-1/8"	192	261	297	403	420	569
7/8"	1-5/16"	306	416	474	642	669	907
1"	1-1/2"	467	634	722	979	1020	1383

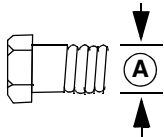

METRIC SERIES TORQUE CHART



Metric
Grade 8.8

Metric Bolt Head Identification



Metric
Grade 10.9

Ⓐ Diameter & Thread Pitch (Millimeters)	Wrench Size	COARSE THREAD				FINE THREAD				Ⓐ Diameter & Thread Pitch (Millimeters)
		MARKING ON HEAD								
		Metric 8.8		Metric 10.9		Metric 8.8		Metric 10.9		
		N-m	lbs-ft	N-m	lbs-ft	N-m	lbs-ft	N-m	lbs-ft	
6 x 1.0	10 mm	8	6	11	8	8	6	11	8	6 x 1.0
8 x 1.25	13 mm	20	15	27	20	21	16	29	22	8 x 1.0
10 x 1.5	16 mm	39	29	54	40	41	30	57	42	10 x 1.25
12 x 1.75	18 mm	68	50	94	70	75	55	103	76	12 x 1.25
14 x 2.0	21 mm	109	80	151	111	118	87	163	120	14 x 1.5
16 x 2.0	24 mm	169	125	234	173	181	133	250	184	16 x 1.5
18 x 2.5	27 mm	234	172	323	239	263	194	363	268	18 x 1.5
20 x 2.5	30 mm	330	244	457	337	367	270	507	374	20 x 1.5
22 x 2.5	34 mm	451	332	623	460	495	365	684	505	22 x 1.5
24 x 3.0	36 mm	571	421	790	583	623	459	861	635	24 x 2.0
30 x 3.0	46 mm	1175	867	1626	1199	1258	928	1740	1283	30 x 2.0

Typical Washer Installations

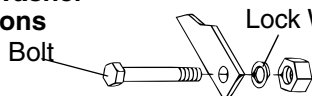

Lock Washer

Flat Washer



8/9/00

BOLT SIZE CHART

NOTE: Chart shows bolt thread sizes and corresponding head (wrench) sizes for standard SAE and metric bolts.

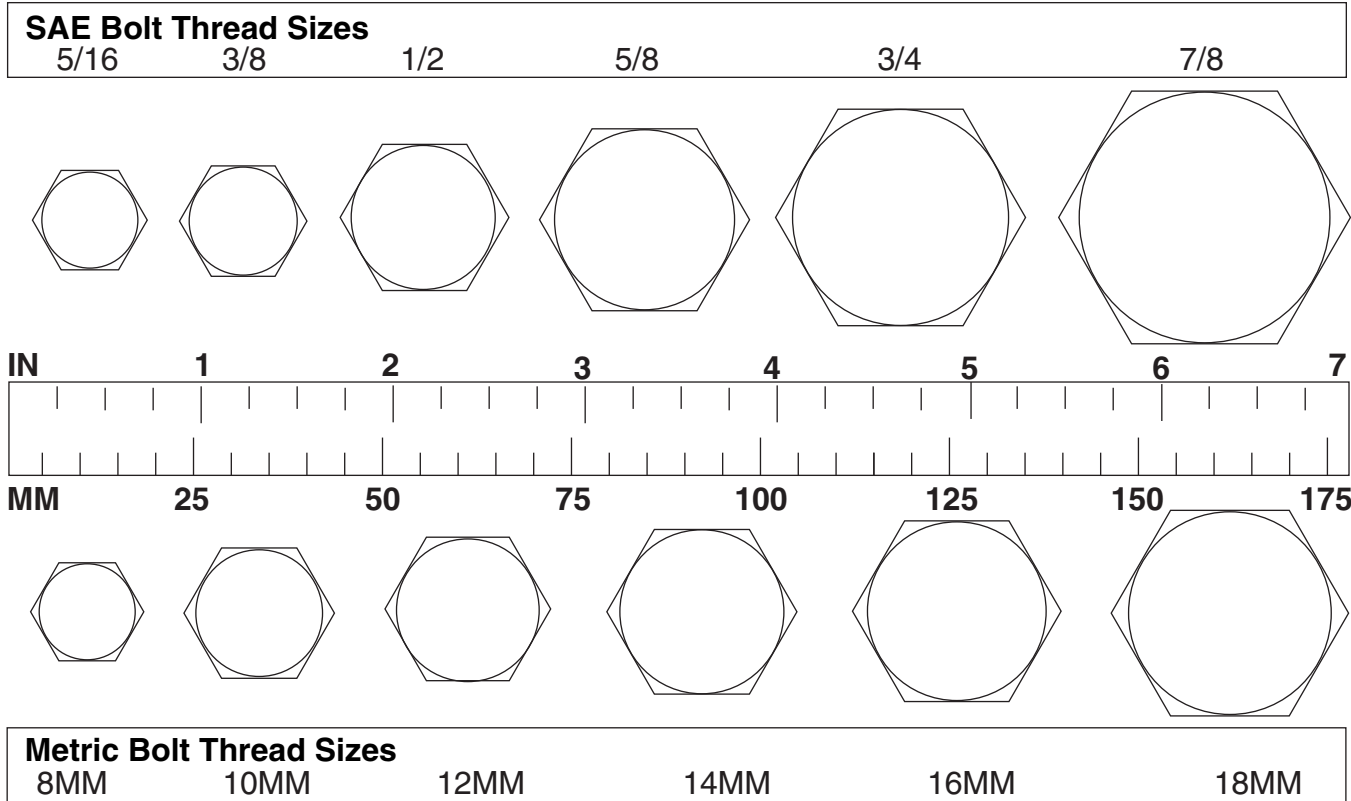

ABBREVIATIONS

AG Agriculture
 ASABE American Society of Agricultural & Biological Engineers (formerly ASAE)
 ASAE..... American Society of Agricultural Engineers
 ATF.....Automatic Transmission Fluid
 BSPP..... British Standard Pipe Parallel
 BSPTM..... British Standard Pipe Tapered Male
 CV Constant Velocity
 CCW..... Counter-Clockwise
 CW Clockwise
 F Female
 FT..... Full Thread
 GA Gauge
 GR (5, etc.)..... Grade (5, etc.)
 HHCS Hex Head Cap Screw
 HT Heat-Treated
 JIC..... Joint Industry Council 37° Degree Flare
 LH..... Left Hand
 LT Left
 m Meter
 mm Millimeter
 M Male

MPa Mega Pascal
 N Newton
 NC..... National Coarse
 NF National Fine
 NPSM National Pipe Straight Mechanical
 NPT.....National Pipe Tapered
 NPT SWF..... National Pipe Tapered Swivel Female
 ORBM O-Ring Boss - Male
 P Pitch
 PBY.....Power-Beyond
 psi Pounds per Square Inch
 PTO.....Power Take Off
 QD Quick Disconnect
 RH..... Right Hand
 ROPS..... Roll-Over Protective Structure
 RPM.....Revolutions Per Minute
 RT Right
 SAE..... Society of Automotive Engineers
 UNC Unified Coarse
 UNF Unified Fine
 UNS Unified Special



WARRANTY

All Models Except Mow'n Machine™ Zero-Turn Mowers

Please Enter Information Below and Save for Future Reference.

Date Purchased: _____ From (Dealer): _____

Model Number: _____ Serial Number: _____

Woods Equipment Company ("WOODS") warrants this product to be free from defect in material and workmanship. Except as otherwise set forth below, the duration of this Warranty shall be for TWELVE (12) MONTHS COMMENCING ON THE DATE OF DELIVERY OF THE PRODUCT TO THE ORIGINAL PURCHASER.

All current model loaders and backhoes are warranted for two (2) years from the date of delivery to the original purchaser.

The warranty periods for specific parts or conditions are listed below:

Part or Condition Warranted	Model Number	Duration (from date of delivery to the original purchaser)
Gearbox Seals	All units listed below	2 years
Gearbox components	BW1260, BW1620, BW1800, BW2400	8 years
	BW240HD, BW180HD, BW180HB, BW126HB	7 years
	BB48X, BB60X, BB72X, BB84X, BB600X, BB720X, BB840X, BB6000X, BB7200X, BB8400X, DS1260, DSO1260, DS1440, TS1680, BW126-3, BW180-3, BW240	6 years
	PHD25, PHD35, PHD65, PHD95, 2162, 3240, DS96, DS120, RCC42, RM550-2, RM660-2, RM990-3, PRD6000, PRD7200, PRD8400, 7144RD-2, 9180RD-2, 9204RD-2, S15CD, S20CD, S22CD, S25CD, S27CD, BW180LH, TC/R74, TC/R68, TC/R60	5 years
	RDC54, RD60, RD72, TBW150C, TS/R60, TS/R52, TS/R44	3 years (1 year if used in rental or commercial applications)
Blade spindles	RM550-2, RM660-2, RM990-3, PRD6000, PRD7200, PRD8400, 7144RD-2, 9180RD-2, 9204RD-2	3 years
Rust-through	BB600, BB720, BB840, BB6000, BB7200, BB8400, BW126-3, BW126HB, BW180-3, BW180HB, BW180HD, BW1260, BW1800, BW240, BW240HD, 2162, 3240, DS1260, DSO1260, DS1440, TS1680	10 years

Under no circumstances will this Warranty apply in the event that the product, in the good faith opinion of WOODS, has been subjected to improper operation, improper maintenance, misuse, or an accident. This Warranty does not apply in the event that the product has been materially modified or repaired by someone other than WOODS, a WOODS authorized dealer or distributor, and/or a WOODS authorized service center. This Warranty does not cover normal wear or tear, or normal maintenance items. This Warranty also does not cover repairs made with parts other than those obtainable through WOODS.

This Warranty is extended solely to the original purchaser of the product. Should the original purchaser sell or otherwise transfer this product to a third party, this Warranty does not transfer to the third party purchaser in any way. There are no third party beneficiaries of this Warranty.

WOODS makes no warranty, express or implied, with respect to engines, batteries, tires or other parts or accessories not manufactured by WOODS. Warranties for these items, if any, are provided separately by their respective manufacturers.

WOODS' obligation under this Warranty is limited to, at WOODS' option, the repair or replacement, free of charge, of the product if WOODS, in its sole discretion, deems it to be defective or in noncompliance with this Warranty. **The product must be returned to WOODS with proof of purchase within thirty (30) days after such defect or noncompliance is discovered or should have been discovered, routed through the dealer and distributor from whom the purchase was made, transportation charges prepaid.** WOODS shall complete such repair or replacement within a reasonable time after WOODS receives the product. **THERE ARE NO OTHER REMEDIES UNDER THIS WARRANTY. THE REMEDY OF REPAIR OR REPLACEMENT IS THE SOLE AND EXCLUSIVE REMEDY UNDER THIS WARRANTY.**

THERE ARE NO WARRANTIES WHICH EXTEND BEYOND THE DESCRIPTION ON THE FACE OF THIS WARRANTY. WOODS MAKES NO OTHER WARRANTY, EXPRESS OR IMPLIED, AND WOODS SPECIFICALLY DISCLAIMS ANY IMPLIED WARRANTY OF MERCHANTABILITY AND/OR ANY IMPLIED WARRANTY OF FITNESS FOR A PARTICULAR PURPOSE.

WOODS shall not be liable for any incidental or consequential losses, damages or expenses, arising directly or indirectly from the product, whether such claim is based upon breach of contract, breach of warranty, negligence, strict liability in tort or any other legal theory. Without limiting the generality of the foregoing, Woods specifically disclaims any damages relating to (i) lost profits, business, revenues or goodwill; (ii) loss of crops; (iii) loss because of delay in harvesting; (iv) any expense or loss incurred for labor, supplies, substitute machinery or rental; or (v) any other type of damage to property or economic loss.

This Warranty is subject to any existing conditions of supply which may directly affect WOODS' ability to obtain materials or manufacture replacement parts.

No agent, representative, dealer, distributor, serviceperson, salesperson, or employee of any company, including without limitation, WOODS, its authorized dealers, distributors, and service centers, is authorized to alter, modify, or enlarge this Warranty. Answers to any questions regarding warranty service and locations may be obtained by contacting:

Woods Equipment Company

2606 South Illinois Route 2
Post Office Box 1000
Oregon, Illinois 61061 USA

800-319-6637 tel
800-399-6637 fax
www.WoodsEquipment.com



ALITEC™

BMP®

CENTRAL FABRICATORS®

GANNON®

GILL®

WAIN-ROY®

WOODS®



WARRANTY

(Replacement Parts For All Models Except Mow'n Machine™
Zero-Turn Mowers and Woods Boundary™ Utility Vehicles)

Woods Equipment Company ("WOODS") warrants this product to be free from defect in material and workmanship for a period of ninety (90) days from the date of delivery of the product to the original purchaser with the exception of V-belts, which will be free of defect in material and workmanship for a period of 12 months.

Under no circumstances will this Warranty apply in the event that the product, in the good faith opinion of WOODS, has been subjected to improper operation, improper maintenance, misuse, or an accident. This Warranty does not cover normal wear or tear, or normal maintenance items.

This Warranty is extended solely to the original purchaser of the product. Should the original purchaser sell or otherwise transfer this product to a third party, this Warranty does not transfer to the third party purchaser in any way. There are no third party beneficiaries of this Warranty.

WOODS' obligation under this Warranty is limited to, at WOODS' option, the repair or replacement, free of charge, of the product if WOODS, in its sole discretion, deems it to be defective or in noncompliance with this Warranty. **The product must be returned to WOODS with proof of purchase within thirty (30) days after such defect or noncompliance is discovered or should have been discovered, routed through the dealer and distributor from whom the purchase was made, transportation charges prepaid.** WOODS shall complete such repair or replacement within a reasonable time after WOODS receives the product. THERE ARE NO OTHER REMEDIES UNDER THIS WARRANTY. THE REMEDY OF REPAIR OR REPLACEMENT IS THE SOLE AND EXCLUSIVE REMEDY UNDER THIS WARRANTY.

THERE ARE NO WARRANTIES WHICH EXTEND BEYOND THE DESCRIPTION ON THE FACE OF THIS WARRANTY. WOODS MAKES NO OTHER WARRANTY, EXPRESS OR IMPLIED, AND WOODS SPECIFICALLY DISCLAIMS ANY IMPLIED WARRANTY OF MERCHANTABILITY AND/OR ANY IMPLIED WARRANTY OF FITNESS FOR A PARTICULAR PURPOSE.

WOODS shall not be liable for any incidental or consequential losses, damages or expenses, arising directly or indirectly from the product, whether such claim is based upon breach of contract, breach of warranty, negligence, strict liability in tort or any other legal theory. Without limiting the generality of the foregoing, Woods specifically disclaims any damages relating to (i) lost profits, business, revenues or goodwill; (ii) loss of crops; (iii) loss because of delay in harvesting; (iv) any expense or loss incurred for labor, supplies, substitute machinery or rental; or (v) any other type of damage to property or economic loss.

This Warranty is subject to any existing conditions of supply which may directly affect WOODS' ability to obtain materials or manufacture replacement parts.

No agent, representative, dealer, distributor, service person, salesperson, or employee of any company, including without limitation, WOODS, its authorized dealers, distributors, and service centers, is authorized to alter, modify, or enlarge this Warranty.

Answers to any questions regarding warranty service and locations may be obtained by contacting:

ALITEC™
BMP®
CENTRAL FABRICATORS®
GANNON®
GILL®
WAIN-ROY®
WOODS®

WOODS®

**Woods Equipment
Company**

2606 South Illinois Route 2
Post Office Box 1000
Oregon IL 61061

800-319-6637 tel
800-399-6637 fax
www.WoodsEquipment.com