



Master Series Heavy Duty Front-Fired Hot Top Range

Item: _____
 Quantity: _____
 Project: _____
 Approval: _____
 Date: _____

Master Series Heavy Duty Front-Fired Hot Top Range

Models:

- MST45R MST45S MST45T MST45R-E MST45S-E MST45T-E

Two Front-Fired Hot Top Range



Model MST45R
(valve control panel not as depicted)

Standard Features:

- Stainless steel front and sides
- 6" (152mm) chrome steel adj. legs
- 7-1/2" (191mm) stainless steel front rail
- Two extra-heavy cast iron top sections, each with 3 individually controlled jet burners rated 40,000 BTU (11.71 kW) total, 30,000 BTU (8.78kW) for CSA approved propane models
- Removable cast iron ring and lid
- Heavy gauge, aluminized steel radiation baffle system
- 1-piece Stainless Steel drip tray
- Piezo spark ignition for oven
- Fully porcelainized oven interior
- 40,000 BTU (11.72 kW) natural gas, 35,000 BTU (10.25 kW) propane gas, cast iron oven burner
- Storage base interior of aluminized steel w/shelf (suffix S)
- Modular top available (suffix T)
- Electric Spark ignition on all pilots
Suffix -E models
- Sentry total flame failure protection for all burners

Optional Features:

- Gas regulator 3/4" or 1-1/4"

- Gas shut off valve; 3/4", 1" or 1-1/4" NPT
- Gas flex hose & quick disconnect (3/4", 1" or 1-1/4" NPT x 5') w/restraining device, please specify
- Stainless steel main back
- Stainless steel common front rail up to 68" (1728mm) wide (two or more units in a battery)
- Stainless steel oven interior
- Additional oven racks
- Rear gas connection, 3/4" or 1-1/4" NPT; exterior mount, left or right, add 5-1/4"(133mm) to range width
- End caps and cover, (NC, specify)
- 4-Swivel casters w/front brakes
- 4-Polyurethane non-marking swivel casters w/front brakes
- 6" (152mm) stainless steel adj. legs
- Dais base (not for use with "RC" oven)
- Storage base shelf of stainless steel
- Stainless steel tubular high shelf, single or double deck
- Stainless steel backguard: 10" (354mm), 17" (432mm) or 33" (838mm)
- 230 volt, 50 Hz for electric spark ignition
- Celsius dial for oven thermostat (NC)

Specifications:

Heavy-duty gas range with oven, Model MST45R. Two (2) 17" (432mm) front fired spectro-heat hot tops, total 80,000 BTU (23.42 kW). Sentry total flame failure protection for all burners 34" (864mm) wide x 38" (965mm) deep, including 7-1/2" (191mm) deep stainless steel front rail. Porcelain enamel oven with 40,000 BTU (11.72 kW) cast iron burner. Stainless steel front and sides. 120,000 BTU 35.14kW total for natural gas. Also available with storage base w/ doors, suffix S, and modular top, suffix T.



NOTE: Ranges supplied with casters must be installed with an approved restraining device.

Garland Commercial Ranges Ltd.
 1177 Kamato Road,
 Mississauga, Ontario
 L4W 1X4 CANADA

General Inquires 1-905-624-0260
 USA Sales, Parts and Service 1-800-424-2411
 Canadian Sales 1-888-442-7526
 Canada or USA Parts/Service 1-800-427-6668



Product	Width: In(mm)	Depth: In(mm)	Height: In(mm) (w/ NSF Legs)	Height: In(mm) (w/o NSF Legs)	Oven/Storage Base Interior: in(mm)		
					Width	Depth	Height
MST45R	34(864)	38(965)	36-3/8(924)	30-3/8(772)	26-1/4(667)	29(737)	13-1/2(343)
MST45S	34(864)	38(965)	36-3/8(924)	36-3/8(924)	26(665)	30-1/2(773)	20-1/2(519)
MST45T	34(864)	38(965)	36-3/8(924) w/stand	9-1/2 (241) w/o stand*	N/A	N/A	N/A

*Modular top has 1-1/2" seating flanges.

INPUT-BTU/hr	MST45R		MST45S & MST45T	
	Natural	Propane	Natural	Propane
Total Top Section: CE Approved Models	80,000 (23.42kW)	80,000 (23.42kW)	80,000 (23.42kW)	80,000 (23.42kW)
Total Top Section: CSA Approved Models	80,000 (23.42kW)	60,000 (17.57kW)	80,000 (23.42kW)	60,000 (17.57kW)
Oven: CE and CSA Approved Models	40,000 (11.71kW)	35,000 (10.25kW)	N/A	N/A

R=Range w/Oven S=Range w/Storage Base T=Modular Top

INSTALLATION NOTES			Shipping Wt: (Lb/Kg) ²
Combustible Wall Clearances ¹	Entry Clearances	Operating Pressure	
Sides: 14" (356mm) Back: 6" (152mm)	Crated: 39-1/4" (997mm) Uncrated: 34-1/4" (870mm)	Natural: 6" WC (15mbar) Propane: 10" WC (25mbar)	MST45R 510/232 MST45S 410/186 MST45T 305/138

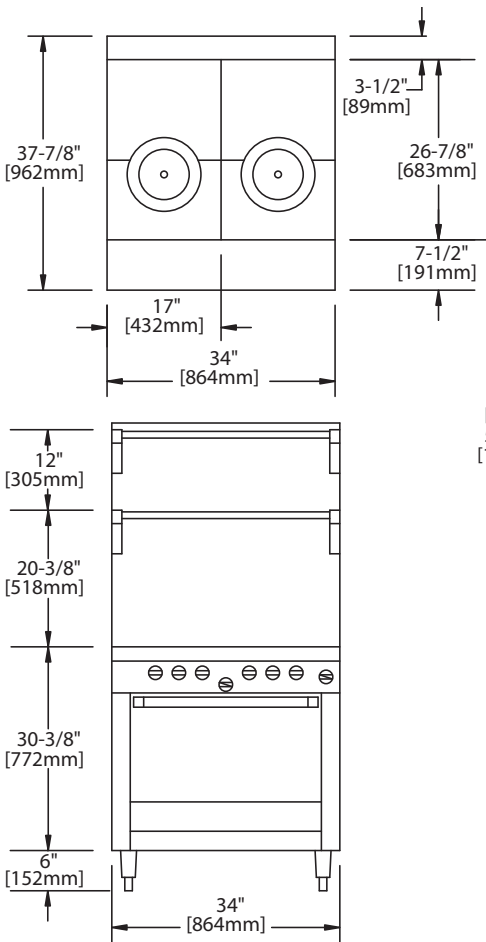

¹NOTE: Installation clearance reductions are applicable only where local codes permit.

²Shipping Cubic Feet 50 for R & S Models, 20 for T models

Gas input ratings shown here are for installations up to 2,000 ft. (610m) above sea level. Specify altitudes over 2,000 ft.

Electrical characteristics for models with suffix "E"

120 VAC single phase 0.1 amps, C/W power cord with NEMA 5-15P plug.

230 VAC 50 Hz units 0.05 amps, must be direct connect.

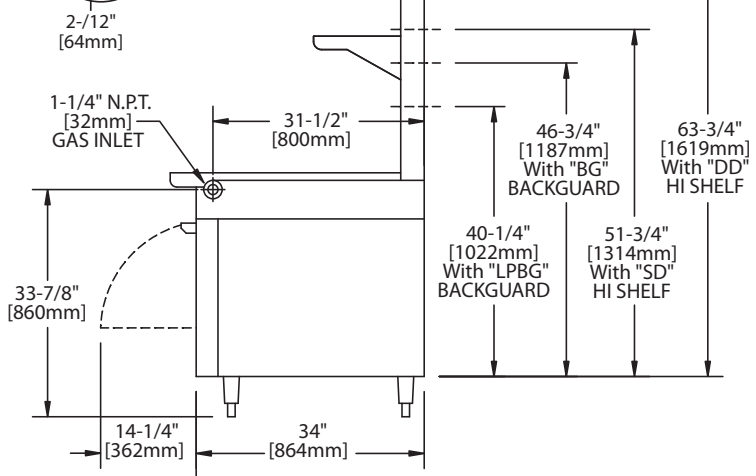
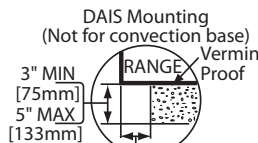

Form# MST45 (02/16/12)