

**Robin Industrial Engines®**

# **PARTS MANUAL**

**Model**

**PKX201**

**PUMP**

PUB-PP5872  
Rev. 08/07

**Robin**  
SUBARU

# **Robin America, Inc.**

940 Lively Blvd. • Wood Dale, IL 60191 • Phone: 630-350-8200 • Fax: 630-350-8212  
e-mail: [sales@robinamerica.com](mailto:sales@robinamerica.com) • [www.robinamerica.com](http://www.robinamerica.com)

© Copyright 2003 Robin America, Inc.

## HOW TO USE THIS MANUAL

Robin engines are identified by MODEL, SPECIFICATION, and CODE NUMBER. For each model there may be many different versions called specifications. Each specification will be unique in some way. The difference may only be the paint color or it may have a different type of PTO or some other significant difference.

In order to identify the correct service part number, it is important to confirm the specification and code numbers for your engine. The specification and code number together are known as the PRODUCT NUMBER.

All Robin 4 cycle engines have a Product Number label similar to the label illustrated below.

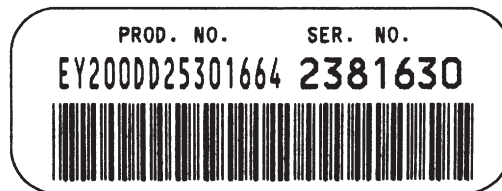
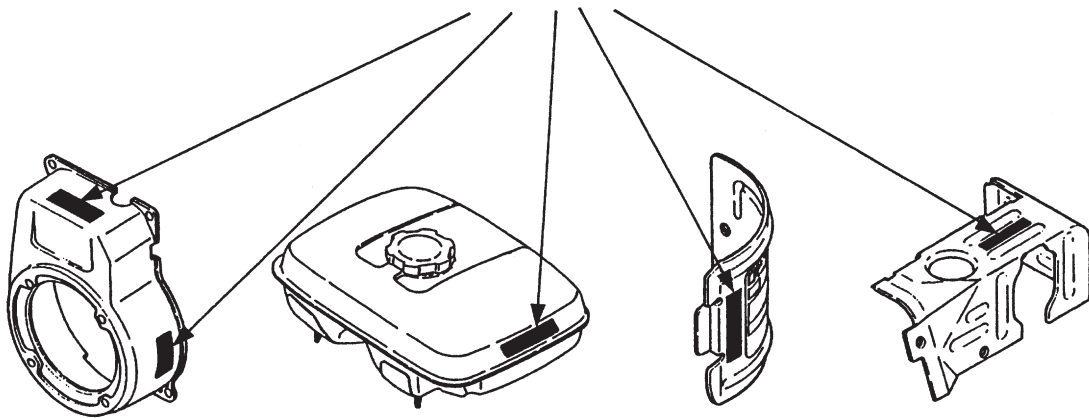

The Product Number Label has a 15 digit alphanumeric string that consists of the SPECIFICATION (SPEC) number (11 digits) and the CODE number (4 digits). Please note the illustration below:

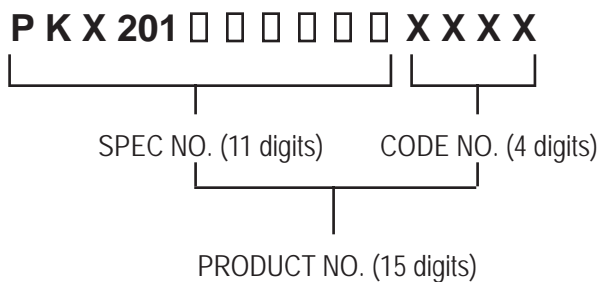

# MANUAL LAYOUT

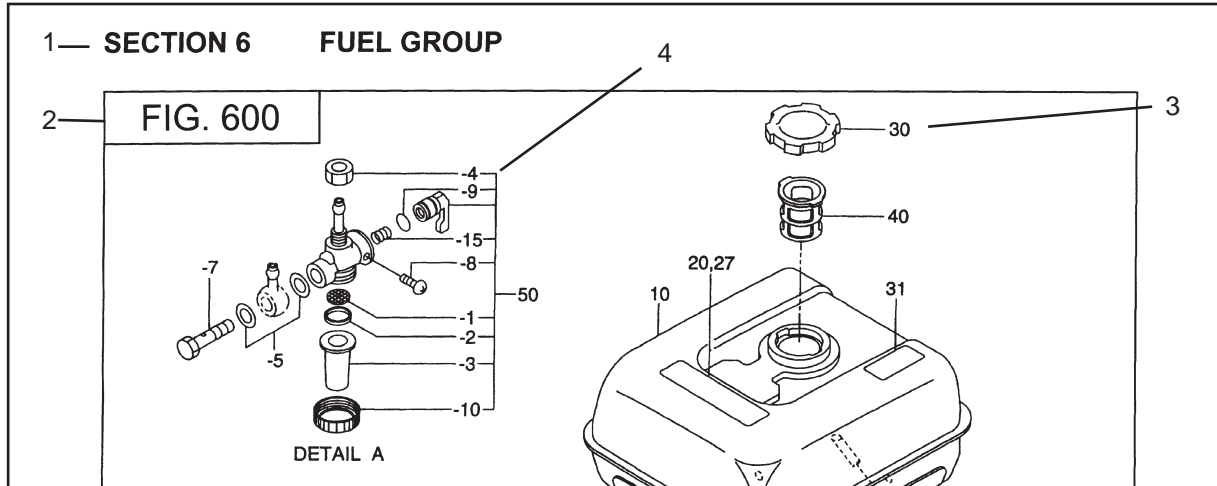

REF.	PART NO.	DESCRIPTION	QTY.	REMARKS	FROM-TO	FIG.
10	267-60103-01	FUEL TANK CP	1	YD, YS TYPE, BLACK		600
	267-60101-01	FUEL TANK CP	1	YELLOW		600
27	073-20039-00	LABEL, WARNING	1	YD, YS TYPE		600
30	043-04300-15	FUEL TANK CAP CP	1			600
31	267-95201-03	LABEL, EMISSION	1	YD, YS TYPE		600
40	064-13600-10	FUEL FILTER	1			600
50	064-20021-01	FUEL STRAINER AY	1			600
-1	064-20002-20	FILTER	1			600
-2	064-20002-30	GASKET	1			600
-3	064-20019-10	CUP	1			600

1. SECTION NAME      Parts are broadly classified according to their functions. Refer to the Group Index (table of contents) for respective section name.
2. FIG. No.            The FIG. number indexes the reference and part numbers to the illustration. Figure numbers that vary only in the tens place (i.e.: 700 and 710) are in a group of the same section (i.e.:Electrical Device Group).
3. REF. No .          The Reference number identifies the part illustration with the corresponding part number in the part list.
4. SUBASSEMBLY      SUBASSEMBLY parts of part assembly are listed below the assembly part. The subassembly part reference number is indicated by the number led by "-" such as "-1", "-2".
5. PART NUMBER      It is the number assigned for sales unit. Use the PART No. when making an order.
6. DESCRIPTION      It is designation of the part.
7. QTY.                Quantity of each part used for each product.
8. REMARKS            This gives a distinctive feature and/or a supplementary comment for the type, the specification, and the part concerned. It also shows part number(s) interchangeable for the part.
9. FROM-TO          This section shows the CODE No. to indicate the history of progress in which improved parts have been introduced in the product. The FROM-TO CODE No. helps to identify PART No. being employed in the product concerned. See the examples below:
  - The part is used in the product irrespective of CODE No.
  - 2101-                The part is used in the products with CODE No. of 2101 and after this number.
  - 2100                The part is used in the products with CODE No. of 2100 and before this number.

# GROUP INDEX

Group Name	Page
PUMP .....	6
CRANKCASE GROUP .....	8
CRANKSHAFT GROUP .....	10
INTAKE and EXHAUST GROUP .....	12
GOVERNOR GROUP .....	16
COOLING and STARTING GROUP .....	18
FUEL, LUBRICANT GROUP .....	20
CARBURETOR GROUP .....	22
ELECTRIC DEVICE GROUP .....	24
ACCESSORY GROUP .....	26

INDEX OF DESCRIPTION SYMBOLS			
SYMBOL	DESCRIPTION	SYMBOL	DESCRIPTION
AY .....	ASSEMBLY	P= .....	PITCH (in mm)
CP .....	COMPLETE	P.T.O. (PTO) .....	POWER TAKE OFF
EX .....	EXPORT (from Japan)	REF .....	REFERENCE
FIG .....	FIGURE	R.H. (RH) .....	RIGHT HAND SIDE
FR .....	FRONT	RR .....	REAR
" .....	INCH	STD. ....	STANDARD
INCL. ....	INCLUDE	SW .....	SWITCH
-L .....	LITER	T= .....	THICKNESS (in mm)
L= .....	LENGTH (in. mm)	UN .....	UNIT
L.H. (LH) .....	LEFT-HAND SIDE	U.S. ....	UNDER SIZE
MECH .....	MECHANICAL	~V .....	VOLTAGE
NO (NON) .....	NONE	~W .....	WATT
OPT .....	OPTIONAL	W/ .....	WITH
O.S. ....	OVER SIZE	W/O .....	WITHOUT

SECTION 1 PUMP GROUP

FIG. 100

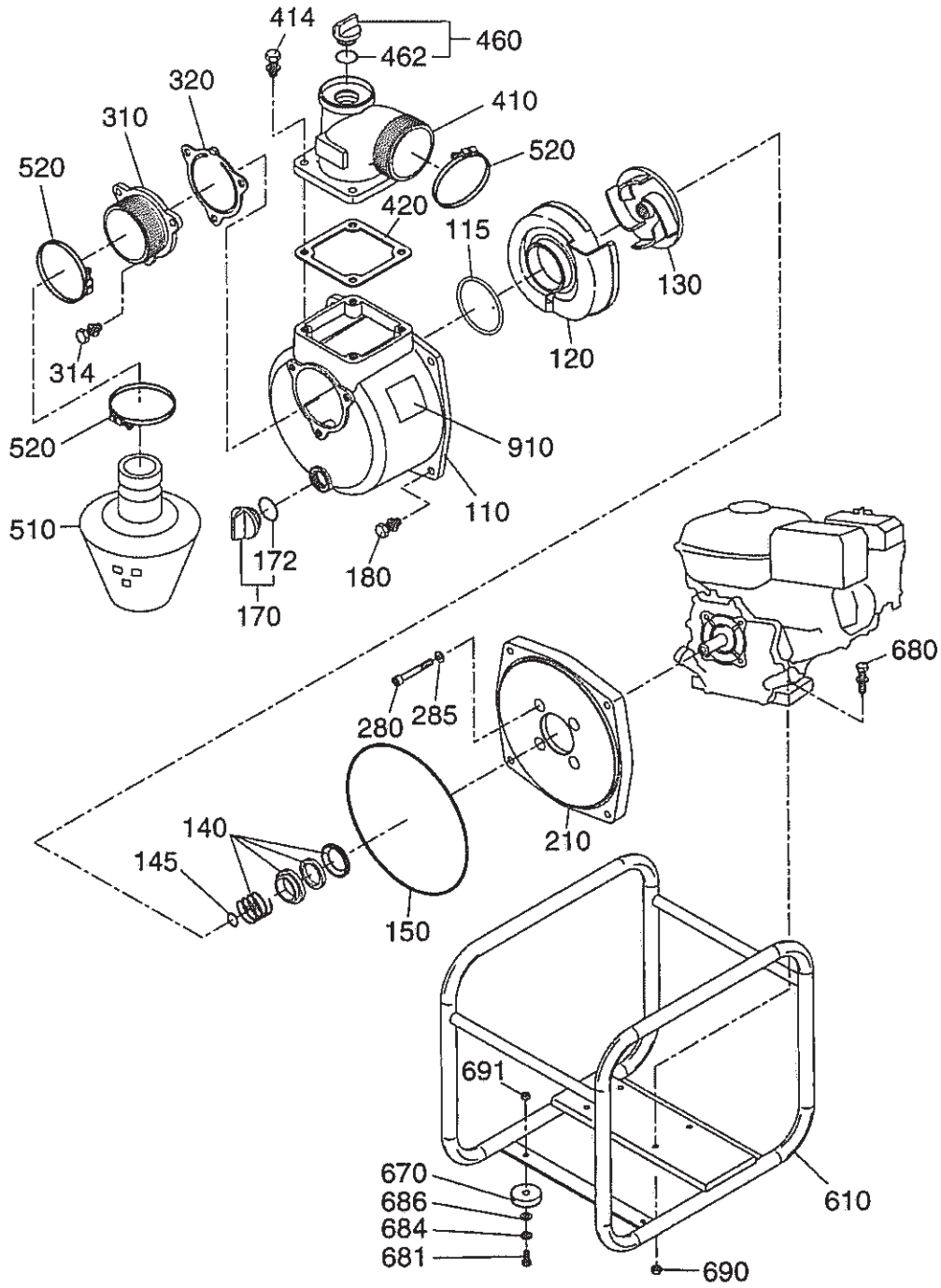

# SECTION 1 PUMP GROUP

REF.	PART NO.	DESCRIPTION	QTY.	REMARKS	FROM-TO	FIG.
110	470-01125-78	CASING	1			100
115	470-01127-92	O RING	1			100
120	470-01146-40	INNER CASING	1			100
130	470-01135-32	IMPELLER	1			100
140	470-01106-88	MECHANICAL SEAL	1			100
145	470-01104-66	ADJUSTING WASHER	3			100
150	470-01150-14	O RING	1			100
170	470-01180-78	PLUG AY	1			100
172	471-00000-05	O RING	1			100
180	471-00000-62	BOLT and WASHER AY	4			100
210	470-01125-79	FLANGE BRACKET	1			100
280	471-00000-03	SOCKET BOLT	4			100
285	471-00000-02	SEAL WASHER	4			100
310	470-01128-22	SUCTION FLANGE	1			100
314	471-00000-64	BOLT and WASHER AY	3			100
320	470-01126-65	CHECK VALVE	1			100
410	470-01158-61	DELIVERY FLANGE	1			100
414	471-00000-72	BOLT and WASHER AY	4			100
420	470-01105-41	PACKING, delivery	1			100
460	470-01180-78	PLUG AY	1			100
462	471-00000-05	O RING	1			100
510	470-01181-59	STRAINER	1			100
520	471-00000-01	HOSE BAND	3			100
610	470-01176-93	FRAME	1			100
670	470-01105-15	CUSHION RUBBER	4			100
680	471-00000-70	BOLT and WASHER AY	4			100
681	471-00000-71	BOLT and WASHER AY	4			100
684	471-00000-68	SPRING WASHER	4			100
686	471-00000-66	WASHER	4			100
690	471-00000-57	NUT	4			100
691	471-00000-57	NUT	4			100
910	470-01165-57	LABEL, pump name	1			100

SECTION 2 CRANKCASE GROUP

FIG. 200

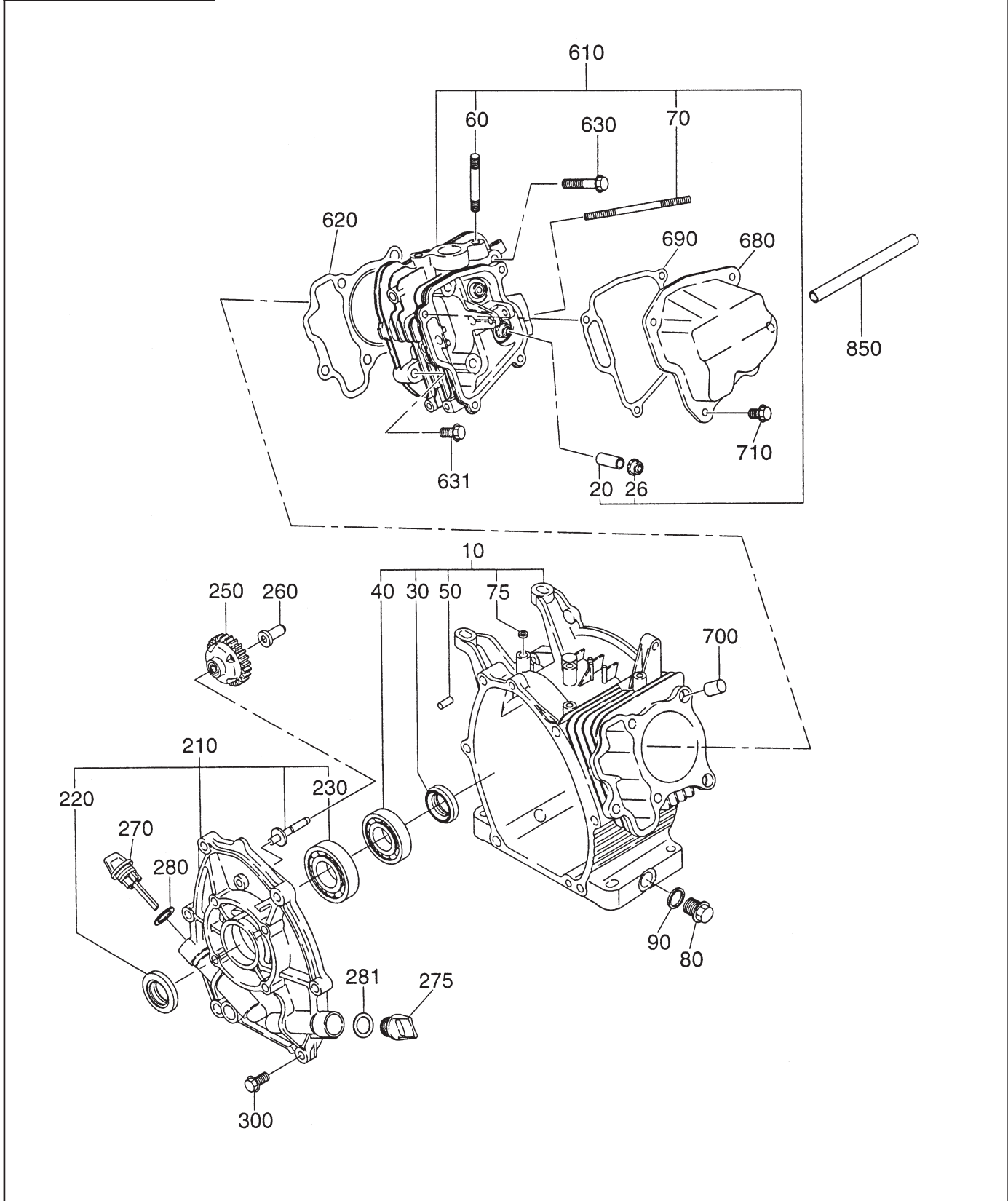



**SECTION 2      CRANKCASE GROUP**

REF.	PART NO.	DESCRIPTION	QTY.	REMARKS	FROM-TO	FIG.
10	276-10102-41	CRANKCASE CP	1	W/ OIL SENSOR	5692~	200
	276-10102-21	CRANKCASE CP	1	W/ OIL SENSOR	~5691	200
20	237-14201-03	VALVE GUIDE	2			200
26	277-16010-01	STEM SEAL	1			200
30	044-02502-00	OIL SEAL	1			200
40	060-02800-21	BALL BEARING	1		5723~	200
	060-02800-20	BALL BEARING	1		~5722	200
50	277-15011-03	PIPE KNOCK	2			200
60	010-50802-50	STUD	2			200
70	010-50603-51	STUD	2			200
75	044-00600-20	OIL SEAL	1			200
80	040-11400-30	PLUG	2			200
90	021-11400-20	GASKET	2			200
210	277-11001-31	MAIN BEARING COVER	1		5692~	200
	277-11001-21	MAIN BEARING COVER	1		5753~5691	200
	277-11001-11	MAIN BEARING COVER	1		~5752	200
220	044-02502-10	OIL SEAL	1			200
230	060-02501-40	BALL BEARING	1		5753~	200
	060-02500-10	BALL BEARING	1		~5752	200
250	277-45004-21	GOVERNOR GEAR CP	1			200
260	263-41901-03	GOVERNOR SLEEVE	1			200
270	277-63601-13	OIL GAUGE	1			200
275	277-65001-03	FILLER PLUG	1			200
280	021-31600-20	GASKET	1			200
281	021-31600-20	GASKET	1			200
300	001-04083-50	FLANGE BOLT	6			200
610	276-13001-01	CYLINDER HEAD CP	1			200
620	276-15001-13	GASKET, head	1			200
630	011-00802-40	FLANGE BOLT	4			200
631	001-04083-50	FLANGE BOLT	1			200
680	277-15501-01	ROCKER COVER CP	1			200
690	277-16001-03	GASKET, rocker cover	1			200
700	277-15011-03	PIPE KNOCK	2			200
710	011-00600-20	FLANGE BOLT	4			200
850	085-10800-00	RUBBER PIPE	1			200
960	276-99001-07	GASKET SET	1			200

Gasket Sets include the following:  
 Fig. 200 items 90, 280, 620 and 690  
 Fig. 400 items 340 and 550

SECTION 3 CRANKSHAFT GROUP

FIG. 300

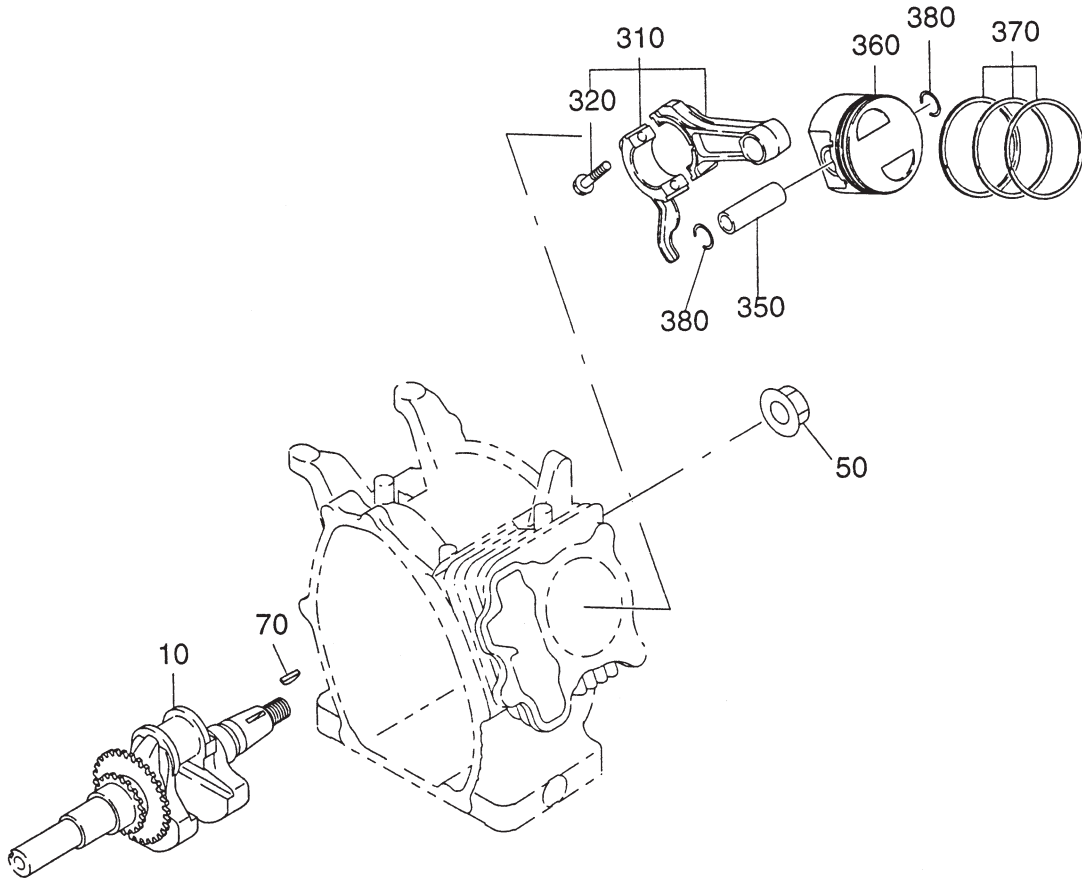



SECTION 4 INTAKE and EXHAUST GROUP

FIG. 400

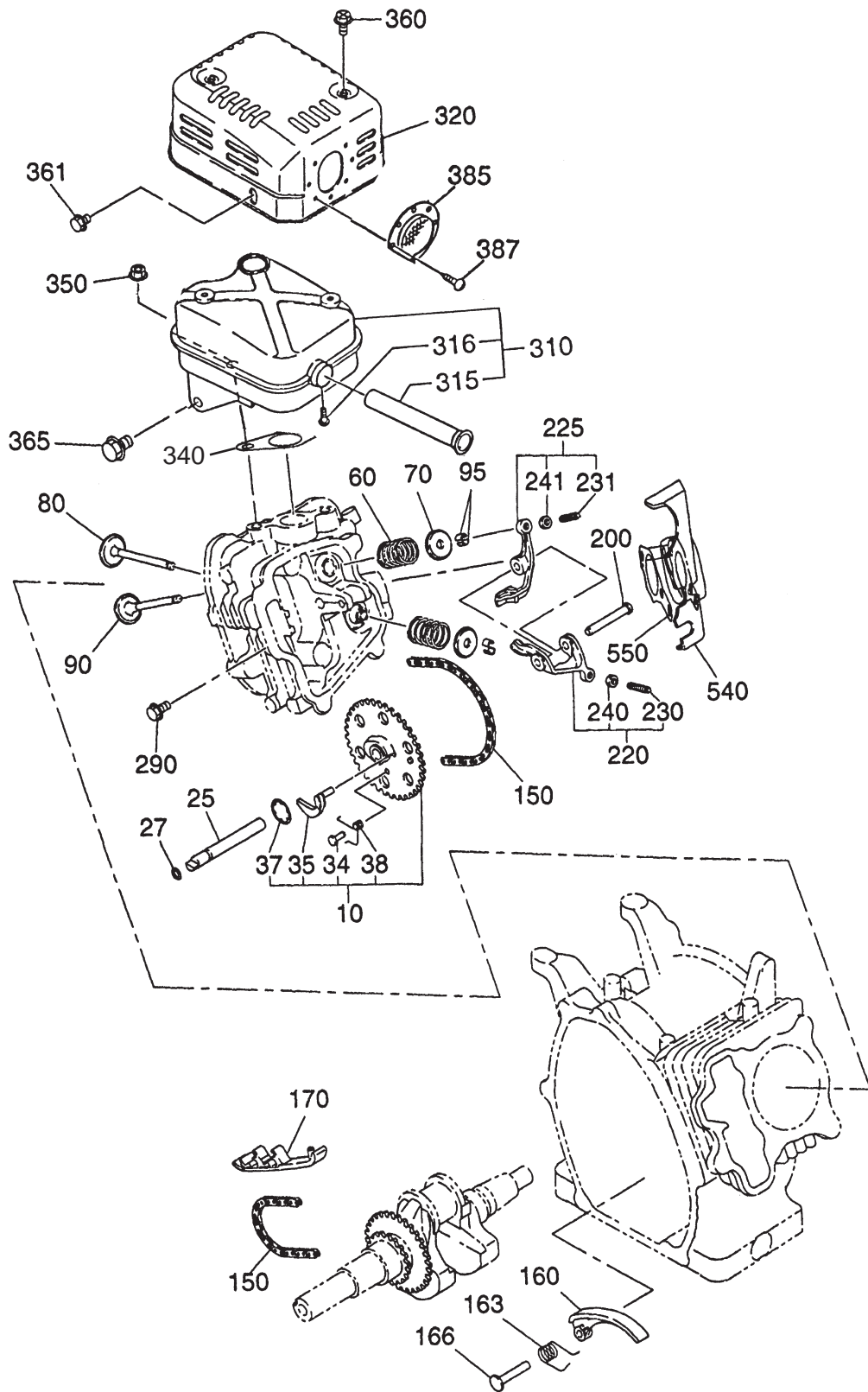

## SECTION 4 INTAKE and EXHAUST GROUP

REF.	PART NO.	DESCRIPTION	QTY.	REMARKS	FROM-TO	FIG.
10	277-31601-01	CAMSHAFT CP	1			400
25	277-35101-03	PIN, camshaft	1			400
27	024-00600-10	O RING	1			400
34	277-38601-03	PIN, spring	1			400
35	277-36401-03	RELEASE LEVER	1			400
37	277-36501-03	CLIP	1			400
38	277-38701-03	RETURN SPRING	1			400
60	279-33601-03	VALVE SPRING	2			400
70	269-33701-03	RETAINER	2			400
80	276-33401-33	INTAKE VALVE	1			400
90	276-33501-33	EXHAUST VALVE	1			400
95	132-10KA0-31	COLLET VALVE	4			400
150	276-35601-01	TIMING CHAIN CP	1			400
160	277-36911-03	TENTIONER	1			400
163	277-37101-03	SPRING, tentioner	1			400
166	277-36902-03	PIN, tentioner	1			400
170	277-36913-13	CHAIN GUIDE	1			400
200	277-35001-23	PIN, rocker	1		5692~	400
	277-35001-13	PIN, rocker	1		5661~5691	400
	277-35001-03	PIN, rocker	1		~5660	400
220	277-36101-00	ROCKER ARM AY, in	1			400
225	277-36102-00	ROCKER ARM AY, ex	1			400
230	014-90500-10	ADJUST SCREW	1			400
231	014-90500-10	ADJUST SCREW	1			400
240	017-00500-20	NUT	1			400
241	017-00500-20	NUT	1			400
290	011-00600-20	FLANGE BOLT	1			400
310	276-30111-01	MUFFLER CP	1			400
315	277-37601-01	SPARK ARRESTOR	1			400
316	015-00400-60	TAPPING SCREW	1			400
320	276-34201-01	MUFFLER COVER CP	1		5753~	400
	277-34201-01	MUFFLER COVER CP	1		~5752	400
340	277-35201-03	GASKET, muffler	1			400
350	980-20082-80	FLANGE NUT	2			400
360	015-20600-90	TAPPING BOLT	2			400
361	011-00600-10	FLANGE BOLT	1			400
365	011-00801-50	FLANGE BOLT	1			400
385	277-37203-01	SCREEN CP	1			400
387	015-00400-60	TAPPING SCREW	2			400
540	277-32902-H3	INSULATOR	1			400
550	277-32903-H3	GASKET, insulator	1			400
570	002-38060-00	FLANGE NUT	2			400
580	011-00600-50	FLANGE BOLT	1			400
850	085-10800-00	RUBBER PIPE	1			400

SECTION 4 INTAKE and EXHAUST GROUP

FIG. 410

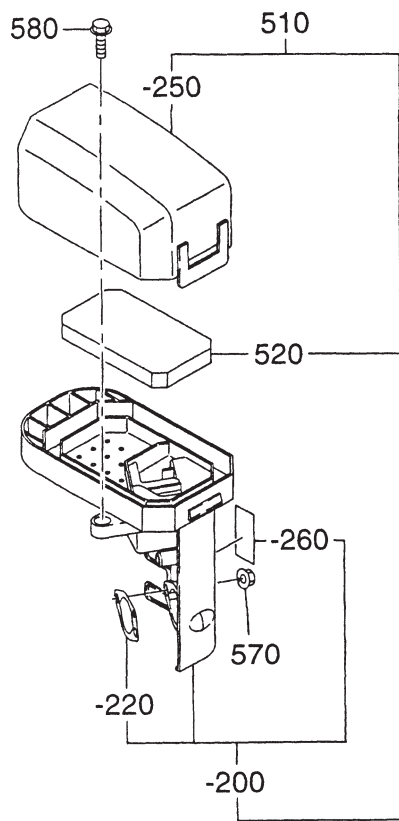



SECTION 5 GOVERNOR GROUP

FIG. 500

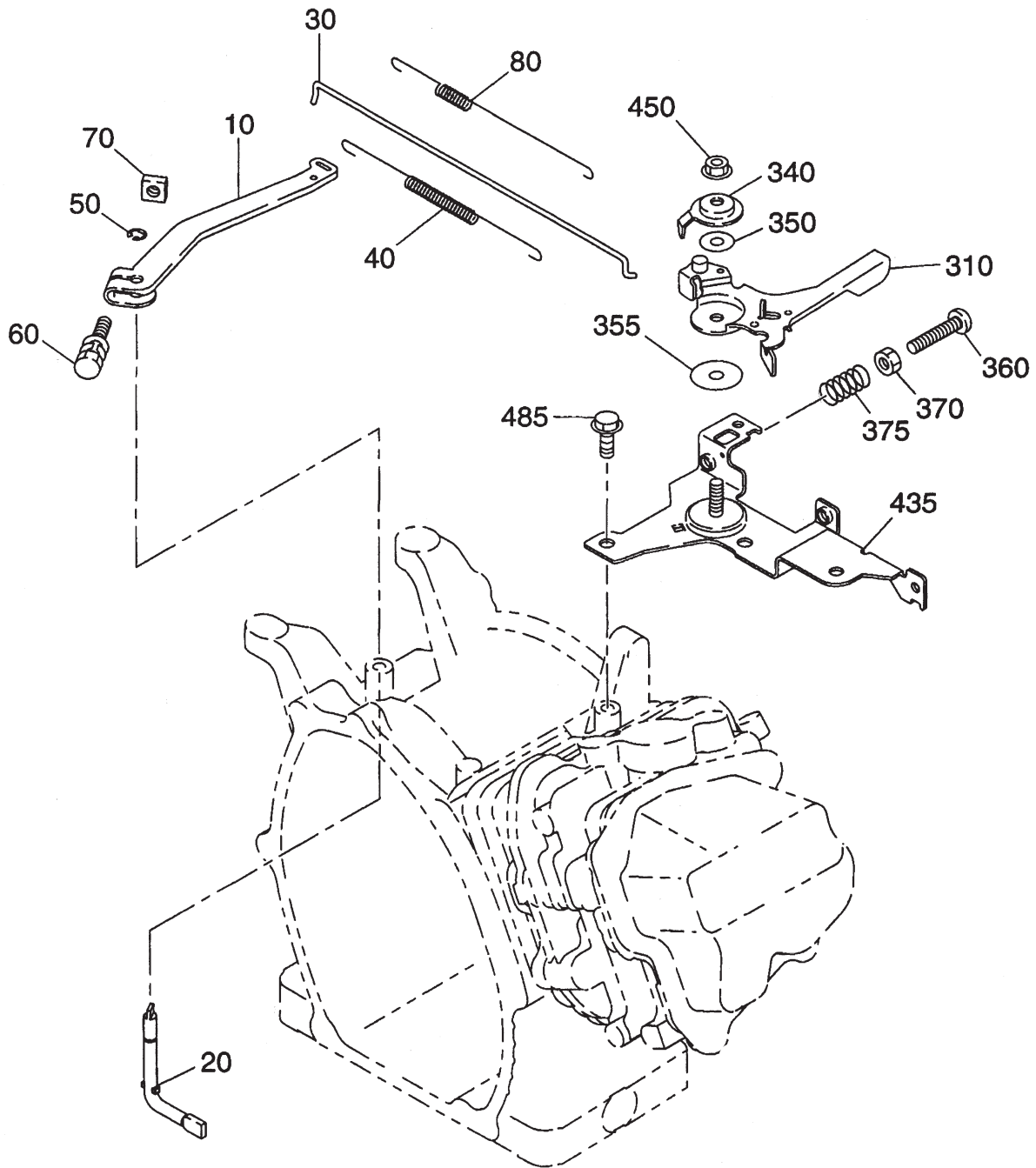





SECTION 6 COOLING and STARTING GROUP

FIG. 600

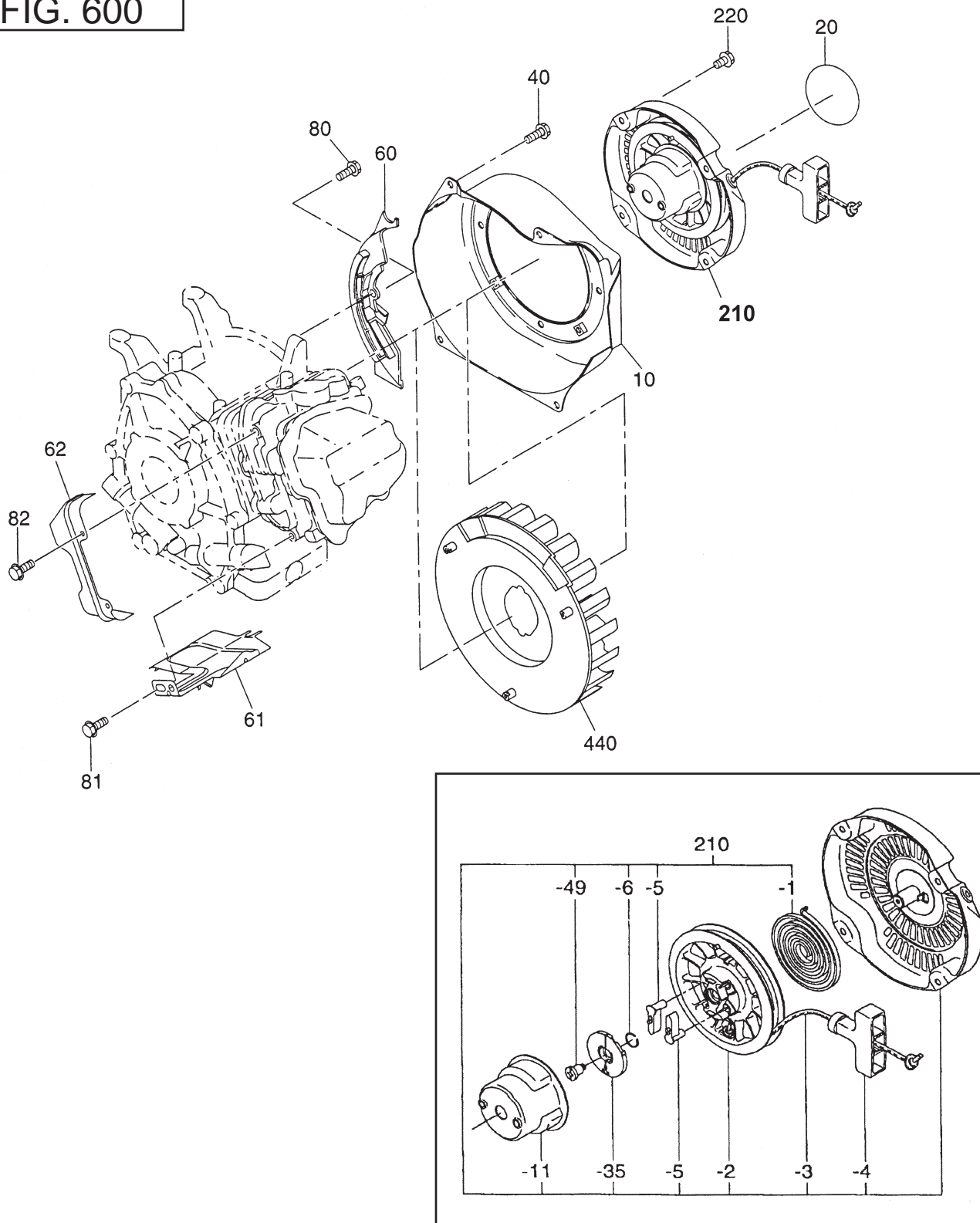



SECTION 7 FUEL, LUBRICATION GROUP

FIG. 700

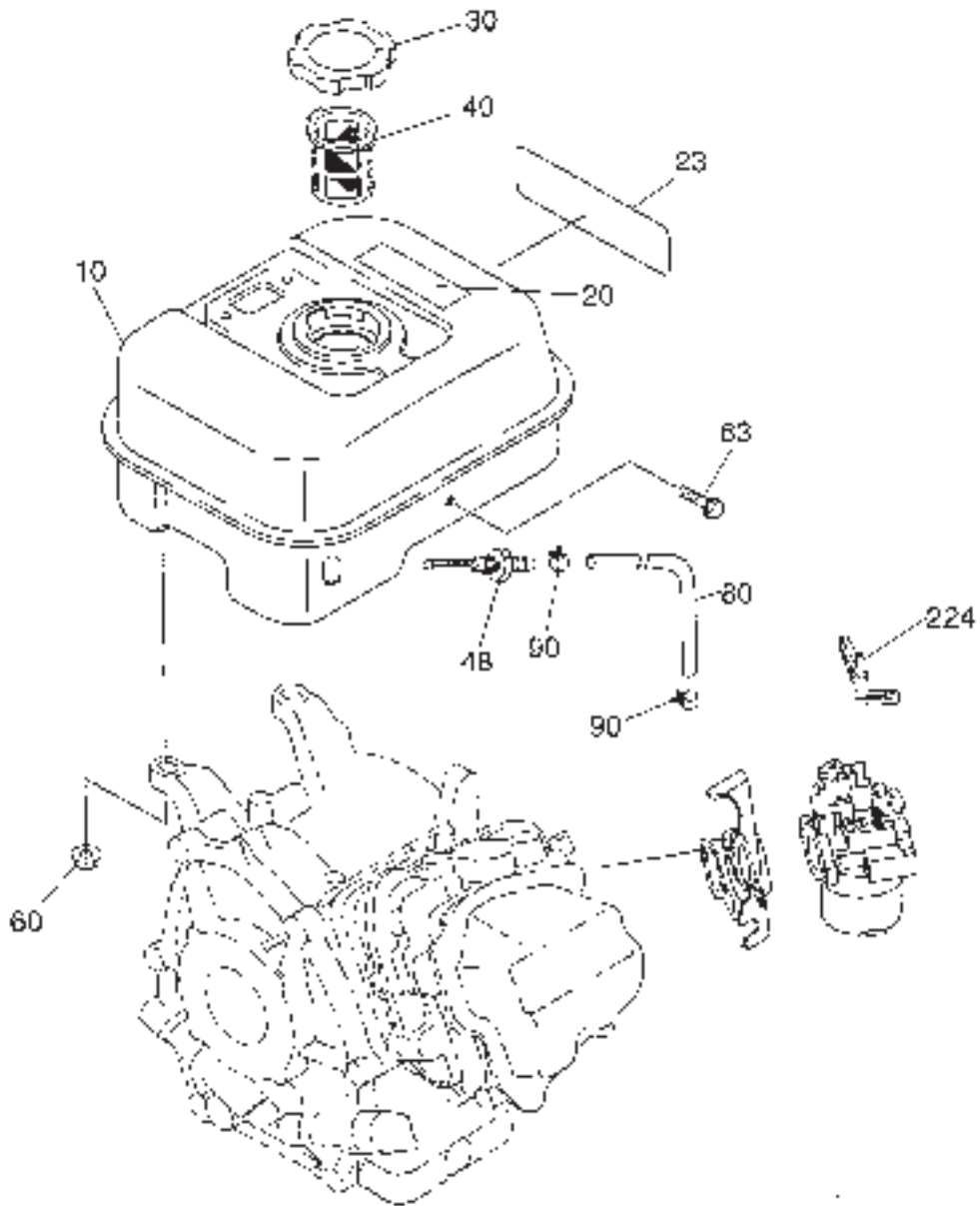



SECTION 7 FUEL, LUBRICATION GROUP

FIG. 710

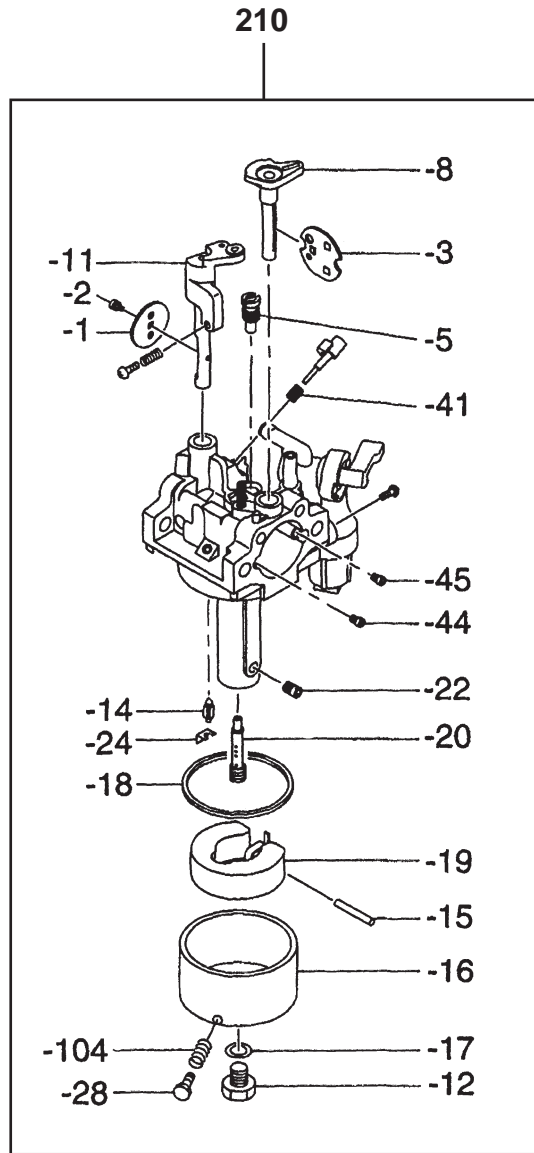



SECTION 8 ELECTRIC DEVICE GROUP

FIG. 800

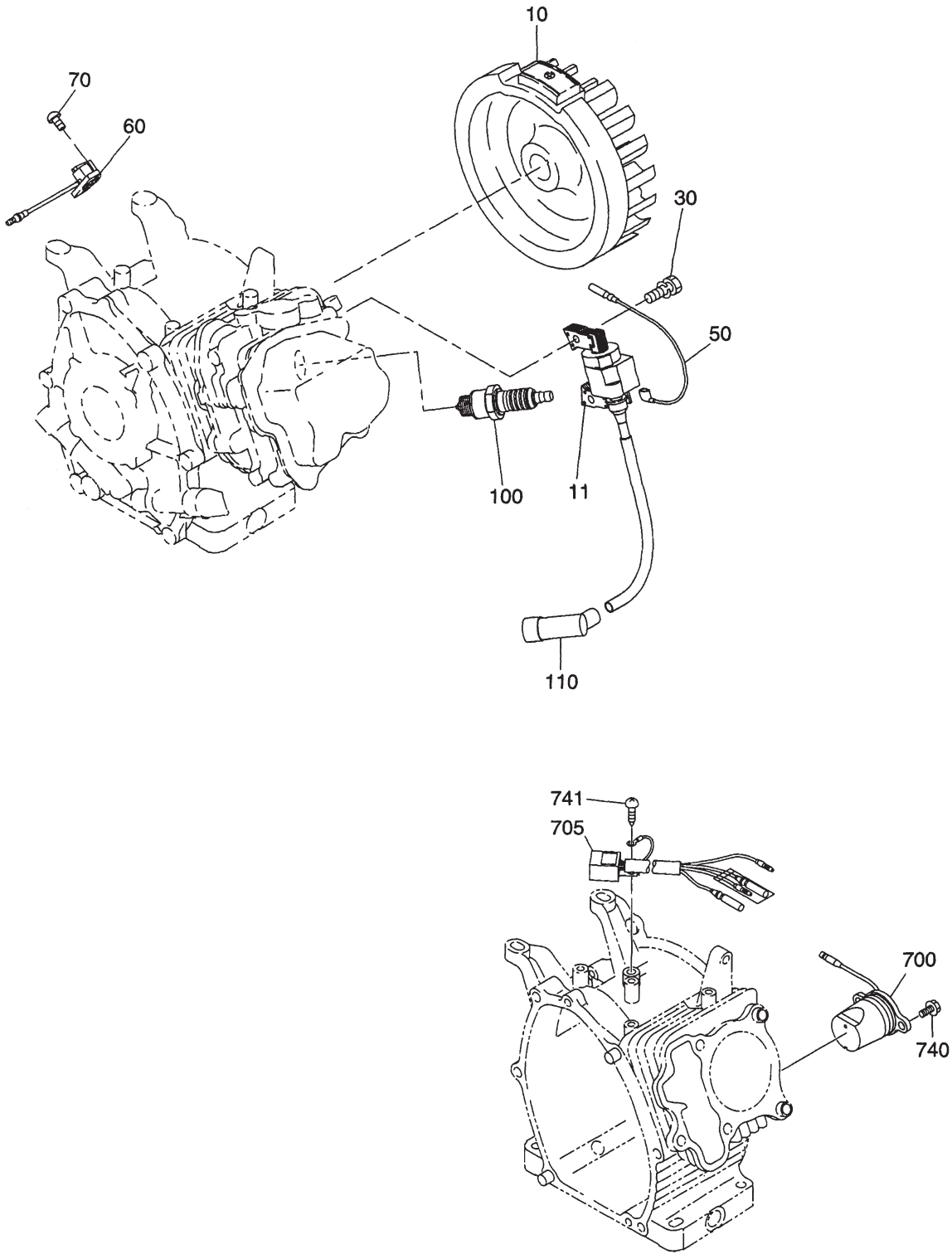





SECTION 9 ACCESSORY GROUP

FIG. 900

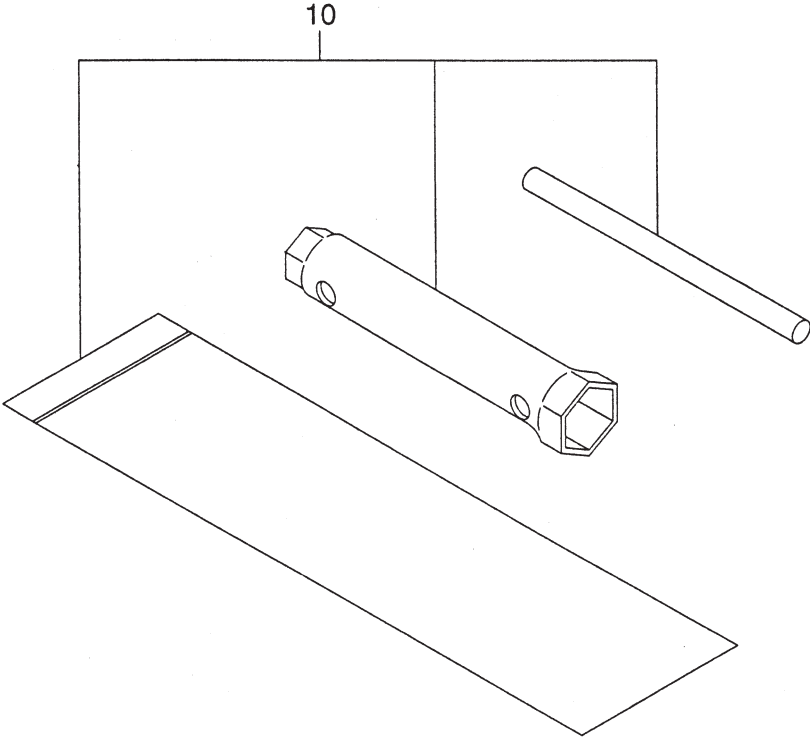



PRINTED IN THE USA