

Digi ConnectTM Wi-Wave Hardware Reference



Part number/version: 90000797_A
Release date: March 2008
www.digiembedded.com

©2008 Digi International Inc.

Printed in the United States of America. All rights reserved.

Digi, Digi International, the Digi logo, a Digi International Company, Jump Start Kit, ConnectCore, NET+, NET+OS and NET+Works are trademarks or registered trademarks of Digi International, Inc. in the United States and other countries worldwide. All other trademarks are the property of their respective owners.

Information in this document is subject to change without notice and does not represent a commitment on the part of Digi International.

Digi provides this document “as is,” without warranty of any kind, either expressed or implied, including, but not limited to, the implied warranties of fitness or merchantability for a particular purpose. Digi may make improvements and/or changes in this manual or in the product(s) and/or the program(s) described in this manual at any time.

This product could include technical inaccuracies or typographical errors. Changes are made periodically to the information herein; these changes may be incorporated in new editions of the publication.

Digi International, Inc.
11001 Bren Road East
Minnetonka, MN 55343 U.S.A.
United States: +1 877 912-3444
Other locations: +1 952 912-3444

www.digiembedded.com

Contents

Chapter 1: About the Module	9
Features.....	9
What's on the module?	10
Digi Connect Wi-Wave module edge connector.....	10
Digi Connect Wi-Wave module edge connector: Pinout.....	11
U.FL connectors.....	11
USB peripheral controller	12
802.11b/g modes and channels	12
Channel allocations	12
Receiver Sensitivity and Transmit Output Power.....	13
Voltage regulators.....	13
Voltage monitor – Reset generator	13
LEDS	13
Power.....	14
DISABLE signal.....	14
Chapter 2: About the Development Board	15
What's on the development board	15
Features.....	15
The development board	16
Unpopulated components	16
Digi Connect Wi-Wave module connector, J52	17
LEDS	19
LED DS1	19
LED DS2	19
Debug (signal) breakout header LEDs	19
Switches and reset functionality.....	20
Voltage monitor.....	20
Alternative methods to trigger RESET#	20
Power supply	21
Input power jack, J3.....	21
Input power supply	21
JTAG Breakout Header, P20	22
JTAG breakout header signal map	22
USB peripheral interface, J4.....	23

USB peripheral jack, J4.....	23
Debug breakout header, P21	24
Debug breakout header signal map	24
W_DISABLE# signal.....	24
U.FL and RP-SMA connectors	25
U.FL connectors.....	25
U.FL cables	25
RP-SMA connectors	26
For more information	26
Chapter 3: Using the Antenna	27
Necessary Conditions for Integration	27
Connect Wi-Wave antenna configurations	28
General information.....	29
Antenna switch.....	29
Antenna specifications: 2 dBi Dipole	29
Attributes	29
Dimensions.....	29
Antenna strength (radiation pattern) diagram	31
Antenna specifications: 5.5 dBi Dipole.....	32
Attributes	32
Dimensions.....	32
Radiation pattern: H-Plane (2.0 and 5.0 GHz)	33
Radiation pattern: E-plane (2.0 and 5.0 GHz)	34
End User Manual: RF Exposure Statements	34
Appendix A: Specifications	35
Environmental specifications	35
Mechanical dimensions	35
Power requirements.....	36
RF exposure statement	36
Safety statements	36
Module and development board dimensions	37
Module dimensions	37
Development board dimensions	38
Appendix B: Certifications	39
FCC Part 15 Class B.....	39

Using this Guide

This guide provides information about the Digi Connect Wi-Wave embedded core module.

Conventions used in this guide

This table describes the typographic conventions used in this guide:

This convention	Is used for
<i>italic type</i>	Emphasis, new terms, variables, and document titles.
monospaced type	Filenames, pathnames, and code examples.

Digi information

Related documentation

For additional documentation, see the Documentation folder in the Start menu.

Documentation updates

Digi occasionally provides documentation updates on the Web site (www.digiembedded.com/support).

Be aware that if you see differences between the documentation you received in your package and the documentation on the Web site, the Web site content is the latest version.

Contact information

For more information about your Digi products, or for customer service and technical support, contact Digi International.

To contact Digi International by	Use
Mail	Digi International, Inc. 11001 Bren Road East Minnetonka, MN 55343 U.S.A
World Wide Web	www.digiembedded.com
Eservice Support	www.digi.com/support/eservice/login.jsp
Telephone (U.S.)	(952) 912-3444 or (877) 912-3444
Telephone (other locations)	+1 (952) 912-3444 or +1 (877) 912-3444

Chapter 1: About the Module

The Digi Connect Wi-Wave module is an 802.11b/g WLAN communications module for use in embedded applications. The module is a single circuit card packaged in a PCI Express Mini Card form factor, and supports all the RF, analog, and digital circuitry necessary to implement WLAN functionality. Using Digi's baseband processor technology, this module is the ideal choice for embedded applications requiring long-term product availability in conjunction with reliability and easy design integration.

The primary interface to the module is through a standards-compliant PCI Express Mini Card edge connector, using a USB 2.0 full speed/high speed link for communication with the host system.

Note: The Digi Connect Wi-Wave edge connector pinout is compliant with the PCI Express Mini Card Electromechanical Specification, Revision 1.1 (March 28, 2005) with this exception: the Digi Connect Wi-Wave has a 4-wire JTAG programming interface mapped to pins 45, 47, 49, and 51.

The Digi Connect Wi-Wave module also provides a dual diversity antenna option through two on-board U.FL connectors, which allow for cabling to remote 2.4 GHz antennas.

Features

- Ultra-compact and standards-based form factor
- Easy design integration through USB 2.0 full speed/high speed interface
- Dual diversity antenna option through two on-module U.FL antenna connectors
- Digi 802.11b/g baseband processor technology for long-term product availability
- -30°C to +60°C operating temperature for harsh environments
- RoHS compliant design

What's on the module?

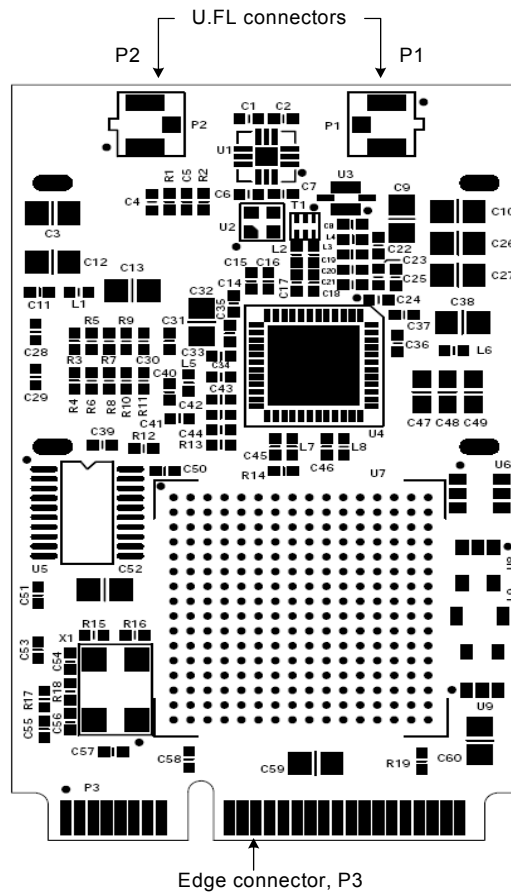

Digi Connect Wi-Wave module edge connector

The Digi Connect Wi-Wave module edge connector is a 52-pin connector whose pinout follows the standard PCI Express Mini Card edge connector pinout as stated in the PCI Express Mini Card Electromechanical Specification, Revision 1.1, with this exception: JTAG signals are mapped onto pins 45, 47, 49, and 51. These signals are reserved and not intended for user applications.

Digi Connect Wi-Wave module edge connector: Pinout

The module edge connector is configured as shown (signal direction w.r.t Wi-Wave):

Pin	Type	WLAN Mini Card signal	Pin	Type	WLAN Mini Card signal
1	n/a	No connect	2	In	Vcc_3.3
3	n/a	No connect	4	In	GND
5	n/a	No connect	6	n/a	No connect
7	n/a	No connect	8	n/a	No connect
9	In	GND	10	n/a	No connect
11	n/a	No connect	12	n/a	No connect
13	n/a	No connect	14	n/a	No connect
15	In	GND	16	n/a	No connect
		Key			Key
17	n/a	No connect	18	In	GND
19	n/a	No connect	20	In	W_DISABLE#
21	In	GND	22	In	RESET (PERST#)
23	n/a	No connect	24	n/a	No connect
25	n/a	No connect	26	In	GND
27	In	GND	28	n/a	No connect
29	In	GND	30	n/a	No connect
31	n/a	No connect	32	n/a	No connect
33	n/a	No connect	34	In	GND
35	In	GND	36	I/O	USB_D-
37	n/a	No connect	38	I/O	USB_D+
39	n/a	No connect	40	In	GND
41	n/a	No connect	42	Out	LED_WWAN#
43	n/a	No connect	44	Out	LED_WLAN#
45	<i>Rsvd (In)</i>	JTAG_TCK	46	Out	LED_WPAN#
47	<i>Rsvd (In)</i>	JTAG_TMS	48	n/a	No connect
49	<i>Rsvd (Out)</i>	JTAG_TDO	50	In	GND
51	<i>Rsvd (In)</i>	JTAG_TDI	52	In	Vcc_3.3

U.FL connectors

The module uses two U.FL antenna connectors (P1 and P2) to allow for cabling to embedded antennas or external antenna connectors. For more information, see Chapter 3, “Using the Antenna.”

USB peripheral controller

The module uses a peripheral USB controller to interface to either a full speed or high speed USB 2.0 link. The link first tries to communicate to the host system board at the high speed USB rate (480 Mbps). If not successful, the link reverts to the full speed USB rate (12 Mbps). This link is used for all communication between the module and the host system board.

Note: The Digi Connect Wi-Wave module does not support low-speed USB connections.

802.11b/g modes and channels

The Digi Connect Wi-Wave transmits and receives data at up to 11 Mbps when operating in 802.11b mode and up to 54 Mbps when operating in 802.11g mode. It supports these 802.11b/g channels:

- Channels 1 through 11 for North America (2.401 GHz-2.473 GHz)
- Channels 1 through 13 for Europe (2.401 GHz-2.483 GHz)
- Channels 1 through 14 for Asia (2.401 GHz-2.495 GHz)

Channel allocations

Channel	Center frequency (MHz)	Frequency spread (MHz - MHz)
1	2412	2401 - 2423
2	2417	2406 - 2428
3	2422	2411 - 2433
4	2427	2416 - 2438
5	2432	2421 - 2443
6	2437	2426 - 2448
7	2442	2431 - 2453
8	2447	2436 - 2458
9	2452	2441 - 2463
10	2457	2446 - 2468
11	2462	2451 - 2473
12	2467	2456 - 2478
13	2472	2461 - 2483
14	2484	2473 - 2495

Receiver Sensitivity and Transmit Output Power	-71 dBm @ 54 Mbps
	-81 dBm @ 11 Mbps
	-88 dBm @ 6 Mbps
	-93 dBm @ 1 Mbps
	13.8 dBm OFDM
	17 dBm PSK/CCK

Voltage regulators

The module takes in $3.3V \pm 9\%$ (3.00V to 3.60V) as its main input power. This power is filtered and used as a 3.3V supply to portions of the digital logic. This power also acts as input to dedicated on-board voltage regulators.

Voltage monitor – Reset generator

The module does not provide a voltage monitor or automatic reset signal generator; rather, the module uses a reset signal generated by the host system board.

LEDS

The module does not have any on-board LEDs, but it drives the LED_WLAN# signal (pin 44) to indicate WLAN association and transmit/receive activity. This table shows the different LED states:

LED state	Indication
Off	Not powered on
On	Associated and authenticated
Slow blink	Not associated or authenticated
Intermittent blink	Transmit/receive activity

Power

The module requires only +3.3 VDC, 750 mA max. This power must be a well-regulated +3.3V supply due to limited supply filtering in the module. The digital inputs and outputs are 3.3V CMOS compatible. See “Power requirements” on page 36 for specifications.

DISABLE signal

The module supports the active low `w_DISABLE#` signal (pin 20) as specified in the PCI Express Mini Card Electromechanical Specification. This signal not only disables the power supplies to the radio portion of the module, it also powers down additional portions of the module to reduce power consumption to a minimum.

Chapter 2: About the Development Board

The development board is designed for product evaluation and development purposes. In addition to the Digi Connect Wi-Wave connector, the development board provides several breakout connectors and interfaces.

What's on the development board

Features

- Digi Connect Wi-Wave connector
- Pushbutton reset switch and under voltage reset logic
- External USB Type B connector USB peripheral interface
- Additional signal headers for user access
- Two U.FL RP-SMA antenna connectors
- -30°C to +75°C ambient operating temperature
- RoHS compliant design

ABOUT THE DEVELOPMENT BOARD

What's on the development board

The development board

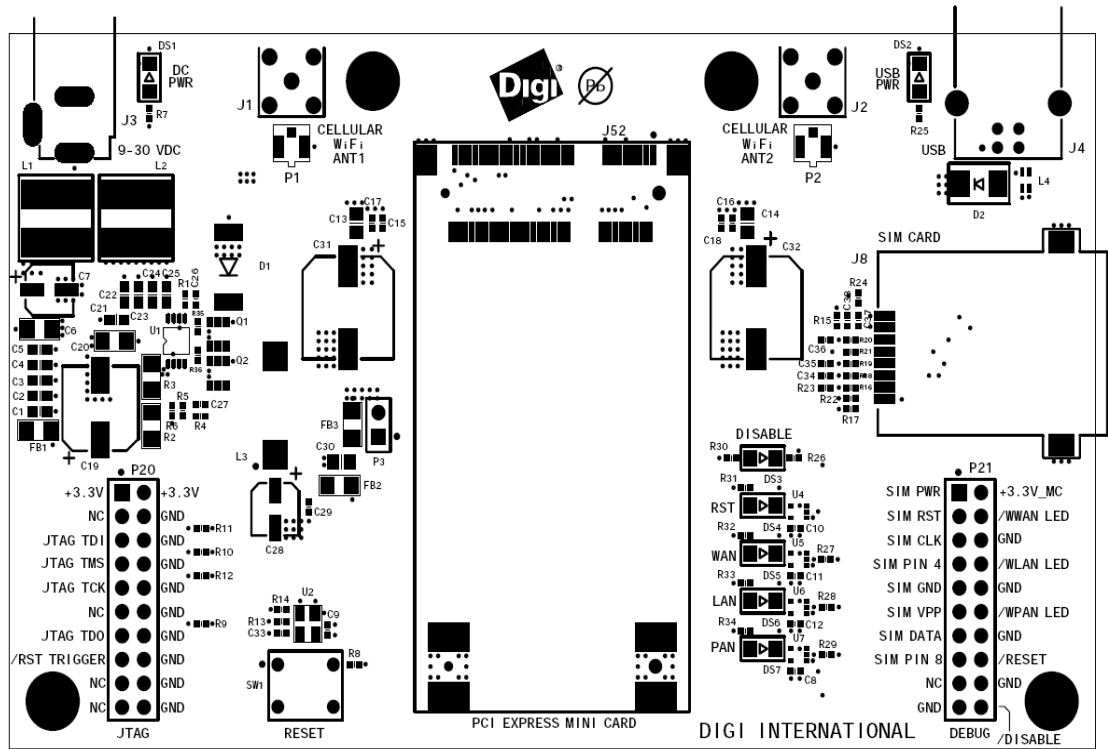

Unpopulated components

There are components on the development board that are currently not populated. These components allow the development board to be used in other applications.

Digi Connect Wi-Wave module connector, J52

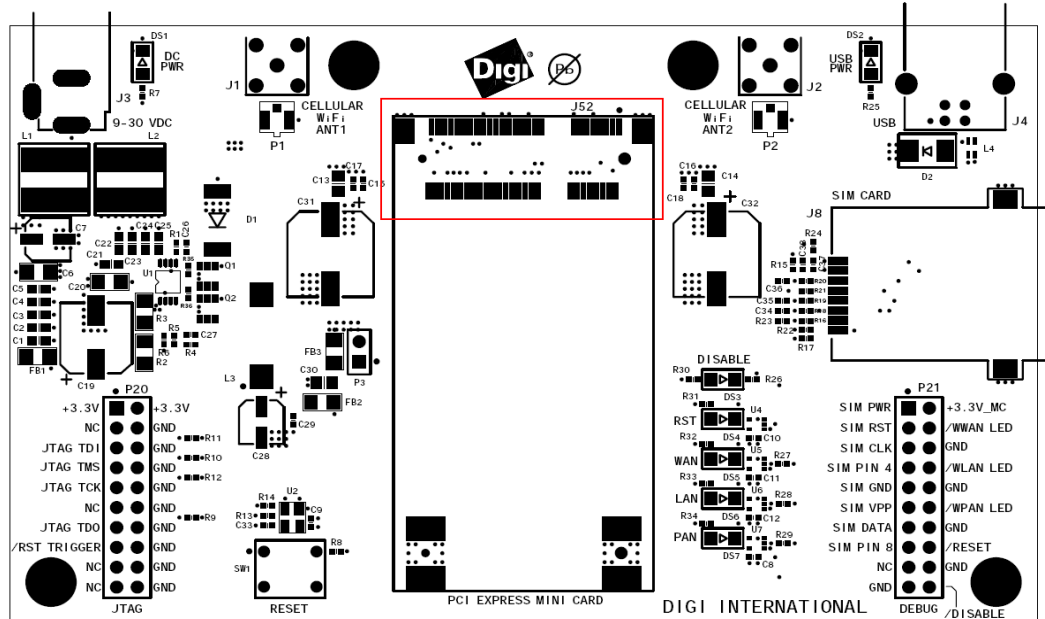

Place the Digi Connect Wi-Wave module into the connector and support bracket, J52, on the development board.

The Digi Connect Wi-Wave module connector is a 52-pin connector that conforms to the PCI Express Mini Card Electromechanical Specification, Rev. 1.1, with additional non-standard connections (to the reserved pins on the standard connector).

ABOUT THE DEVELOPMENT BOARD*Digi Connect Wi-Wave module connector, J52***Note:** Signal direction w.r.t PCIe Mini Card.

Pin	Type	Signal	Pin	Type	Signal
1	n/a	No connect	2	In	Vcc_3.3
3	n/a	No connect	4	In	GND
5	n/a	No connect	6	n/a	No connect
7	n/a	No connect	8	Out	UIM_PWR (C1)
9	In	GND	10	I/O	UIM_DATA (C7)
11	n/a	No connect	12	Out	UIM_CLK (C3)
13	n/a	No connect	14	Out	UIM_RESET (C2)
15	In	GND	16	Out	UIM_Vpp (C6)
Key	Key	Key	Key	Key	Key
17	I/O	UIM C8	18	In	GND
19	I/O	UIM C4	20	In	W_DISABLE#
21	In	GND	22	In	RESET (PERST#)
23	n/a	No connect	24	n/a	No connect
25	n/a	No connect	26	In	GND
27	In	GND	28	n/a	No connect
29	In	GND	30	n/a	No connect
31	n/a	No connect	32	n/a	No connect
33	n/a	No connect	34	In	GND
35	In	GND	36	I/O	USB_D-
37	n/a	No connect	38	I/O	USB_D+
39	n/a	No connect	40	In	GND
41	n/a	No connect	42	Out	LED_WWAN#
43	n/a	No connect	44	Out	LED_WLAN#
45	n/a or In	No connect or JTAG_TCK	46	Out	LED_WPAN#
47	n/a or In	No connect or JTAG_TMS	48	n/a	No connect
49	n/a or Out	No connect or JTAG_TDO	50	In	GND
51	n/a or In	No connect or JTAG_TDI	52	In	Vcc_3.3

LEDs

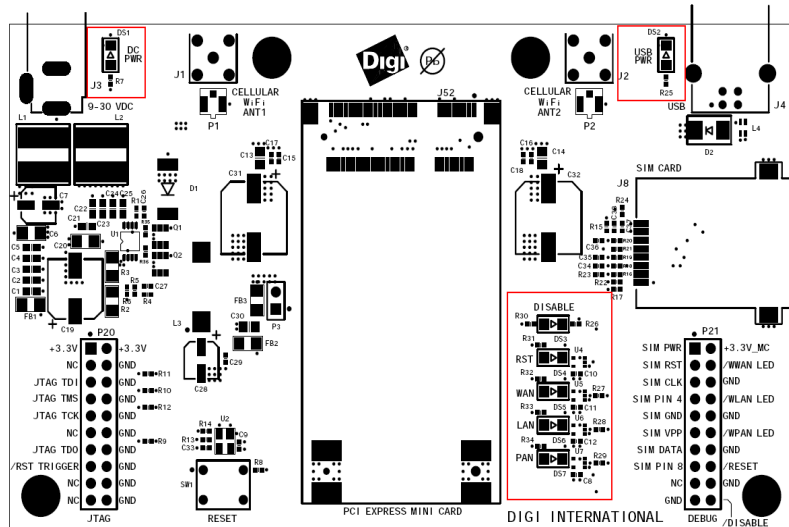

LEDs: DS3-DS7

LED DS1

The switching regulator is adjusted to output $+3.3V_{DC} \pm 5\%$ or better. LED DS1 lights up when the regulator outputs $+3.3V$ power. See “Power supply” on page 21 for more information.

LED DS2

LED DS2 lights up when the host system supplies power over the USB bus. This LED indicates that the host platform has recognized the attachment of a USB peripheral device on the USB bus. See “USB peripheral interface, J4” on page 23 for more information.

Debug (signal) breakout header LEDs

Five LEDs are associated with the debug breakout header (J4):

- **DISABLE, DS3:** Lights up when the W_DISABLE# signal is asserted.
- **RST, DS4:** Lights up when the RESET# signal is asserted.
- **WAN, DS5:** Reserved for future use.
- **LAN, DS6:** Lights up when the module drives the LED_WLAN# signal.
- **PAN, DS7:** Reserved for future use.

See “Debug breakout header, P21” on page 24 for more information.

Switches and reset functionality

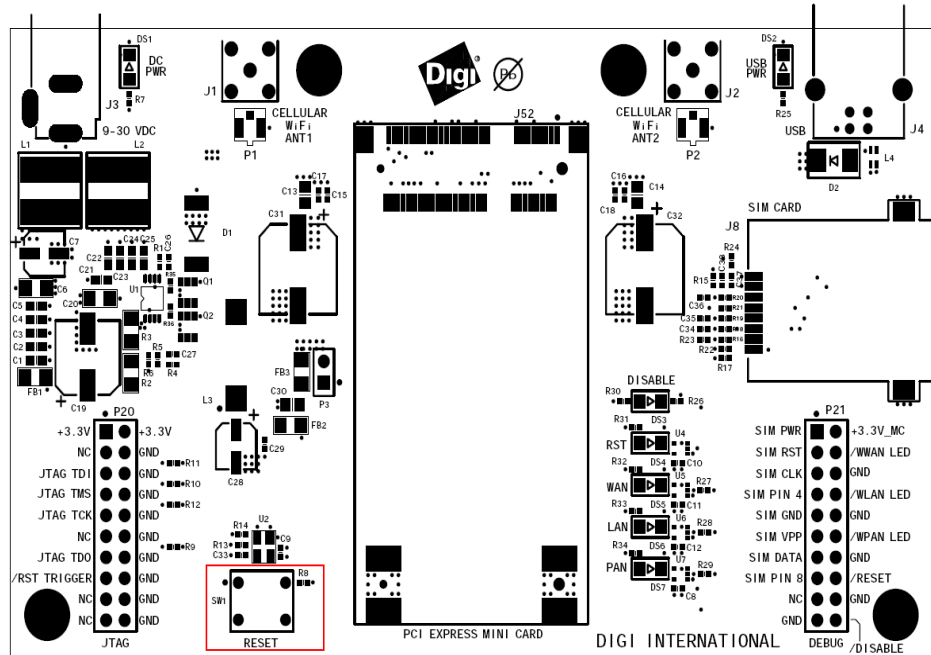

Voltage monitor

The development board provides a power supply voltage monitor and reset generator. When the +3.3V regulated supply voltage drops below 2.93V, the reset signal – RESET# – is asserted for a minimum of 140 msec. This signal is connected to the Digi Connect Wi-Wave edge connector (pin 22), as well as to the debug breakout header for monitoring.

Alternative methods to trigger RESET#

In addition to supply voltage monitoring, reset logic can be triggered in two other ways. The RESET# signal is asserted when you do one of these actions:

- Manually push SW1, a pushbutton reset switch on the development board
- Pull low pin 15 on the JTAG breakout header, P20.

Power supply

The development board provides a 3.3V_{DC} switching power supply. Either a bench power supply or an AC wall adapter supplies input power to the development board. The required input voltage range is 9-30V_{DC}.

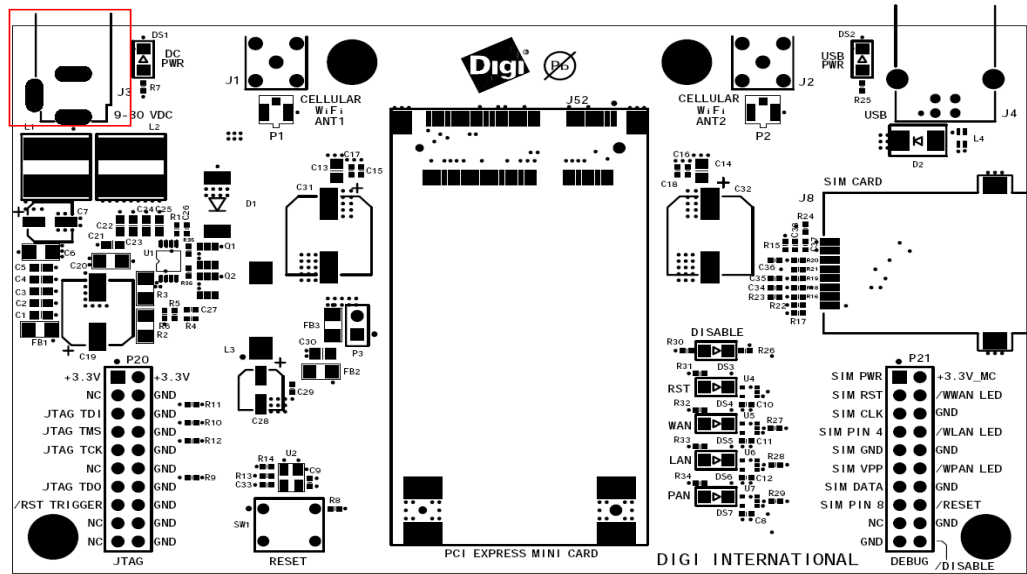

Input power jack, J3

The input power jack, J3, is a barrel connector that accepts 9-30 VDC. The power jack is labeled J3 on the development board. This figure schematically represents the power jack's polarity:

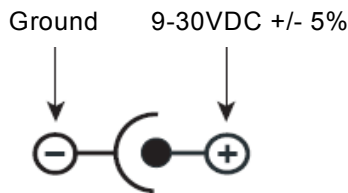

Input power supply

The output current of this regulator is limited to 2.4 amps and the Digi Connect Wi-Wave module draws no more than .750 amps. Using these values as a guideline, and using an 80% efficiency for the switching regulator, the input power supply should be rated to provide at least 3 watts of power.

Important: The development board can use USB power as the power source for the 3.3V regulator. This is accomplished by simply connecting the USB

cable to the development board. However, Digi recommends using the supplied AC wall adapter.

JTAG Breakout Header, P20

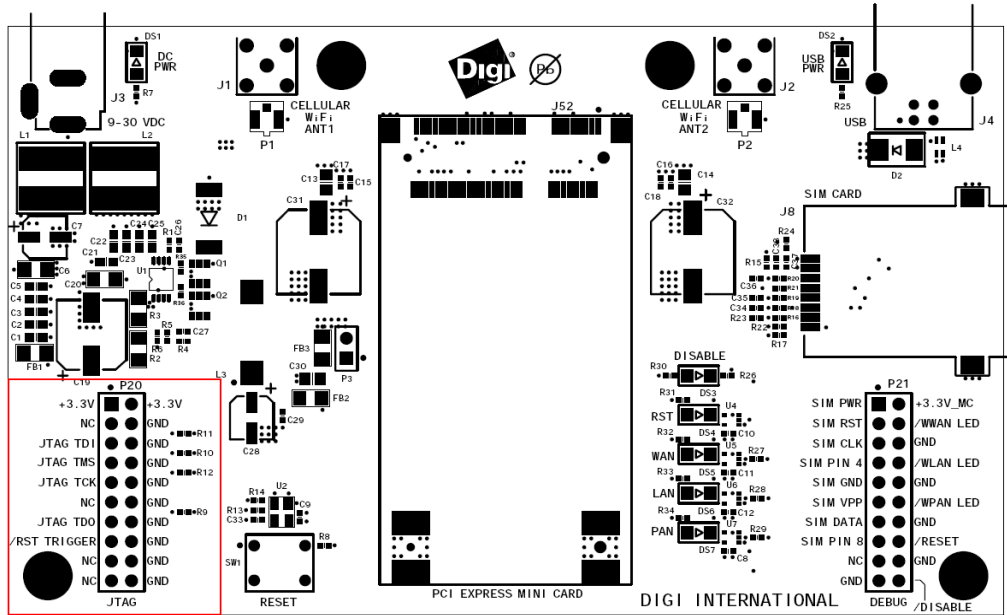

JTAG breakout header signal map

The development board provides a 20-pin JTAG header, P20. The pins are allocated as shown:

Pin	Type	Signal	Pin	Type	Signal
1	Monitor pt	+3.3V	2	Monitor pt	+3.3V
3	n/a	No connect	4	Monitor pt	GND
5	In	JTAG TDI	6	Monitor pt	GND
7	In	JTAG TMS	8	Monitor pt	GND
9	In	JTAG TCK	10	Monitor pt	GND
11	n/a	No connect	12	Monitor pt	GND
13	Out	JTAG TDO	14	Monitor pt	GND
15	In	RST# TRIGGER	16	Monitor pt	GND
17	n/a	No connect	18	Monitor pt	GND
19	n/a	No connect	20	Monitor pt	GND

USB peripheral interface, J4

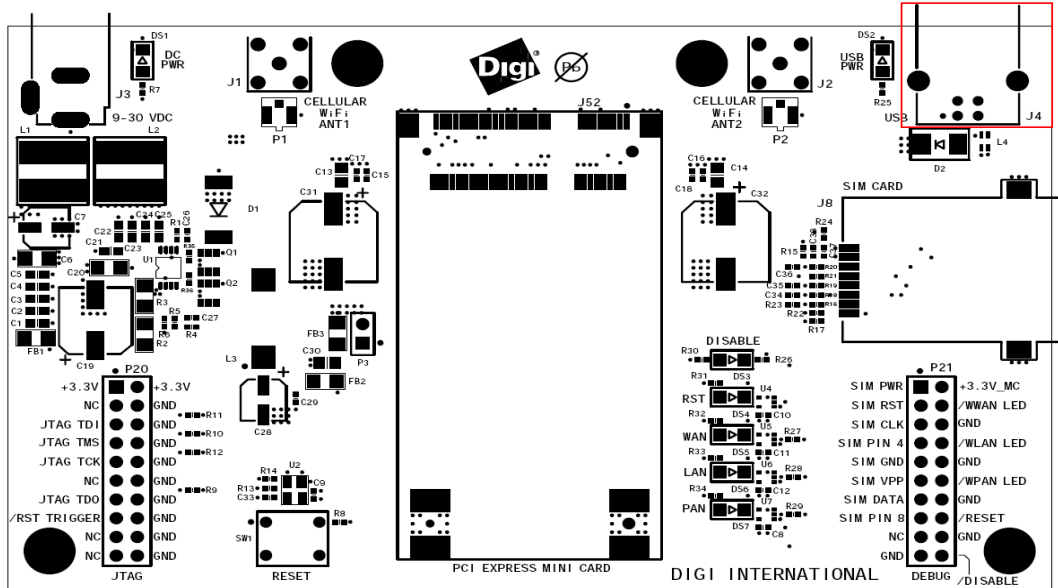

USB peripheral jack, J4

The USB Type B connector, J4, is the primary communications interface to the development board. The USB bus is routed from the USB peripheral jack to the appropriate module connector pins.

Debug breakout header, P21

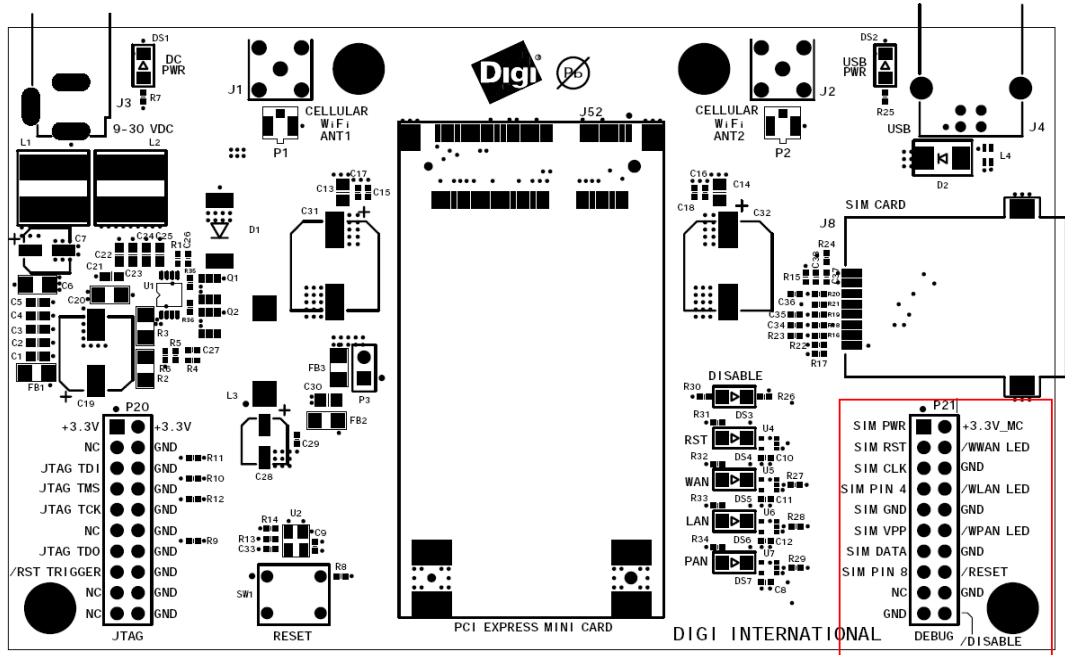

The debug breakout header’s primary purpose is to provide access to the W_DISABLE# signal. The W_DISABLE# signal is typically used as a hardware means to disable RF transmissions from the module without software intervention.

Debug breakout header signal map

Pin	Type	Signal	Pin	Type	Signal
1	Rsvd	SIM_PWR	2	Monitor pt	+3.3V_MC
3	Rsvd	SIM_RST	4	Monitor pt	LED_WWAN#
5	Rsvd	SIM_CLK	6	Monitor pt	GND
7	Rsvd	SIM_Pin 4	8	Monitor pt	LED_WLAN#
9	Rsvd	SIM_GND	10	Monitor pt	GND
11	Rsvd	SIM_VPP	12	Monitor pt	LED_WPAN#
13	Rsvd	SIM_DATA	14	Monitor pt	GND
15	Rsvd	SIM_Pin 8	16	Monitor pt	RESET#
17	n/a	No connect	18	Monitor pt	GND
19	Monitor pt	GND	20	In	W_DISABLE#

W_DISABLE# signal

The active low W_DISABLE# signal is on pin 20 of the debug breakout header. GND signals are positioned adjacent to the W_DISABLE# signal on pins 18 and 19. To

assert the W_DISABLE# signal to the module, place a jumper between either pins 18 and 20 or pins 19 and 20.

As an alternative, you can drive this pin with a low voltage TTL or CMOS driver. When asserted, W_DISABLE# lights the DISABLE LED, DS3.

U.FL and RP-SMA connectors

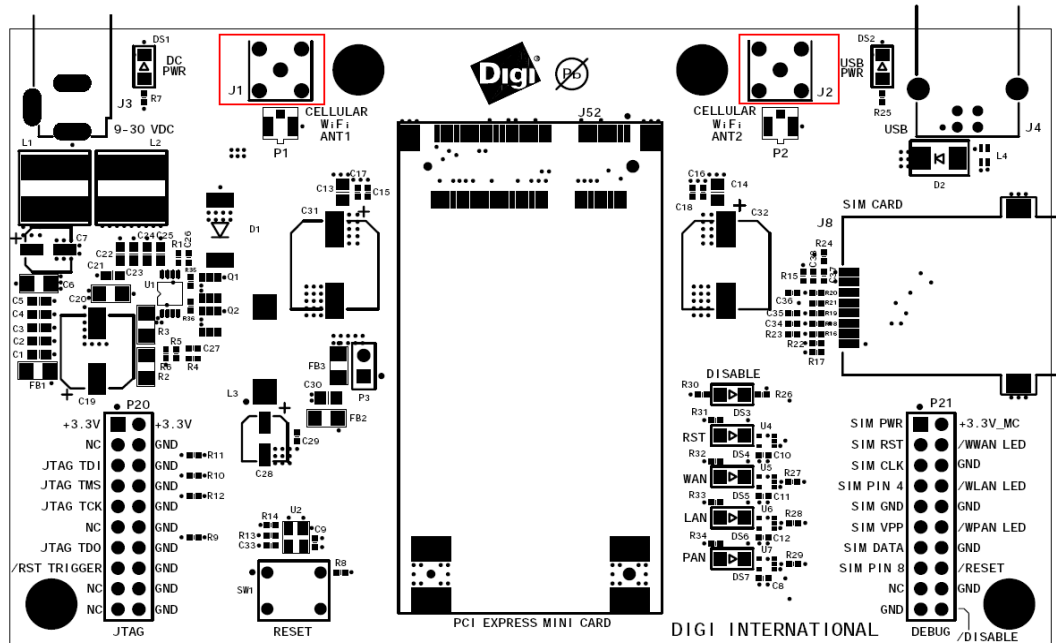

U.FL connectors

The development board has two U.FL connectors that pair with two RP-SMA connectors. U.FL connector P1 pairs with RP-SMA connector J1; U.FL connector P2 pairs with RP-SMA connector J2.

U.FL cables

The development kit includes two U.FL-to-U.FL cables that can be used to connect the module and development board. The number of cables used depends on whether one antenna is used to transmit and receive or two antennas are used (diversity receive).

Single antenna configuration: Connect one end of the U.FL cable to connector P1 on the development board and the other end of the cable to connector P1 on the Digi Connect Wi-Wave module.

Dual antenna configuration: In addition to the connections outlined in the Single antenna configuration, connect one end of the second U.FL cable to connector P2

ABOUT THE DEVELOPMENT BOARD

U.FL and RP-SMA connectors

on the development board and the other end of the cable to connector P2 on the Digi Connect Wi-Wave module.

RP-SMA connectors

RP-SMA Wi-Fi antennas are attached to the two RP-SMA connectors, J1 and J2.

Single antenna configuration: Attach an RP-SMA antenna to RP-SMA connector J1.

Dual antenna configuration: Attach RP-SMA antennas to both RP-SMA connectors J1 and J2.

For more information

For information about the antenna(s), see Chapter 3, “Using the Antenna.”

Chapter 3: Using the Antenna

The Digi Connect Wi-Wave development board supports two types of antennas:

- 29000095 ANT, WHIP 2.4-2.5 GHz Dipole (2.0000)
- 29000146 ANT, WHIP 2.4 GHz Dipole 5 dBi (2.0000)

Attach the U.FL-to-U.FL cables, provided in the development kit, to both the module and the development board. There are two cables included; whether you use one cable or both depends on how you set up your antenna(s).

Be sure that the antenna you use complies with the regulatory requirements of your region. In North America, for example, you can operate only with antennas approved by Digi International, Inc., or antennas matching the specifications of Digi-approved antennas.

Necessary Conditions for Integration

The following conditions are necessary for integration:

- The antenna must be installed such that 20 cm is maintained between the antenna and users for all installations.
- The transmitter module may not be co-located with any other transmitter or antenna.
- The Module is approved using the FCC “unlicensed modular transmitter approval” method; therefore, the module must be used with the originally-approved antennas only.

As long as you meet these three conditions, further transmitter testing will not be required. However, you are still responsible for testing your end-product for any additional compliance requirements associated with this module installation (e.g., digital device emissions, PC peripheral requirements, etc.).

Note: In the event that any of these conditions cannot be met (e.g., portable configurations, co-location with another transmitter, or use of a different antenna), then the FCC authorization is no longer considered valid, and you are unable to use the FCC ID on the final product. In these circumstances, you will be responsible for

re-evaluating the end product (including the transmitter) and obtaining a separate FCC authorization.

**Connect
Wi-Wave antenna
configurations**

The Digi Connect Wi-Wave can transmit data or receive data, but not at the same time.

Note: If only one antenna is used, it must be connected to Wi-Fi RP-SMA antenna connector J1. This is the Digi Connect Wi-Wave's primary antenna.

General information

The module uses the same antennas to transmit and receive the 802.11b/g RF signal. An antenna switch is required to isolate the transmit signal from the receive signal. The antenna switch works by alternately connecting the antennas to either the transceiver transmit output or the transceiver receive input. To support this antenna sharing scheme, the module operates in half-duplex mode; receive and transmit operations do not occur at the same time.

Antenna switch

The antenna switch is a digitally controlled 2.4 GHz, 50 ohm, multi-function solid state switch, controlled by software.

The switch can handle >28dBm of signal on the transmit port. The insertion loss of the antenna switch is <0.5dB and the receive to transmit port isolation is >23dB.

Antenna specifications: 2 dBi Dipole

Attributes

Attribute	Property
Frequency	2.4~2.5 GHz
Power output	2W
DB gain	2 dBi
VSWR	< or = 2.0
Dimension	108.5 mm x 10.0 mm
Weight	10.5g
Temperature rating	-40°~+80° C
Part number	DG-ANT-20DP-BG

Dimensions

Note: Dimensions are provided for reference purposes only. The actual antenna might vary.

USING THE ANTENNA
Antenna specifications: 2 dBi Dipole

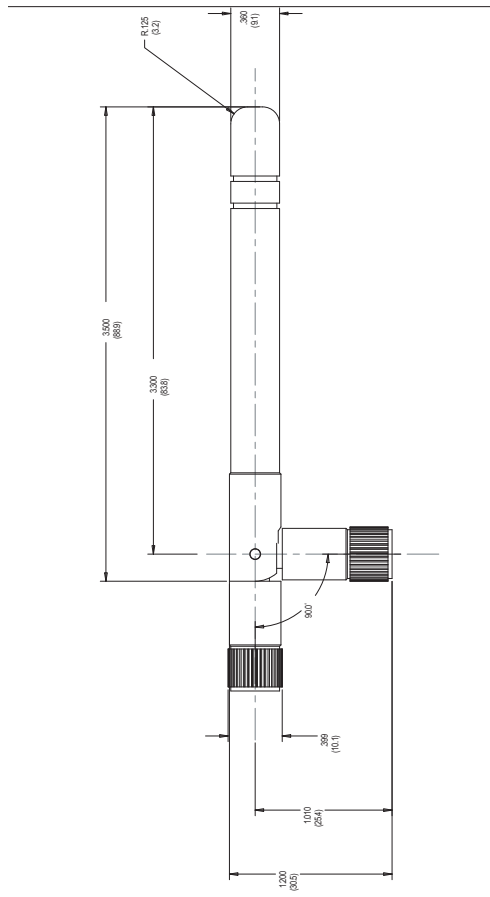

**Antenna strength
(radiation
pattern) diagram**

This diagram shows the strength of the signal received by the whip antenna on both a horizontal and vertical plane. The diagram shows the magnetic field when the antenna is in a vertical position. The red solid line represents the horizontal plane and the green dotted line represents the vertical plane. You can see in the illustration that at 90 degrees, the signal strength is 0 (as expected).

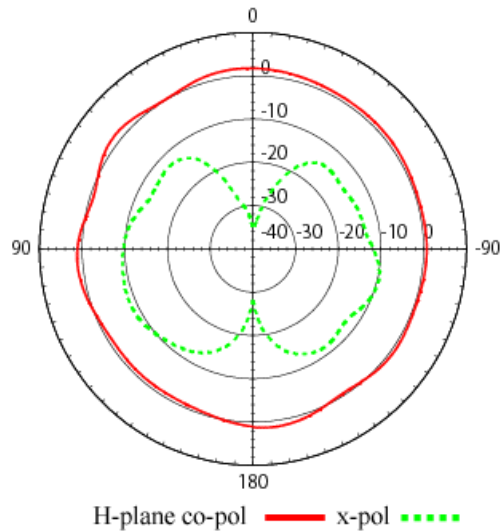

Antenna specifications: 5.5 dBi Dipole

Attributes

Attribute	Band 1	Band 2
Frequency	2.4~2.5 GHz	5.15~5.35 GHz 5.725~5.85 GHz
VSWR	2.0 max	
Return loss	-10 dB max	
DB gain	5 dBi (Typ)	
Polarization	Linear	
Power output	1W	
Dimension	See measurements in the drawing after the table	
Operating temperature	-20°~+65°C	
Storage temperature	-20°~+65°C	
Part number	DG-ANT-55DP-AG	

Dimensions

Note: Dimensions are provided for reference purposes only. The actual antenna might vary.

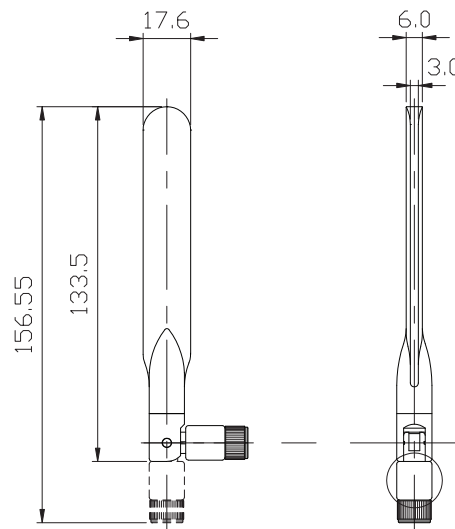

**Radiation
 pattern: H-Plane
 (2.0 and 5.0 GHz)**

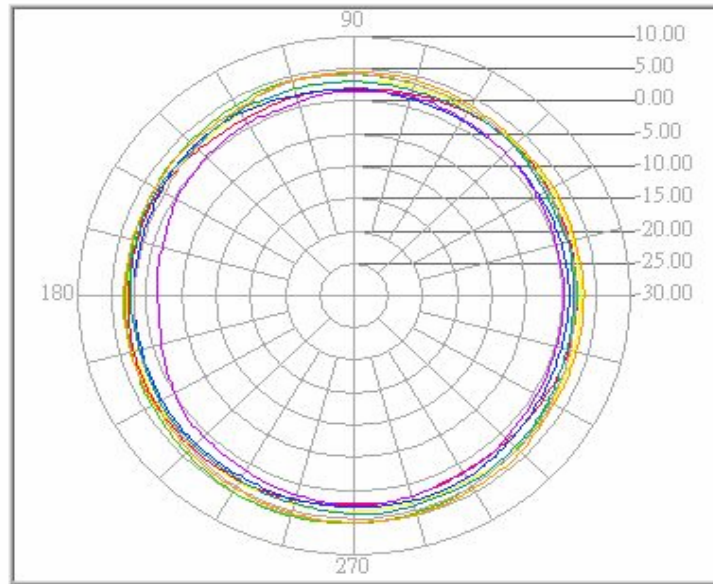

Color	Freq (MHz)	Peak (dBi)	Angle (o)	Avg (dBi)
Yellow	2400.0	3.39	257.68	2.98
Red	2450.00	3.17	214.74	2.37
Blue	2500.00	2.79	288.0	1.96
Purple	5150.00	2.25	280.42	0.82
Green	5200.00	5.23	252.63	2.71
Light brown	5250.00	4.51	272.84	3.16
Orange	5750.00	5.03	267.79	3.88
Aqua	5850.00	3.83	276.63	2.74

**Radiation
 pattern: E-plane
 (2.0 and 5.0 GHz)**

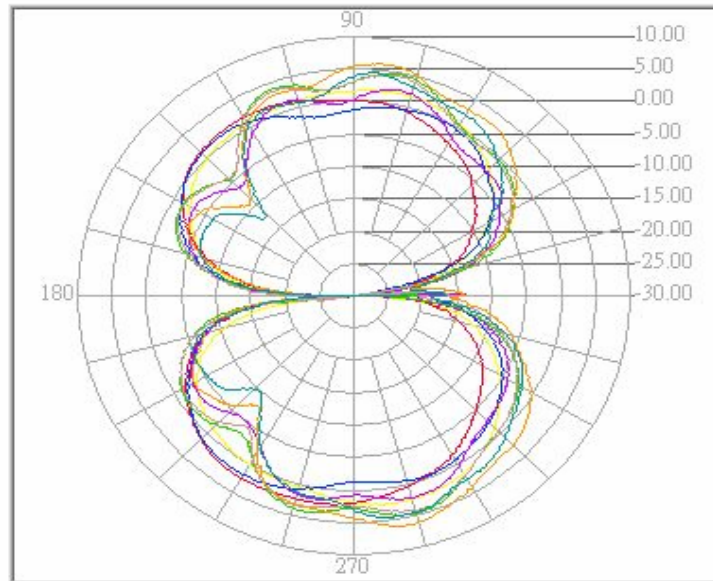

Color	Freq (MHz)	Peak (dBi)	Angle (o)	Avg (dBi)
Yellow	2400.0	2.60	283.22	-1.10
Red	2450.00	2.57	240.42	-1.36
Blue	2500.00	1.92	237.27	-1.78
Purple	5150.00	2.37	78.67	-1.91
Green	5200.00	4.80	79.30	0.32
Light brown	5250.00	4.49	79.93	-0.01
Orange	5750.00	6.34	283.85	1.08
Aqua	5850.00	4.67	283.22	-0.46

End User Manual: RF Exposure Statements

The end user manual must include the following information in a prominent location:

"IMPORTANT NOTE: To comply with FCC RF exposure compliance requirements, the antenna used for this transmitter must be installed to provide a separation distance of at least 20 cm from all persons and must not be co-located or operating in conjunction with any other antenna or transmitter."

Appendix A: Specifications

This appendix provides Digi Connect Wi-Wave module specifications as well as safety statements and antenna specifics.

Environmental specifications

The module board assembly meets all functional requirements when operating in this environment:

- Operating temperature: -30°C to +60°C
- Storage temperature: -40°C to +125°C
- Relative humidity: 5% to 95%, non-condensing
- Altitude: 0 to 12,000 feet

Mechanical dimensions

- Length: 2.006 inches (50.95 mm)
- Width: 1.181 inches (30.00 mm)
- Height: 0.187 inches (4.75 mm)
- Top: 0.095 inches (2.40 mm)
- Bottom: 0.053 inches (1.35 mm)
- Weight: 8 grams (approximately)

Power requirements

Parameter	Limits		
Input voltage (Vcc)	3.3V±9% (3.00V to 3.60V)		
Input current	750mA max		
Input low voltage	0.0V	<V _{IL}	<0.3*Vcc
Input high voltage	0.7*Vcc	<V _{IH}	<Vcc
Output low voltage	0.0V	<V _{OL}	<0.4V
Output high voltage	Vcc-0.4V	<V _{OH}	<Vcc

RF exposure statement

The Digi Connect Wi-Wave module complies with RF exposure limits for humans as called out in RSS-102. It is exempt from RF evaluation based on its operating frequency of 2.4 GHz, and effective radiated power less than the three watt requirement for a mobile device (>20 cm separation) operating at 2.4 GHz.

Safety statements

To avoid contact with electrical current:

- Never install electrical wiring during an electrical storm.
- Use a screwdriver and other tools with insulated handles.
- Wear safety glasses or goggles.
- Installation of inside wiring may bring you close to electrical wire, conduit, terminals and other electrical facilities. Extreme caution must be used to avoid electrical shock from such facilities. Avoid contact with all such facilities.
- Protectors and grounding wire placed by the service provider must not be connected to, removed, or modified by the customer.
- Do not touch or move the antenna(s) while the unit is transmitting or receiving.
- Do not hold any component containing a radio such that the antenna is very close to or touching any exposed parts of the body, especially the face or eyes, while transmitting.
- Do not operate a portable transmitter near unshielded blasting caps or in an explosive environment unless it is a type especially qualified for such use.

Any external communications wiring you may install needs to be constructed to all relevant electrical codes. In the United States, this is the National Electrical Code Article 800. Contact a licensed electrician for details.

Module and development board dimensions

Module dimensions

Note: The measurements in this drawing are in inches.

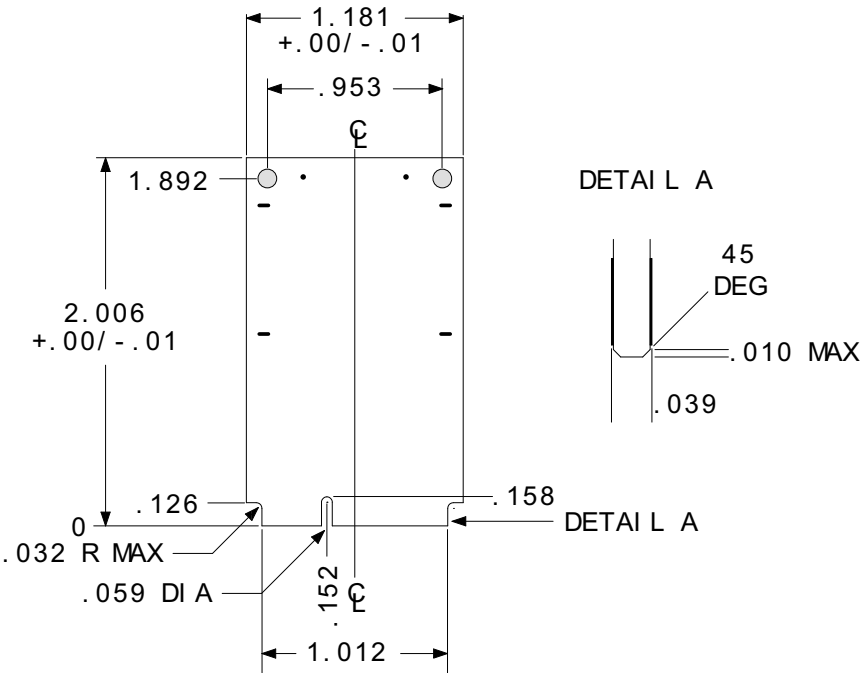

**Development
board dimensions**

Note: The measurements in this drawing are in inches.

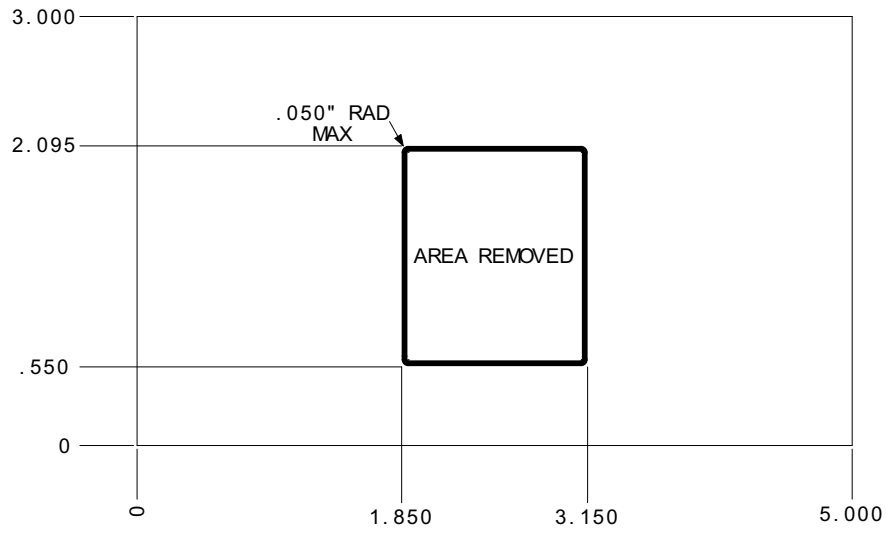

Appendix B: Certifications

The Digi Connect Wi-Wave products comply with the standards cited in this section.

FCC Part 15 Class B

.....

Radio Frequency Interface (RFI) (FCC 15.105)

The Digi Connect Wi-Wave embedded module has been tested and found to comply with the limits for Class B digital devices pursuant to Part 15 Subpart B, of the FCC rules. These limits are designed to provide reasonable protection against harmful interference in a residential environment. This equipment generates, uses, and can radiate radio frequency energy, and if not installed and used in accordance with the instruction manual, may cause harmful interference to radio communications. However, there is no guarantee that interference will not occur in a particular installation. If this equipment does cause harmful interference to radio or television reception, which can be determined by turning the equipment off and on, the user is encouraged to try and correct the interference by one or more of the following measures:

- Reorient or relocate the receiving antenna.
- Increase the separation between the equipment and receiver.
- Connect the equipment into an outlet on a circuit different from that to which the receiver is connected.
- Consult the dealer or an experienced radio/TV technician for help.

Labeling Requirements (FCC 15.19)

This device complies with Part 15 of FCC rules. Operation is subject to the following two conditions: (1) this device may not cause harmful interference, and (2) this

CERTIFICATIONS

FCC Part 15 Class B

device must accept any interference received, including interference that may cause undesired operation.

If the FCC ID is not visible when installed inside another device, then the outside of the device into which the module is installed must also display a label referring to the enclosed module FCC ID. This exterior label can use wording such as the following: *Contains Transmitter Module FCC ID: MCQ-50M1380, IC: 1846A-50M1380.*

Modifications (FCC 15.21)

Changes or modifications to this equipment not expressly approved by Digi may void the user's authority to operate this equipment.

Industry Canada

This digital apparatus does not exceed the Class B limits for radio noise emissions from digital apparatus set out in the Radio Interference Regulations of the Canadian Department of Communications.

Le present appareil numerique n'emet pas de bruits radioelectriques depassant les limites applicables aux appareils numeriques de la class B prescrites dans le Reglement sur le brouillage radioelectrique edicte par le ministere des Communications du Canada.

Declaration of Conformity

(In accordance with FCC Dockets 96-208 and 95-19)

Manufacturer's Name: Digi International
Corporate Headquarters: 11001 Bren Road East
Minnetonka MN 55343
Manufacturing Headquarters: 10000 West 76th Street
Eden Prairie MN 55344

Digi International declares, that the product:

Product Name: Digi Connect Wi-Wave
Model Numbers: 50001380-01

to which this declaration relates, meets the requirements specified by the Federal Communications Commission as detailed in the following specifications:

- Part 15, Subpart B, for Class B equipment
- FCC Docket 96-208 as it applies to Class B personal
- Personal computers and peripherals

The product listed above has been tested at an External Test Laboratory certified per FCC rules and has been found to meet the FCC, Part 15, Class B, Emission Limits. Documentation is on file and available from the Digi International Homologation Department.

International EMC Standards

The Digi Connect Wi-Wave meets the following standards:

Standards	
Emissions	EN 55022:2006 Class B EN 61000-3-2 and EN61000-3-3 EN 300 328 V1.6.1 (2004-11) AS/NZS CISPR 22:2006 ICES-003, Class B FCC Part 15 Subpart B Class B FCC Part 15 Subpart C Section 15.247 (FCC ID: MCQ-50M1380) IC RSS 210 Issue 6 and RSS GEN Issue 1 (IC: 1846A-50M1380)
Immunity	EN 55024 EN 301 489-17 V1.2.1: (2002-08)
Safety	UL 60950-1 ICE/EN 60950-1 (European Union) CSA C22.2, No. 60950-1

Index

Numerics

- 2 dBi Dipole antenna 29–31
 - attributes 29
 - dimensions 29
 - strength (radiation pattern) diagram 31
- 5.5 dBi Dipole antenna 32–34
 - attributes 32
 - dimensions 32
 - radiation pattern, E-plane 34
 - radiation pattern, H-Plane 33
- 802.11b/g modes and channels 12

A

- antenna switch 29
- antennas
 - about 27–34
 - configurations 28
 - specifications
 - 2 dBi Dipole 29
 - 5.5 dBi Dipole 32
 - switch 29
 - types 27

C

- certifications 39

D

- debug breakout header, P201 24
- development board
 - about 15–26
 - debug breakout header 24
 - dimensions 38

- features 15
- JTAG 22
- layout 16
- LEDs 19
- module connector, P52 17
- power supply 21
- reset functionality 20
- RP-SMA connectors 25
- switches 20
- U.FL connectors 25
- USB peripheral interface 23
- dimensions
 - development board 38
 - module 37
- DISABLE signal 14
- DS1 (LED) 19
- DS2 (LED) 19
- DS3, DISABLE LED 19
- DS4, WAN LED 19
- DS5, LAN LED 19
- DS6, PAN LED 19

E

- environmental specifications 35

F

- features
 - development board 15
 - module 9

G

- General 29

I

input power jack, J1 21
input power supply 21

J

J1, input power jack 21
J4, USB peripheral jack 23
JTAG header, P200 22

L

LED DS1 19
LED DS2 19
LED DS3, DISABLE 19
LED DS4, WAN 19
LED DS5, LAN 19
LED DS6, PAN 19
LEDs
 debug (signal) breakout header 19
 development board 19
 module 13

M

mechanical dimensions, module 35
module
 802.11b/g modes and channels 12
 about 9–14
 definition 9
 dimensions 37
 environmental specifications 35
 features 9
 layout 10
 LEDs 13
 mechanical dimensions 35
 module edge connector 10
 power 14
 power requirements 36
 primary interface 9
 reset generator 13
 specifications 35

USB peripheral controller 12
voltage monitor 13
voltage regulators 13
module connector, P52 17
module edge connector 10
pinout 11

P

P200, JTAG header 22
P201, debug breakout header 24
power
 development board 21
 module 14
power requirements, module 36

R

reset functionality 20
reset generator 13
RESET# 20
RF exposure statement 36
RP-SMA connectors 25

S

safety statements 36
specifications, module 35
switches 20

U

U.FL connectors 25
USB peripheral controller 12
USB peripheral interface 23
USB peripheral jack, J4 23

V

voltage monitor 13, 20
voltage regulators 13

W

W_DISABLE# signal 24

