

CMC AC Variable Speed Drive

Action Master

Series **G**

.5 – 5.4 HP 230V

**Installation, Operation and
Maintenance Instruction**



**Read this manual carefully before installing, wiring,
operating, servicing or inspecting the drive.
Keep this manual within easy reach for quick reference.**

CMC **Cleveland
Motion Controls**
An **IMC** Company

Thank you for purchasing CMC Variable Frequency Drives!

SAFETY INSTRUCTIONS

- Always follow safety instructions to prevent accidents and potential hazards from occurring.
- In this manual, safety messages are classified as follows:



WARNING

Improper operation may result in serious personal injury or death.



CAUTION

Improper operation may result in slight to medium personal injury or property damage.

- Throughout this manual we use the following two illustrations to make you aware of safety considerations:



Identifies potential hazards under certain conditions.
Read the message and follow the instructions carefully.



Identifies shock hazards under certain conditions.
Particular attention should be directed because dangerous voltage may be present.

- Keep operating instructions handy for quick reference.
- Read this manual carefully to maximize the performance of SV-ACtionMaster series inverter and ensure its safe use.



WARNING

- **Do not remove the cover while power is applied or the unit is in operation.**
Otherwise, electric shock could occur.
- **Do not run the inverter with the front cover removed.**
Otherwise, you may get an electric shock due to high voltage terminals or charged capacitor exposure.
- **Do not remove the cover except for periodic inspections or wiring, even if the input power is not applied.**
Otherwise, you may access the charged circuits and get an electric shock.

- **Wiring and periodic inspections should be performed at least 10 minutes after disconnecting the input power and after checking the DC link voltage is discharged with a meter (below DC 30V).**
Otherwise, you may get an electric shock.
- **Operate the switches with dry hands.**
Otherwise, you may get an electric shock.
- **Do not use the cable when its insulating tube is damaged.**
Otherwise, you may get an electric shock.
- **Do not subject the cables to scratches, excessive stress, heavy loads or pinching.**
Otherwise, you may get an electric shock.



CAUTION

- **Install the inverter on a non-flammable surface. Do not place flammable material nearby.**
Otherwise, fire could occur.
- **Disconnect the input power if the inverter gets damaged.**
Otherwise, it could result in a secondary accident and fire.
- **After the input power is applied or removed, the inverter will remain hot for a couple of minutes.**
Otherwise, you may get bodily injuries such as skin-burn or damage.
- **Do not apply power to a damaged inverter or to an inverter with parts missing even if the installation is complete.**
Otherwise, electric shock could occur.
- **Do not allow lint, paper, wood chips, dust, metallic chips or other foreign matter into the drive.**
Otherwise, fire or accident could occur.

OPERATING PRECAUTIONS

(1) Handling and installation

- Handle according to the weight of the product.
- Do not stack the inverter boxes higher than the number recommended.
- Install according to instructions specified in this manual.
- Do not open the cover during delivery.
- Do not place heavy items on the inverter.
- Check the inverter mounting orientation is correct.
- Do not drop the inverter, or subject it to impact.
- Follow your national electrical code for grounding. Recommended Ground impedance for 200 V Class is below 100 ohm and for 400V class is below 10 ohm.
- ACTIONMASTER series contains ESD (Electrostatic Discharge) sensitive parts. Take protective measures against ESD (Electrostatic Discharge) before touching the pcb for inspection or installation.
- Use the inverter under the following environmental conditions:

Environment	Ambient temperature	- 10 ~ 40 °C (non-freezing)
	Relative humidity	90% RH or less (non-condensing)
	Storage temperature	- 20 ~ 65 °C
	Location	Protected from corrosive gas, combustible gas, oil mist or dust
	Altitude, Vibration	Max. 1,000m above sea level, Max. 5.9m/sec ² (0.6G) or less
	Atmospheric pressure	70 ~ 106 kPa

(2) Wiring

- Do not connect a power factor correction capacitor, surge suppressor, or RFI filter to the output of the inverter.
- The connection orientation of the output cables U, V, W to the motor will affect the direction of rotation of the motor.
- Incorrect terminal wiring could result in the equipment damage.
- Reversing the polarity (+/-) of the terminals could damage the inverter.
- Only authorized personnel familiar with CMC inverter should perform wiring and inspections.
- Always install the inverter before wiring. Otherwise, you may get an electric shock or have bodily injury.

(3) Trial run

- Check all parameters during operation. Changing parameter values might be required depending on the load.
- Always apply permissible range of voltage to the each terminal as indicated in this manual. Otherwise, it could lead to inverter damage.

(4) Operation precautions

- When the Auto restart function is selected, stay away from the equipment as a motor will restart suddenly after an alarm stop.
- The Stop key on the keypad is valid only when the appropriate function setting has been made. Prepare an emergency stop switch separately.
- If an alarm reset is made with the reference signal present, a sudden start will occur. Check that the reference signal is turned off in advance. Otherwise an accident could occur.
- Do not modify or alter anything inside the inverter.
- Motor might not be protected by electronic thermal function of inverter.
- Do not use a magnetic contactor on the inverter input for frequent starting/stopping of the inverter.
- Use a noise filter to reduce the effect of electromagnetic interference. Otherwise nearby electronic equipment may be affected.
- In case of input voltage unbalance, install AC reactor. Power Factor capacitors and generators may become overheated and damaged due to potential high frequency noise transmitted from inverter.
- Use an insulation-rectified motor or take measures to suppress the micro surge voltage when driving 400V class motor with inverter. A micro surge voltage attributable to wiring constant is generated at motor terminals, and may deteriorate insulation and damage motor.
- Before operating unit and prior to user programming, reset user parameters to default settings.
- Inverter can easily be set to high-speed operations, Verify capability of motor or machinery prior to operating unit.
- Stopping torque is not produced when using the DC-Break function. Install separate equipment when stopping torque is needed.

(5) Fault prevention precautions

- Provide a safety backup such as an emergency brake which will prevent the machine and equipment from hazardous conditions if the inverter fails.

(6) Maintenance, inspection and parts replacement

- Do not conduct a megger (insulation resistance) test on the control circuit of the inverter.
- Refer to Chapter 6 for periodic inspection (parts replacement).

(7) Disposal

- Handle the inverter as an industrial waste when disposing of it.

(8) General instructions

- Many of the diagrams and drawings in this instruction manual show the inverter without a circuit breaker, a cover or partially open. Never run the inverter like this. Always place the cover with circuit breakers and follow this instruction manual when operating the inverter.

CONTENTS

USER SELECTION GUIDE (ACTIONMASTER SPECIFICATIONS)	3
CHAPTER 1 - INSTALLATION	5
1.1 Inspection	5
1.2 Environmental Conditions.....	5
1.3 Mounting	5
1.4 Other Precautions	6
1.5 Dimensions	7
1.6 Basic Wiring	9
1.7 Power Terminals	10
1.8 Control Terminals	13
CHAPTER 2 - OPERATION	16
2.1 Keypad and Parameter Group Setting	16
2.2 Parameter Setting and Change	17
2.3 Parameter Group.....	19
2.4 Operation	22
CHAPTER 3 - PARAMETER LIST	24
3.1 Drive Group [DRV].....	24
3.2 Function Group 1 [FU1]	25
3.3 Function Group 2 [FU2]	27
3.4 Input/Output Group [I/O]	30
CHAPTER 4 - PARAMETER DESCRIPTION	34
4.1 Drive Group [DRV].....	34
4.2 Function 1 Group [FU1]	39
4.3 Function 2 Group [FU2]	50
4.4 Input/Output Group [I/O]	62
CHAPTER 5 - MODBUS-RTU COMMUNICATION	74
5.1 Introduction.....	74
5.2 Specifications	74
5.3 Installation	75
5.4 Operating	76
5.5 Communication Protocol (Modbus-RTU)	76
5.6 Communication Protocol (CMC-BUS ASCII).....	77
5.7 Parameter Code List.....	81
5.8 Troubleshooting.....	87
5.9 ASCII Code List.....	89

CHAPTER 6 - TROUBLESHOOTING & MAINTENANCE 90

- 6.1 Fault Display 90
- 6.2 Fault (Inverter Fault) Reset 92
- 6.3 Fault Remedy..... 93
- 6.4 Troubleshooting 94
- 6.5 How to Check Power Components..... 95
- 6.6 Maintenance 96
- 6.7 Daily and Periodic Inspection Items 97

CHAPTER 7 - OPTIONS..... 100

- 7.1 Braking Resistor..... 100
- 7.2 DIN Rail Base 102

APPENDIX A - FUNCTIONS BASED ON THE USE..... 104

APPENDIX B- PERIPHERAL DEVICES 105

DECLARATION OF CONFORMITY 106

USER SELECTION GUIDE (ACTIONMASTER SPECIFICATIONS)

230V Class (0.5~5.4HP)

Inverter Type (SVxxxActionMaster -x)		004-1	008-1	015-1	004-2	008-2	015-2	022-2	037-2	040-2
Motor Rating ¹	HP	0.5	1	2	0.5	1	2	3	5	5.4
	kW	0.37	0.75	1.5	0.37	0.75	1.5	2.2	3.7	4.0
Output Ratings	Capacity ² [kVA]	1.1	1.9	3.0	1.1	1.9	3.0	4.5	6.1	6.5
	FLA [A]	3	5	8	3	5	8	12	16	17
	Frequency	0.1 ~ 400 Hz								
	Voltage	200 ~ 230 V ³								
Input Ratings	Voltage	1 Phase 200 ~ 230 V (± 10 %)			3 Phase 200 ~ 230 V (± 10 %)					
	Frequency	50 ~ 60 Hz (±5 %)								
Dynamic Braking	Braking Circuit	On Board								
	Average Braking Torque	20 % (Optional External DB Resistor: 100%, 150%)								
	Max. Continuous Braking Time	15 seconds								
	Duty	0 ~ 30 % ED								
Weight [lbs]		2.65	3.97	4.63	2.65	2.65	3.97	4.63	4.85	4.85

460V Class (0.5~ 5.4HP)

Inverter Type (SVxxxActionMaster -x)		004-4	008-4	015-4	022-4	037-4	040-4
Motor Rating ¹	HP	0.5	1	2	3	5	5.4
	kW	0.37	0.75	1.5	2.2	3.7	4.0
Output Ratings	Capacity ² [kVA]	1.1	1.9	3.0	4.5	6.1	6.5
	FLA [A]	1.5	2.5	4	6	8	9
	Frequency	0.1 ~ 400 Hz					
	Voltage	380 ~ 460 V ³					
Input Ratings	Voltage	3 Phase, 380 ~ 460 V (± 10 %)					
	Frequency	50 ~ 60 Hz (±5 %)					
Dynamic Braking	Braking Circuit	On Board					
	Average Braking Torque	20 % (Optional External DB Resistor: 100%, 150%)					
	Max. Continuous Braking Time	15 seconds					
	Duty	0 ~ 30 % ED					
Weight [lbs]		3.75	3.75	3.97	4.63	4.85	4.85

¹ Indicates the maximum applicable capacity when using a 4 pole motor.

² Rated capacity ($\sqrt{3 \cdot V \cdot I}$) is based on 220V for 200V class and 440V for 400V class.

³ Maximum output voltage will not be greater than input voltage. Output voltage less than input voltage may be programmed.

CONTROL	Control Method		V/F Control	
	Frequency Setting Resolution		Digital Reference: 0.01 Hz (Below 100 Hz), 0.1 Hz (Over 100 Hz) Analog Reference: 0.03 Hz / 50 Hz	
	Frequency Accuracy		Digital: 0.01 % of Max. Output Frequency, Analog: 0.1 % of Max. Output Frequency	
	V/F Ratio		Linear, Square Patter, User V/F	
	Overload Capacity		150 % of Rated Current for 1 Min. (Characteristic is inversely Proportional to Time)	
	Torque Boost		Manual Torque Boost (0 ~ 15 %), Auto Torque Boost	
OPERATION	Input Signal	Operation Method		Key / Terminal / Communication Operation
		Frequency Setting		Analog: 0 ~ 10V / 4 ~ 20 mA Digital: Keypad
		Start Signal		Forward, Reverse
		Multi-Step Speed		Up to 8 Speeds Can Be Set (Use Multi-Function Terminal)
		Multi Step Accel/Decel Time		0 ~ 9,999 sec, Up to 4 Types Can Be Set and Selected for Each Setting (Use Multi-Function Terminal), Accel/Decel Pattern: Linear Pattern, U Pattern, S Pattern
		Emergency Stop		Interrupts the Output of Inverter
		Jog		Jog Operation
		Fault Reset		Reset Faults When Protective Function is Active
	Output Signal	Operating Status		Frequency Level Detection, Overload Alarm, Stalling, Over Voltage, Under Voltage, Inverter Overheating, Running, Stop, Constant Speed, Speed Searching
		Fault Output		Contact Output (A, C, B) – AC250V 1A, DC30V 1A
		Indicator		Choose One From Output Frequency, Output Current, Output Voltage, DC Voltage (Output Voltage: 0 ~ 10V)
Operation Function		DC Braking, Frequency Limit, Frequency Jump, Second Function, Slip Compensation, Reverse Rotation Prevention, Auto Restart, PID Control		
Protection	Inverter Trip		Over Voltage, Under Voltage, Over Current, Inverter Overheating, Motor Over heating, Input/Output Phase Loss, Overload Protection, Communication Error, Loss of Speed Command, Hardware Fault	
	Inverter Alarm		Stall Prevention, Overload Alarm	
	Momentary Power Loss		Less than 15 msec: Continuous Operation, More than 15 msec: Auto Restart (Programmable)	
Display	Keypad	Operation Information		Output Frequency, Output Current, Output Voltage, Frequency Value Setting, Operating Speed, DC Voltage
		Trip Information		Indicates Fault when Protection Function Activated, Memorizes Up to 5 Faults
Environment	Ambient Temperature		-10 °C ~ 40 °C (14 °F ~ 104 °F), <i>CE Certification: 41 °F ~ 104 °F (5 °C ~ 40 °C)</i>	
	Storage Temperature		-20 °C ~ 65 °C (-4 °F ~ 149 °F)	
	Ambient Humidity		Less Than 90 % RH Max. (Non-Condensing), <i>CE Certification: 5 ~85% (Non-Condensing)</i>	
	Altitude / Vibration		Below 1,000 m · Below 5.9m/sec ² (=0.6g)	
	Application Site		No Corrosive Gas, Combustible Gas, Oil Mist, or Dust	
	Atmospheric Pressure		70 ~ 106kPa	
Cooling Method		Forced Air Cooling ⁴		

⁴ 'Self-cooling' for model SV004ActionMaster -4, SV008ActionMaster -4.

CHAPTER 1 - INSTALLATION

1.1 Inspection

- ✓ Inspect the inverter for any damage that may have occurred during shipping.
- ✓ Check the nameplate on the ACtionMaster inverter. Verify the inverter unit is the correct one for the application. The numbering system of the inverter is as shown below.

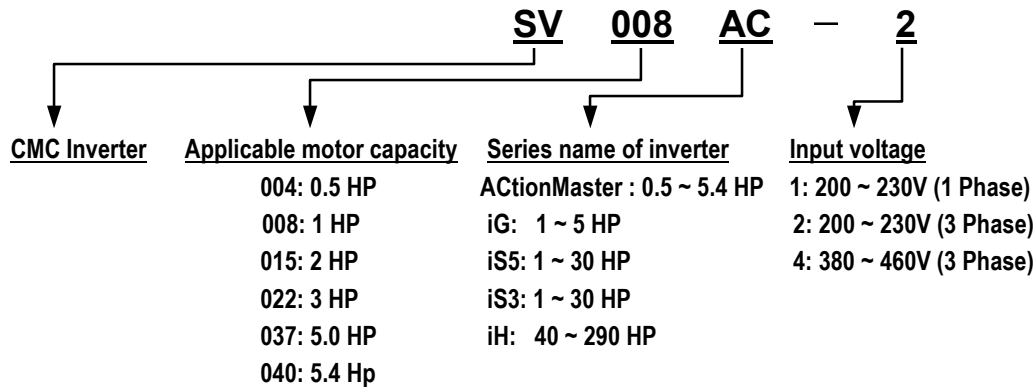

1.2 Environmental Conditions

- ✓ Verify the ambient condition for the mounting location.
 - Ambient temperature should not be below 14°F (-10°C) or exceed 104°F (40°C).
 - Relative humidity should be less than 90% (non-condensing).
 - Altitude should be below 3,300ft (1,000m).
- ✓ Do not mount the inverter in direct sunlight and isolate it from excessive vibration.
- ✓ If the inverter is going to be installed in an environment with high probability of penetration of dust, it must be located inside watertight electrical boxes, in order to get the suitable IP degree.

1.3 Mounting

- ✓ The inverter must be mounted vertically with sufficient horizontal and vertical space between adjacent equipment (A= Over 6" (150mm), B= Over 2"(50mm)).

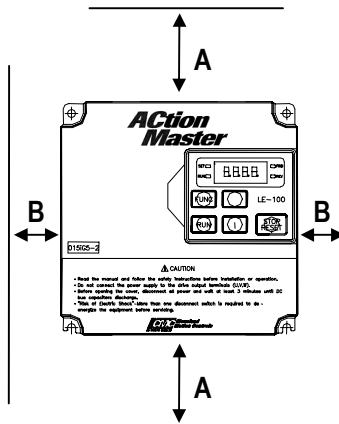

1.4 Other Precautions

- ✓ Do not carry the inverter by the front cover.
- ✓ Do not install the inverter in a location where excessive vibration is present. Be cautious when installing on presses or moving equipment.
- ✓ The life span of the inverter is greatly affected by the ambient temperature. Install in a location where temperature are within permissible limits (-10 ~ 40°C) (14~104°F).
- ✓ The inverter operates at high-temperatures - install on a non-combustible surface.
- ✓ Do not install the inverter in high-temperature or high-humidity locations.
- ✓ Do not install the inverter in a location where oil mist, combustible gas, or dust is present. Install the inverter in a clean location or in an enclosed panel, free of foreign substance.
- ✓ When installing the inverter inside a panel with multiple inverters or a ventilation fan, use caution. If installed incorrectly, the ambient temperature may exceed specified limits.

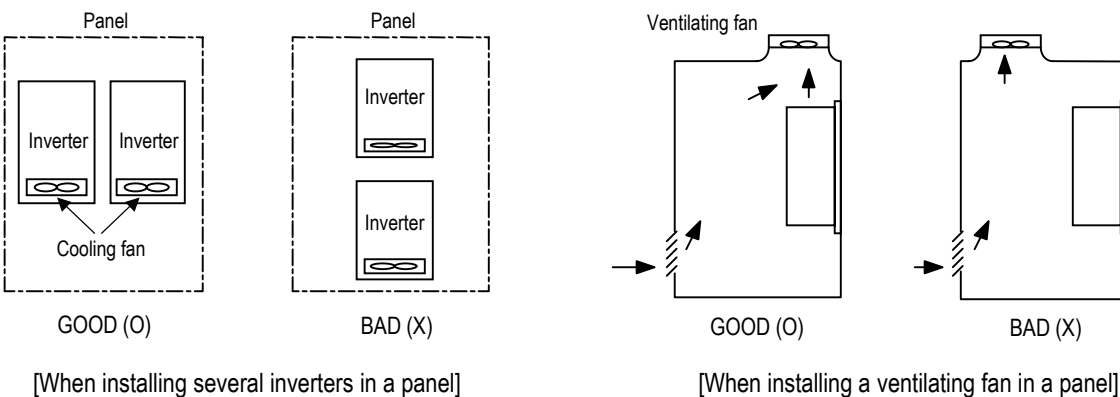

- ✓ Install the inverter using screws or bolts to insure the inverter is firmly fastened.
- ✓ **If Carrier Frequency (FU2-39) must be set higher than 3 kHz, derate the load current by 5% per 1 kHz.**

1.5 Dimensions

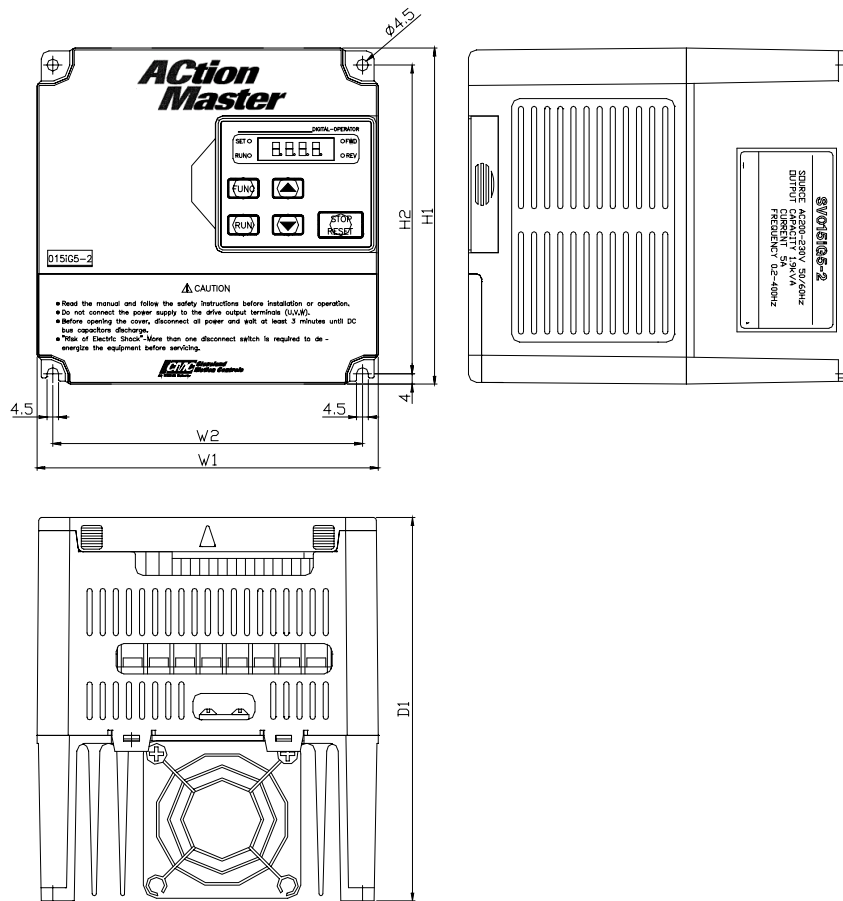

Unit: mm (inch)

Inverter	HP	W1	W2	H1	H2	D1
SV004ActionMaster-1	0.5	100 (3.94)	88 (3.46)	128 (5.04)	117.5 (4.63)	130.9 (5.15)
SV008ActionMaster-1	1	130 (5.12)	118 (4.65)	128 (5.04)	117.5 (4.63)	152.9 (6.02)
SV015ActionMaster-1	2	150 (5.90)	138 (5.43)	128 (5.04)	117.5 (4.63)	155.0 (6.10)
SV004ActionMaster-2	0.5	100 (3.94)	88 (3.46)	128 (5.04)	117.5 (4.63)	130.9 (5.15)
SV008ActionMaster-2	1	100 (3.94)	88 (3.46)	128 (5.04)	117.5 (4.63)	130.9 (5.15)
SV015ActionMaster-2	2	130 (5.12)	118 (4.65)	128 (5.04)	117.5 (4.63)	152.9 (6.02)
SV022ActionMaster-2	3	150 (5.90)	138 (5.43)	128 (5.04)	117.5 (4.63)	155.0 (6.10)

Chapter 1 - Installation

SV037ActionMaster -2	5.0	150 (5.90)	138 (5.43)	128 (5.04)	117.5 (4.63)	155.0 (6.10)
SV040ActionMaster -2	5.4	150 (5.90)	138 (5.43)	128 (5.04)	117.5 (4.63)	155.0 (6.10)
SV004ActionMaster -4	0.5	130 (5.12)	118 (4.65)	128 (5.04)	117.5 (4.63)	152.9 (6.02)
SV008ActionMaster -4	1	130 (5.12)	118 (4.65)	128 (5.04)	117.5 (4.63)	152.9 (6.02)
SV015ActionMaster -4	2	130 (5.12)	118 (4.65)	128 (5.04)	117.5 (4.63)	152.9 (6.02)
SV022ActionMaster -4	3	150 (5.90)	138 (5.43)	128 (5.04)	117.5 (4.63)	155.0 (6.10)
SV037ActionMaster -4	5.0	150 (5.90)	138 (5.43)	128 (5.04)	117.5 (4.63)	155.0 (6.10)
SV040ActionMaster -4	5.4	150 (5.90)	138 (5.43)	128 (5.04)	117.5 (4.63)	155.0 (6.10)

1.6 Basic Wiring

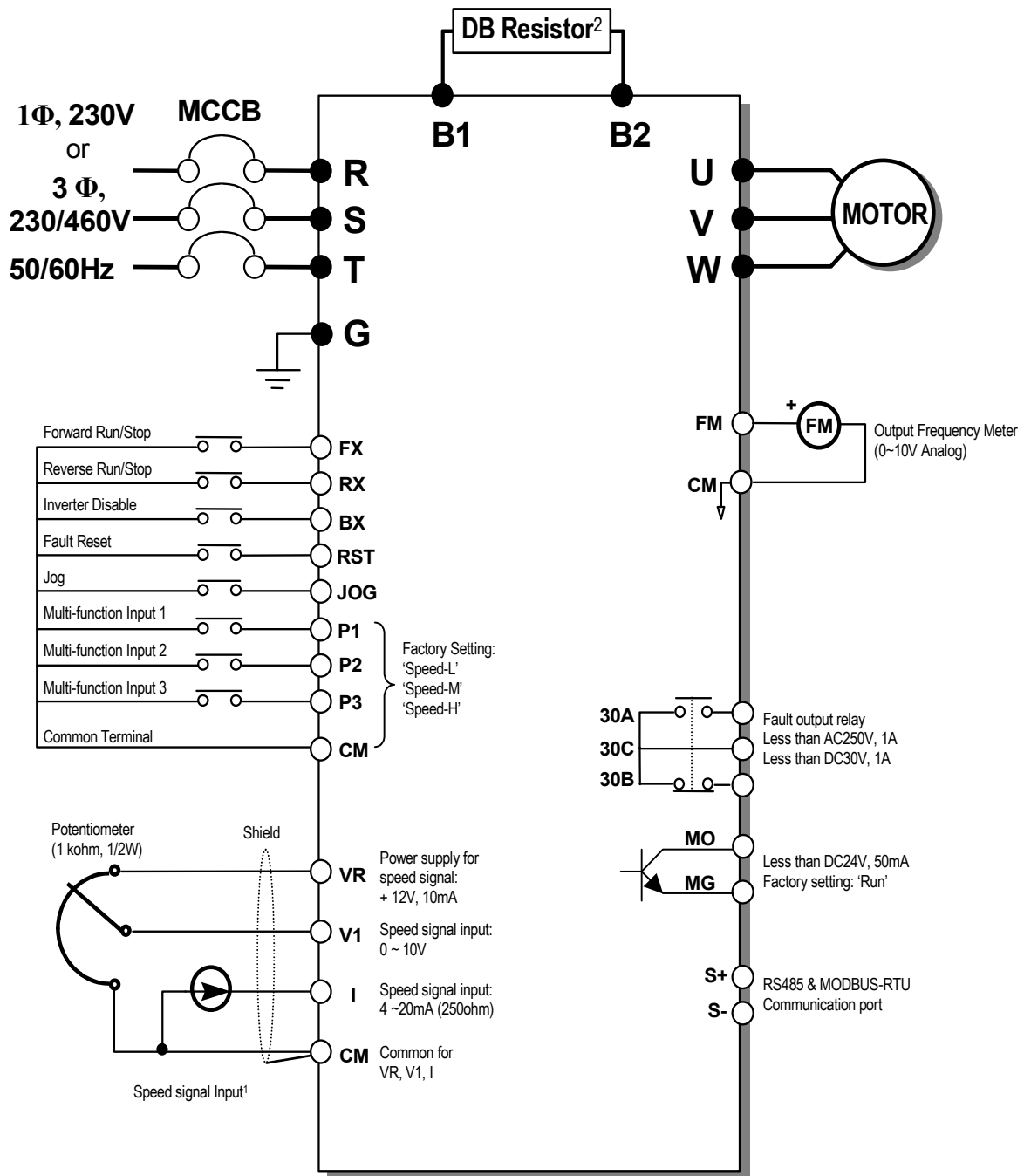

Note) ● display main circuit terminals, ○ display control circuit terminals.
 1. Analog speed command can be set by Voltage, Current and both of them.
 2. DB resistor is optional.

1.7 Power Terminals

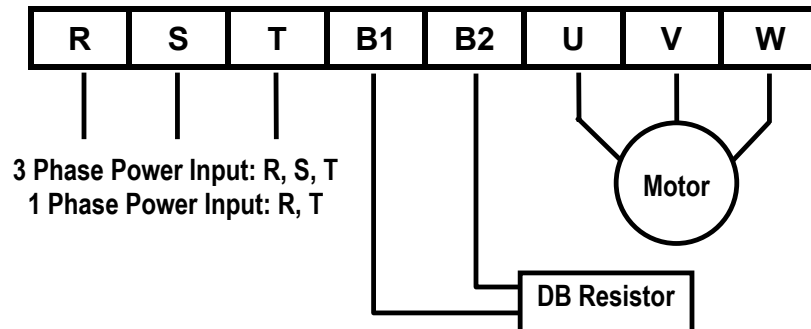

Symbols	Functions
R	AC Line Input Terminals 3(1) phase, 200 ~ 230V AC for 200V Class Units and 380 ~ 460V AC for 400V Class Units.
S	
T	
U	3 Phase Output Terminals to Motor (3 Phase, 200 ~ 230VAC or 380 ~ 460VAC)
V	
W	
B1	Dynamic Braking Resistor Connection Terminals
B2	

“Suitable for use on a circuit capable of delivering not more than 10,000 rms symmetrical amperes, 240 volts maximum for 230V class models and 480 volts maximum for 460V class models.”



WARNING

Normal stray capacitance between the inverter chassis and the power devices inside the inverter and AC line can provide a high impedance shock hazard. Do not apply power to the inverter if the inverter frame (Power terminal G) is not grounded.

1.7.1 Wiring Power Terminals

■ Precautions on Wiring WARNING

- ✓ The internal circuits of the inverter will be damaged if the incoming power is connected and applied to output terminals (U, V, W).
- ✓ Use ring terminals with insulated caps when wiring the input power and motor wiring.
- ✓ Do not leave wire fragments inside the inverter. Wire fragments can cause faults, breakdowns, and malfunctions.

- ✓ For input and output, use wires with sufficient size to ensure voltage drop of less than 2%. Motor torque may drop if operating at low frequencies and a long wire run between inverter and motor.
- ✓ When more than one motor is connected to one inverter, total wiring length should be less than 500m (1,640ft). Do not use a 3-wire cable for long distances. Due to increased leakage capacitance between wires, over-current protective feature may operate or equipment connected to the output side may malfunction.
- ✓ Connect only recommended braking resistor between the B1 and B2 terminals. **Never short B1 and B2 terminals. Shorting terminals may cause internal damage to inverter.**
- ✓ The main circuit of the inverter contains high frequency noise, and can hinder communication equipment near the inverter. To reduce noise, install RFI filters or line noise filters on the input side of the inverter.
- ✓ Do not use power factor capacitor, surge suppressors, or RFI filters on the output side of the inverter. Doing so may damage these components.
- ✓ Always insure the LED and charge lamp for the power terminal are OFF before wiring terminals. The charge capacitor may hold high-voltage even after the power is disconnected. Use caution to prevent the possibility of personal injury.

■ **Grounding**  **WARNING**

- ✓ The inverter is a high switching device, and leakage current may flow. Ground the inverter to avoid electrical shock. Use caution to prevent the possibility of personal injury.
- ✓ Connect only to the dedicated ground terminal on the inverter. Do not use the enclosure or a chassis screw for grounding.
- ✓ The protective earth conductor must be the first one in being connected and the last one in being disconnected.
- ✓ As a minimum, grounding wire should meet the specifications listed below. Grounding wire should be as short as possible and should be connected to the ground point as near as possible to the inverter.

Motor Capacity	Grounding Wire Sizes, AWG (mm ²)	
	200V class	400V class
0.5 ~ 5.4 HP	12 (3.5)	14 (2)

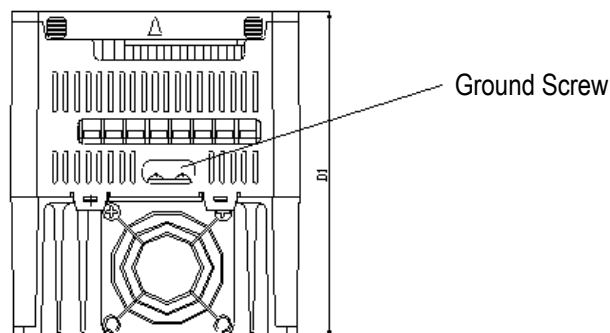

Chapter 1 - Installation

■ Wires and Terminal Lugs

Refer to the following table for wires, terminal lugs and screws used to connect the inverter power input (R, S, T) and output (U, V, W).

Inverter		Terminal Screw Size	Screw Torque ⁵ (Kgf-cm)/lb-in	Ring Terminals		Wire ⁶			
						mm ²		AWG	
				R,S,T	U,V,W	R,S,T	U,V,W	R,S,T	U,V,W
200V Class (1 Phase)	0.5 HP	M 3.5	10 / 7	2-3.5	2-3.5	2	2	14	14
	1 ~ 2 HP	M 4.0	15 / 10	2-4	2-4	2	2	14	14
200V Class (3 Phase)	0.5 ~ 1 HP	M 3.5	10 / 7	2-3.5	2-3.5	2	2	14	14
	2 ~ 3 HP	M 4.0	15 / 10	2-4	2-4	2	2	14	14
	5 ~ 5.4 HP	M 4.0	15 / 10	5.5-4	5.5-4	3.5	3.5	12	12
400V Class (3 Phase)	0.5 ~ 5.4 HP	M 4.0	15 / 10	2-4	2-4	2	2	14	14

■ Power and Motor Connection

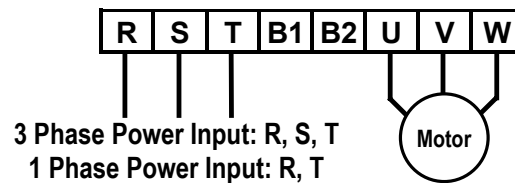

WARNING

Power supply must be connected to the R, S, and T Terminals. Connecting it to the U, V, W terminals causes internal damages to the inverter. Arranging the phase sequence is not necessary.



WARNING

Motor should be connected to the U, V, and W Terminals. If the forward command (FX) is on, the motor should rotate counter clockwise when viewed from the load side of the motor. If the motor rotates in the reverse, switch the U and V terminals.

⁵ Apply the rated torque to terminal screws. Loosen screws can cause of short circuit and malfunction. Tightening the screws too much can damage the terminals and cause short circuit and malfunction.

⁶ Use copper wires with 600V, 75°C ratings for wiring only.

1.8 Control Terminals

30A	30C	30B
-----	-----	-----

1	2	3	4	5	6	7	8	9	10	1	2	3	4	5	6	7	8	9	10
MO	MG	CM	FX	RX	CM	BX	JOG	RST	CM	P1	P2	P3	VR	V1	CM	I	FM	S+	S-

Terminal Name	Terminal Screw Size	Screw Torque (Kgf-cm/lb-in)	Wire Size		Stripped Length (mm)
			Solid Wire (mm ²)	Stranded Wire (mm ²)	
30A, 30C, 30B	M3	5 / 3.6	2.5	1.5	7
MO, MG, CM, FX, RX ~ S-	M2	4 / 2.9	1.5	1.0	5.5

Type	Symbol	Name	Description
Input signal	Starting Contact Function Select	P1, P2, P3	Multi-Function Input 1, 2, 3 Used for Multi-Function Input. Default is set to "Step Frequency 1, 2, 3".
		FX	Forward Run Command Forward Run When Closed and Stop When Open.
		RX	Reverse Run Command Reverse Run When Closed and Stop When Open.
		JOG	Jog Frequency Reference Runs at Jog Frequency. The Direction is set by the FX (or RX) Signal.
		BX	Emergency Stop  When the BX Signal is ON Output of Inverter is Turned Off. When Motor uses an Electrical Brake to Stop, BX is used to Turn Off the Output Signal. When BX Signal is OFF (Not Turned Off by Latching) and FX Signal (or RX Signal) is ON, Motor continues to Run.
		RST	Fault Reset Used for Fault Reset.
	Analog frequency setting	CM	Sequence Common Common Terminal for Contact Inputs.
		VR	Frequency Setting Power (+10V) Used as Power for Analog Frequency Setting. Maximum Output is +12V, 10mA.
		V1	Frequency Reference (Voltage) Used for 0-10V Input Frequency Reference. Input Resistance is 20 K Ω
		I	Frequency Reference (Current) Used for 4-20mA Input Frequency Reference. Input Resistance is 250 Ω
Output signal	Analog	CM	Frequency Setting Common Terminal Common Terminal for Analog Frequency Reference Signal and FM (For Monitoring).
	Contact	FM-CM	Analog Output (For External Monitoring) Outputs One of the Following: Output Frequency, Output Current, Output Voltage, DC Link Voltage. Default is set to Output Frequency. Maximum Output Voltage and Output Current are 0-12V and 1mA.
		30A 30C 30B	Fault Contact Output Activates when Protective Function is Operating. AC250V, 1A or less; DC30V, 1A or less. Fault: 30A-30C Short (30B-30C Open), Normal: 30B-30C Short (30A-30C Open)
	MO - MG	Multi-Function Output (Open Collector Output) Use After Defining Multi-Function Output Terminal. DC24V, 50mA or less.	
RS-485	S+, S-	Communication Port	Communication Port for MODBUS-RTU Communication

Chapter 1 - Installation

1.8.1 Wiring Control Terminals

■ Precautions on Wiring

- ✓ Use shielded wires or twisted wires for control circuit wiring, and separate these wires from the main power circuits and other high voltage circuits.

■ Control Circuit Terminal

- ✓ The input terminals can be selected for either NPN or PNP type logic by changing switch J1. CM terminal is the common terminal for the input signals.

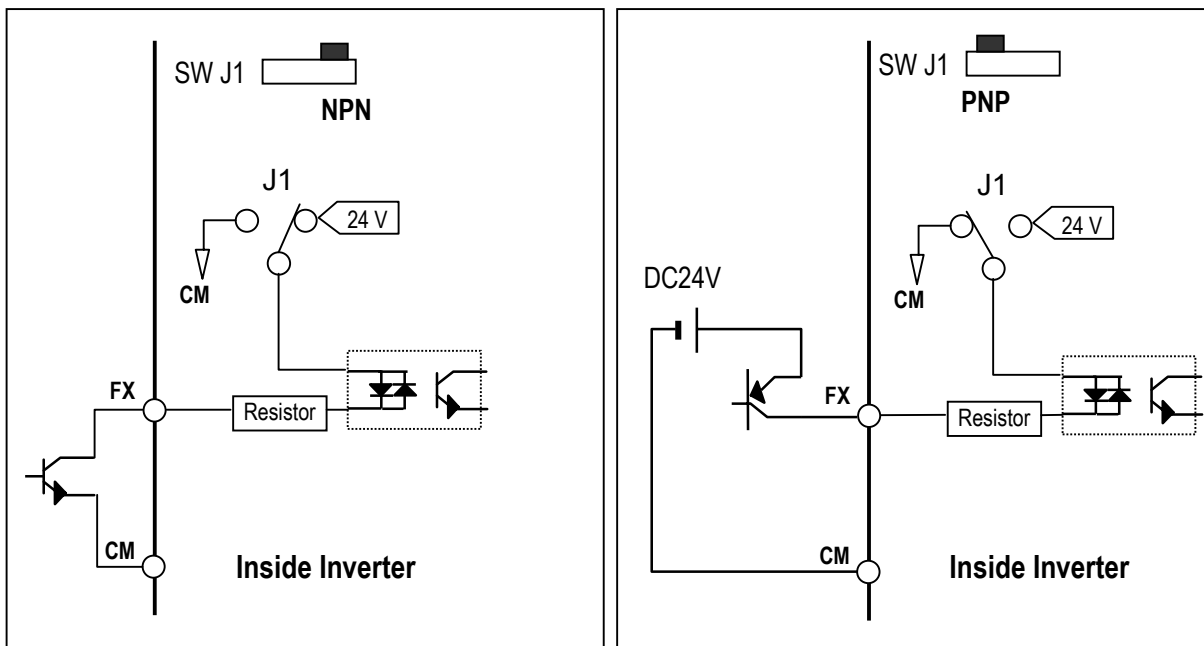

CAUTION

Do not apply voltage to any control input terminals (FX, RX, P1, P2, P3, JOG, BX, CM, etc).

1.8.2 Keypad

■ Wiring the Keypad

Keypad is installed before shipping for standard type models as shown below. When using an optional remote cable, install the buffer cover and connect the remote cable. If the keypad is not connected properly, the letters will not be displayed.

- ☞ **Note:** Do not connect the keypad and remote cable while the inverter is under power.
- ☞ **Note:** Do not touch the live part of the keypad connector. Doing this may cause an electric shock or personal injury.

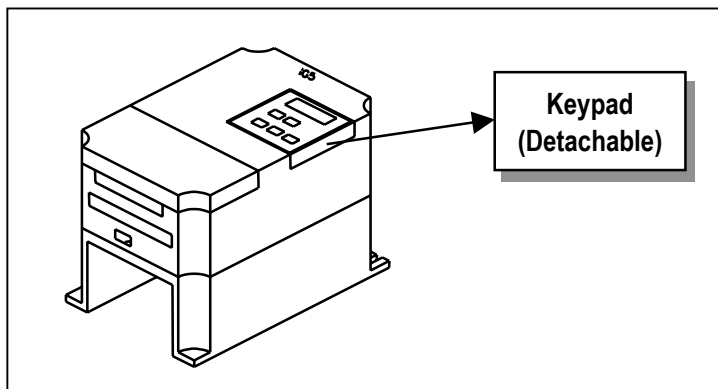

■ Keypad Connector Pin Configuration (Inverter Side)

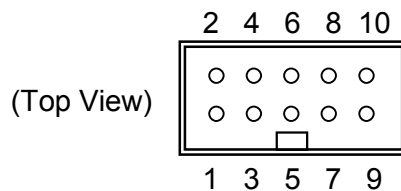

Pin No.	Pin Name	Keypad	Description
1	5V	Used	5V DC Power Supply (Isolated from VR, V1, I of Control Terminal)
2	GND	Used	5V DC Power Ground (Isolated from CM of Control Terminal)
3	RES	Used	Used for Writing Flash ROM Inside Inverter.
4	VPP	Used	
5	LAT	Used	Latch Signal for Transmitting/Receiving
6	TXD	Used	Transmitting Signal Pin
7	CLK	Used	Clock Signal Pin
8	RXD	Used	Receiving Signal Pin
9		Not Used	
10		Not Used	

CHAPTER 2 - OPERATION

2.1 Keypad and Parameter Group Setting

2.1.1 Keypad Description

7-Segment keypad displays up to 4 letters and numbers, and the user can directly check various settings of the inverter. The following is an illustration of the keypad and the functions of each part.

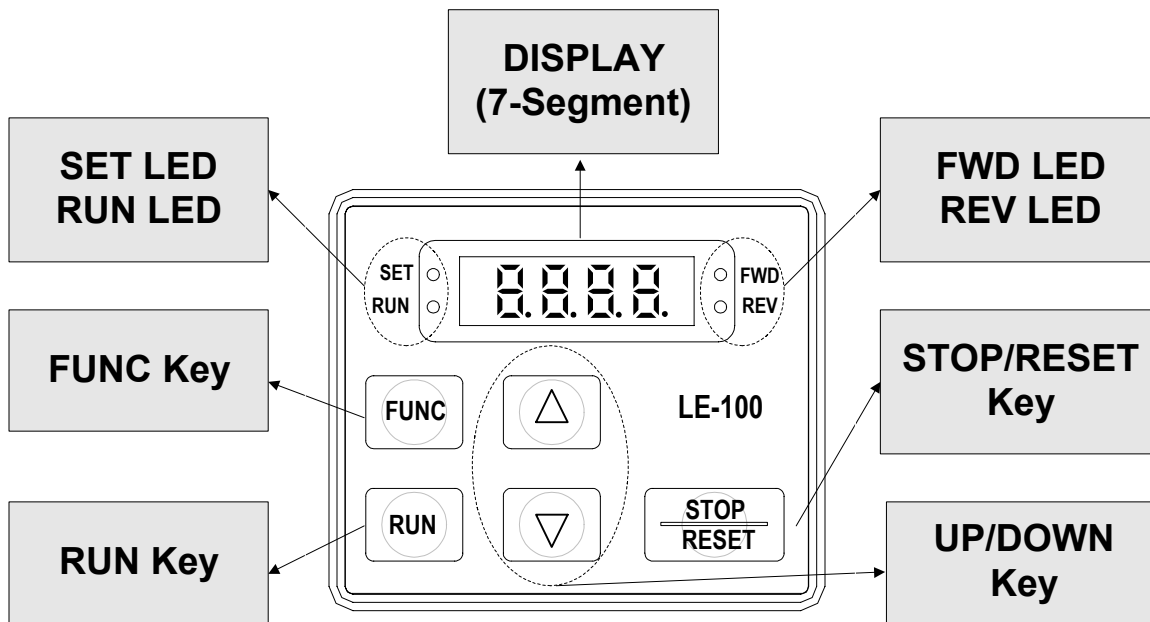

Class	Display	Name	Description
Key	FUNC	Program Key	Press to Change Parameter Setting.
	▲ (Up)	Up Key	Press to Move Through Codes or To Increase Parameter Values.
	▼ (Down)	Down Key	Press to Move Through Codes or To Decrease Parameter Values.
	RUN	Run Key	Use to Operate Inverter.
	STOP/RESET	STOP/RESET Key	Press to Stop Inverter During Operation. Press to Reset When a Fault Has Occurred.
LED	REV	Reverse Run Display	Lit During Reverse Run.
	FWD	Forward Run Display	Lit During Forward Run.
	SET	Setting	Lit When User is Setting Parameters Using FUNC Key
	RUN	Operating	Lit When at Constant Speed and Blinks When Accelerating or Decelerating.

2.2 Parameter Setting and Change

Numerous parameters are built into the inverter. The keypad allows the operator to operate the inverter by setting the required parameters, and enter the proper value according to the load and operating conditions. Refer to Chapter 4 'PARAMETER DESCRIPTION' for detailed description of the functions.

■ Procedures

First move to the group code that needs changing.

Press [FUNC] key. The keypad LED (SET) will turn ON.

Use the [▲ (Up)], [▼ (Down)] keys to set the data to the desired value.

Press [FUNC] key again. The data display will blink and the data will be stored in the inverter.

☞ **Note:** If the data does not changed, determine if:

- Inverter is running (Refer to the function table in Chapter 3)
- Function is locked in H 94 [Parameter Lock]

■ Setting the DRV Group Data

Example) Change the acceleration time from 60 sec to 40 sec:

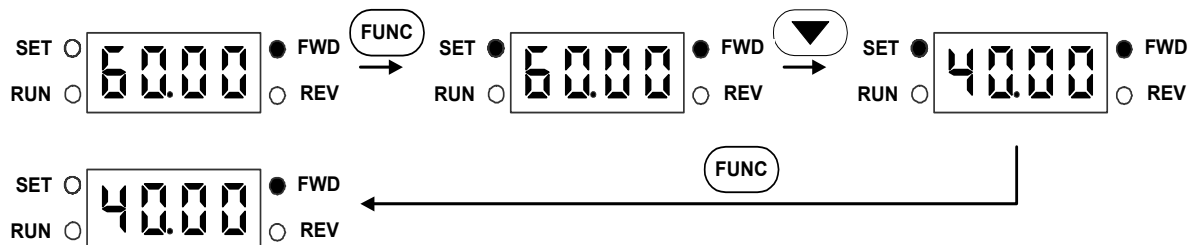

Data will blink when the data setting is finished. Indicates data programming is complete.

■ To Monitor Current Output from the DRV Group

Example) Monitor current output from inverter (Data cannot be set):



■ To Monitor Fault Type when a Fault Occurs (Data cannot be set)

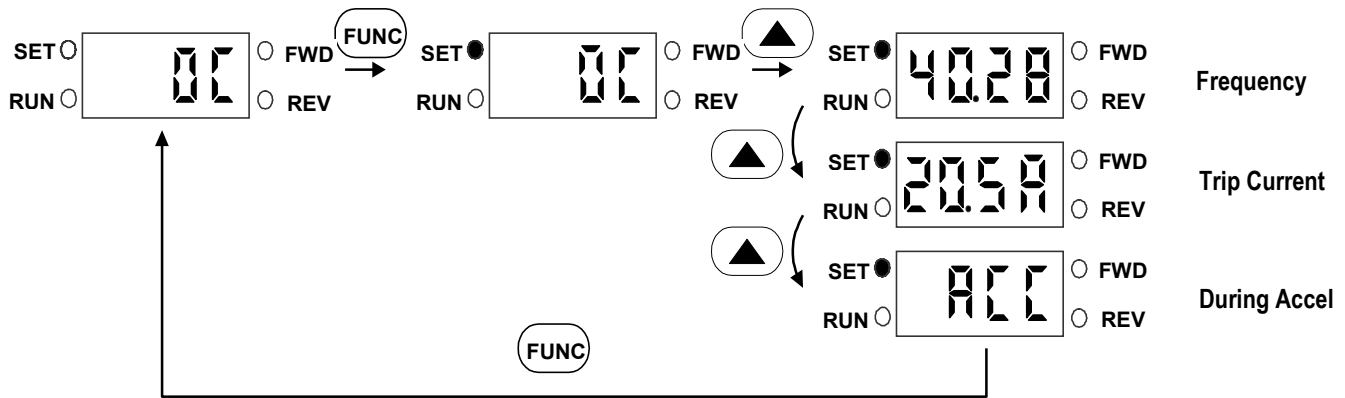

The fault type is displayed on the DRV group when a fault occurs. Frequency, current and operating status (accelerating, decelerating, in constant speeds) may be monitored by using the UP, DOWN arrow keys.

(Ex: Fault occurred when the inverter was accelerating at 40.28 Hz, 20.5A) 4 LED is blinking in this situation.

Fault status can be removed by using the STOP/RESET Key, and the LED turns OFF.

(The inverter must be turned OFF and turned ON again to remove HW fault status.)

■ Adjusting Function and I/O Group Data

Example) Changing the F5 data to 1:

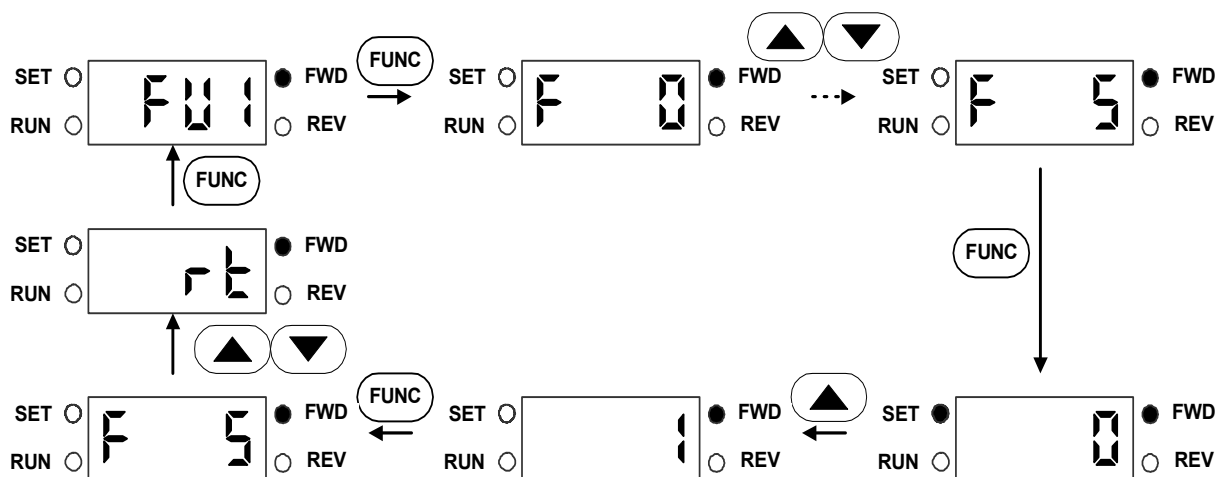

■ **Setting Jump Code in Function Group**

Example) Jump to code FU1-12 from FU1-0 (F 0):

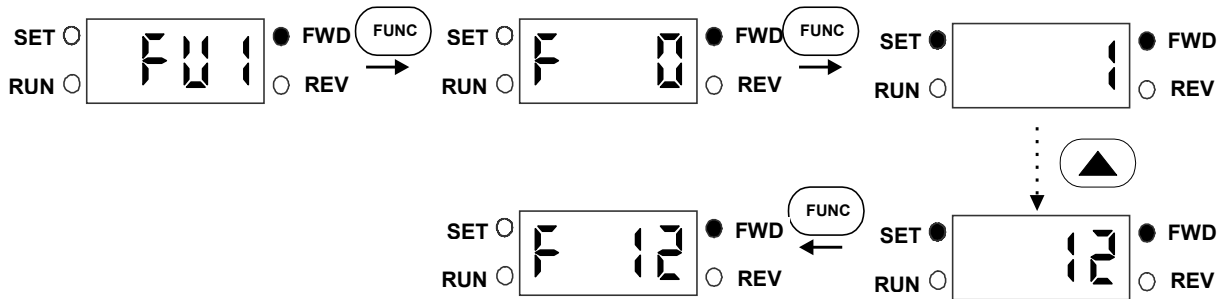

2.3 Parameter Group

The ACTIONMaster series offers a 7-segment (LED) keypad for the user. Parameters are separated into 4 function groups according to their application fields. The groups' names and the descriptions are as follows.

Group Name	Description
Drive group	Basic Parameters: Command Frequency, Accel/Decel Time, etc.
Function 1 group	Basic Parameters: Max. Frequency, Torque Boost, etc.
Function 2 Group	Application Parameters: Frequency Jump, Frequency Limit, etc.
Input/Output group	Multi-Function Terminal Setting and Sequence Operation Parameters

Refer to the parameter description in Chapter 4 for detailed description of each group.

■ Moving Through DRV Group Codes

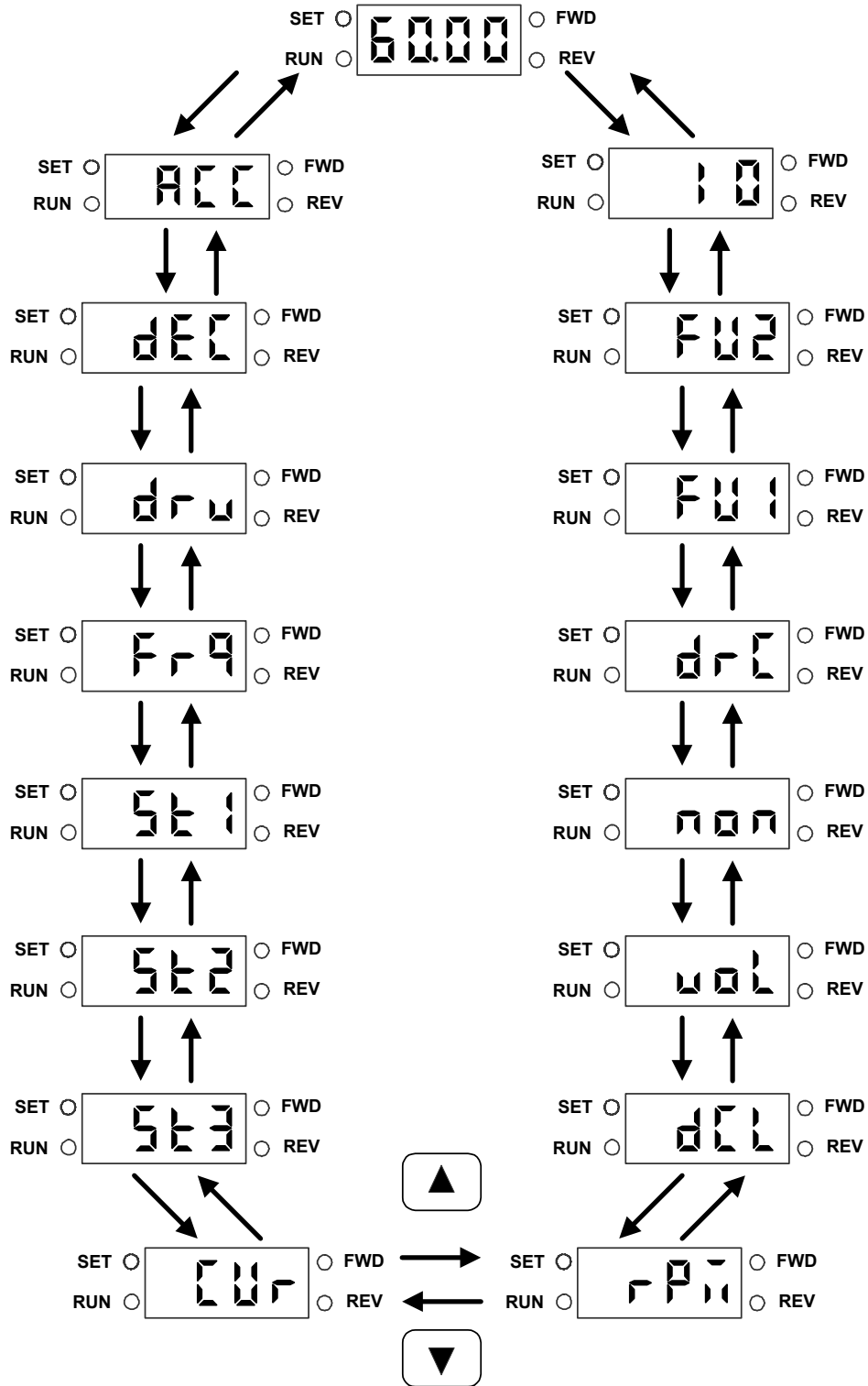

■ Moving Through Function Group Codes

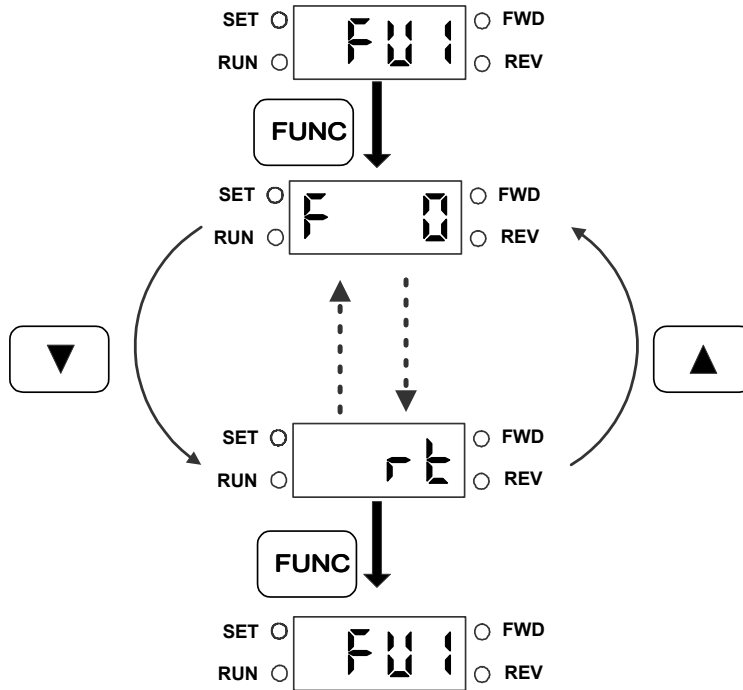

■ Moving Through I/O Group Codes

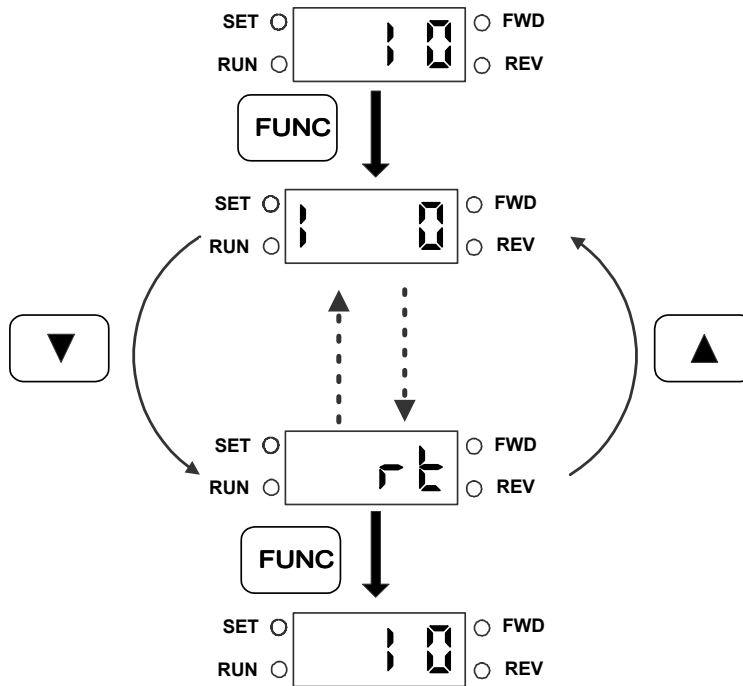

2.4 Operation

2.4.1 Operation From Keypad and Control Terminal

When the operation reference signal is given to the control terminal and the frequency setpoint is given by the keypad, set the DRV-03 (**drv**) to **1** (Fx/Rx-1), and set the DRV-04 (**Frq**) to **0** (Keypad-1). The frequency reference signal is set from the control terminal, and the forward, reverse, stop key of the keypad is invalid.

1. Turn the power ON and set the operation and the frequency parameters.
2. Set the DRV-03 (**drv**) to **1** (Fx/Rx-1), and the DRV-04 (**Frq**) to **0** (Keypad-1).
3. Turn ON the operation reference signal FX (or RX). Keypad LED (FWD key or REV key) will turn ON.
4. Set the operating frequency with the keypad. Use the FUNC, ▲ (Up), FUNC keys and set the frequency to 50.00Hz. The motor will rotate at 50Hz. The LED (RUN) of the keypad will blink when the inverter is accelerating or decelerating.
5. Turn the operation reference signal FX (or RX) OFF. The LED (FWD of REV) of the keypad will turn OFF.

Note: The user may also operate the inverter by setting the operation reference signal from the Keypad, and setting the frequency reference signal to the control terminal. (Set DRV-03 (**drv**) to **0** (Keypad), and the DRV-04 (**Frq**) to **2** (V1)).

2.4.2 Operation From Control Terminal

1. Turn the power ON and set the operation and the frequency reference to the control terminal mode.
2. Set the DRV-03 (**drv**) to **1** (Fx/Rx-1), and the DRV-04 (**Frq**) to **2** (V1).
3. Set the analog frequency reference by turning the potentiometer (frequency reference) slowly to the right. The keypad will display the output frequency (50.00 Hz).
4. Slowly turning the potentiometer (frequency reference) to the left will decrease the output frequency. The inverter will stop operating and the motor will come to a halt when the frequency reaches 0.00Hz.
5. Turn OFF the operation reference signal FX (or RX).

Note: FU1-20, FU1-21, FU1-25, FU1-36, FU2-54, FU2-83, I/O-05, I/O-10 are set at 50Hz for Standard (EU) types and 60Hz for US types.

2.4.3 Operation From Keypad

1. Turn the power ON and set the operation and frequency reference to 'keypad operating mode'.
2. Set the DRV-03 (drv) to 0 (Keypad), and the Frq [Frequency Reference Source Selection] to Keypad-1.
3. Use FUNC, ▲ (Up) key to set the operating frequency to 50.00Hz. When the inverter is not running the command frequency is displayed.
4. Press the RUN key. The motor will rotate and the keypad will display the output frequency.
5. Press the STOP/RESET key. The motor will decelerate and come to a halt, and the keypad will display the command frequency.

CHAPTER 3 - PARAMETER LIST

3.1 Drive Group [DRV]

Code	Description	Keypad Display	Setting Range	Units	Factory Default	Adj. During Run	Page
DRV-00	Output Frequency during running, Reference Frequency during stop	0.00	0.00 to (FU1-20)	0.01	00.00 [Hz]	Yes	34
DRV-01	Acceleration Time	ACC	0.0 to 999.9 [sec]	0.1	10.0 [sec]	Yes	34
DRV-02	Deceleration Time	DEC	0.0 to 999.9 [sec]	0.1	20.0 [sec]	Yes	34
DRV-03	Drive Mode (Run/Stop Method)	Drv	0 (keypad)	-	1 (Fx/Rx-1)	No	35
			1 (Fx/Rx-1)				
			2 (Fx/Rx-2)				
			3 (RS485)				
DRV-04	Frequency Mode (Freq. Setting Method)	Frq	0 [Keypad-1]	-	0 [Keypad-1]	No	35
			1 (Keypad-2)				
			2 (V1)				
			3 (I)				
			4 (V1+I)				
			5 (RS485)				
DRV-05	Step Frequency 1	St1	0.00 to (FU1-20)	0.01	10.00 [Hz]	Yes	36
DRV-06	Step Frequency 2	St2			20.00 [Hz]		
DRV-07	Step Frequency 3	St3			30.00 [Hz]		
DRV-08	Output Current	Cur	* [A]	-	- [A]	-	36
DRV-09	Motor Speed	RPM	* [rpm]	-	- [rpm]	-	36
DRV-10	DC link Voltage	DCL	* [V]	-	- [V]	-	37
DRV-11	User Display Selection	vOL, Por, tOr	Selected in FU2-73 (User disp)	-	-	-	37
DRV-12	Fault Display	nOn	-	-	None nOn	-	37
DRV-13	Motor Direction Set	drc	F (Forward)	-	F (Forward)	Yes	37
			r (Reverse)				
DRV-20	FU1 Group Selection	FU1					38
DRV-21	FU2 Group Selection	FU2					38
DRV-22	I/O Group Selection	I O					38

3.2 Function Group 1 [FU1]

Code	Description	Keypad Display	Setting Range	Units	Factory Default	Adj. During Run	Page
FU1-00	Jump to Desired Code #	F0	1 to 99	1	3	Yes	39
FU1-03	Run Prevention	F3	0 (None)	-	0 (None)	No	39
			1 (Forward Prev)				
			2 (Reverse Prev)				
FU1-05	Acceleration Pattern	F5	0 (Linear)	-	0 (Linear)	No	39
			1 (S-Curve)				
			2 (U-Curve)				
			3 (Minimum)				
			4 (Optimum)				
FU1-06	Deceleration Pattern	F6	0 (Linear)	-	0 (Linear)	No	39
			1 (S-Curve)				
			2 (U-Curve)				
			3 (Minimum)				
			4 (Optimum)				
FU1-07	Stop Mode	F7	0 (Decel)	-	0 (Decel)	No	40
			1 (DC-Brake)				
			2 (Free-Run)				
FU1-08 ⁷	DC Injection Braking Frequency	F8	(FU1-22) to 50/60 [Hz]	0.01	5.00 [Hz]	No	41
FU1-09	DC Injection Braking On-delay Time	F9	0 to 60 [sec]	0.01	0.10 [sec]	No	
FU1-10	DC Injection Braking Voltage	F10	0 to 200 [%]	1	50 [%]	No	
FU1-11	DC Injection Braking Time	F11	0 to 60 [sec]	0.1	1.0 [sec]	No	
FU1-12	Starting DC Injection Braking Voltage	F12	0 to 200 [%]	1	50 [%]	No	41
FU1-13	Starting DC Injection Braking Time	F13	0.0 to 60.0 [sec]	0.1	0.0 [sec]	No	42
FU1-20	Maximum Frequency	F20	40.00 to 400.00 [Hz]	0.01	50 / 60 [Hz]	No	
FU1-21	Base Frequency	F21	30.00 to (FU1-20)	0.01	50 / 60 [Hz]	No	
FU1-22	Starting Frequency	F22	0.10 to 10.00 [Hz]	0.01	0.10 [Hz]	No	
FU1-23	Frequency Limit Selection	F23	0 (No)	-	0 (No)	No	42
			1 (Yes)				
FU1-24 ⁸	Low Limit Frequency	F24	0.00 to (FU1-25)	0.01	0.00 [Hz]	No	
FU1-25	High Limit Frequency	F25	(FU1-24) to (FU1-20)	0.01	50 / 60 [Hz]	No	
FU1-26	Manual/Auto Torque Boost Selection	F26	0 (Manual)	-	0 (Manual)	No	43
			1 (Auto)				
FU1-27	Torque Boost in Forward Direction	F27	0.0 to 15.0 [%]	0.1	2.0 [%]	No	
FU1-28	Torque Boost in Reverse Direction	F28		0.1	2.0 [%]	No	

⁷ Code FU1-08 through FU1-11 appears only when FU1-07 is set to 'DC-brake'.

⁸ Code FU1-24 through FU1-25 appears only when FU1-23 is set to 'Yes'.

Chapter 3 - Parameter List

Code	Description	Keypad Display	Setting Range	Units	Factory Default	Adj. During Run	Page	
FU1-29	Volts/Hz Pattern	F29	0 (Linear)	-	0 (Linear)	No	44	
			1 (Square)					
			2 (User V/F)					
FU1-30 ⁹	User V/F – Frequency 1	F30	0.00 to (FU1-32)	0.01	15.00 [Hz]	No	44	
FU1-31	User V/F – Voltage 1	F31	0 to 100 [%]	1	25 [%]	No		
FU1-32	User V/F – Frequency 2	F32	(FU1-30) to (FU1-34)	0.01	30.00 [Hz]	No		
FU1-33	User V/F – Voltage 2	F33	0 to 100 [%]	1	50 [%]	No		
FU1-34	User V/F – Frequency 3	F34	(FU1-32) to (FU1-36)	0.01	45.00 [Hz]	No		
FU1-35	User V/F – Voltage 3	F35	0 to 100 [%]	1	75 [%]	No		
FU1-36	User V/F – Frequency 4	F36	(FU1-34) to (FU1-20)	0.01	50 / 60 [Hz]	No		
FU1-37	User V/F – Voltage 4	F37	0 to 100 [%]	1	100 [%]	No		
FU1-38	Output Voltage Adjustment	F38	40 to 110 [%]	0.1	100.0 [%]	No	45	
FU1-39	Energy Save Level	F39	0 to 30 [%]	1	0 [%]	Yes	45	
FU1-50	Electronic Thermal Selection	F50	0 (No)	-	0 (No)	Yes	46	
			1 (Yes)					
FU1-51 ¹⁰	Electronic Thermal Level for 1 Minute	F51	FU1-52 to 250 [%]	1	180 [%]	Yes		
FU1-52	Electronic Thermal Level for Continuous	F52	50 to FU1-51	1	120 [%]	Yes		
FU1-53	Electronic Thermal Characteristic Selection (Motor type)	F53	0 (Self-cool)	-	0 (Self-cool)	Yes		
			1 (Forced-cool)					
FU1-54	Overload Warning Level	F54	30 to 250 [%]	1	150 [%]	Yes		47
FU1-55	Overload Warning Hold Time	F55	0 to 30 [sec]	0.1	10.0 [sec]	Yes		
FU1-56	Overload Trip Selection	F56	0 (No)	-	1 (Yes)	Yes	47	
			1 (Yes)					
FU1-57 ¹¹	Overload Trip Level	F57	30 to 250 [%]	1	200 [%]	Yes		
FU1-58	Overload Trip Delay Time	F58	0 to 60 [sec]	1	60.0 [sec]	Yes		
FU1-59	Stall Prevention Mode Selection	F59	000 – 111 (bit set) Bit 0: during Accel. Bit 1: during Steady speed Bit 2: during Decel.	bit	000	No	48	
FU1-60	Stall Prevention Level	F60	30 to 250 [%]	1	200 [%]	No		
FU1-99	Return Code	rt		-	-	-	49	

⁹ Code FU1-30 through FU1-37 appears only when FU1-29 is set to 'User V/F'.

¹⁰ Code FU1-51 through FU1-53 appears only when FU1-50 is set to 'Yes'.

¹¹ Code FU1-57 through FU1-58 appears only when FU1-56 is set to 'Yes'.

3.3 Function Group 2 [FU2]

Code	Description	Keypad Display	Setting Range	Units	Factory Default	Adj. During Run	Page
FU2-00	Jump to Desired Code #	H 0	1 to 99	1	30	Yes	50
FU2-01	Previous Fault History 1	H 1		-	None nOn	-	50
FU2-02	Previous Fault History 2	H 2					
FU2-03	Previous Fault History 3	H 3					
FU2-04	Previous Fault History 4	H 4					
FU2-05	Previous Fault History 5	H 5					
FU2-06	Erase Fault History	H 6					
FU2-07	Dwell Frequency	H 7	0 to FU1-20	0.01	5.00 [Hz]	No	50
FU2-08	Dwell Time	H 8	0 to 10 [sec]	0.1	0.0 [sec]	No	
FU2-10	Frequency Jump Selection	H 10	0 (No) 1 (Yes)	-	0 (No)	No	51
FU2-11 ¹²	Jump Frequency 1 Low	H 11	0.00 to (FU2-12)	0.01	0.00 [Hz]	No	
FU2-12	Jump Frequency 1 High	H 12	(FU2-11) to (FU1-20)	0.01	0.00 [Hz]	No	
FU2-13	Jump Frequency 2 Low	H 13	0.00 to (FU2-14)	0.01	0.00 [Hz]	No	
FU2-14	Jump Frequency 2 High	H 14	(FU2-13) to (FU1-20)	0.01	0.00 [Hz]	No	
FU2-15	Jump Frequency 3 Low	H 15	0.00 to (FU2-16)	0.01	0.00 [Hz]	No	
FU2-16	Jump Frequency 3 High	H 16	(FU2-15) to (FU1-20)	0.01	0.00 [Hz]	No	
FU2-19	Input/Output Phase Loss Protection	H 19	00 – 11 (bit set) Bit 0: Output Phase Loss Protection Bit 1: Input Phase Loss Protection	-	00	Yes	51
FU2-20	Power ON Start Selection	H 20	0 (No) 1 (Yes)	-	0 (No)	Yes	52
FU2-21	Restart after Fault Reset	H 21	0 (No) 1 (Yes)	-	0 (No)	Yes	52
FU2-22	Speed Search Selection	H 22	0000 – 1111 (bit set) Bit 0: During Accel. Bit 1: After Fault reset Bit 2: After Instant Power Failure restart Bit 3: When FU2-20 is set to 1 (Yes).	-	0000	No	53
FU2-23	Current Limit Level During Speed Search	H 23	80 to 250 [%]	1	180 [%]	Yes	53

¹² Code FU2-11 through FU2-16 appears only when FU2-10 is set to 'Yes'.

Chapter 3 - Parameter List

Code	Description	Keypad Display	Setting Range	Units	Factory Default	Adj. During Run	Page
FU2-24	P Gain During Speed Search	H 24	0 to 9999	1	100	Yes	53
FU2-25	I Gain During speed search	H 25	0 to 9999	1	5000	Yes	53
FU2-26	Number of Auto Restart Attempt	H 26	0 to 10	1	0	Yes	54
FU2-27	Delay Time before Auto Restart	H 27	0 to 60 [sec]	0.1	1.0 [sec]	Yes	
FU2-30	Rated Motor Selection	H 30	0.4 (0.37kW) 0.8 (0.75kW) 1.5 (1.5kW) 2.2 (2.2kW) 3.7 (3.7kW) 4.0 (4.0kW)	-	13	No	54
FU2-31	Number of Motor Pole	H 31	2 to 12	1	4	No	54
FU2-32 ¹⁴	Rated Motor Slip	H 32	0 to 10 [Hz]	0.01	14	No	
FU2-33	Rated Motor Current in RMS	H 33	0.1 to 99.9 [A]	1		No	
FU2-34 ¹⁵	No Load Motor Current in RMS	H 34	0.1 to 99.9 [A]	1		No	
FU2-36	Motor Efficiency	H 36	50 to 100 [%]	1		No	
FU2-37	Load Inertia	H 37	0 to 2	1		0	
FU2-39	Carrier Frequency	H 39	1 to 10 [kHz]	1	3 [kHz]	Yes	55
FU2-40	Control Mode Selection	H 40	0 (V/F) 1 (Slip Compen) 2 (PID)	-	0 (V/F)	No	56
FU2-50 ¹⁶	PID Feedback Signal Selection	H 50	0 (I) 1 (V1)	-	1 0	No	56
FU2-51	P Gain for PID Control	H 51	0 to 9999	1	3000	Yes	
FU2-52	I Gain for PID Control	H 52	0 to 9999	1	300	Yes	
FU2-53	D Gain for PID Control	H 53	0 to 9999	1	0	Yes	
FU2-54	Limit Frequency for PID Control	H 54	0 to FU1-20	0.01	50 / 60 [Hz]	Yes	
FU2-70	Reference Frequency for Accel and Decel	H 70	0 (Max Freq) 1 (Delta Freq)	-	Max frq 0	No	57
FU2-71	Accel/Decel Time Scale	H 71	0 (0.01 sec) 1 (0.1 sec) 2 (1 sec)	-	1 (0.1 sec)	Yes	58
FU2-72	Power On Display	H 72	0 (Cmd. Freq) 1 (Acc. Time) 2 (Dec. Time)	1	0 (Cmd. Freq)	Yes	58

¹³ The rated motor is automatically set according to the inverter model number. If a different motor is used, set the correct motor parameters.

¹⁴ This value is automatically entered according to the rated motor set in FU2-30. If different, set the correct motor parameters.

¹⁵ Code FU2-32 and FU2-34 appear only when FU2-40 is set to 'Slip comp'.

¹⁶ Code FU2-50 through FU2-54 appears only when FU2-40 is set to 'PID'.

Code	Description	Keypad Display	Setting Range	Units	Factory Default	Adj. During Run	Page
			3 (Drv Mode)				
			4 (Freq Mode)				
			5 (Step Freq 1)				
			6 (Step Freq 2)				
			7 (Step Freq 3)				
			8 (Current)				
			9 (Speed)				
			10 (DC Link Vtg)				
			11 (User Display)				
			12 (Fault Display)				
			13 (Motor Direction)				
FU2-73	User Display Selection	H 73	0 (Voltage)	-	0 (Voltage)	Yes	58
			1 (Watt)				
			2 (Torque)				
FU2-74	Gain for Motor Speed Display	H 74	1 to 1000 [%]	1	100 [%]	Yes	58
FU2-75	DB (Dynamic Braking) Resistor Mode Selection	H 75	0 (None)	-	2 (Ext. DB-R)	Yes	59
			1 (None)				
			2 (Ext. DB-R)				
FU2-76	Duty of Dynamic Braking Resistor	H 76	0 to 30 [%]	1	10 [%]	Yes	59
FU2-79	Software Version	H 79	.	-	.	-	59
FU2-81¹⁷	2 nd Acceleration Time	H 81	0.0 to 999.9 [sec]	0.1	5.0 [sec]	Yes	59
FU2-82	2 nd Deceleration Time	H 82	0.0 to 999.9 [sec]	0.1	10.0 [sec]	Yes	
FU2-83	2 nd Base Frequency	H 83	30 to FU1-20	0.01	50 / 60 [Hz]	No	
FU2-84	2 nd V/F Pattern	H 84	0 (Linear)	-	0 (Linear)	No	
			1 (Square)				
			2 (User V/F)				
FU2-85	2 nd Forward Torque Boost	H 85	0 to 15 [%]	0.1	2.0 [%]	No	
FU2-86	2 nd Reverse Torque Boost	H 86	0 to 15 [%]	0.1	2.0 [%]	No	
FU2-87	2 nd Stall Prevention Level	H 87	30 to 250 [%]	1	200[%]	No	
FU2-88	2 nd Electronic Thermal Level for 1 Minute	H 88	FU2-89 to 250 [%]	1	180 [%]	Yes	
FU2-89	2 nd Electronic Thermal Level for Continuous	H 89	50 to (FU2-88)	1	120 [%]	Yes	
FU2-90	2 nd Rated Motor Current	H 90	0.1 to 99.9 [A]	0.1	- [A]	No	
FU2-91	Read Parameters into Keypad from Inverter	H 91	0 (No)	-	0 (No)	No	60
			1 (Yes)				
FU2-92	Write Parameters to Inverter from Keypad	H 92	0 (No)	-	0 (No)	No	
			1 (Yes)				

¹⁷ Code FU2-81 through FU2-90 appears only when one of I/O-12 ~ I/O-14 is set to '2nd function'.

Chapter 3 - Parameter List

Code	Description	Keypad Display	Setting Range	Units	Factory Default	Adj. During Run	Page
FU2-93	Initialize Parameters	H 93	0 (No)	-	0 (No)	No	60
			1 (All Groups)				
			2 (DRV)				
			3 (FU1)				
			4 (FU2)				
5 (I/O)							
FU2-94	Parameter Write Protection	H 94	0 to 255 ¹⁸	1	0	Yes	60
FU2-99	Return Code	rt		-	-	Yes	60

3.4 Input/Output Group [I/O]

Code	Description	Keypad Display	Setting Range	Units	Factory Default	Adj. During Run	Page
I/O-00	Jump to Desired Code #	I 0	1 to 99	1	1	Yes	62
I/O-01	Filtering Time Constant for V1 Signal Input	I 1	0 to 9999 [ms]	1	100 [ms]	Yes	62
I/O-02	V1 Input Minimum Voltage	I 2	0 to I/O-04	0.01	0.00 [V]	Yes	
I/O-03	Frequency corresponding to V1 Input Minimum Voltage	I 3	0 to FU1-20	0.01	0.00 [Hz]	Yes	
I/O-04	V1 Input Maximum Voltage	I 4	(I/O-02) to 12.00 [V]	0.01	10.00 [V]	Yes	
I/O-05	Frequency corresponding to V1 Input Maximum Voltage	I 5	0.00 to (FU1-20)	0.01	50 / 60 [Hz]	Yes	
I/O-06	Filtering Time Constant for I Signal Input	I 6	0 to 9,999 [ms]	1	100 [ms]	Yes	62
I/O-07	I Input Minimum Current	I 7	0.00 to (I/O-09)	0.01	4.00 [mA]	Yes	
I/O-08	Frequency corresponding to I Input Minimum Current	I 8	0.00 to (FU1-20)	0.01	0.00 [Hz]	Yes	
I/O-09	I Input Maximum Current	I 9	(I/O-07) to 24.00[mA]	0.01	20.00 [mA]	Yes	
I/O-10	Frequency corresponding to I Input Maximum Current	I 10	0.00 to (FU1-20)	0.01	50 /60 [Hz]	Yes	63
I/O-11	Criteria for Analog Input Signal Loss	I 11	0 (None)	-	0 (No)	Yes	
			1 (Half of x1)				
			2 (Below x1)				
I/O-12	Multi-function Input Terminal 'P1' Define	I 12	0 (Speed-L)	-	0 (Speed-L)	No	64
			1 (Speed-M)				
			2 (Speed-H)				

¹⁸ This function is used to lock the parameters from being changed. Keypad displays "U 0" when the parameters are unlocked and "L 0" when locked. The lock and unlock code is '12'.

Code	Description	Keypad Display	Setting Range	Units	Factory Default	Adj. During Run	Page
	8, 15, 17, 20, 21, 22, 23, 24, 25, 26 (-Reserved-)		3 (XCEL-L) 4 (XCEL-M) 5 (XCEL-H) 6 (Dc-brake) 7 (2nd Func) 9 (V1-Ext) 10 (Up) 11 (Down) 12 (3-Wire) 13 (Ext Trip-A) 14 (Ext Trip-B) 16 (Open-Loop) 18 (Analog Hold) 19 (XCEL Stop)				
I/O-13	Multi-function Input Terminal 'P2' Define	I 13	Same as above I/O-12	-	1 (Speed-M)	No	64
I/O-14	Multi-function Input Terminal 'P3' Define	I 14	Same as above I/O-12	-	2 (Speed-H)	No	
I/O-15	Terminal Input Status	I 15	00000000 – 11111111 (bit set)	-	00000000	-	67
I/O-16	Terminal Output Status	I 16	0 – 1 (bit set)	-	0	-	
I/O-17	Filtering Time Constant for Multi- function Input Terminals	I 17	2 to 50	1	2	Yes	67
I/O-20	Jog Frequency Setting	I 20	0.00 to (FU1-20)	0.01	10.00 [Hz]	Yes	67
I/O-21	Step Frequency 4	I 21	0.00 to (FU1-20)		40.00 [Hz]	Yes	
I/O-22	Step Frequency 5	I 22	0.00 to (FU1-20)		50.00 [Hz]	Yes	
I/O-23	Step Frequency 6	I 23	0.00 to (FU1-20)		40.00 [Hz]	Yes	
I/O-24	Step Frequency 7	I 24	0 .00 to (FU1-20)		30.00 [Hz]	Yes	
I/O-25	Acceleration Time 1 for Step Frequency	I 25	0.0 to 999.9 [sec]	0.1	20.0 [sec]	Yes	68
I/O-26	Deceleration Time 1 for Step Frequency	I 26	0.0 to 999.9 [sec]	0.1	20.0 [sec]	Yes	
I/O-27	Acceleration Time 2	I 27	0.0 to 999.9 [sec]	0.1	30.0 [sec]	Yes	
I/O-28	Deceleration Time 2	I 28	0.0 to 999.9 [sec]	0.1	30.0 [sec]	Yes	
I/O-29	Acceleration Time 3	I 29	0.0 to 999.9 [sec]	0.1	40.0 [sec]	Yes	
I/O-30	Deceleration Time 3	I 30	0.0 to 999.9 [sec]	0.1	40.0 [sec]	Yes	
I/O-31	Acceleration Time 4	I 31	0.0 to 999.9 [sec]	0.1	50.0 [sec]	Yes	
I/O-32	Deceleration Time 4	I 32	0.0 to 999.9 [sec]	0.1	50.0 [sec]	Yes	
I/O-33	Acceleration Time 5	I 33	0.0 to 999.9 [sec]	0.1	40.0 [sec]	Yes	
I/O-34	Deceleration Time 5	I 34	0.0 to 999.9 [sec]	0.1	40.0 [sec]	Yes	

Chapter 3 - Parameter List

Code	Description	Keypad Display	Setting Range	Units	Factory Default	Adj. During Run	Page
I/O-35	Acceleration Time 6	I35	0.0 to 999.9 [sec]	0.1	30.0 [sec]	Yes	
I/O-36	Deceleration Time 6	I36	0.0 to 999.9 [sec]	0.1	30.0 [sec]	Yes	
I/O-37	Acceleration Time 7	I37	0.0 to 999.9 [sec]	0.1	20.0 [sec]	Yes	
I/O-38	Deceleration Time 7	I38	0.0 to 999.9 [sec]	0.1	20.0 [sec]	Yes	
I/O-40	FM (Frequency Meter) Output Selection	I40	0 (Frequency)	-	0 (Frequency)	Yes	68
			1 (Current)				
			2 (Voltage)				
			3 (DC Link Vtg)				
I/O-41	FM Output Adjustment	I41	10 to 200 [%]	1	100 [%]	Yes	
I/O-42	Frequency Detection Level	I42	0 to FU1-20	0.01	30.00 [Hz]	Yes	69
I/O-43	Frequency Detection Bandwidth	I43	0 to FU1-20	0.01	10.00 [Hz]	Yes	
I/O-44	Multi-function Output Define (MO) 15, 16, 18, 19 (-Reserved-)	I44	0 (FDT-1)	-	12 (Run)	Yes	69
			1 (FDT-2)				
			2 (FDT-3)				
			3 (FDT-4)				
			4 (FDT-5)				
			5 (OL)				
			6 (IOL)				
			7 (Stall)				
			8 (OV)				
			9 (LV)				
			10 (OH)				
			11 (Lost Command)				
			12 (Run)				
			13 (Stop)				
14 (Steady)							
17 (Search)							
20 (Ready)							
I/O-45	Fault Output Relay Setting (30A, 30B, 30C)	I45	000 – 111 (bit set) Bit 0: LV Bit 1: All Trip Bit 2: Auto Retry	-	010	Yes	72
I/O-46	Inverter Number	I46	1 to 32	1	1	Yes	72
I/O-47	Baud Rate	I47	0 (1200 bps)	-	3 (9600 bps)	Yes	
			1 (2400 bps)				
			2 (4800 bps)				
			3 (9600 bps)				
4 (19200 bps)							
I/O-48	Operating selection at Loss of Freq. Reference	I48	0 (None)	-	0 (None)	Yes	73
			1 (Free Run)				

Code	Description	Keypad Display	Setting Range	Units	Factory Default	Adj. During Run	Page
			2 (Stop)				
I/O-49	Waiting Time after Loss of Freq. Reference	149	0.1 to 120.0 [sec]	0.1	1.0 [sec]	Yes	
I/O-50	Communication Protocol Selection	150	0 (CMC- Bus ASCII)	-	7 (Modbus-RTU)	Yes	73
			7 (Modbus-RTU)				
I/O-99	Return Code	rt		-	1	Yes	73

Note: Parameters that are set by a bit are ON (1) when the upper LED is lit as shown below. (F59, H19, H22, I15, I16, I45 are the parameters that are set by bit.)

Example) when the keypad displays '00000011'

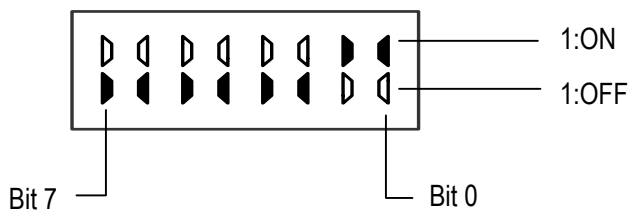

Note: FU1-20, FU1-21, FU1-25, FU1-36, FU2-54, FU2-83, I/O-05 and I/O-10 are set at 50Hz for Standard (EU) types and 60Hz for US types. Please check these parameters before commissioning to verify that you have the right product.

CHAPTER 4 - PARAMETER DESCRIPTION

4.1 Drive Group [DRV]

DRV-00: Output Frequency

50.00

This code gives information regarding motor direction set in DRV-13, and output or reference frequency.

You can set the command frequency by pressing [FUNC] key in this code.

Related Functions: DRV-04 [Freq Mode]
FU1-20 [Max Freq]
I/O-01 to I/O-10 [Analog Reference Inputs]

- DRV-04: Select the frequency setting method. [Keypad-1, Keypad-2, V1, I, V1+I, Modbus-RTU]
- FU1-20: Set the maximum frequency that the inverter can output.
- I/O-01 to I/O-10: Scaling the analog input signals (V1 and I) for frequency reference.

DRV-01: Acceleration Time

ACC

DRV-02: Deceleration Time

DEC

The inverter targets the FU2-70 [Ref. Freq. for Accel/Decel] when accelerating or decelerating. When the FU2-70 is set to “Maximum Frequency”, the acceleration time is the time taken by the motor to reach FU1-20 [Maximum Frequency] from 0 Hz. The deceleration time is the time taken by the motor to reach 0 Hz from FU1-20.

When the FU2-70 is set to ‘Delta Frequency’, the acceleration and deceleration time is the taken to reach a targeted frequency (instead the maximum frequency) from a frequency.

The acceleration and deceleration time can be changed to a preset transient time via multi-function inputs. By setting the multi-function inputs (P1, P2, P3) to ‘XCEL-L’, ‘XCEL-M’, ‘XCEL-H’ respectively, the Accel and Decel time set in I/O-25 to I/O-38 are applied according to the binary inputs of the P1, P2, P3.

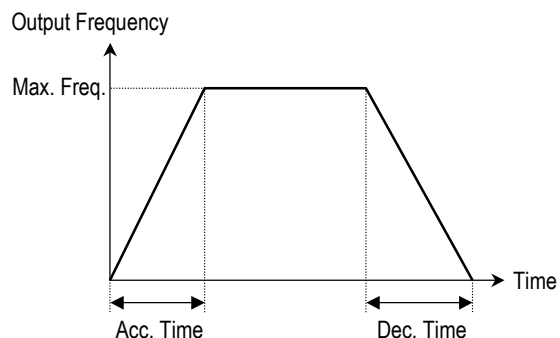

Related Functions: FU1-20 [Max Freq]
FU2-70 [Reference Freq. for Accel/Decel]
FU2-71 [Accel/Decel Time Scale]
I/O-12 to I/O-14 [Multi-Function Input Terminal P1, P2, P3]
I/O-25 to I/O-38 [Acc/Dec Time for Step Frequency]

- FU2-70: Select the frequency to be targeted for acceleration and deceleration. [Max Freq, Delta Freq]
- FU2-71: Select the time scale. [0.01, 0.2, 1]
- I/O-12 to I/O-14: Set the terminal function of P1, P2, P3 terminal inputs.
- I/O-25 to I/O-38: Preset the Accel/Decel time activated via multifunction inputs (P1, P2, P3)

DRV-03: Drive Mode (Run/stop Method)

drv

Select the source of Run/Stop command.

Setting Range		Description
Select	Display	
Keypad	0	Run/stop is controlled by Keypad.
Fx/Rx-1	1	Control Terminals FX, RX and CM control Run/Stop. (Method 1)
Fx/Rx-2	2	Control Terminals FX, RX and CM control Run/Stop. (Method 2)
MODBUS-RTU	3	Run/stop is controlled by Serial Communication (MODBUS-RTU) Refer to Chapter 5.

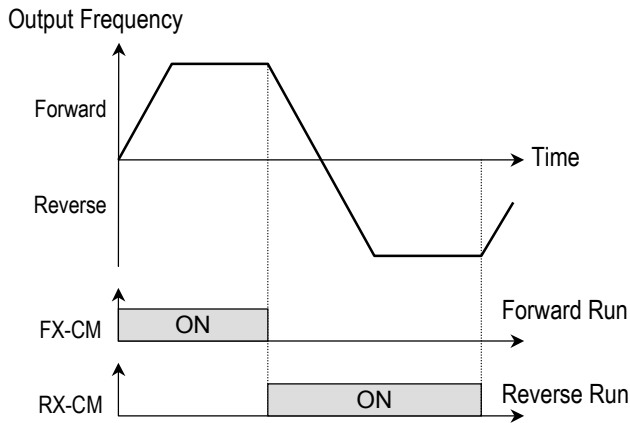

[Drive Mode: 'Fx/Rx-1']

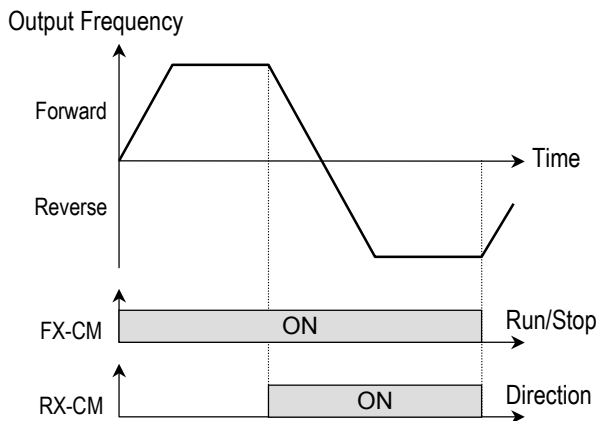

[Drive Mode: 'Fx/Rx-2']

DRV-04: Frequency Mode (Frequency Setting Method)

F r q

Select the source of frequency setting.

Setting Range		Description
Select	Display	
Keypad-1	0	Frequency is set at DRV-00. The frequency is changed by pressing [FUNC] key and entered by pressing [FUNC] key. The inverter does not output the changed frequency until the [FUNC] key is pressed.
Keypad-2	1	Frequency is set at DRV-00. Press [FUNC] key and then by pressing the [▲], [▼] key, the inverter immediately outputs the changed frequency. Pressing the [FUNC] key saves the changed frequency.
V1	2	Input the frequency reference (0-10V) to the "V1" control terminal. Refer to the I/O-01 to I/O-05 for scaling the signal.
I	3	Input the frequency reference (4~20mA) to the "I" control terminal. Refer to the I/O-06 to I/O-10 for scaling the signal.
V1+I	4	Input the frequency reference (0~10V, 4~20mA) to the "V1", "I" control terminals. The 'V1' signal overrides the 'I' signal.
MODBUS-RTU	5	Frequency is set by Serial Communication (MODBUS-RTU) Refer to Chapter 5.

Related Functions: I/O-01 to I/O-10 [Reference Inputs]
 ■ I/O-01 to I/O-10: Scaling analog input signals (V1 and I) for frequency reference.

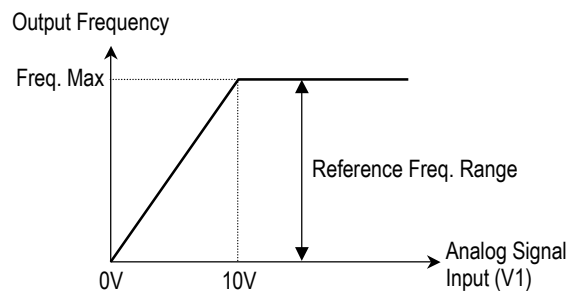

[Freq Mode: 'V1']

Chapter 4 - Parameter Description [DRV]

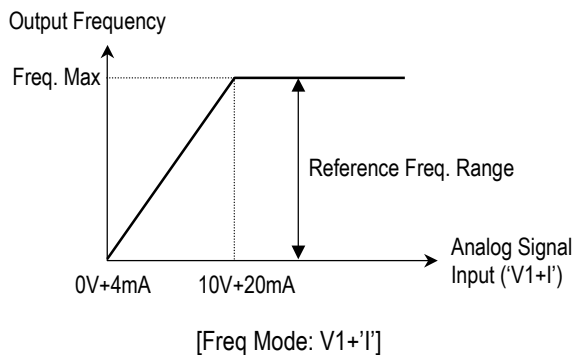
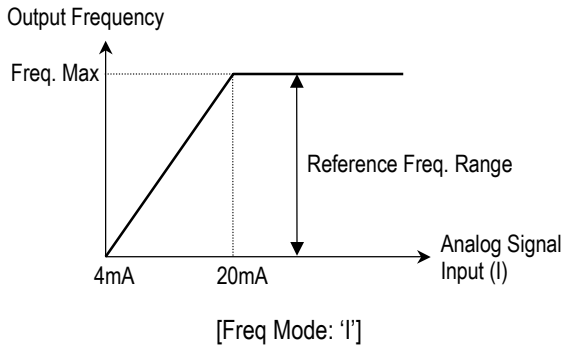

DRV-05 ~ DRV-07: Step Frequency 1 ~ 3

St1

St2

St3

The inverter outputs preset frequencies set in these codes according to the multi-function input terminals configured as 'Speed-L', 'Speed-M' and 'Speed-H'. The output frequencies are determined by the binary combination of P1, P2, P3 configured in I/O-12 to I/O-17. Refer to the following table for the preset frequency outputs.

Speed 4 through Speed 7 is set in I/O-21~I/O-24.

Binary Combination of P1, P2, P3			Output Frequency	Step Speed
Speed-L	Speed-M	Speed-H		
0	0	0	DRV-00	Speed 0
1	0	0	DRV-05	Speed 1
0	1	0	DRV-06	Speed 2
1	1	0	DRV-07	Speed 3

0: ON, 1: OFF

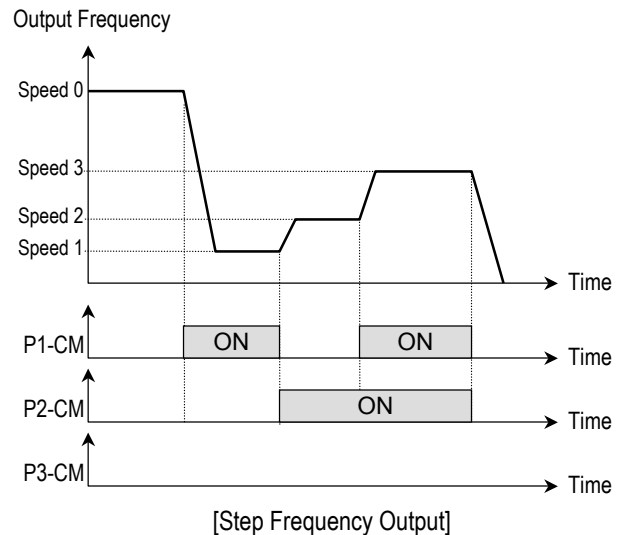

Related Functions: I/O-12 to I/O-14 [Reference Inputs]
I/O-17 [Filtering Time Constant]

- I/O-12 to I/O-14: Set the terminal function of P1, P2, P3 terminal inputs.
- I/O-17: Adjust response sensibility of input terminal to eliminate contact noise.

DRV-08: Output Current

Cur

This code displays the output current of the inverter in RMS.

DRV-09: Motor Speed

rPn

This code display the motor speed in RPM during the motor is running.

Use the following equation to scale the mechanical speed using FU2-74 [Gain for Motor Speed display] if you want to change the motor speed display to rotation speed (r/min) or mechanical speed (m/min).

$$\text{Motor Speed} = 120 * (F/P) * \text{FU2-74}$$

Where, F: output frequency and P: the number of motor poles

DRV-10: DC Link Voltage

This code displays the DC link voltage inside the inverter.

DRV-11: User Display Selection

This code display the parameter selected in FU2-73 [User Display]. There are 3 types of parameters in FU2-73 (Voltage, Watt and Torque).

DRV-12: Fault Display

This code displays the current fault (trip) status of the inverter. Use the [FUNC], [▲] and [▼] key to check for fault content(s), output frequency, output current, or whether the inverter was accelerating, decelerating, or in constant speed at the time the fault occurred. Press the [FUNC] key to exit. The fault content will be stored in FU2-01

to FU2-05 when the [RESET] key is pressed.

[Fault Contents]

Fault (Trip)	Keypad Display
	Display
Over-Current	OC
Over-Voltage	OV
Emergency Stop (Not latched)	BX
Low-Voltage	LV
Overheat on Heat Sink	OH
Electronic Thermal Trip	ETH
Overload Trip	OLT
Inverter H/W Fault - EEP Error - FAN Lock - CPU Error - Ground Fault - NTC Wire Trouble	HW
Output Phase Loss	OPO
Inverter Overload	IOLT
Input Phase Open	COL

☞ **Note:** The inverter will not reset when H/W fault occurs. Repair the fault before turning on the power.

☞ **Note:** When multiple faults occur, only the highest-level fault will be displayed.

Related Functions: FU2-01 to FU2-05 [Previous Fault History]
FU2-06 [Erase Fault History]
■ FU2-01 to FU2-05: Up to 5 faults are saved.
■ FU2-06: Erases faults saved in FU2-01 to FU2-05.

DRV-13: Motor Direction Set

This code sets the motor direction.

Display	Description
F	Run Forward Direction
r	Run Reverse Direction

DRV-20: FU1 Group selection



FU1

DRV-21: FU2 Group selection



FU2

DRV-22: I/O Group selection



I/O

Select the desired group and press the [FUNC] key to move to the desired group. The parameter in the group may be read or written after moving to the desired group.

4.2 Function 1 Group [FU1]

FU1-00: Jump to Desired Code

F 0

Jumping directly to any parameter code can be accomplished by entering the desired code number.

FU1-03: Run Prevention

F 3

This function prevents reverse operation of the motor. This function may be used for loads that rotate only in one direction such as fans and pumps.

Setting Range		Description
Select	Display	
None	0	Forward and reverse run is available.
Forward Prevention	1	Forward run is prevented.
Reverse Prevention	2	Reverse run is prevented.

FU1-05: Acceleration Pattern FU1-06: Deceleration Pattern

F 5

F 6

Different combinations of acceleration and deceleration patterns can be selected according to your application.

Setting Range		Description
Select	Display	
Linear	0	This is a general pattern for constant torque applications.
S-Curve	1	This pattern allows the motor to accelerate and decelerate smoothly. The actual acceleration and deceleration time takes longer- about 40% than the time set in DRV-01 and DRV-02. This setting prevents shock during acceleration and deceleration, and prevents objects from swinging on conveyors or other moving equipment.
U-Curve	2	This pattern provides more efficient control of acceleration and deceleration in typical winding machine applications.
Minimum	3	The inverter makes shorten the acceleration time by accelerating with a current rate of about 150% of its rated current and reduces the deceleration time by decelerating with a DC voltage rate of 95% of its over-voltage trip level. <i>Appropriate application:</i> When the maximum capability of the inverter and the motor are required. <i>Inappropriate application:</i> The current limit function may operate for a long period of time for loads that have high inertia such as fans.
Optimum	4	The inverter accelerates with a current rate of about 120% of its rated current and decelerates with a DC voltage rate of 93% of its over-voltage trip level.

- ☞ **Note:** In case of selecting the 'Minimum' or 'Optimum', the DRV-01 [Accel Time] and DRV-02 [Decel Time] is ignored.
- ☞ **Note:** 'Minimum' and 'Optimum' functions operate normally when the load inertia is less than 10 times compared to the motor inertia. (FU2-37)
- ☞ **Note:** 'Optimum' is useful when the motor capacity is smaller than the inverter capacity.
- ☞ **Note:** 'Minimum' and 'Optimum' functions are not appropriate for down operation in an elevator application.

Chapter 4 - Parameter Description [FU1]

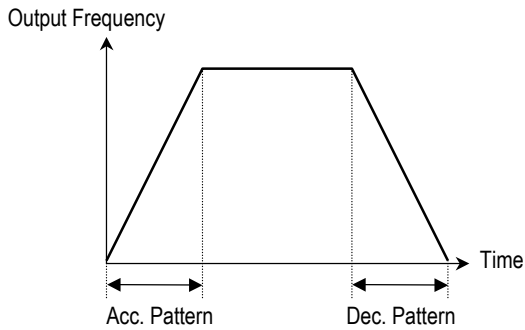

[Accel/Decel Pattern: 'Linear']

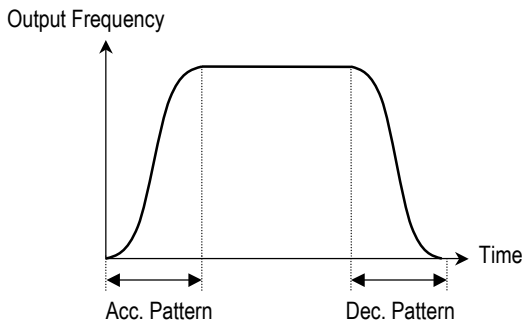

[Accel/Decel Pattern: 'S-Curve']

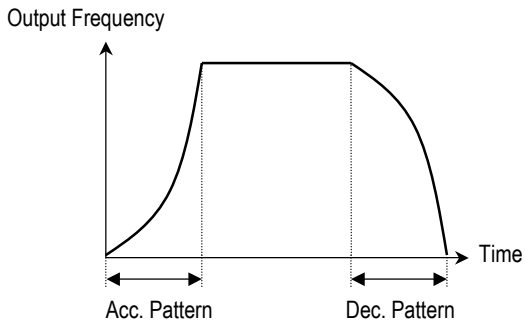

[Accel/Decel Pattern: 'U-Curve']

FU1-07: Stop Mode



Selects the stopping method for the inverter.

Setting Range		Description
Select	Display	
Decel	0	Inverter stops by the deceleration pattern.
DC-Brake	1	Inverter stops with DC injection braking. Inverter outputs DC voltage when the frequency reached the DC injection braking frequency set in FU1-08 during decelerating.
Free-Run (Coast to stop)	2	Inverter cuts off its output immediately when the stop signal is entered.

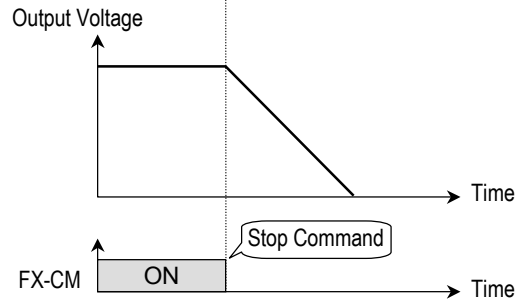
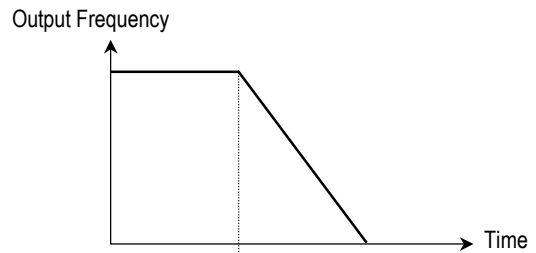

[Stop Mode: 'Decel']

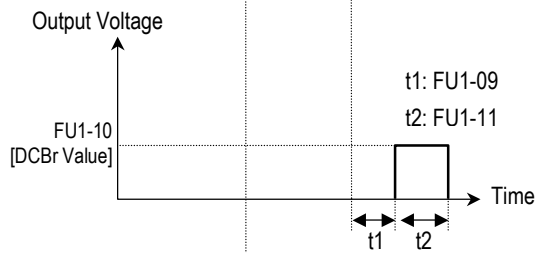
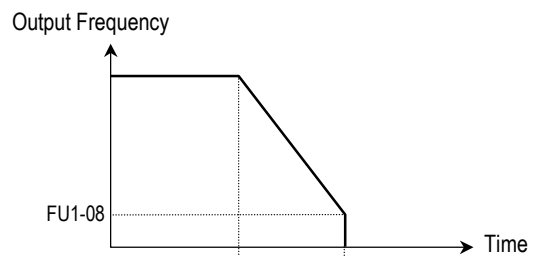

[Stop Mode: 'DC-Brake']

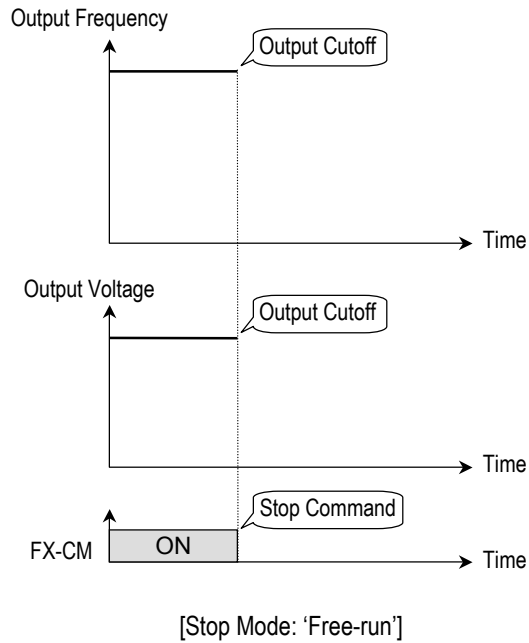

FU1-08: DC Injection Braking Frequency
FU1-09: DC Injection Braking On-delay Time
FU1-10: DC Injection Braking Voltage
FU1-11: DC Injection Braking Time

F 8
 F 9
 F 10
 F 11

This function stops the motor immediately by introducing DC voltage to the motor windings. Selecting 'DC-Brake' in FU1-07 activates FU1-08 through FU1-11.

FU1-08 [DC Injection Braking Frequency] is the frequency at which the inverter starts to output DC voltage during deceleration.

FU1-09 [DC Injection Braking On-delay Time] is the inverter output blocking time before DC injection braking.
FU1-10 [DC Injection Braking Voltage] is the DC voltage applied to the motor and is based on FU2-33 [Rated Current of Motor].
FU1-11 [DC Injection Braking Time] is the time the DC current is applied to the motor.

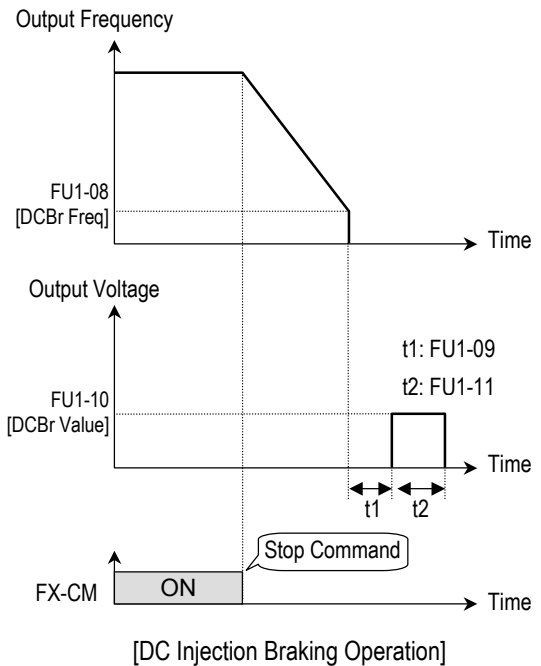

FU1-12: Starting DC Injection Braking Voltage
FU1-13: Starting DC Injection Braking Time

F 12
 F 13

Inverter holds the starting frequency for Starting DC Injection Braking Time. The inverter outputs DC voltage to the motor for FU1-13 [Starting DC Injection Braking Time] with the FU1-12 [Starting DC Injection Braking Voltage] before accelerating.

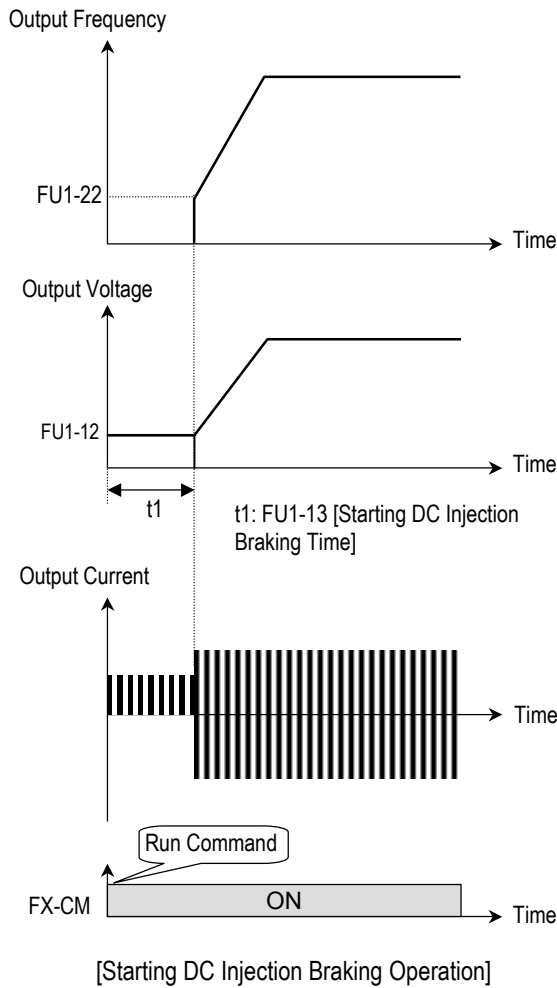

Related Functions: FU2-33 [Rated Current of Motor]
 ■ FU2-33: The DC current is limited by this parameter.

- ☞ **Note:** The DC injection braking parameter does not function when either FU1-12 or FU1-13 is set to "0".
- ☞ **Note:** FU1-12 [Starting DC Injection Braking Voltage] is also used as the DC Injection Braking Voltage for the multifunction input when the multifunction input is set to "DC Braking".

FU1-20: Maximum Frequency
FU1-21: Base Frequency
FU1-22: Starting Frequency

F 20

F 21

F 22

FU1-20 [Maximum Frequency] is the maximum output frequency of the inverter. Make sure this maximum frequency does not exceed the rated speed of motor.

FU1-21 [Base Frequency] is the frequency where the inverter outputs its rated voltage. In case of using a 50Hz motor, set this to 50Hz.

FU1-22 [Starting Frequency] is the frequency where the inverter starts to output its voltage.

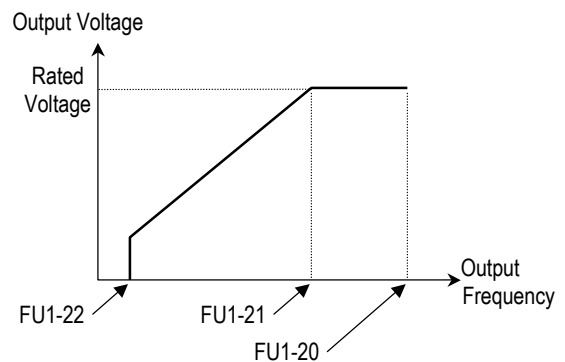

☞ **Note:** If the command frequency set point is set lower than the starting frequency, inverter will not output voltage.

FU1-23: Frequency Limit Selection
FU1-24: Low Limit Frequency
FU1-25: High Limit Frequency

F 23

F 24

F 25

FU1-23 selects the limits for the inverter operating frequency. If FU1-23 is set to 'Yes', inverter operates within the upper and lower limit setting. The inverter operates at the upper or the lower limit when the frequency reference is outside the frequency limit range.

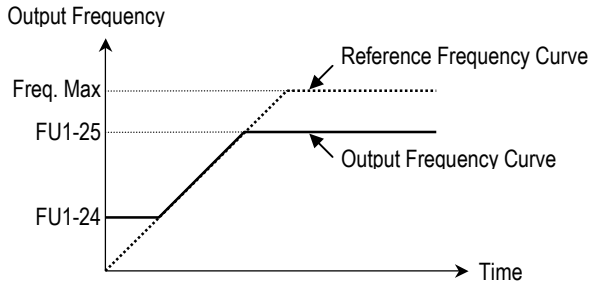

[Freq. limit: 'Yes']

Note: Frequency limit does not work during acceleration and deceleration.

FU1-26: Manual/Auto Boost Selection
FU1-27: Torque Boost in Forward Direction
FU1-28: Torque Boost in Reverse Direction

F 26

F 27

F 28

This function is used to increase the starting torque at low speed by increasing the output voltage of the inverter. If the boost value is set higher than required, it may cause the motor flux to saturate, causing over-current trip. Increase the boost value when there is excessive distance between inverter and motor.

[Manual Torque Boost]: The forward and reverse torque boost is set separately in FU1-27

and FU1-28.

Note: The torque boost value is the percentage of inverter rated voltage.

Note: When FU1-29 [Volts/Hz Pattern] is set to 'User V/F', this function does not work.

[Auto Torque Boost]: Inverter outputs high starting torque by automatically boosting according to the load.

Note: Auto torque boost is only available for the 1st motor. For multiple motors, manual torque boost must be used.

Note: The auto torque boost value is added to the manual torque boost value.

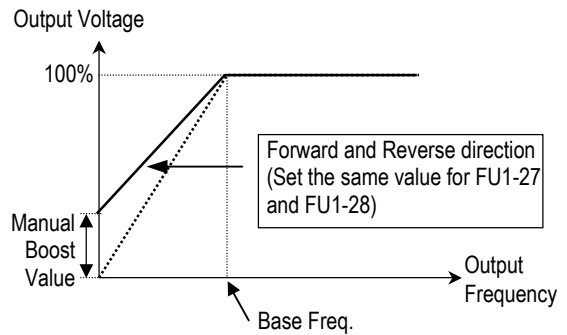

[Constant Torque Loads: Conveyor, Moving Equip. etc.]

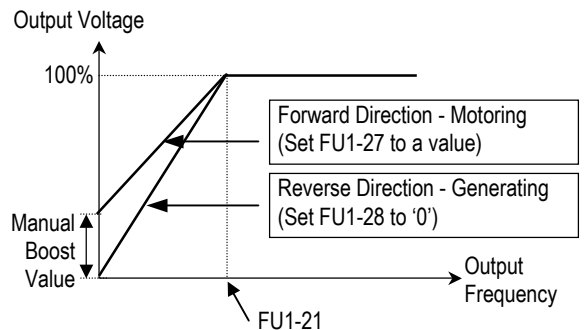

[Ascending and Descending Loads: Parking, Hoist etc.]

Related Functions: FU1-29 [V/F Pattern]

FU1-29: Volts/Hz Pattern

F 29

This is the pattern of voltage/frequency ratio. Select the proper V/F pattern according to the load. The motor torque is dependent on this V/F pattern.

[Linear] pattern is used where constant torque is required. This pattern maintains a linear volts/frequency ratio from zero to base frequency. This pattern is appropriate for constant torque applications.

[Square] pattern is used where variable torque is required. This pattern maintains squared volts/hertz ratio. This pattern is appropriate for fans, pumps, etc.

[User V/F] pattern is used for special applications. Users can adjust the volts/frequency ratio according to the application. This is accomplished by setting the voltage and frequency, respectively, at four points between starting frequency and base frequency. The four points of voltage and frequency are set in FU1-30 through FU1-37.

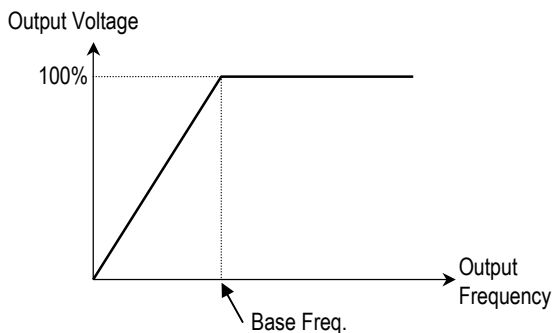

[V/F Pattern: 'Linear']

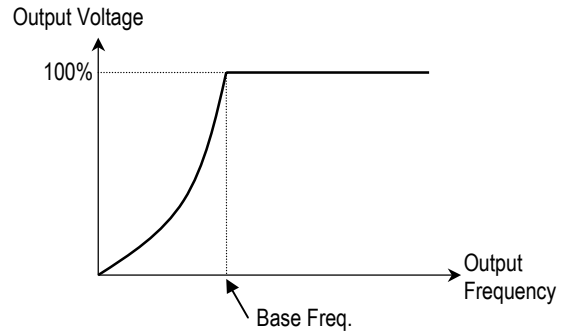

[V/F Pattern: 'Square']

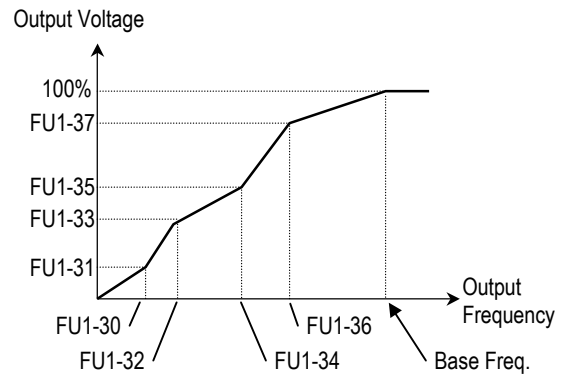

[V/F Pattern: 'User V/F']

FU1-30 ~ FU1-37: User V/F Frequency and Voltage

F 30

F 31

F 32

F 33

F 34

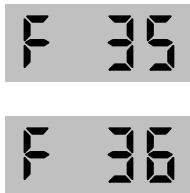

These functions are available only when 'User V/F' is selected in FU1-29 [V/F Pattern]. Users can make the custom V/F pattern by setting four points between FU1-22 [Starting Frequency] and FU1-21 [Base Frequency].

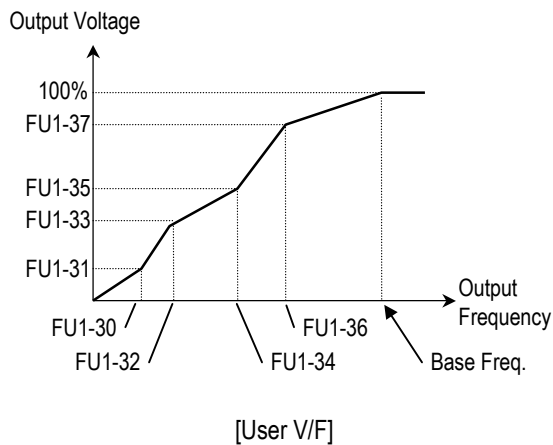

Note: When the 'User V/F' is selected, the torque boost of FU1-26 through FU1-28 is ignored.

FU1-38: Output Voltage Adjustment



This function is used to adjust the output voltage of the inverter. This is useful when using a motor that has a lower rated voltage than the main input voltage. When this is set at 100%, inverter outputs its rated voltage.

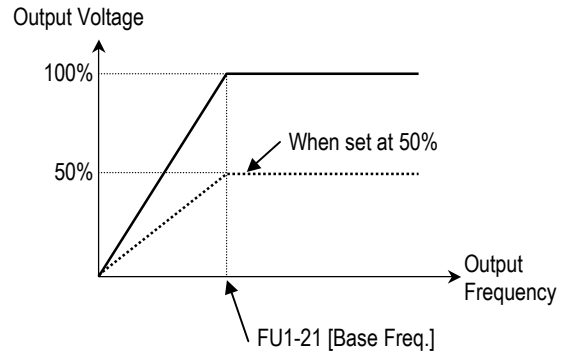

Note: The inverter output voltage does not exceed the main input voltage, even though FU1-38 is set at 110%.

FU1-39: Energy Save Level



This function is used to reduce the output voltage in applications that do not require high torque and current at its steady speed. The inverter reduces its output voltage after accelerating to the reference frequency (steady speed). This function may cause over-current trip due to the lack of output torque in a fluctuating load. This function does not work with 0% set point value.

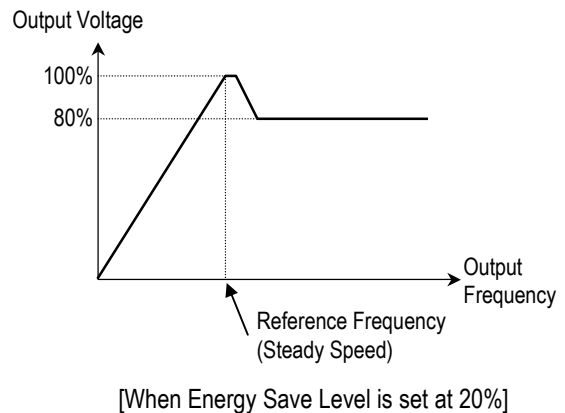

Note: This function is not recommended for a large load or for an application that need frequent acceleration and deceleration.

FU1-50: Electronic Thermal (Motor i^2t) Selection
FU1-51: Electronic Thermal Level for 1 Minute
FU1-52: Electronic Thermal Level for Continuous
FU1-53: Electronic Thermal Characteristic (Motor type) Selection

These functions are to protect the motor from overheating without using additional thermal overload relay. Inverter calculates the temperature rise of the motor using several parameters and determines whether or not the motor is overheating. Inverter will turn off its output and display a trip message when the electronic thermal feature is activated.

F 50

This function activates the ETH parameters by setting 'Yes'.

F 51

This is the reference current when the inverter determines the motor has overheated. Inverter trips in 1 minute when 150% of rated motor current established in FU2-33 flows for 1 minute.

Note: The set value is the percentage of FU2-33 [Rated Motor Current].

F 52

This is the current at which the motor can run continuously. Generally, this value is set to '100%' and which means the rated motor current set in FU2-33. This value must be set less than FU1-51 [ETH 1min].

Note: The set value is the percentage of FU2-33 [Rated Motor Current].

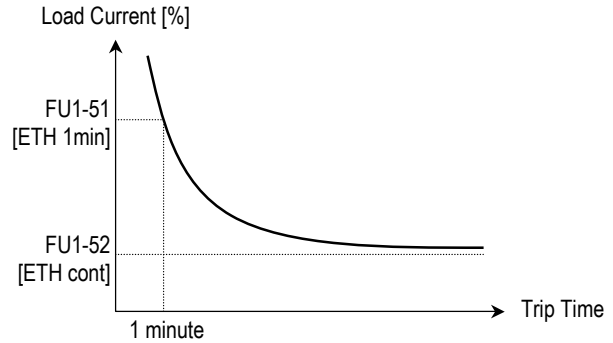

[Motor i^2t Characteristic Curve]

F 53

To make the ETH function (Motor i^2t) work correctly, the motor cooling method must be selected correctly according to the motor.

[Self-cool] is a motor that has a cooling fan connected directly to the shaft of the motor. Cooling effects of a self-cooled motor decrease when a motor is running at low speeds. The motor current is derated as the motor speed decreases.

[Forced-cool] is a motor that uses a separate motor to power a cooling fan. As the motor speed changes, the cooling effect does not change.

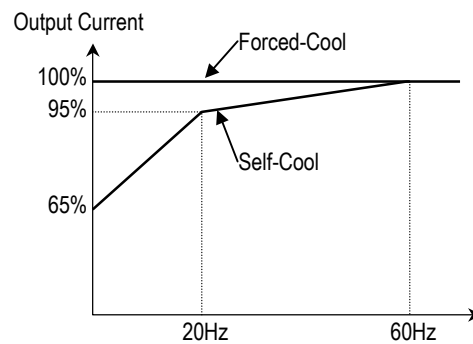

[Load Current Derating Curve]

Note: Despite the motor current changing frequently due to load fluctuation or acceleration and deceleration, the inverter calculates the i^2t and accumulates the value to protect the motor.

Related Functions: FU2-33 [Rated Motor Current]

FU1-54: Overload Warning Level
FU1-55: Overload Warning Time



The inverter generates an alarm signal when the output current has reached the FU1-54 [Overload Warning Level] for the FU1-55 [Overload Warning Time]. The alarm signal persists for the FU1-55 even if the current has become the level below the FU1-54.

Multi-function output terminal (MO-MG) is used as the alarm signal output. To output the alarm signal, set I/O 44 [Multifunction Output] to 'OL'.

- ☞ **Note:** Inverter is not tripped by this function.
- ☞ **Note:** The set value is the percentage of FU2-33 [Rated Motor Current].

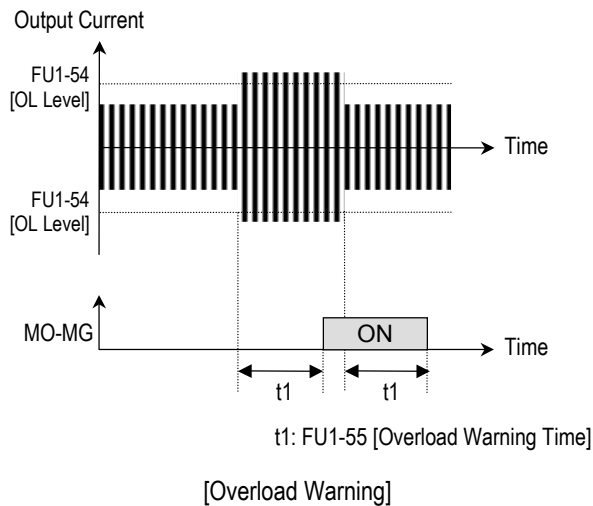

Related Functions: FU2-33 [Rated Motor Current]
 I/O-44 [Multi-function Output]

FU1-56: Overload Trip Selection
FU1-57: Overload Trip Level
FU1-58: Overload Trip Delay Time



Inverter cuts off its output and displays fault message when the output current persists over the FU1-57 [Overload Trip Level] for the time of FU1-58 [Overload Trip Time]. This function protects the inverter and motor from abnormal load conditions.

- ☞ **Note:** The set value is the percentage of FU2-33 [Rated Motor Current].

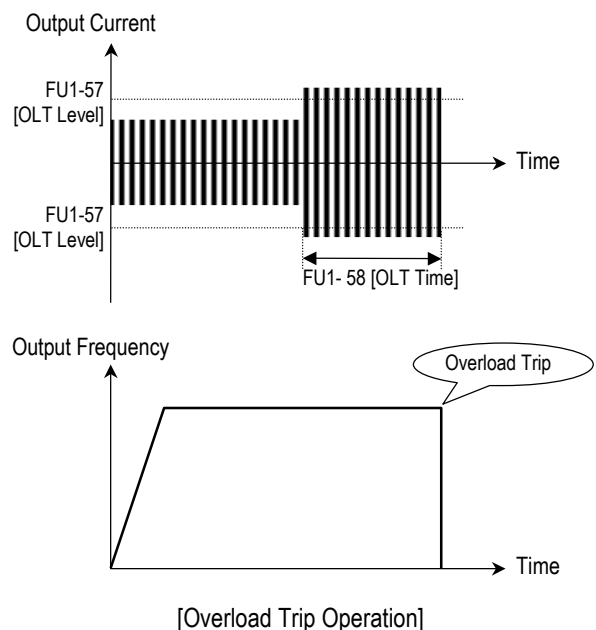

Related Functions: FU2-33 [Rated Motor Current]

FU1-59: Stall Prevention Mode Selection (Bit set)
FU1-60: Stall Prevention Level



This bit set parameter follows the conventions used in I/O-15 and I/O-16 to show the ON (bit set) status.



This function is used to prevent the motor from stalling by reducing the inverter output frequency until the motor current decreases below the stall prevention level. This function can be selected for each mode of acceleration, steady speed, and deceleration via bit combination.

Note: The set value is the percentage of FU2-33 [Rated Motor Current].

FU1-59 [Stall Prevention Mode Selection]

Setting Range			FU1-59	Description
3 rd bit	2 nd bit	1 st bit		
0	0	1	001	Stall Prevention during Acceleration
0	1	0	010	Stall Prevention during Steady Speed
1	0	0	100	Stall Prevention during Deceleration

When FU1-59 is set to '111', stall prevention works during accelerating, steady speed and decelerating.

Note: The acceleration and deceleration time may take longer than the time set in DRV-01, DRV-02 when Stall Prevention is selected.

Note: If stall prevention status persists, inverter may stop during acceleration.

Related Functions: FU2-33 [Rated Motor Current]

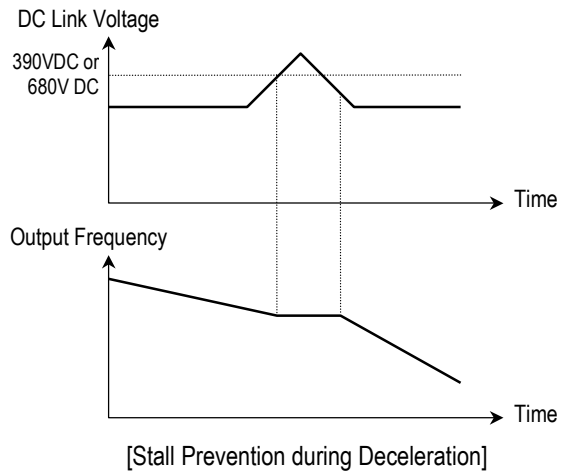
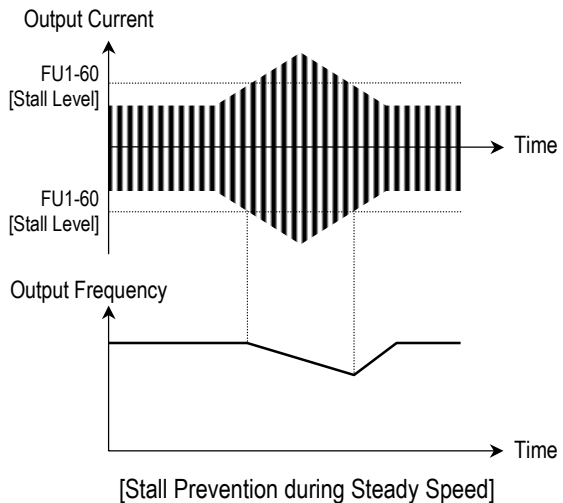
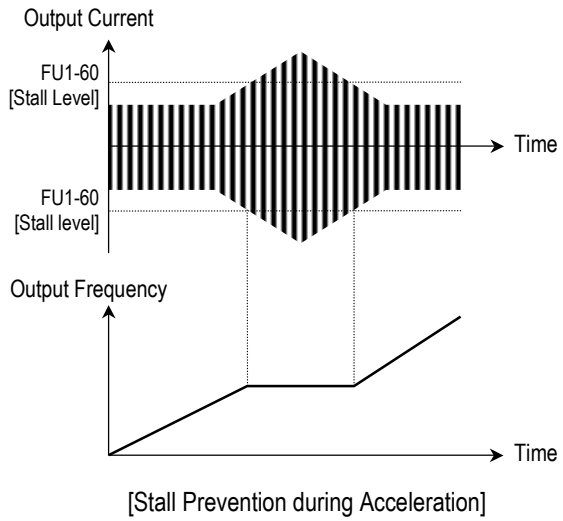

FU1-99: Return Code



This code is used to exit a group. Press [FUNC] key to exit.

Related Functions: FU2-99 [Return Code]
I/O-99 [Return Code]

4.3 Function 2 Group [FU2]

FU2-00: Jump to Desired Code



Jumping directly to any parameter code can be accomplished by entering the desired code number.

- FU2-01: Previous Fault History 1
- FU2-02: Previous Fault History 2
- FU2-03: Previous Fault History 3
- FU2-04: Previous Fault History 4
- FU2-05: Previous Fault History 5
- FU2-06: Erase Fault History



This code displays up to five previous fault (trip) status of the inverter. Use the [FUNC], [▲] and [▼] key before pressing the [RESET] key to check the fault content(s), output frequency, output current, and whether the inverter was accelerating, decelerating, or in constant speed at the time of the fault occurred. Press the [FUNC] key to exit. The fault content will be stored in FU2-01 through FU2-05 when the [RESET] key is pressed. For more detail, please refer to Chapter 7.

[Fault Contents]

Fault (Trip)	Keypad Display
Over-Current 1	OC
Over-Voltage	OV
Emergency Stop (Not Latched)	BX
Low-Voltage	LV
Ground Fault	GF
Over-Heat on Heat sink	OH
Electronic Thermal Trip	ETH
Over-Load Trip	OLT
Inverter H/W Fault	HW
Output Phase Loss	OPO
Input Phase Loss	COL
Inverter Over-Load	IOLT

☞ **Note:** There is Fan error, EEP error, CPU2 error, Ground fault and NTC error for the inverter Hardware Fault. The inverter will not reset when H/W fault occurs. Repair the fault before turning on the power.

☞ **Note:** When multiple faults occur, only the highest-level fault will be displayed.

Related Functions: DRV-12 [Fault Display] displays current fault status.



This function erases all fault histories of FU2-01 to FU2-05 from the memory.

FU2-07: Dwell Frequency FU2-08: Dwell Time



This function is used to output torque in an intended direction. It is useful in hoisting applications to get enough torque before a

releasing mechanical brake. If the dwell time is set at '0', this function is not available. In dwell operation, the inverter outputs AC voltage not a DC voltage.

Note: DC Injection Braking does not output torque to an intended direction. It is just to hold the motor.

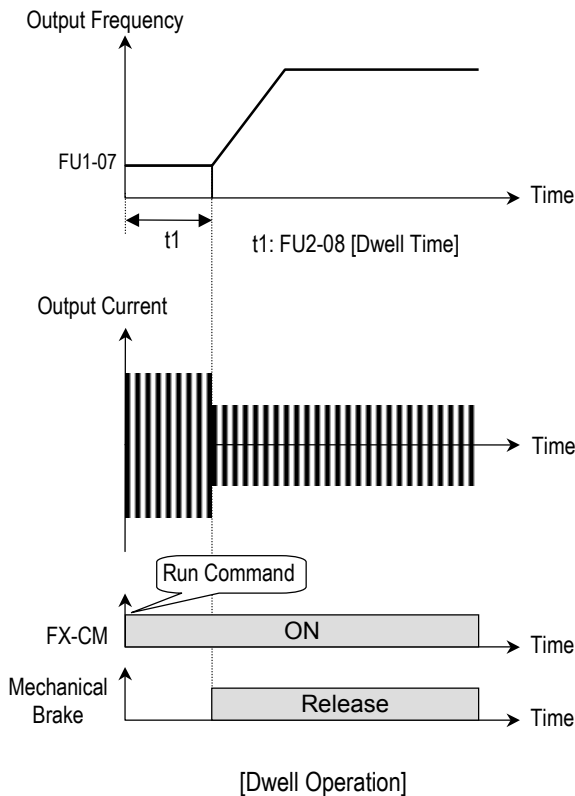

FU2-10 ~ FU2-16: Frequency Jump

- H 10
- H 11
- H 12
- H 13

- H 14
- H 15
- H 16

To prevent undesirable resonance and vibration on the structure of the machine, this function locks out the potential resonance frequency from occurring. Three different jump frequency ranges may be set. This avoidance of frequencies does not occur during accelerating or decelerating. It only occurs during continuous operation.

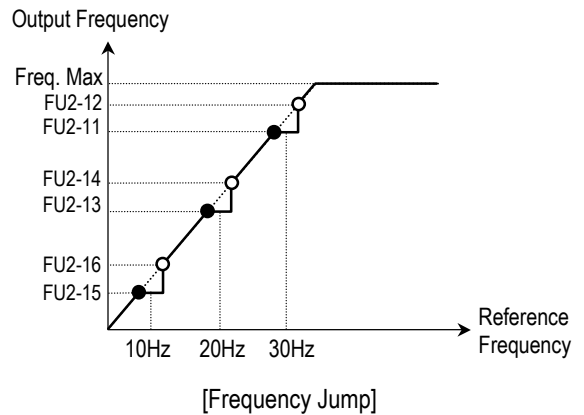

- Note:** When the reference frequency is set inside the jump frequency, the output frequency goes to the frequency marked by "●" symbol.
- Note:** If one frequency jump range is required, set all ranges to the same range.

FU2-19: Input/Output Phase Loss Protection (Bit Set)

- H 19

This function is used to cut the inverter output off in case of phase loss in either input power or inverter output.

Chapter 4 - Parameter Description [FU2]

FU2-19 [Phase Loss Protection Select]

Setting	Range		FU2-19	Description
	2 nd bit	1 st bit		
0	0	00		Phase loss protection does not work
0	1	01		Protect inverter from output phase loss
1	0	10		Protect inverter from input phase loss
1	1	11		Protect inverter from input and output phase loss

Related Functions: FU2-22 to FU2-25 [Speed Search]

FU2-20: Power ON Start Selection

H 20

If FUN-20 is set to 'No', restart the inverter by cycling the FX or RX terminal to CM terminal after power has been restored.

If FUN-20 is set to 'Yes', the inverter will restart after power is restored. If the motor is rotating by inertia at the time power is restored, the inverter may trip. To avoid this trip, use 'Speed Search' function by setting FU2-22 to '1xxx'.

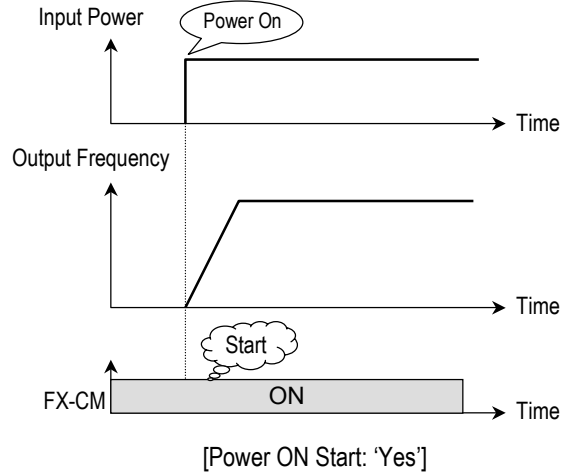
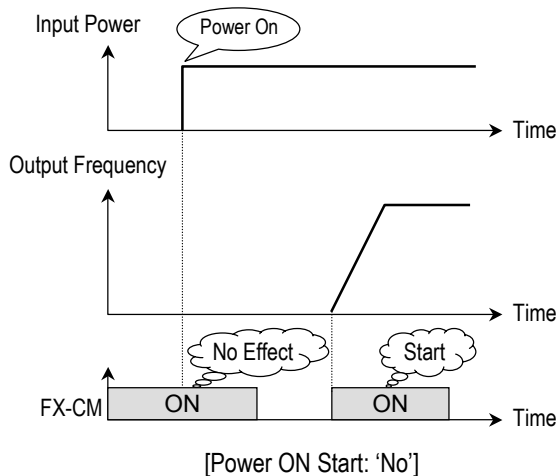

Note: In case of using 'Power ON Start' to 'Yes', make sure to utilize appropriate warning notices to minimize the potential for injury or equipment damage.

Related Functions: FU2-22 ~ FU2-25 [Speed Search]

FU2-21: Restart After Fault Reset

H 21

If FU2-21 is set to 'Yes', inverter will restart after the RST (reset) terminal has been reset a fault. If FU2-21 is set to 'No', restart the inverter by cycling the FX or RX terminal to CM terminal after the fault has been reset. If the motor is rotating by inertia at the time power is restored, the inverter may trip. To avoid this trip, use 'Speed Search' function by setting FU2-22 to 'xx1x'.

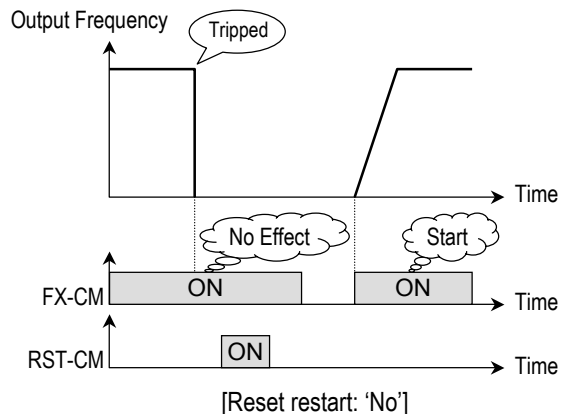

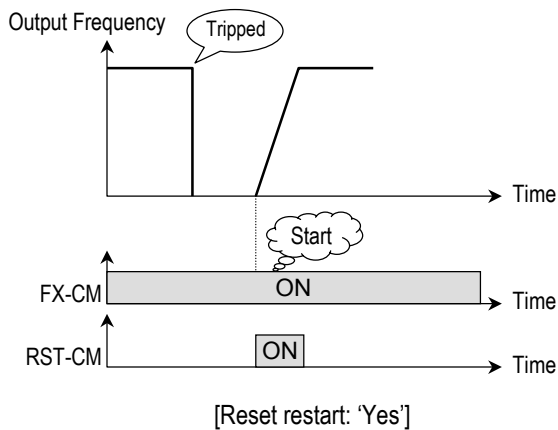

Note: In case of using 'Reset Restart' to 'Yes', make sure to utilize appropriate warning notices to minimize the potential for injury or equipment damage.

Related Functions: FU2-22 ~ FU2-25 [Speed Search]

- FU2-22: Speed Search Selection (Bit Set)
- FU2-23: Current Limit Level During Speed Search
- FU2-24: P Gain During Speed Search
- FU2-25: I Gain During Speed Search

H 22

H 23

H 24

H 25

This function is used to permit automatic restarting after Power ON, Fault Reset, and Instant Power Failure without waiting for the motor to stop.

The speed search gain should be set after considering the inertia moment (GD^2) and magnitude of torque of the load. FU2-37 [Load

Inertia] must be set at the correct value to make this function operate correctly.

FU2-22 [Speed Search Select]

Setting Range				Description
4 th bit	3 rd bit	2 nd bit	1 st bit	
0	0	0	0	Speed search function does not work
0	0	0	1	Speed search during Accelerating
0	0	1	0	Speed search during a Fault Reset restarting (FU2-21) and Auto restarting (FU2-26)
0	1	0	0	Speed search during Instant Power Failure restarting.
1	0	0	0	Speed search during Power ON starting (FU2-20)

When FU2-22 is set to '1111', Speed Search works for all conditions.

FU2-22 [Speed Search Selection] selects the speed search function.

FU2-23 [Current Limit Level] is the current that the inverter limits its current rise during speed searching. (The set value is the percentage of FU2-33 [Rated Motor Current])

FU2-24 [P Gain] is the proportional gain used for speed search. Set this value according to load inertia set in FU2-37.

FU2-25 [I Gain] is the Integral gain used for speed search. Set this value according to load inertia set in FU2-37.

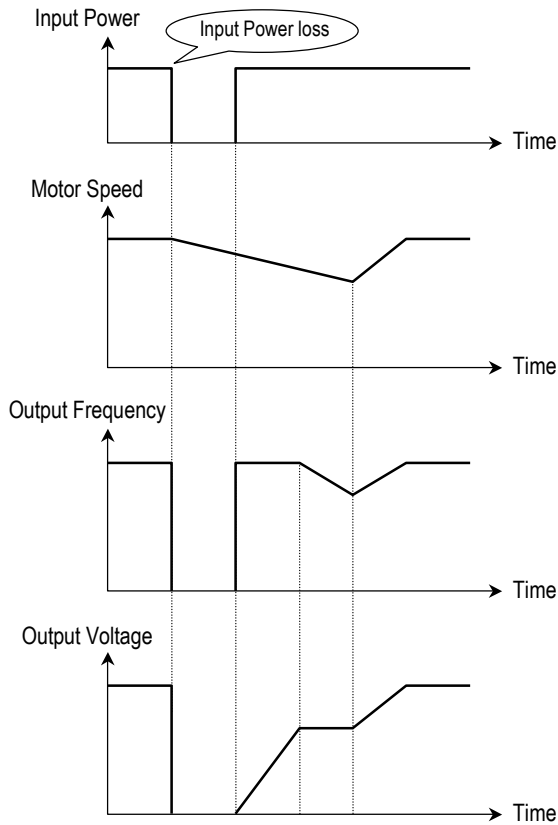

[Speed Search Operation]

Related Functions: FU2-20 [Power ON Start]
 FU2-21 [Restart after Fault Reset]
 FU2-26 ~ FU2-27 [Auto Restart]
 FU2-30 ~ FU2-37 [Motor Parameters]

FU2-26: Number of Auto Restart Attempt
FU2-27: Delay Time Before Auto Restart

H 26

H 27

This function is used to allow the inverter to reset itself for a selected number of times after a fault has occurred. The inverter can restart itself automatically when a fault occurs. To use the

speed search function during auto restarting set FU2-22 to 'xx1x'. See FU2-22 ~ FU2-25. When an under voltage (LV) fault, inverter disable (BX) or Arm short occurs, the drive does not restart automatically.

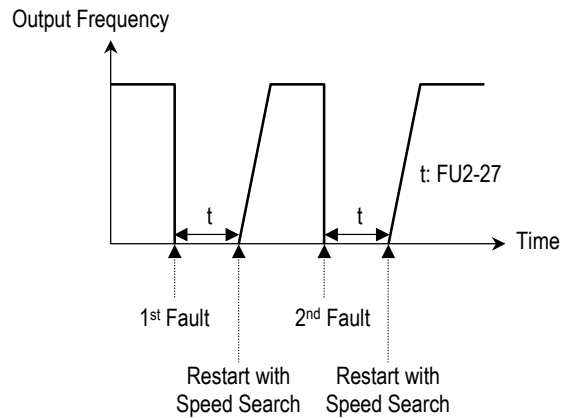

Note: Inverter decreases the retry number by one as a fault occurs. When restarted without a fault during 30 seconds, the inverter increases the retry number by one.

FU2-30: Rated Motor Selection
FU2-31: Number of Motor Pole
FU2-32: Rated Motor Slip
FU2-33: Rated Motor Current
FU2-34: No Load Motor Current
FU2-36: Motor Efficiency
FU2-37: Load Inertia

If you do not set these values, inverter will use its default values.

H 30

This parameter sets the motor capacity. Other motor related parameters are changed automatically according to motor capacity. The motor related parameters are FU2-32 [Rated Motor Slip], FU2-33 [Rated Motor Current], FU2-34 [No Load Motor Current].

If you know the motor parameters, set the values in the relevant codes for better control performance.

(This value is set according to the model number before shipping)

H 31

This is used to display the motor speed. If you set this value to 2, inverter will display 3600 rpm instead 1800rpm at 60Hz output frequency. (See motor nameplate)

H 32

This is used in 'Slip Compensation' control. If you set this value incorrectly, motor may stall during slip compensation control. (See motor nameplate)

H 33

This is very importance parameter that must be set correctly. This value is referenced in many other inverter parameters. (See motor nameplate)

H 34

This parameter is only displayed when 'Slip Compen' is selected in FU2-40 [Control Method].

This function is used to maintain constant motor speed. To keep the motor speed constant, the output frequency varies within the limit of slip frequency set in FU2-32 according to the load current. For example, when the motor speed decreases below the reference speed (frequency) due to a heavy load, the inverter increases the output frequency higher than the reference frequency to increase the motor speed. The inverter increases or decreases the output by delta frequency shown below.

$$\text{Delta Freq.} = \frac{\text{Output current} - \text{No load}}{\text{Rated current} - \text{No load}} \times \text{Rated Slip}$$

Output frequency = Reference freq. + Delta freq.

H 36

This value is used for calculating the output wattage when FU2-72 is set to 'Watt'.

H 37

This parameter is used for sensorless control, minimum Accel/Decel, optimum Accel/Decel and speed search. For better control performance, this value must be set as exact as possible.

Set '0' for loads that has load inertia less than 10 times that of motor inertia.

Set '1' for loads that have load inertia about 10 times that of motor inertia.

FU2-39: Carrier Frequency

H 39

This parameter affects the audible sound of the motor, noise emission from the inverter, inverter temperature, and leakage current. If the ambient temperature where the inverter is installed is high or other equipment may be affected by potential inverter noise, set this value lower.

This is also used to avoid an induced resonance in the machine or motor.

Note: If this value must be set higher than 3 kHz, derate the load current by 5% per 1 kHz.

FU2-40: Control Method Selection

H 40

This is to select the control method of inverter.

Setting Range		Description
Select	Display	
V/F	0	Volts/Hz Control
Slip compen	1	Slip compensation operation
PID	2	PID feedback operation

[V/F]: This parameter controls the voltage/frequency ratio constant. It is recommended to use the torque boost function when a greater starting torque is required.

Related Functions: FU2-26 ~ FU2-28 [Torque Boost]

[Slip compen]: This function is used to maintain constant motor speed. To keep the motor speed constant, the output frequency varies within the limit of slip frequency set in FU2-32 according to the load current. For example, when the motor speed decreases below the reference speed (frequency) due to a heavy load, the inverter increases the output frequency higher than the reference frequency to increase the motor speed. The inverter increases or decreases the output by delta frequency shown below.

$$\text{Delta Freq.} = \frac{\text{Output current} - \text{No load}}{\text{Rated current} - \text{No load}} \times \text{Rated Slip}$$

Output frequency = Reference freq. + Delta freq.

Note: Motor parameters must be set correctly for better performance of control.

Related Functions: FU2-30 ~ FU2-37 [Motor Parameters]

[PID]: For HVAC or Pump applications, the PID control can be used to adjust the actual output by comparing a feedback with a 'Set-point' given to

the inverter. This 'Set-point' can be in the form of Speed, Temperature, Pressure, Flow level, etc. The 'Set-point' and the feedback signals are provided externally to the inverter analog input terminals V1, V2 or I. The inverter compares the signals in calculating 'total-error' which is reflected in the inverter output.

Please see FU2-50 to FU2-54 for more detail.

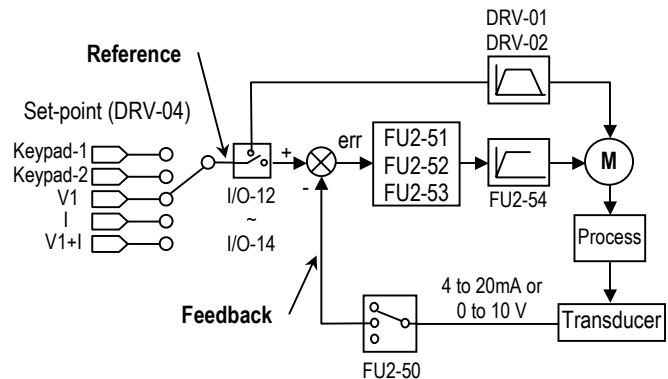

[PID Control Block Diagram]

Note: PID control can be bypassed to manual operation temporarily by defining one of the multifunction input terminals (P1~P3) to "Open-Loop". The inverter will change to manual operation from PID control when this terminal is ON, and change back to PID control when this terminal is OFF.

Related Functions: DRV-04 [Frequency Mode]
I/O-01 to I/O-10 [Analog Signal Setting]
I/O-12 to I/O-14 [Multi-Function Input]
FU2-50 to FU2-54 [PID Feedback]

FU2-50: PID Feedback Signal Selection
FU2-51: P Gain for PID Control
FU2-52: I Gain for PID Control
FU2-53: D Gain for PID Control
FU2-54: Limit Frequency for PID Control

H 50

Select the feedback signal for PID control. This can be set one of 'I', 'V1', 'V2' according to the signal (current or voltage) and the terminal (V1 or V2).

H 51

Set the proportional gain for PID control. When P-Gain is set at 100% and I-Gain at 0.0 second, it means the PID controller output is 100% for 100% error value.

H 52

Set the integral gain for PID control. This is the time the PID controller takes to output 100% for 100% error value.

H 53

Set the differential gain for PID control.

H 54

This is the frequency at which the output frequency is limited during PID control.

[P Control] This is to compensate the error of a system proportionally. This is used to make the controller response fast for an error. When P control is used alone, the system is easily affected by an external disturbance during steady state.

[I Control] This is to compensate the error of a system integrally. This is used to compensate the steady state error by accumulating them. Using this control alone makes the system unstable.

[PI control] This control is stable in many systems. If "D control" is added, it becomes the 3rd order system. In some systems this may lead to system instability.

[D Control] Since the D control uses the variation ratio of error, it has the merit of controlling the

error before the error is too large. The D control requires a large control quantity at start, but has the tendency of increasing the stability of the system. This control does not affect the steady state error directly, but increases the system gain because it has an attenuation effect on the system. As a result, the differential control component has an effect on decreasing the steady state error. Since the D control operates on the error signal, it cannot be used alone. Always use it with the P control or PI control.

Related Functions: DRV-04 [Frequency Mode]
FU2-40 [Control Method]
I/O-01 ~ I/O-10 [Analog Signal Scaling]

FU2-70: Reference Frequency for Accel/Decel

H 70

This is the reference frequency for acceleration and deceleration. If a decided Accel/Decel time from a frequency to a target frequency is required, set this value to 'Delta freq'.

Setting Range		Description
Select	Display	
Max freq	0	The Accel/Decel time is the time that takes to reach the maximum frequency from 0 Hz.
Delta freq	1	The Accel/Decel time is the time that takes to reach a target frequency from a frequency (currently operating frequency).

Related Functions: DRV-01, DRV-02 [Accel/Decel Time]
FU2-71 [Accel/Decel Time Scale]
I/O-25 ~ I/O-38 [1st ~ 7th Accel/Decel Time]

Chapter 4 - Parameter Description [FU2]

FU2-71: Accel/Decel Time Scale

H 71

This is used to change the time scale.

Related Functions: DRV-01, DRV-02 [Accel/Decel Time]
FU2-70 [Reference Freq. for Accel/Decel]
I/O-25 ~ I/O-38 [1st ~ 7th Accel/Decel Time]

Setting Range		Description
Select	Display	
0.01 sec	0	The Accel/Decel time is changed by 0.01 second. The maximum setting range is 600 seconds.
0.1 sec	1	The Accel/Decel time is changed by 0.1 second. The maximum setting range is 6000 seconds.
1 sec	2	The Accel/Decel time is changed by 1 second. The maximum setting range is 60000 seconds.

FU2-72: Power On Display

H 72

This code selects the parameter to be displayed first on keypad (DRV-00) when the power is turned on.

Setting Range	Description
0	DRV-00 [Command Frequency]
1	DRV-01 [Acceleration Time]
2	DRV-02 [Deceleration Time]
3	DRV-03 [Drive Mode]
4	DRV-04 [Frequency Mode]
5	DRV-05 [Step Frequency 1]
6	DRV-06 [Step Frequency 2]
7	DRV-07 [Step Frequency 3]
8	DRV-08 [Output Current]
9	DRV-09 [Motor Speed]
10	DRV-10 [DC link Voltage]

11	DRV-11 [User Display selected in FU2-73]
12	DRV-12 [Fault Display]
13	DRV-13 [Motor Direction]

FU2-73: User Display Selection

H 73

This code selects the kind of display to be displayed in code DRV-11.

Setting range		Description
Select	Display	
Voltage	0	Displays the output voltage of inverter.
Watt	1	Displays the output power of inverter.
Torque	2	Displays the output torque of inverter.

 **Note:** The display of 'Watt' and 'Torque' is approximate value.

Related Functions: DRV-11 [User Display]

FU2-74: Gain for Motor Speed Display

H 74

This code is used to change the motor speed display to rotating speed (r/min) or mechanical speed (m/min). The display is calculated by following equation.

Rotating speed = $120 \times F / P$, where F=Output frequency, P= motor pole number

Mechanical speed = Rotating speed x Motor RPM Display Gain

Related Functions: DRV-00 [Output Frequency]
DRV-09 [Motor Speed]
FU2-31 [Number of Motor Pole]

FU2-75: DB (Dynamic Braking) Resistor Mode Selection

H 75

This code is used to protect the DB resistor from over heating.

Setting Range		Description
Select	Display	
None	0	This is selected when there is no resistor connected. At this time, inverter does not generate DB turn on signal.
None	1	
Ext. DB-R	2	This is selected when using an external DB resistor. Enable Duty (%): 0 ~ 30 % Continuous Turn On Time: 15 seconds

- ☞ The inverter turns the DB turn on signal OFF when the Continuous Turn On Time expires during dynamic braking, and an over voltage fault can occur. When this happens, increase the deceleration time or install an external high-duty DB resistor.
- ☞ Install an exterior high-duty DB resistor when the load accelerates and decelerates frequently. Set the FU2-75 [DB Resistor Mode selection] to 'Ext. DB-R', and set the FU2-76 [Duty of DB Resistor].

FU2-76: Duty of DB (Dynamic Braking) Resistor

H 76

This must be set when using an external DB resistor. The duty is calculated by '%ED=Decel time * 100 / (Accel time + Steady speed time + Decel time + Stop status time)'.

FU2-79: Software Version

H 79

Displays the software version.

FU2-81 ~ FU2-90: 2nd Motor Related Functions

H 81



H 90

These functions are displayed only when one of the multifunction inputs is set at '2nd func' in I/O-12 to I/O-14.

When using two motors with an inverter by exchanging them, different values can be set for the 2nd motor by using the multifunction input terminal.

Following table is the 2nd functions corresponding to the 1st functions.

2 nd Functions	1 st Functions	Description
FU2-81 [2nd Acc time]	DRV-01 [Acc. time]	Acceleration time
FU2-82 [2nd Dec time]	DRV-02 [Dec. time]	Deceleration time
FU2-83 [2nd Base Freq]	FU1-21 [Base freq]	Base Frequency
FU2-84 [2nd V/F]	FU1-29 [V/F Pattern]	Volts/Hz mode
FU2-85 [2nd F-boost]	FU1-27 [Fwd Boost]	Forward torque boost
FU2-86 [2nd R-boost]	FU1-28 [Rev Boost]	Reverse torque boost
FU2-87 [2nd Stall]	FU1-60 [Stall Level]	Stall prevention level
FU2-88 [2nd ETH 1min]	FU1-51 [ETH 1min]	ETH level for 1 minute
FU2-88 [2nd ETH cont]	FU1-52 [ETH cont]	ETH level for continuous
FU2-90 [2nd R-Curr]	FU2-33 [Rated-Curr]	Motor rated current

Chapter 4 - Parameter Description [FU2]

- ☞ The 1st functions are applied if the multifunction terminal is not defined to '2nd Func' or if it is not ON. The 2nd function parameters are applied when the multifunction input terminal set to '2nd Func' is ON. Parameters not listed on the table above are applied to the 2nd motor as to the 1st motor.
- ☞ Exchange the motor connection from the 1st motor to the 2nd motor or the opposite when the motor is stopped. Over voltage or over current fault can occur when the motor connection is exchanged during operation.
- ☞ The 'User V/F' function of FU1-29 [V/F Pattern] is used for both the 1st motor and the 2nd motor.

FU2-91: Parameter Read FU2-92: Parameter Write



This is useful for programming multiple inverters to have same parameter settings. The keypad can read (upload) the parameter settings from the inverter memory and can write (download) them to other inverters.

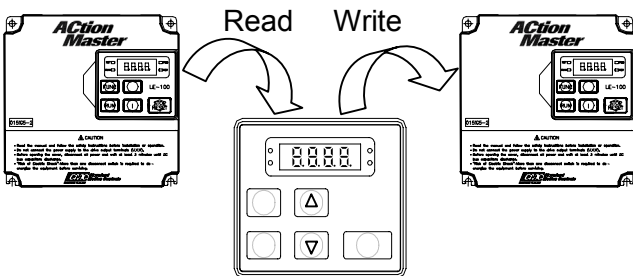

FU2-93: Parameter Initialize



This is used to initialize parameters back to the factory default values. Each parameter group can be initialized separately.

Setting Range		Description
Select	Display	
No	0	Displayed after initializing parameters.
All Groups	1	All parameter groups are initialized to factory default value.
DRV	2	Only Drive group is initialized.
FU1	3	Only Function 1 group is initialized.
FU2	4	Only Function 2 group is initialized.
I/O	5	Only Input/Output group is initialized.

- ☞ **Note:** FU1-30 ~ FU1-37 [Motor Parameters] must be set first after initializing parameters.

FU2-94: Parameter Write Protection



This function is used to lock the parameters from being changed. The lock and unlock code is '12'. Keypad displays "U 0" when unlocked and "L 0" when locked.

FU2-99: Return Code



This code is used to exit a group. Press [FUNC] key to exit.

Related Functions: FU1-99 [Return Code]
I/O-99 [Return Code]

Notes:

4.4 Input/Output Group [I/O]

I/O-00: Jump to Desired Code

1 0

Jumping directly to any parameter code can be accomplished by entering the desired code number.

I/O-01 ~ I/O-05: Analog Voltage Input (V1) Signal Adjustment

This is used to adjust the analog voltage input signal when the frequency is referenced by the control terminal 'V1'. This function is applied when DRV-04 is set to 'V1' or 'V1+I'. Reference frequency versus Analog voltage input curve can be made by four parameters of I/O-02 ~ I/O-04.

1 1

This is the filtering time constant for V1 signal input. Increase this value if the V1 signal is affected by noise causing unstable operation of the inverter. Increasing this value makes response time slower.

1 2

This is the minimum voltage of the V1 input at which inverter outputs minimum frequency.

1 3

This is the inverter output minimum frequency when there is the minimum voltage (I/O-02) on the V1 terminal.

1 4

This is the maximum voltage of the V1 input at which inverter outputs maximum frequency.

1 5

This is the inverter output maximum frequency when there is the maximum voltage (I/O-03) on the V1 terminal.

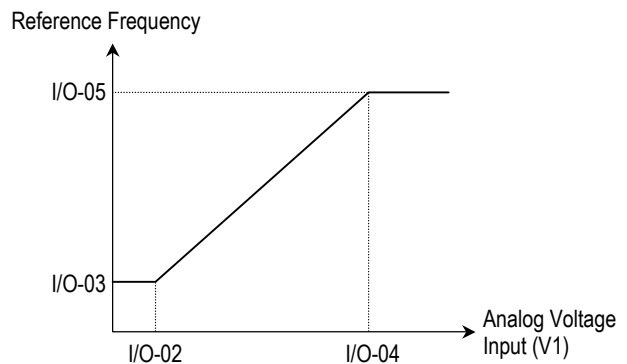

[Reference Frequency vs. Analog Voltage Input, V1 (0 to 10V)]

Related Functions: DRV-04 [Frequency Mode]
FU1-20 [Maximum Frequency]

I/O-06 ~ I/O-10: Analog Current Input (I) Signal Adjustment

This is used to adjust the analog current input signal when the terminal 'I' references the frequency. This function is applied when DRV-04 is set to 'V1' or 'V1+I'. Reference frequency versus Analog current input curve can be made by four parameters of I/O-07 ~ I/O-10.

1 6

This is the filtering time constant for 'I' signal input. If the 'I' signal is affected by noise causing unstable operation of the inverter, increase this value. Increasing this value makes response time slower.



This is the minimum current of the 'I' input at which inverter outputs minimum frequency.



This is the inverter output minimum frequency when there is minimum current (I/O-07) on the 'I' terminal.



This is the maximum current of the 'I' input at which inverter outputs maximum frequency.



This is the inverter output maximum frequency when there is the maximum current (I/O-09) on the 'I' terminal.

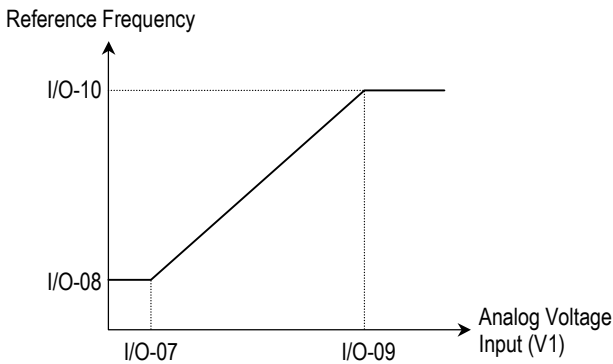

[Reference Frequency vs. Analog Current Input, I (4 to 20mA)]

Related Functions: DRV-04 [Frequency Mode]
FU1-20 [Maximum Frequency]

I/O-11: Criteria for Analog Input Signal Loss



This is to set the criteria for analog input signal loss when DRV-04 [Frequency Mode] is set to 'V1', 'I' or 'V1+I'. Following table shows the setting value.

Setting Range		Description
Select	Display	
None	0	Does not check the analog input signal.
half of x1	1	The inverter determines that the frequency reference is lost when the analog input signal is less than half of the minimum value (I/O-02 or I/O-07).
below x1	2	The inverter determines that the frequency reference is lost when the analog input signal is less than the minimum value (I/O-02 or I/O-07).

When the analog input signal is lost, inverter displays the following.



Related Functions: I/O-48 [Lost command] selects the operation after determining the loss of frequency reference.

The following table shows the selection in I/O-48.

Setting Range		Description
Select	Display	
None	0	Continuous operating after loss of frequency reference.
FreeRun	1	Inverter cuts off its output after determining loss of frequency reference.
Stop	2	Inverter stops by its Decel pattern and Decel time after determining loss of frequency reference.

I/O-49 [Time out] sets the waiting time before determining the loss of reference signal. Inverter

Chapter 4 - Parameter Description [I/O]

waits to determine the loss of a reference signal until times out.

Note: I/O-48 and I/O-49 also apply when DRV-04 is set to 'Keypad-1' or 'Keypad-2' for determining the loss of command frequency.

Related Functions:	DRV-04 [Frequency Mode] I/O-02 [V1 Input Minimum Voltage] I/O-07 [I Input Minimum Current] I/O-48 [Lost command] I/O-49 [Time out]
---------------------------	--

I/O-12: Multi-function Input Terminal 'P1' Define
I/O-13: Multi-function Input Terminal 'P2' Define
I/O-14: Multi-function Input Terminal 'P3' Define

1 12

1 13

1 14

Multi-function input terminals can be defined for many different applications. The following table shows the various definitions for them.

Setting Range		Description
Select	Display	
Speed-L	0	Multi-step speed - Low
Speed-M	1	Multi-step speed - Mid
Speed-H	2	Multi-step speed - High
XCEL-L	3	Multi-accel/decel - Low
XCEL-M	4	Multi-accel/decel - Mid
XCEL-H	5	Multi-accel/decel - High
DC-Brake	6	DC injection braking during stop
2nd Func	7	Reserved for future use
-Reserved-	8	Exchange to commercial power line
V1-Ext	9	Exchange freq. reference source to V1 input
Up	10	Up drive
Down	11	Down drive
3-Wire	12	3 wire operation
Ext Trip-A	13	External trip A

Setting Range		Description
Select	Display	
Ext Trip-B	14	External trip B
-Reserved-	15	Reserved for future use
Open-Loop	16	Exchange between PID mode and V/F mode
-Reserved-	17	Reserved for future use
Analog Hold	18	Hold the analog input signal
XCEL Stop	19	Disable accel and decel
-Reserved-	20	Reserved for future use
	21	
	22	
	23	
	24	
	25	
	26	

[Speed-L, Speed-M, Speed-H]

By setting P1, P2, P3 terminals to 'Speed-L', 'Speed-M' and 'Speed-H' respectively, inverter can operate at the preset frequency set in DRV-05 ~ DRV-07 and I/O-20 ~ I/O-24.

The step frequencies are determined by the combination of P1, P2 and P3 terminals as shown in the following table.

Step Frequency	Parameter Code	Speed-H (P3)	Speed-M (P2)	Speed-L (P1)
Step Freq-0	DRV-00	0	0	0
Step Freq-1	DRV-05	0	0	1
Step Freq-2	DRV-06	0	1	0
Step Freq-3	DRV-07	0	1	1
Step Freq-4	I/O-21	1	0	0
Step Freq-5	I/O-22	1	0	1
Step Freq-6	I/O-23	1	1	0
Step Freq-7	I/O-24	1	1	1

0: OFF, 1: ON

Note: I/O-20 [Jog Frequency] can be used as one of the step frequencies.

Note: If the 'Jog' terminal is ON, inverter operates to Jog frequency regardless of other terminal inputs.

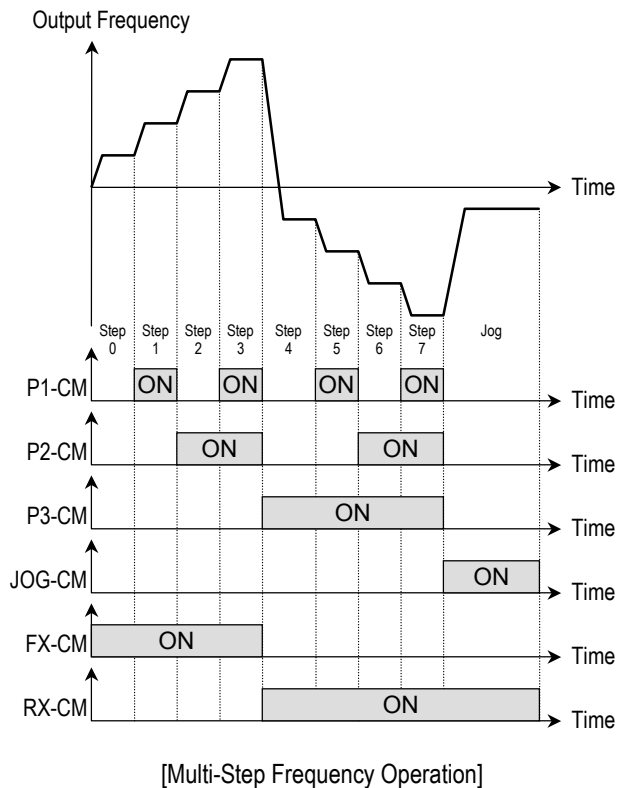

Related Functions: DRV-05 ~ DRV-07 [Step Frequency]
 I/O-20 [Jog Frequency]
 I/O-21 ~ I/O-24 [Step Frequency]

Note: The frequency for 'Speed 0' is determined by DRV-04.

[XCEL-L, XCEL-M, XCEL-H]

By setting P1, P2 and P3 terminals to 'XCEL-L', 'XCEL-M' and 'XCEL-H' respectively, up to 8 different Accel and Decel times can be used. The Accel/Decel time is set in DRV-01 ~ DRV-02 and I/O-25 ~ I/O-38.

The Accel/Decel time is determined by the combination of P1, P2 and P3 terminals as shown in the following table.

Accel/Decel Time	Parameter Code	XCEL-H (P3)	XCEL-M (P2)	XCEL-L (P1)
Accel Time-0	DRV-01	0	0	0
Decel Time-0	DRV-02			
Accel Time-1	I/O-25	0	0	1
Decel Time-1	I/O-26			
Accel Time-2	I/O-27	0	1	0
Decel Time-2	I/O-28			

Accel/Decel Time	Parameter Code	XCEL-H (P3)	XCEL-M (P2)	XCEL-L (P1)
Accel Time-3	I/O-29	0	1	1
Decel Time-3	I/O-30			
Accel Time-4	I/O-31	1	0	0
Decel Time-4	I/O-32			
Accel Time-5	I/O-34	1	0	1
Decel Time-5	I/O-35			
Accel Time-6	I/O-36	1	1	0
Decel Time-6	I/O-37			
Accel Time-7	I/O-38	1	1	1
Decel Time-7	I/O-39			

0: OFF, 1: ON

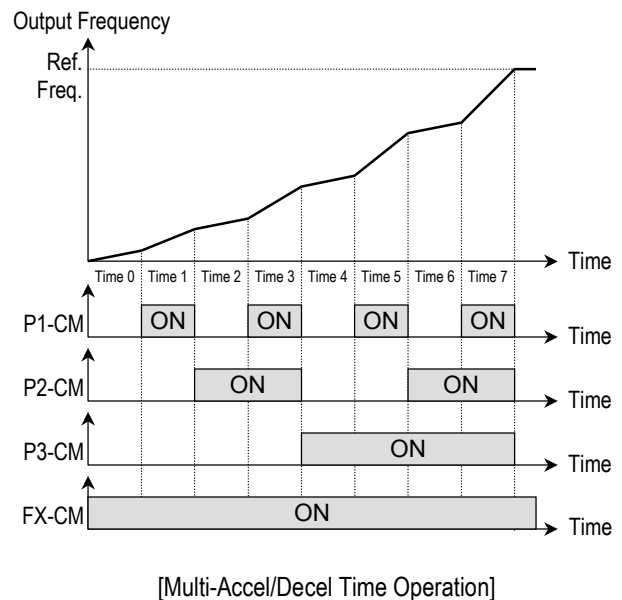

Related Functions: I/O-25 ~ I/O-38 [1st ~7th Accel/Decel Time]

[DC-Brake]

DC Injection Braking can be activated during inverter stopped by configuring one of the multi-function input terminals (P1, P2, P3) to 'DC-Bake'. To activate the DC Injection Braking, close the contact on the assigned terminal while the inverter is stopped.

[2nd Function]

Inverter uses parameters set in FU2-81 ~ 89 when this terminal is ON. This function must be used when motor is stopped to avoid over current

Chapter 4 - Parameter Description [I/O]

or over voltage trip.

[V1-Ext]

Inverter changes its frequency reference source from keypad to 'V1' (analog voltage input) when this terminal is ON.

[Up, Down]

By using the Up and Down function, the drive can accelerate to a steady speed and decelerate down to a desired speed by using only two input terminals.

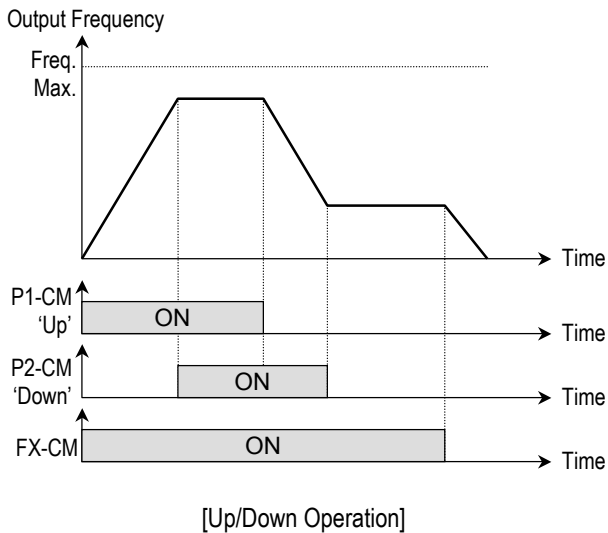

[3-Wire]

This function is for 3-wire start/stop control. This function is mainly used with a momentary push button to hold the current frequency output during acceleration or deceleration.

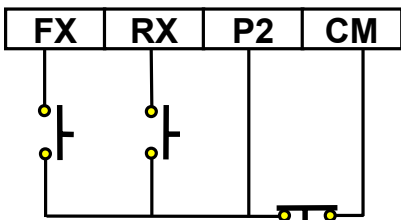

[Wiring for 3-Wire Operation, P2 set to '3-Wire']

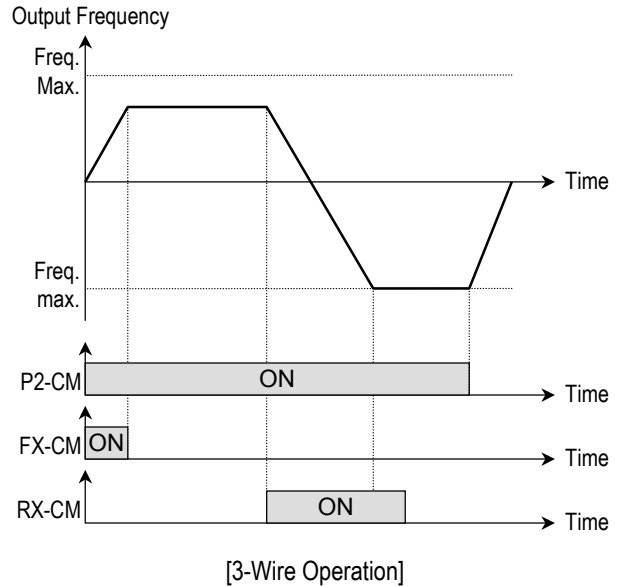

[Ext Trip-A]

This is a normally open contact input. When a terminal set to 'Ext Trip-A' is ON, inverter displays the fault and cuts off its output. This can be used as an external latch trip.

[Ext Trip-B]

This is a normally closed contact input. When a terminal set to 'Ext Trip-B' is OFF, inverter displays the fault and cuts off its output. This can be used as an external latch trip.

[Open-Loop]

This is used to exchange the control mode of inverter from PID mode (Close Loop) to V/F mode (Open Loop).

DRV-03 [Drive Mode] and DRV-04 [Frequency Mode] are applied when the mode has been changed.

Note: This function can be used only when the inverter is stopped.

[Analog Hold]

When there is an analog input signal for frequency reference and 'Analog hold' terminal is ON, inverter fixes its output frequency regardless of the frequency reference change. The changed frequency reference is applied when the terminal is OFF.

This function is useful when a system requires constant speed after acceleration.

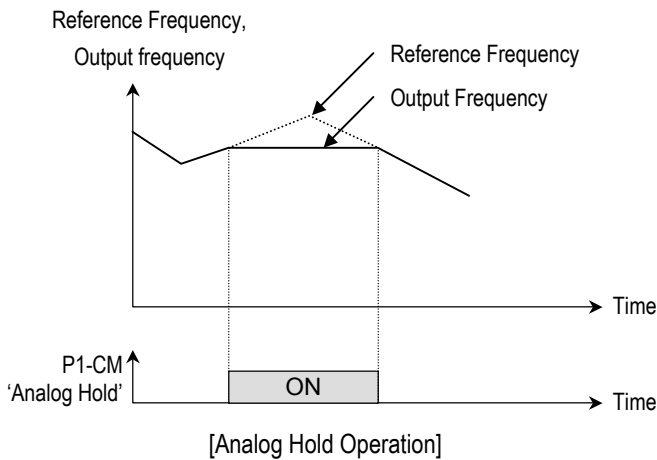

I/O-15: Terminal Input Status
I/O-16: Terminal Output Status



This code displays the input status of control terminals.

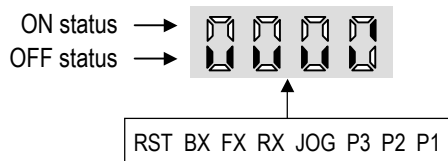

This code displays the output status of control terminals.

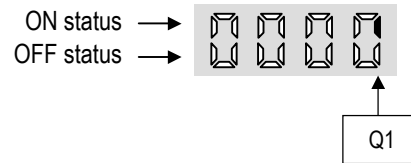

I/O-17: Filtering Time Constant for Multi-function Input Terminals



This is the response time constant for terminal inputs (JOG, FX, RX, P3, P2, P1, RST, BX). This is useful where there is a potential for noise. The response time is determined by 'Filtering time constant * 0.5msec'.

I/O-20: Jog Frequency



This code sets the jog frequency. See [Speed-L, Speed-M, Speed-H] in I/O-12 ~ I/O-14. Jog terminal has priority over any other input terminal in action.

I/O-21 ~ I/O-24: Step Frequency 4, 5, 6, 7



1 24

These codes set the step frequencies. These frequencies are applied when the multi-function input terminals (P1, P2, P3) select the step. See [Speed-L, Speed-M, Speed-H] in I/O-12 ~ I/O-14.

Related Functions: DRV-05 ~ DRV-07 [Step Frequency 1 ~ 3]
I/O-12 ~ I/O-14 [Multi-function inputs]
I/O-17 [Filtering Time Constant]

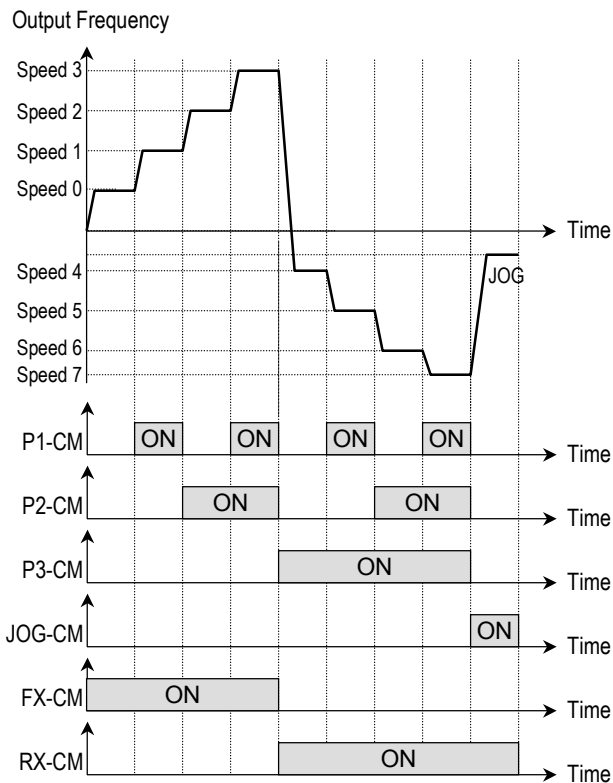

[‘JOG’ and ‘Multi-Step’ Operation]

I/O-25 ~ I/O-38: 1st ~ 7th Accel/Decel Time

1 25



1 38

These codes are applied when the multi-function input terminals (P1, P2, P3) select the Accel/Decel time. See [XCEL-L, XCEL-M, XCEL-H] in I/O-12 ~ I/O-14.

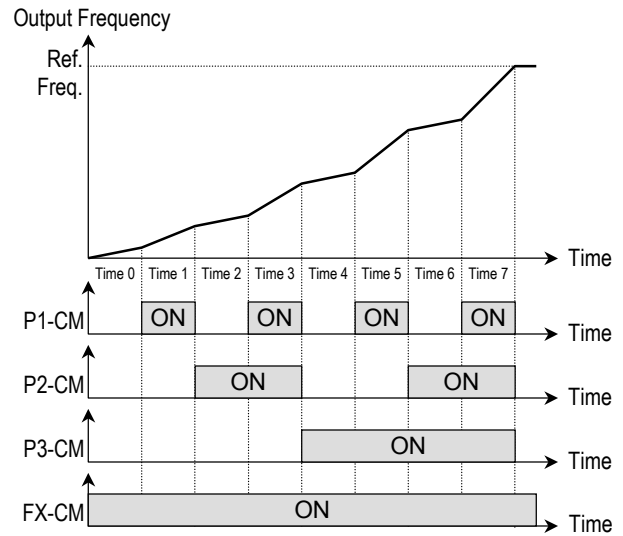

[Multi-Accel/Decel Time Operation]

Related Functions: I/O-25 ~ I/O-38 [1st ~ 7th Accel/Decel Time]

Related Functions: DRV-01 ~ DRV-02 [Accel/Decel Time]
FU2-70 [Reference Freq. for Accel/Decel]
FU2-71 [Accel/Decel Time Scale]
I/O-12 ~ I/O-14 [Multi-function inputs]

I/O-40: FM (Frequency Meter) Output
I/O-41: FM Adjustment

1 40

1 41

Frequency meter displays the inverter output Frequency, Current, Voltage and DC link voltage with pulse signals on the FM terminal. The

average ranges from 0V to 10V. I/O-41 is used to adjust the FM value.

[Frequency]

FM terminal outputs inverter output frequency. The output value is determined by,
 FM Output Voltage = (Output freq. / Max. freq.) × 10V × IO-41 / 100

[Current]

FM terminal outputs inverter output current. The output value is determined by,
 FM Output Voltage = (Output current / Rated current) × 10V × IO-41 / 150

[Voltage]

FM terminal outputs inverter output voltage. The output value is determined by,
 FM Output Voltage = (Output voltage / Max. output voltage) × 10V × IO-41 / 100

[DC link vtg]

FM terminal outputs the DC link voltage of inverter. The output value is determined by,
 FM Output Voltage = (DC link voltage / Max. DC link voltage) × 10V × IO-41 / 100

**I/O-42: FDT (Frequency Detection) Level
 I/O-43: FDT Bandwidth**



These functions are used in I/O-44 [Multi-function Output]. See [FDT-#] in I/O-44.

Related Functions: I/O-44 [Multi-function Output]

I/O-44: Multi-function Output define (MO-MG)



The open collector output works (Close) when the defined condition has occurred.

Setting Range		Description
Select	Display	
FDT-1	0	Output frequency arrival detection
FDT-2	1	Specific frequency level detection
FDT-3	2	Frequency detection with pulse
FDT-4	3	Frequency detection with contact closure
FDT-5	4	Frequency detection with contact closure (inverted FDT-4)
OL	5	Overload detection
IOL	6	Inverter overload detection
Stall	7	Stall prevention mode detection
OV	8	Over voltage detection
LV	9	Low voltage detection
OH	10	Overheat detection
Lost Command	11	Lost command detection
Run	12	Inverter running detection
Stop	13	Inverter stop detection
Steady	14	Steady speed detection
-Reserved-	15~16	Reserved for future use
Ssearch	17	Speed search mode detection
-Reserved-	18~19	Reserved for future use
Ready	20	Inverter is ready status to run

[FDT-1]

When the output frequency reaches the reference frequency (target frequency), MO-MG terminal is CLOSED.

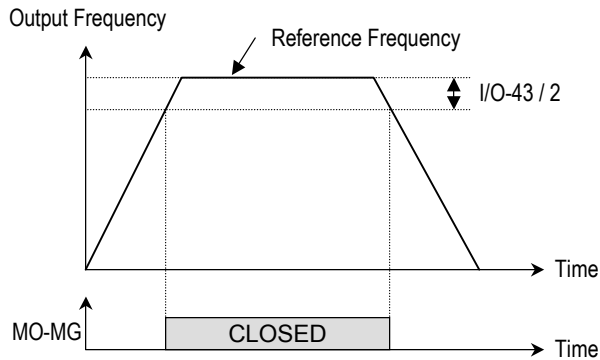

[MO-MG configured as 'FDT-1']

[FDT-2]

MO-MG is CLOSED when the reference frequency is in I/O-43 [FDT Bandwidth] centered on I/O-42 [FDT Frequency], and the output frequency reaches I/O-43 centered on I/O-42.

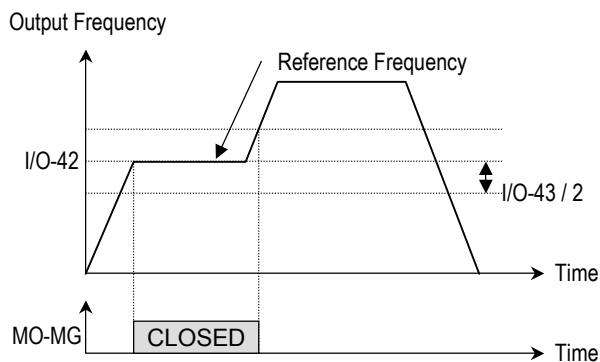

[MO-MG configured as 'FDT-2']

[FDT-3]

MO-MG is CLOSED when the output frequency reaches the band centered on the FDT frequency. The output is OPENED when the output frequency goes outside the FDT bandwidth centered on the FDT frequency.

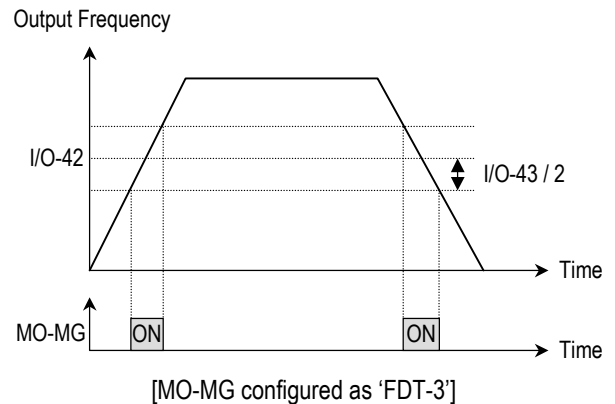

[MO-MG configured as 'FDT-3']

[FDT-4]

MO-MG is CLOSED when the output frequency reaches the FDT frequency. The output is OPENED when the output frequency goes below the FDT bandwidth centered on the FDT frequency.

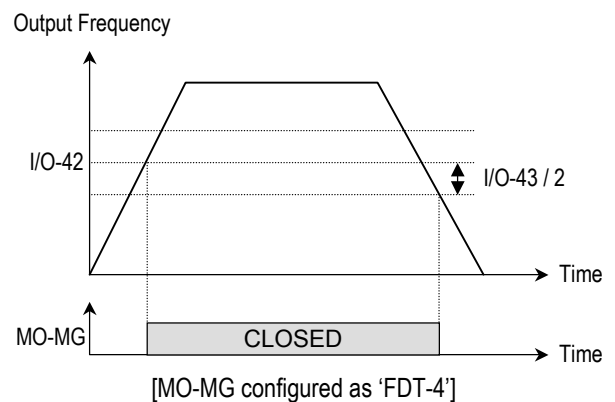

[MO-MG configured as 'FDT-4']

[FDT-5]

This is the inverted output of [FDT-4].

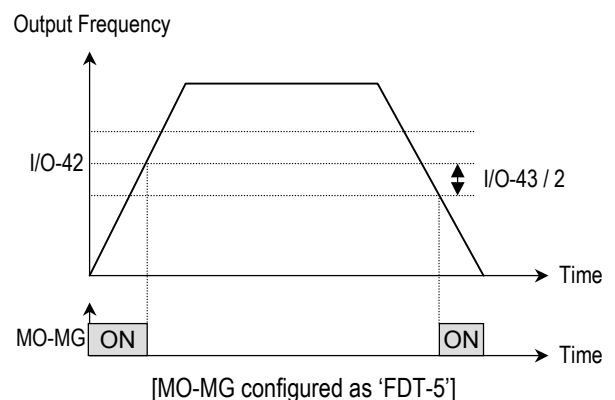

[MO-MG configured as 'FDT-5']

[OL]

MO-MG is CLOSED when the output current has reached the FU1-54 [Overload Warning Level] for the FU1-55 [Overload Warning Time].

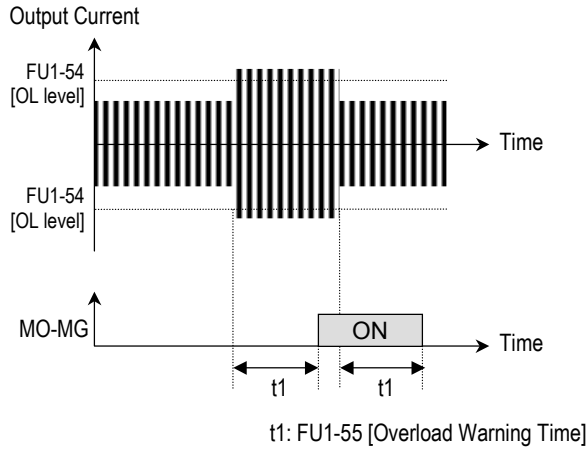

[MO-MG configured as 'OL']

Related Functions: FU1-54 [Overload Warning Level]
FU1-55 [Overload Warning Time]

[IOL]

MO-MG is CLOSED when the output current is above the 150% of rated inverter current for 36 seconds. If this situation is continued for one minute, the inverter will cut off its output and displays 'IOLT' (Inverter overload trip). See the nameplate for the rated inverter current.

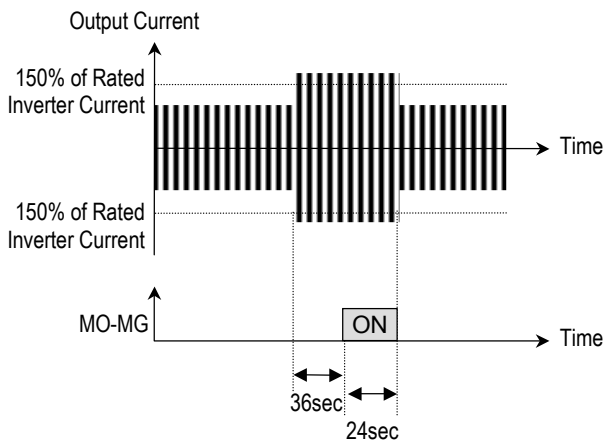

[MO-MG configured as 'IOL']

[Stall]

MO-MG is CLOSED when the inverter is on the stall prevention mode.

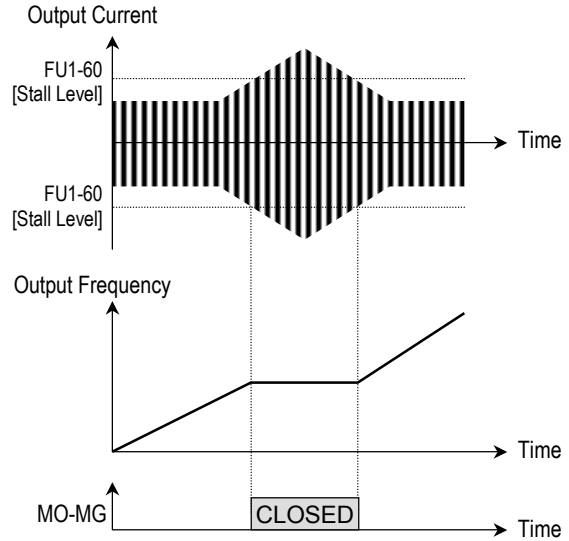

[MO-MG configured as 'Stall']

Related Functions: FU1-59 [Stall Prevention Mode]
FU1-60 [Stall Prevention Level]

[OV]

MO-MG is CLOSED when the DC link voltage is above the Over-voltage level.

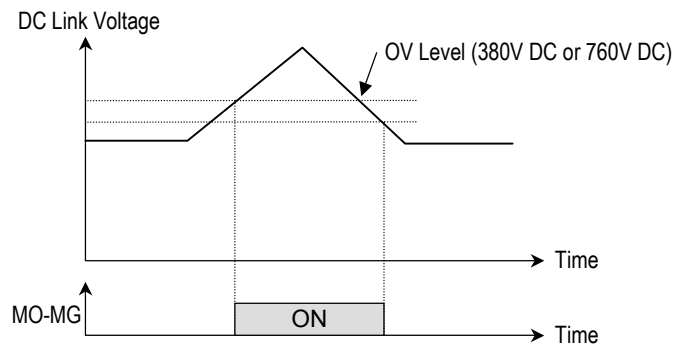

[MO-MG configured as 'OV']

[LV]

MO-MG is CLOSED when the DC link voltage is below the Low-voltage level.

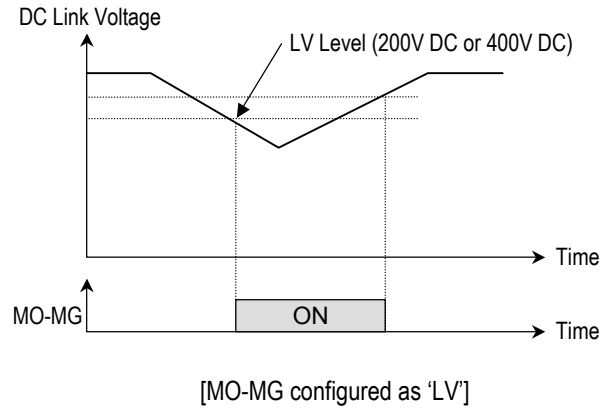

[OH]

MO-MG is CLOSED when the heat sink of the inverter is above the reference level.

[Lost Command]

MO-MG is CLOSED when frequency reference is lost.

Related Functions: I/O-11 [Criteria for Analog Signal Loss]
 I/O-48 [Operating Method at Signal Loss]
 I/O-49 [Waiting Time for Time Out]

[Run]

MO-MG is CLOSED when the inverter is running.

[Stop]

MO-MG is CLOSED when the inverter is stopped.

[Steady]

MO-MG is CLOSED when the inverter is steady speed status.

[Ssearch]

MO-MG is CLOSED during the inverter is speed searching.

[Ready]

MO-MG is CLOSED when the inverter is ready to run.

I/O-45: Fault Output Relay (30A, 30B, 30C)

1 45

This function is used to allow the fault output relay to operate when a fault occurs. The output relay terminal is 30A, 30B, 30C where 30A-30C is a normally open contact and 30B-30C is a normally closed contact.

Bit	Setting	Display	Description
Bit 0 (LV)	0	000	Fault output relay does not operate at 'Low voltage' trip.
	1	001	Fault output relay operates at 'Low voltage' trip.
Bit 1 (Trip)	0	000	Fault output relay does not operate at any fault.
	1	010	Fault output relay operates at any fault except 'Low voltage' and 'BX' (inverter disable) fault.
Bit 2 (Retry)	0	000	Fault output relay does not operate regardless of the retry number.
	1	100	Fault output relay operates when the retry number set in FU2-26 decreases to 0 by faults.

☞ When several faults occurred at the same time, Bit 0 has the first priority.

Related Functions: DRV-12 [Fault Display]
 FU2-26 [Retry Number]

I/O-46: Inverter Number

I/O-47: Baud Rate

1 46

This code sets the inverter number. This number is used in communication between inverter and communication board.



This code sets the communication speed. This is used in communication between inverter and communication board.

I/O-48: Operating at Loss of Freq. Reference
I/O-49: Waiting Time after Loss of Freq. Reference



There are two kinds of loss of frequency reference. One is the loss of digital frequency reference and the other is of analog frequency reference.

Loss of digital frequency reference is applied when DRV-04 [Frequency Mode] is set to 'Keypad-1' or 'Keypad-2'. At this time, the 'Loss' means the communication error between inverter and keypad or communication board during the time set in I/O-49.

Loss of analog frequency reference is applied when DRV-04 [Frequency Mode] is set to other than 'Keypad-1' or 'Keypad-2'. At this time, the 'Loss' is determined by the criteria set in I/O-11 [Criteria for Analog Input Signal Loss].

Setting Range		Description
Select	Display	
None	0	Inverter keeps on operating at the previous frequency.
FreeRun (Coast to stop)	1	Inverter cuts off its output.
Stop	2	Inverter stops with Decel time (DRV-02) and Decel pattern (FU1-26).



This is the time inverter determines whether there is a frequency reference or not. If there is no frequency reference satisfying I/O-11 during this time, inverter determines that it has lost of frequency reference.

Related Functions: DRV-04 [Frequency Mode]
 I/O-11 [Criteria for Analog Signal Loss]

I/O-50: Communication Protocol Selection



This code selects the RS485 protocol between inverter and computer.

Setting Range		Description
Select	Display	
CMC-Bus ASCII	0	8 bit Data, No Parity, 1 Stop
Modbus RTU	7	8 bit Data, No Parity, 2 Stop

I/O-99: Return Code (7-Segment Keypad)



This code is used to exit a group. Press [FUNC] key to exit.

CHAPTER 5 - MODBUS-RTU COMMUNICATION

5.1 Introduction

This manual is about the specifications, installation and operation of MODBUS-RTU for communication with PC or FA computer.

5.1.1 Features

Easy use of drives in Factory Automation by user programming
Change and monitoring of drive parameters using computer

5.1.2 Interfacing type of RTU Reference:

- Allows the drive to communicate with any other computers.
- Allows connection of up to 31 drives with multi-drop link system.
- Ensure noise-resistant interface.

Users can use any kind of RS232-485 converters. However a converter that has built-in 'automatic RTS control' is highly recommended. Because the specifications of converters depend on the manufacturers, please refer to the manual for detailed converter specifications.

5.1.3 Before Installation

Before installation and operation, this manual should be read thoroughly. If not, it can cause personal injury or damage other equipment.

5.2 Specifications

5.2.1 Performance Specifications

Items	Specifications
Communication method	RS485
Transmission form	Bus method Multi-drop Link System
Applicable inverter	ACTIONMASTER series drive
Number of drives	Maximum 31 drives connectable
Transmission distance	Max. 1200m

5.2.2 Hardware Specifications

Items	Specifications
Installation	S+, S-, CM terminals on control terminal strip
Power Supply	Insulated from the inverter power supply

5.2.3 Communication Specifications

Items	Specifications
Communication speed	19200/9600/4800/2400/1200 bps selectable

Items	Specifications
Control procedure	Asynchronous communication system
Communication system	Half duplex system
Character system	ASCII (8 bit)
Stop bit length	Modbus-RTU: 1 bit, CMC BUS: 2 bit
Sum check	2 byte
Parity check	None

5.3 Installation

5.3.1 Connecting the communication line

- First connect the 485 GND of MODBUS-RTU communication line to the inverter's (CM) terminals of the control terminals.
- Then connect the MODBUS-RTU communication line to the inverter's (S+), (S-) terminals of the control terminals.
- Check the connection and turn ON the inverter.
- If the communication line is connected correctly set the communication related parameters as the following:
- Operate with DriveView if DriveView is operating, if not operate with the Keypad.

DRV-03 [Drive mode] : 3(RS485)

DRV-04 [Freq. mode] : 5(RS485)

I/O-46 [Inv. Number] :1~31 (If more than 1 inverters are connected, be sure to use different numbers for each inverter)

I/O-47 [Baud-rate] : 9,600 bps (Factory default)

I/O-48 [Lost Mode] : 0 - No action (Factory default)

I/O-49 [Time-Out] : 10 – 1.0sec (Factory default)

I/O-50 [Comm.Prot] : 7 - Modbus-RTU, 0 – CMC BUS

5.3.2 System configuration

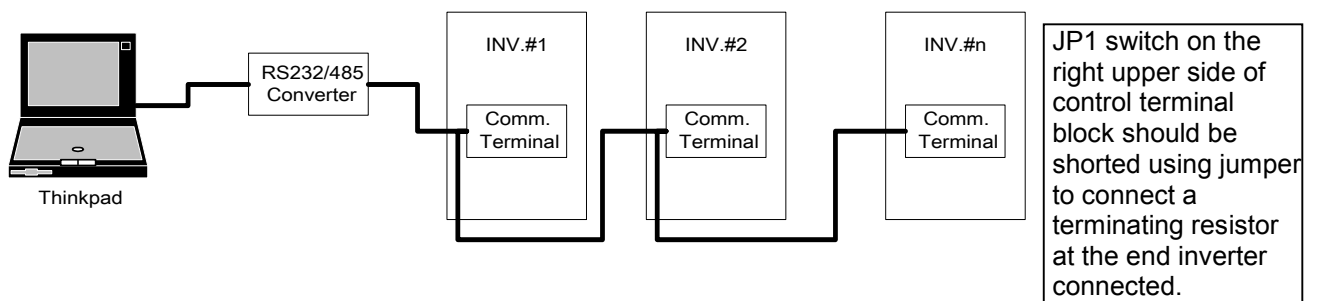

- The number of drives to be connected is up to 31 drives.
- The specification of length of communication line is max. 1200m. To ensure stable communication, limit the length below 700m.
- Use shielded wire for all control signal wiring.

5.4 Operating

5.4.1 Operating Steps

- Check whether the computer and the inverter are connected correctly.
- Turn ON the inverter. But, do not connect the load until stable communication between the computer and the inverter is verified.
- Start the operating program for the inverter from the computer.
- Operate the inverter using the operating program for the inverter.
- Refer to “6. Troubleshooting” if the communication is not operating normally.
- User program or the “DriveView” program supplied from CMC Industrial Systems can be used as the operating program for the inverter if I/O-50 [Communication Protocol Selection] was set to default value 0.

5.5 Communication Protocol (Modbus-RTU)

The communication structure is that the ACTIONMaster drives are slaves and a computer/host is the master.

5.5.1 Supported Function Code

Function Code	Name
0x03	Read Hold Register
0x04	Read Input Register
0x06	Preset Single Register
0x10	Preset Multiple Register

5.5.2 Exception Code

Exception Code	Name
0x01	ILLEGAL FUNCTION
0x02	ILLEGAL DATA ADDRESS
0x03	ILLEGAL DATA VALUE
0x06	SLAVE DEVICE BUSY

5.5.3 Baud Rate

1200, 2400, 4800, **9600**, 19200bps (default value of 9600bps)

5.6 Communication Protocol (CMC-BUS ASCII)

The communication structure is that the ACTIONMaster drives are slaves and a computer/host is the master.

5.6.1 Basic Format

Command Message (Request)

ENQ	Drive No.	CMD	Data	SUM	EOT
1 byte	2 bytes	1 byte	n bytes	2 bytes	1 byte

Normal Response (Acknowledge Response)

ACK	Drive No.	CMD	Data	SUM	EOT
1 byte	2 bytes	1 byte	n * 4 bytes	2 bytes	1 byte

Error Response (Negative Acknowledge Response)

NAK	Drive No.	CMD	Error Code	SUM	EOT
1 byte	2 bytes	1 byte	2 bytes	2 bytes	1 byte

5.6.2 Description:

- Request starts with 'ENQ' and ends with 'EOT'.
- Acknowledge Response starts with 'ACK' and ends with 'EOT'.
- Negative Acknowledge Response starts with 'NAK' and ends with 'EOT'.
- 'Drive No.' is the number of drives set in 'I/O 48'. The Drive No. is two bytes of ASCII-HEX. (ASCII-HEX: hexadecimal consists of '0' ~ '9', 'A' ~ 'F')
- 'CMD': Character letter

Character	ASCII-HEX	Command
'R'	52h	Read
'W'	57h	Write
'X'	58h	Request for monitoring
'Y'	59h	Action for monitoring

- 'Data': ASCII-HEX (Ex. When the data value is 3000 : 3000 → '0"B"B"8'h → 30h 42h 43h 38h)
- 'Error Code': ASCII (20h ~ 7Fh)
- Receive/send buffer size: Send = 39 byte, Receive=44 byte
- Monitor registration buffer: 8 Word
- 'SUM': to check the communication error.
- SUM= ASCII-HEX format of lower 8 bit of (Drive NO. + CMD + DATA)

Chapter 5 - MODBUS-RTU Communication

Example) Command Message (Request) for reading one address from address '3000'

ENQ	Drive No.	CMD	Address	The Number of address to read	SUM	EOT
05h	"01"	"R"	"3000"	"1"	"A7"	04h
1 byte	2 bytes	1 byte	4 bytes	1 byte	2 bytes	1 byte

$$\begin{aligned}
 \text{SUM} &= '0' + '1' + 'R' + '3' + '0' + '0' + '0' + '1' \\
 &= 30h + 31h + 52h + 33h + 30h + 30h + 30h + 31h \\
 &= 1A7h
 \end{aligned}$$

5.6.3 Detail Communication Protocol

- **Request for Read:** Request for read 'n' numbers of WORD from address 'XXXX'.

ENQ	Drive No.	CMD	Address	The number of address to read	SUM	EOT
05h	"01" ~ "1F"	"R"	"XXXX"	"1" ~ "8" = n	"XX"	04h
1 byte	2 bytes	1 byte	4 bytes	1 byte	2 bytes	1 byte

Total byte = 12 bytes

The quotation marks (" ") mean character.

Acknowledge Response

ACK	Drive No.	CMD	Data	SUM	EOT
06h	"01" ~ "1F"	"R"	"XXXX"	"XX"	04h
1 byte	2 bytes	1byte	N * 4 bytes	2 bytes	1 byte

Total byte = 7 * n * 4 = max. 39 bytes

Negative Acknowledge Response

NAK	Drive No.	CMD	Error Code	SUM	EOT
15h	"01" ~ "1F"	"R"	"**"	"XX"	04h
1 byte	2 bytes	1 byte	2 bytes	2 bytes	1 byte

Total byte = 9 bytes

● **Request for Write**

ENQ	Drive No.	CMD	Address	The number of address to write	Data	SUM	EOT
05h	"01" ~ "1F"	"W"	"XXXX"	"1" ~ "8" = n	"XXXX..."	"XX"	04h
1 byte	2 bytes	1 byte	4 bytes	1 byte	n * 4 bytes	2	1

Total byte = 12 + n * 4 = max. 44 bytes

Acknowledge Response

ACK	Drive No.	CMD	Data	SUM	EOT
06h	"01" ~ "1F"	"W"	"XXXX..."	"XX"	04h
1 byte	2 bytes	1 byte	n * 4 bytes	2 bytes	1 byte

Total byte = 7 + n * 4 = max. 39 bytes

Negative Acknowledge Response

NAK	Drive No.	CMD	Error Code	SUM	EOT
15h	"01" ~ "1F"	"W"	"**"	"XX"	04h
1 byte	2 bytes	1 byte	2 bytes	2 bytes	1 byte

Total byte = 9 bytes

Note) As for Run and Frequency command, when Request for Write and Acknowledge Response is exchanged between pc and inverter for the first time, previous data is returned. **In this case, Request for Write Twice.** From the second time of transmission, the exactly same data will be transmitted.

- **Request for Monitor Registration:** This is useful when constant parameter monitoring and data updates are required.

Request for Registration of 'n' numbers of Address

ENQ	Drive No.	CMD	The number of address to monitor	Address	SUM	EOT
05h	"01" ~ "	"X"	"1" ~ "	"XXXX..."	"XX"	04h
1 byte	2 bytes	1 byte	1 byte	n * 4	2 bytes	1 byte

Total byte = 8 + n * 4 = max. 40 bytes

Acknowledge Response

ACK	Drive No.	CMD	SUM	EOT
06h	"01" ~ "1F"	"X"	"XX"	04h
1 byte	2 bytes	1 byte	2 bytes	1 byte

Total byte = 7 bytes

Negative Acknowledge Response

NAK	Drive No.	CMD	Error Code	SUM	EOT
15h	"01" ~ "1F"	"X"	"**"	"XX"	04h
1 byte	2 bytes	1 byte	2 bytes	2 bytes	1 byte

Total byte = 9 bytes

- **Action Request for Monitor Registration:** Request for read of address registered by monitor registration.

ENQ	Drive No.	CMD	SUM	EOT
05h	"01" ~ "1F"	"Y"	"XX"	04h
1 byte	2 bytes	1 byte	2 bytes	1 byte

Total byte = 7 bytes

Acknowledge Response

ACK	Drive	CMD	Data	SUM	EOT
06h	"01" ~ "	"Y"	"XXXX	"XX"	04h
1 byte	2 bytes	1 byte	n * 4	2 bytes	1 byte

Total byte = 7 + n * 4 = max. 39 bytes

Negative Acknowledge Response

NAK	Drive	CMD	Error	SUM	EOT
15h	"01" ~ "	"Y"	"**"	"XX"	04h
1 byte	2 bytes	1 byte	2 bytes	2 bytes	1 byte

Total byte = 9 bytes

● Error Code

Error Code	Description
SE	Sum Error
FE	Frame Error
FC	Frame Error (Command): Not in use
FS	Frame Error (Size)
EE	Parameter EEP Access Error

5.7 Parameter Code List

< Common >

Parameter address	Description	Unit	Read/Write	Data value (HEX)	Note
0000	Inverter model	-	R	7: SV-ACTIONMaster	
0001	Inverter capacity	-	R	0: 0.5Hp, 1: 1Hp, 2: 2Hp 3: 3Hp, 4:5Hp, 5: 5.4Hp	
0002	Inverter input voltage	-	R	0: 220V class, 1:440V class	
0003	Version	-	R	313043: Version 1.0C 353043: Version 5.0C	
0004	Parameter write enable	-	R/W	0: Write disable (default) 1: Write enable	
0005	Reference frequency	0.01 Hz	R/W		
0006	Operation reference	-	R/W	Bit 0: Stop (R/W) Bit 1: Forward (R/W) Bit 2: Reverse (R/W) Bit 3: Fault reset (W) Bit 4: Emergency stop (W)	
0007	Accel time	0.1 sec	R/W		
0008	Decel time	0.1 sec	R/W		
0009	Output current	0.1 A	R		
000A	Output frequency	0.01 Hz	R		
000B	Output voltage	1 V	R		
000C	DC Link voltage				
000D	Output power				Not used
000E	Operating status	-	R	Bit 0: Stop Bit 1: Forward Bit 2: Reverse Bit 3: Fault (Trip) Bit 4: Accelerating Bit 5: Decelerating Bit 6: Speed reached Bit 7: DC Braking	
000F	Trip info	-	R	Bit 0: OC Bit 1: OV Bit 2: EXT Bit 3: BX Bit 4: LV Bit 5: Fuse Open Bit 6: GF Bit 7: OH	
0010	Input terminal info	-	R	Bit 0: FX Bit 1: RX	

Chapter 5 - MODBUS-RTU Communication

Parameter address	Description	Unit	Read/Write	Data value (HEX)	Note
				Bit 2: BX Bit 3: RST- Bit 8: P1 Bit 9: P2 Bit 10: P3	
0011	Output terminal info	-	R	Bit 0: Q1 (OC)	
0012	V1	-	R	0 – FFFF	
0013	V2	-	-		Not used
0014	I	-	R	0 – FFFF	
0015	RPM	-	R		

< DRV Group >

Parameter address(*3)	Parameter Code	Description	Default value	Max. value	Min. value	Unit	Note
6100	DRV #00	Cmd. Freq.	5000	FU1-20 (*1)	FU1-22 (*2)	0.01Hz	
6101	DRV #01	Acc. Time	100	9999	0	0.1 sec	
6102	DRV #02	Dec. Time	200	9999	0	0.1 sec	
6103	DRV #03	Drive mode	1	2	0		
6104	DRV #04	Freq. mode	2	4	0		
6105	DRV #05	Speed - 1	1000	FU1-20	0	0.01Hz	
6106	DRV #06	Speed - 2	2000	FU1-20	0	0.01Hz	
6107	DRV #07	Speed - 3	3000	FU1-20	0	0.01Hz	
6108	DRV #08	Output Current	0	-	-	0.1A	Read Only
6109	DRV #09	Output speed	0	-	-	RPM	Read Only
610A	DRV #10	DC Link Voltage	0	-	-	0.1V	Read Only

(*1) Refer to FU1 #20 for Max Freq.

(*2) Refer to FU1 #22 for Start Freq.

(*3) Parameter address is HEX data

< FU1 Group >

Parameter address	Parameter Code	Description	Default value	Max. value	Min. value	Unit	Note
6203	FU1 #03	Run prohibit	0	2	0		
6205	FU1 #05	Acc. pattern	0	4	0		
6206	FU1 #06	Dec. pattern	0	4	0		
6207	FU1 #07	Stop mode	0	2	0		
6208	FU1 #08	DcBr freq.	500	5000	FU1-22	0.01 Hz	
6209	FU1 #09	DcBlk time	10	6000	0	0.01 sec	
620A	FU1 #10	DcBr value	50	200	0	1%	
620B	FU1 #11	DcBr time	10	600	0	0.1sec	

Parameter address	Parameter Code	Description	Default value	Max. value	Min. value	Unit	Note
620C	FU1 #12	DcSt value	50	200	0	1%	
620D	FU1 #13	DcSt time	0	600	0	0.1sec	
6214	FU1 #20	Max freq.	5000	40000	4000	0.01Hz	
6215	FU1 #21	Base freq.	5000	FU1-20	3000	0.01Hz	
6216	FU1 #22	Start freq.	10	1000	10	0.01Hz	
6217	FU1 #23	Freq limit	0	1	0		
6218	FU1 #24	F-limit Lo.	0	FU1-25	0	0.01Hz	
6219	FU1 #25	F-limit Hi.	5000	FU1-20	FU1-24	0.01Hz	
621A	FU1 #26	Torque boost	0	1	0		
621B	FU1 #27	Fwd boost	50	150	0	0.1%	
621C	FU1 #28	Rev boost	50	150	0	0.1%	
621D	FU1 #29	V/F pattern	0	2	0		
621E	FU1 #30	User freq. 1	1250	FU1-32	0	0.01Hz	
621F	FU1 #31	User volt. 1	25	100	0	%	
6220	FU1 #32	User freq. 2	2500	FU1-34	FU1-30	0.01Hz	
6221	FU1 #33	User volt. 2	50	100	0	%	
6222	FU1 #34	User freq. 3	3750	FU1-36	FU1-32	0.01Hz	
6223	FU1 #35	User volt. 3	75	100	0	%	
6224	FU1 #36	User freq. 4	5000	FU1-20	FU1-34	0.01Hz	
6225	FU1 #37	User volt. 4	100	100	0	%	
6226	FU1 #38	Volt control	1000	1100	40	%	
6227	FU1 #39	Energy save	0	30	0	%	
6232	FU1 #50	ETH select	0	1	0		
6233	FU1 #51	ethperc	180	250	FU1-52	%	
6234	FU1 #52	contperc	120	FU1-51	50	%	
6235	FU1 #53	Motor type	0	1	0		
6236	FU1 #54	OL level	150	250	30	%	
6237	FU1 #55	OL time	100	300	0	0.1sec	
6238	FU1 #56	OLT select	0	1	0		
6239	FU1 #57	OLT level	200	250	30	%	
623A	FU1 #58	OLT time	600	600	0	0.1sec	
623B	FU1 #59	Stall prev.	0	7	0		
623C	FU1 #60	Stall level	200	250	30	%	

Chapter 5 - MODBUS-RTU Communication

< FU2 Group >

Parameter address	Parameter Code	Description	Default value	Max. value	Min value	Unit	Note
630A	FU2 #10	Jump freq	0	1	0		
630B	FU2 #11	Jump lo 1	0	FU2-12	0	0.01Hz	
630C	FU2#12	Jump Hi 1	0	FU1-20	FU2-11	0.01Hz	
630D	FU2 #13	Jump lo 2	0	FU2-14	0	0.01Hz	
630E	FU2 #14	jump Hi 2	0	FU1-20	FU2-13	0.01Hz	
630F	FU2 #15	jump lo 3	0	FU2-16	0	0.01Hz	
6310	FU2 #16	jump Hi 3	0	FU1-20	FU2-15	0.01Hz	
6314	FU2 #20	Power-on run	0	1	0		
6315	FU2 #21	RST restart	0	1	0		
6316	FU2 #22	ssMode	0000	1111	0000		
6317	FU2 #23	ssStallPerc	180	200	80	%	
6318	FU2 #24	SS P-Gain	100	9999	0		
6319	FU2 #25	SS I-Gain	1000	9999	0		
631A	FU2 #26	Retry number	0	10	0		
631B	FU2 #27	Retry delay	10	600	0	0.1sec	
631E	FU2 #30	Motor select	*	5	0		
631F	FU2 #31	Pole number	4	12	2		
6320	FU2 #32	Rated-Slip	*	1000	0	0.01Hz	
6321	FU2 #33	Rated-Curr	*	999	1	0.1A	
6322	FU2 #34	Noload-Curr	*	999	1	0.1A	
6324	FU2 #36	Efficiency	*	100	50	%	
6325	FU2 #37	Inertiarate	0	2	0		
6327	FU2 #39	Carrier freq	30	100	10	0.1kHz	
6328	FU2 #40	Control mode	0	2	0		
6332	FU2 #50	PID F/B	0	1	0		
6333	FU2 #51	PID P-gain	3000	9999	0		
6334	FU2 #52	PID I-time	300	9999	0		
6335	FU2 #53	PID D-time	0	9999	0		
6336	FU2 #54	PID limit	5000	FU1-20	0	0.01Hz	
6346	FU2 #70	Acc/Dec freq	0	1	0		
6347	FU2 #71	Time scale	1	2	0		
6348	FU2 #72	PowerOn disp	0	13	0		
6349	FU2 #73	User disp	0	2	0		
634A	FU2 #74	RPM factor	100	1000	1	%	
634B	FU2#75	DB Mode	2	2	0		
634C	FU2#76	DB % ED	10	30	0	%	
634F	FU2 #79	S/W version					
6351	FU2 #81	2nd Acc time	50	9999	0	0.1sec	
6352	FU2 #82	2nd Dec time	100	9999	0	0.1sec	
6353	FU2 #83	2nd BaseFreq	5000	FU1-20	3000	0.01Hz	

Parameter address	Parameter Code	Description	Default value	Max. value	Min value	Unit	Note
6354	FU2 #84	2nd V/F	0	2	0		
6355	FU2 #85	2nd F-boost	20	150	0	0.1%	
6356	FU2 #86	2nd R-boost	20	150	0	0.1%	
6357	FU2 #87	2nd Stall	200	250	30	%	
6358	FU2 #88	2nd ETH	180	250	FU2-89	%	
6359	FU2 #89	2nd ETH	120	FU2-88	50	%	
635A	FU2 #90	2nd R-Curr	18	999	1	0.1A	

(*1), (*2), (*3) values vary according to the capacity.

< I/O Group >

Parameter address	Parameter Code	Description	Default value	Max. value	Min value	Unit	Note
6401	I/O #01	V1 filter	100	9999	0	ms	
6402	I/O #02	V1 volt x1	0	IO-04	0	0.01V	
6403	I/O #03	V1 freq y1	0	FU1-20	0	0.01Hz	
6404	I/O #04	V1 volt x2	1000	1200	IO-02	0.01V	
6405	I/O #05	V1 freq y2	5000	FU1-20	0	0.01Hz	
6406	I/O #06	I filter	100	9999	0	ms	
6407	I/O #07	I curr x1	400	IO-09	0	0.01 mA	
6408	I/O #08	I freq y1	0	FU1-20	0	0.01 Hz	
6409	I/O #09	I curr x2	2000	2400	IO-07	0.01 mA	
640A	I/O #10	I freq y2	5000	FU1-20	0	0.01 Hz	
640B	I/O #11	Wire broken	0	2	0		
640C	I/O #12	P1 define	0	26	0		
640D	I/O #13	P2 define	1	26	0		
640E	I/O #14	P3 define	2	26	0		
640F	I/O #15	In Status					
6410	I/O #16	Out Status					
6411	I/O #17	TI Filt Num	2	20	2		
6414	I/O #20	Jog freq	1000	FU1-20	0	0.01 Hz	
6415	I/O #21	Speed - 4	4000	FU1-20	0	0.01 Hz	
6416	I/O #22	Speed - 5	5000	FU1-20	0	0.01 Hz	
6417	I/O #23	Speed - 6	4000	FU1-20	0	0.01 Hz	
6418	I/O #24	Speed - 7	3000	FU1-20	0	0.01 Hz	
6419	I/O #25	Acc - 1	200	9999	0	0.1 sec	
641A	I/O #26	Dec - 1	200	9999	0	0.1 sec	
641B	I/O #27	Acc - 2	300	9999	0	0.1 sec	
641C	I/O #28	Dec - 2	300	9999	0	0.1 sec	
641D	I/O #29	Acc - 3	400	9999	0	0.1 sec	
641E	I/O #30	Dec - 3	400	9999	0	0.1 sec	
641F	I/O #31	Acc - 4	500	9999	0	0.1 sec	

Chapter 5 - MODBUS-RTU Communication

Parameter address	Parameter Code	Description	Default value	Max. value	Min value	Unit	Note
6420	I/O #32	Dec – 4	500	9999	0	0.1 sec	
6421	I/O #33	Acc – 5	400	9999	0	0.1 sec	
6422	I/O #34	Dec – 5	400	9999	0	0.1 sec	
6423	I/O #35	Acc – 6	300	9999	0	0.1 sec	
6424	I/O #36	Dec – 6	300	9999	0	0.1 sec	
6425	I/O #37	Acc – 7	200	9999	0	0.1 sec	
6426	I/O #38	Dec – 7	200	9999	0	0.1 sec	
6428	I/O #40	FM mode	0	3	0		
6429	I/O #41	FM adjust	100	200	10	%	
642A	I/O #42	FDT freq	3000	FU1-20	0	0.01 Hz	
642B	I/O #43	FDT band	1000	FU1-20	0	0.01 Hz	
642C	I/O #44	Aux mode	12	20	0		
642D	I/O #45	Relay mode	2	7	0	BIT3	
642E	I/O #46	Inv. no	1	31	1		
642F	I/O #47	Baud rate	3	4	0		
6430	I/O #48	Lost command	0	2	0		
6431	I/O #49	Time out	10	1200	1	0.1 sec	
6432	I/O #50	Comm. Prot	7	7	0		

5.8 Troubleshooting

Refer to this chapter when a trouble is occurred.

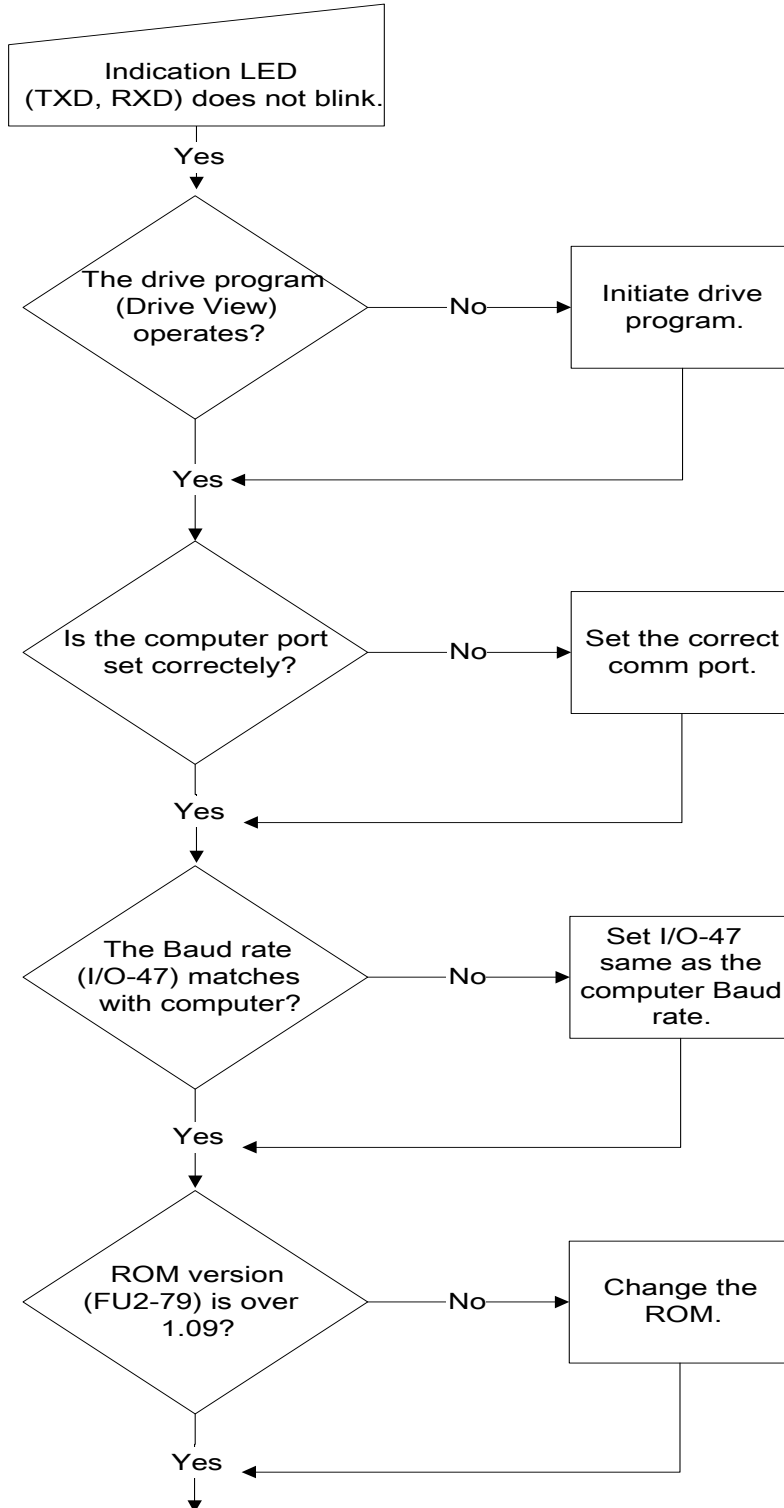

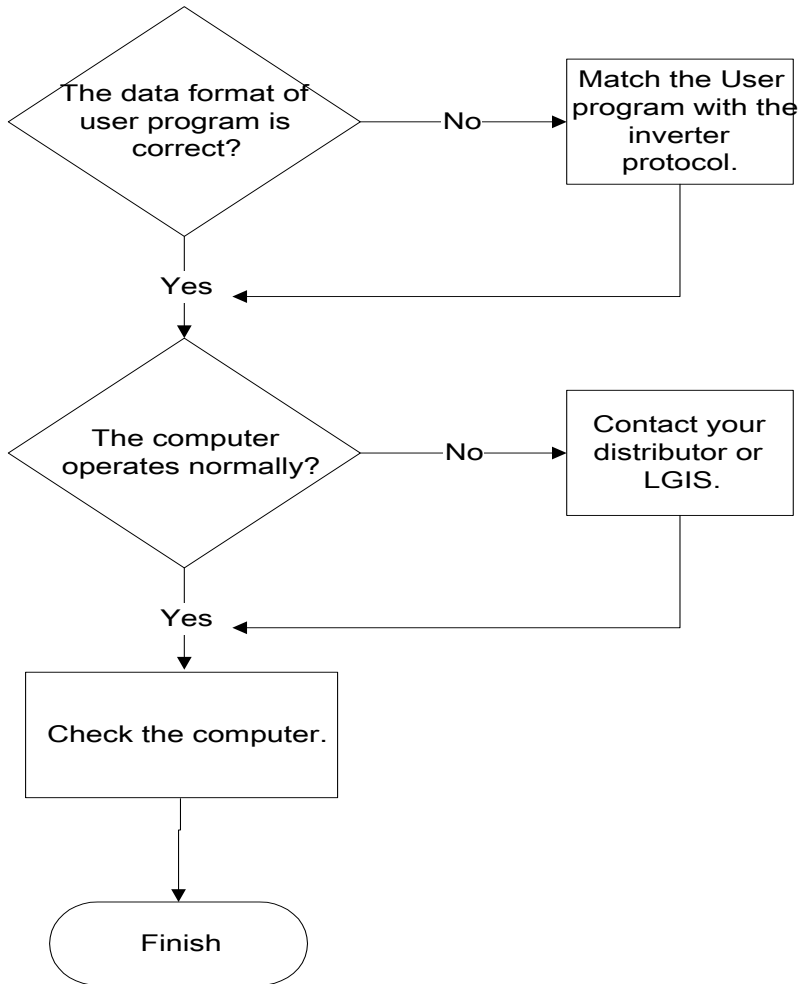

5.9 ASCII Code List

Character	Hex	Character	Hex	Character	Hex
A	41	q	71	@	40
B	42	r	72	[5B
C	43	s	73	\	5C
D	44	t	74]	5D
E	45	u	75		5E
F	46	v	76		5F
G	47	w	77		60
H	48	x	78	{	7B
I	49	y	79		7C
J	4A	z	7A	}	7D
K	4B	0	30	~	7E
L	4C	1	31	BEL	07
M	4D	2	32	BS	08
N	4E	3	33	CAN	18
O	4F	4	34	CR	0D
P	50	5	35	DC1	11
Q	51	6	36	DC2	12
R	52	7	37	DC3	13
S	53	8	38	DC4	14
T	54	9	39	DEL	7F
U	55	space	20	DLE	10
V	56	!	21	EM	19
W	57	"	22	ACK	06
X	58	#	23	ENQ	05
Y	59	\$	24	EOT	04
Z	5A	%	25	ESC	1B
a	61	&	26	ETB	17
b	62	'	27	ETX	03
c	63	(28	FF	0C
d	64)	29	FS	1C
e	65	*	2A	GS	1D
f	66	+	2B	HT	09
g	67	,	2C	LF	0A
h	68	-	2D	NAK	15
i	69	.	2E	NUL	00
j	6A	/	2F	RS	1E
k	6B	:	3A	S1	0F
l	6C	;	3B	SO	0E
m	6D	<	3C	SOH	01
n	6E	=	3D	STX	02
o	6F	>	3E	SUB	1A
p	70	?	3F	SYN	16
				US	1F
				VT	0B

CHAPTER 6 - TROUBLESHOOTING & MAINTENANCE

6.1 Fault Display

When a fault occurs, the inverter turns off its output and displays the fault status in DRV-07. The last 5 faults are saved in FU2-01 through FU2-05 with the operation status at the instance of fault.

Display	Protective Function	Description
OC	Over Current Protection	The inverter turns off its output when the output current of the inverter flows more than 200% of the inverter rated current.
OV	Over Voltage protection	The inverter turns off its output if the DC voltage of the main circuit increases higher than the rated value when the motor decelerates or when regenerative energy flows back to the inverter due to a regenerative load. This fault can also occur due to a surge voltage generated at the power supply system.
OLT	Current Limit Protection (Overload Protection)	The inverter turns off its output if the output current of the inverter flows at 180% of the inverter rated current for more than the current limit time (S/W).
OH	Heat Sink Over Heat	The inverter turns off its output if the heat sink over heats due to a damaged cooling fan or an alien substance in the cooling fan by detecting the temperature of the heat sink.
ETH	Electronic Thermal	The internal electronic thermal of the inverter determines the over heating of the motor. If the motor is overloaded the inverter turns off the output. The inverter cannot protect the motor when driving a multi-pole motor or when driving multiple motors, so consider thermal relays or other thermal protective devices for each motor. Overload capacity: 150% for 1 min
LV	Low Voltage Protection	The inverter turns off its output if the DC voltage is below the detection level. Insufficient torque or over heating of the motor can occurs when the input voltage of the inverter drops.
COL	Input Phase Open	The inverter turns off the output when one or more of the input(R, S, T) phase is open and the output load is over 50% of the inverter rated current for more than 1 minute. The inverter checks whether the phase is open by detecting the DC voltage of the main circuit.
OP0	Output Phase Open	The inverter turns off its output when the one or more of the output (U, V, W) phase is open. The inverter detects the output current to check the phase open of the output.
b4	BX Protection (Instant Cut Off)	Used for the emergency stop of the inverter. The inverter instantly turns off the output when the BX terminal is turned ON, and returns to regular operation when the BX terminal is turned OFF. Take caution when using this function.
1OLT	Inverter Overload	The inverter turns off its output when the output current of the inverter flows more than the rated level (150% for 1 minute-Inversely proportional to time).
E4tA	External Fault A	Use this function if the user needs to turn off the output by an external fault signal. (Normal Open Contact)
E4tB	External Fault B	Use this function if the user needs to turn off the output by an external fault signal. (Normal Close Contact)
---	Operating Method when the Frequency Reference is Lost	According to I/O-48 [Operating Method when the Frequency Reference is Lost], there are 3 modes: continue operation, decelerate and stop, and free run.

Display	Protective Function	Description
EO1	EEPROM Error 1	The keypad EEPROM has a fault causing parameter read/write error.
EO2	EEPROM Error 2	The ROM version for the inverter and keypad are different.
HW	Inverter H/W Fault	When an error occurs to the control circuitry of the inverter a fault signal is sent. There are the CPU error, the EEP error, Fan Fault, Ground Fault and NTC Damage for this fault
CPU2	CPU Error	The CPU has a fault.
EEP	EEP Error	The EEPROM on inverter main board has a fault.
FAN	Fan fault	The cooling fan does not rotate.
GF	Ground Fault	A ground fault occurs. Inverter checks ground fault only when power is ON and run command is entered.
NTC	NTC Damage	NTC is damaged.

Note: "HW" is displayed when "FAN", "EEP", "CPU2", "GF", or "NTC" faults occur. Use "FUNC", "UP", "UP", "UP" keys to see the detailed fault contents.



CAUTION

Inverter outputs voltage for 20msec to check Ground Fault.

6.1.1 Operating Method and Fault Display when Frequency Reference is Lost

■ I/O-48 [Operating Method when Frequency Reference is Lost]

I/O-48 Setting	Function Description
0 (None)	Continues operation when the frequency reference is lost (Factory Default)
1 (FreeRun)	Free runs and stops when the frequency reference is lost.
2 (Stop)	Decelerates and stops when the frequency reference is lost.

■ Keypad Display when Analog Frequency Reference is Lost

Keypad Display	Contents
___L	Displayed when V1 analog frequency reference is lost.
___L	Displayed when I analog frequency reference is lost.

■ Fault Contents and Operating Status Prior to Fault

1) Present Fault Contents (Ex: Over Current)

Code	Display	Description
DRV-7	OC	Displays the present fault contents (Over current)

Check the fault contents before pressing the reset key. Press the [FUNC] key and then use the [↑(Up)], [↓(Down)] keys to check the operating information (output frequency, output current, acceleration, deceleration, constant speed status) prior to fault. Press the [FUNC] key to exit. The inverter will store the

Chapter 6 - Troubleshooting & Maintenance

fault contents to the memory in FU2-1 when the [RESET] key is pressed.

2) Fault History Contents

FU2-1~5 [Fault history] has the 5 most current faults in its memory. The smallest number will be the most current fault in its memory. Check the operating information prior to fault.

Code	Display	Description
FU2-1	Last trip-1	Fault history 1
FU2-2	Last trip-2	Fault history 2
FU2-3	Last trip-3	Fault history 3
FU2-4	Last trip-4	Fault history 4
FU2-5	Last trip-5	Fault history 5

The FU2-6 [Erase Fault History] erases FU2-1~5 [Fault History] contents from the memory, and returns the contents to the factory default status.

6.2 Fault (Inverter Fault) Reset

There are 3 ways to reset the inverter. The auto retry number will be initialized when the user resets the inverter.

- 1) Reset by using the [STOP/RESET] key of the keypad.
- 2) Reset by shorting the RST-CM terminals on the control terminals.
- 3) Turn OFF the inverter and turn the inverter back ON.

6.3 Fault Remedy

Protective Function	Cause	Remedy
Over Current Protection	<ol style="list-style-type: none"> 1) Acceleration/Deceleration time is too short compared to the GD^2 of the load. 2) Load is larger than the inverter rating. 3) Inverter turns output on while motor is free running. 4) Output short or ground fault has occurred. 5) Mechanical brake of the motor is operating too fast. 6) Components of the main circuit have overheated due to a faulty cooling fan. 	<ol style="list-style-type: none"> 1) Increase Accel/Decel time. 2) Increase inverter capacity. 3) Operate after motor has stopped. 4) Check output wiring. 5) Check mechanical brake operation. 6) Check cooling fan. <p>(Caution) Operating prior to correcting fault may damage the IGBT.</p>
Over Voltage Protection	<ol style="list-style-type: none"> 1) Deceleration time is too short compared to the GD^2 of the load. 2) Regenerative load on inverter output. 3) Line voltage is too high. 	<ol style="list-style-type: none"> 1) Increase deceleration time. 2) Use regenerative resistor option. 3) Check line voltage.
Current Limit Protection (Overload Protection)	<ol style="list-style-type: none"> 1) Load is larger than inverter rating. 2) User selected incorrect inverter capacity. 3) User set incorrect V/F pattern. 	<ol style="list-style-type: none"> 1) Increase capacity of motor and inverter. 2) Select a correct inverter capacity. 3) Select correct V/F pattern.
Heat Sink Overheat	<ol style="list-style-type: none"> 1) Cooling fan is damaged or an alien substance is inserted. 2) Cooling system has faulted. 3) Ambient temperature too high. 	<ol style="list-style-type: none"> 1) Exchange cooling fans and/or eliminate alien substance. 2) Check for any alien substances in heat sink. 3) Keep ambient temperature under 40 °C (104 °F).
Electronic Thermal	<ol style="list-style-type: none"> 1) Motor has overheated. 2) Load is larger than inverter rating. 3) ETH level too low. 4) User selected incorrect inverter capacity. 5) User set incorrect V/F pattern. 6) Operating too long at low speeds. 	<ol style="list-style-type: none"> 1) Reduce load and/or running duty. 2) Increase inverter capacity. 3) Adjust ETH level to an appropriate level. 4) Select a correct inverter capacity. 5) Select a correct V/F pattern. 6) Install a cooling fan with a separate blower.
Low Voltage Protection	<ol style="list-style-type: none"> 1) Line voltage too low. 2) Load larger than line capacity connected to input. (Welding machine, motor with high starting current connected to the commercial line) 3) Damaged or faulty magnetic switch at input side of inverter. 	<ol style="list-style-type: none"> 1) Check line voltage. 2) Increase line capacity. 3) Exchange magnetic switch.
Output Phase Open	<ol style="list-style-type: none"> 1) Faulty contact on the magnetic switch at the output. 2) Faulty output wiring 	<ol style="list-style-type: none"> 1) Check magnetic switch on output. 2) Check output wiring.
H/W Fault	<ol style="list-style-type: none"> 1) Fan Fault 2) CPU Error 3) EEPROM Error 4) Ground Fault 5) NTC Damage 	<ol style="list-style-type: none"> 1) Check cooling fan. 2) Exchange inverter. 3) Exchange inverter. 4) Check inverter, motor, and wiring insulation. 5) Check NTC.
LOV (V1) LOI (I)	Frequency Reference is Lost	Eliminate cause of fault.
Inverter Overload	<ol style="list-style-type: none"> 1) Load is larger than inverter rating. 2) User selected incorrect inverter capacity. 	<ol style="list-style-type: none"> 1) Increase motor and/or inverter capacity. 2) Select correct inverter capacity.

6.4 Troubleshooting

Condition	Check Point
The motor does not rotate	<ol style="list-style-type: none"> 1) Main circuit inspection <ul style="list-style-type: none"> ☞ Input (line) voltage normal? (LED charge lamp on?) ☞ Motor connected correctly? 2) Input signal inspection <ul style="list-style-type: none"> ☞ Input signal to inverter functioning? ☞ Forward and reverse signals inputted simultaneously to inverter? ☞ Inverter receiving command input frequency signal? 3) Parameter setting inspection <ul style="list-style-type: none"> ☞ Reverse prevention (FU1-03) function set? ☞ Operation mode (FU1-01) set correctly? ☞ Command frequency set to 0? 4) Load inspection <ul style="list-style-type: none"> ☞ Load too large, or motor restrained. (Mechanical Brake) 5) Other <ul style="list-style-type: none"> ☞ Alarm displayed on keypad, or alarm LED lit? (STOP LED blinking?)
The motor rotates in opposite directions	<ul style="list-style-type: none"> ☞ Phase sequence of output terminal U, V and W correct? ☞ Starting signal (Forward/Reverse) connected correctly?
The difference between the rotating speed and the reference is too big	<ul style="list-style-type: none"> ☞ Reference frequency verified? (Check the level of input signal) ☞ Following parameter setting verified? Lower Limit Frequency (FU1-24), Upper Limit Frequency (FU1-25), Analog Frequency Gain (I/O-1~10) ☞ External noise? (Use a shielded wire)
The inverter does not accelerate or decelerate smoothly	<ul style="list-style-type: none"> ☞ Acceleration/Deceleration time too short. ☞ Load too large? ☞ Torque Boost (FU1-27, 28) value too high? (Current limit function and the stall prevention function verified?)
The motor current is too high	<ul style="list-style-type: none"> ☞ Load too large? ☞ Torque Boost Value (manual) too high?
The rotating speed does not increase	<ul style="list-style-type: none"> ☞ Upper Limit Frequency (FU1-25) value correct? ☞ Load too large? ☞ Torque Boost (FU1-27, 28) value too high? Is Stall prevention function (FU1-59, 60) verified?
The rotating speed oscillates when the inverter is operating.	<ol style="list-style-type: none"> 1) Load inspection <ul style="list-style-type: none"> ☞ Load oscillating? 2) Input signal inspection <ul style="list-style-type: none"> ☞ Reference frequency signal oscillating? 3) Other <ul style="list-style-type: none"> ☞ Wiring too long? (Over 500m, 1,500ft)

6.5 How to Check Power Components

Before checking the power components, be sure to disconnect AC Input supply and wait until the Main Electrolytic Capacitors (DCP-DCN) are discharged to safe voltage levels.

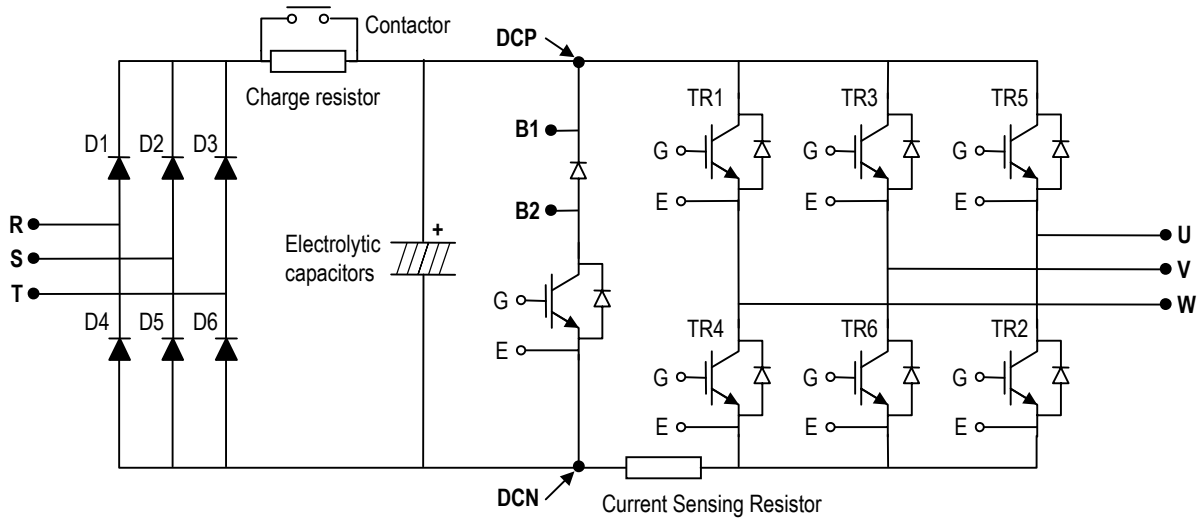

- 1) Disconnect the power input line (R, S, T) and the inverter output to the motor (U, V, W).
- 2) Verify whether the inverter terminal R, S, T, U, V, W, B1, B2 is shorted or open by changing the polarity of the tester.
- 3) Verify capacitor has discharged before testing.
- 4) The tester should display several mega-ohms when open. The tester can display terminal is shorted for a short time and then display several mega-ohms because of the electrolytic capacitor. The tester should display 1 Ω ~ 10 Ω when terminal is shorted. If all measured values are about the same, individual modules are OK.
- 4) Diode module and IGBT module checking points:

Elements		Test Polarity		Measured Value	Element	Test Polarity		Measured Value
		+	-			+	-	
Diode Module	D1	R	B1	Short	D4	R	DCN	Open
		B1	R	Open		DCN	R	Short
	D2	S	B1	Short	D5	S	DCN	Open
		B1	S	Open		DCN	S	Short
	D3	T	B1	Short	D6	T	DCN	Open
		B1	T	Open		DCN	T	Short
IGBT Module	Tr1	U	B1	Short	Tr4	U	DCN	Open
		B1	U	Open		DCN	U	Short
	Tr3	V	B1	Short	Tr6	V	DCN	Open
		B1	V	Open		DCN	V	Short
	Tr5	W	B1	Short	Tr2	W	DCN	Open
		B1	W	Open		DCN	W	Short

6.6 Maintenance

The ACtionMaster series is an industrial electronic product with advanced semiconductor components, however temperature, humidity, vibration and eventually aging parts may still affect it. To avoid this, it is recommended to perform routine inspections.

6.6.1 Precautions

- Be sure to remove the drive power input while performing maintenance.
- Be sure to perform maintenance only after checking that the DC bus has discharged. The bus capacitors in the electronic circuit can still be charged even after the power is turned off.
- The correct output voltage can only be measured by using a rectifier voltage meter. Other voltage meters including digital voltage meters are likely to display incorrect values caused by the high frequency PWM output voltage of the drive.

6.6.2 Routine Inspection

Be sure to check the following before operation.

- The conditions of the installation location.
- The conditions of the drive cooling.
- Abnormal vibration.
- Abnormal heating.

6.6.3 Periodical Inspection

- Any loose bolt, nut or rust caused by surrounding conditions? If so, tighten up or replace.
- Any deposits inside of the drive or cooling fan? If so, remove the deposits using air.
- Any deposit on the drive's PCB (Printed Circuit Boards)? If so, remove the deposits using air.
- Any abnormal contacts in the various connectors of the drive's PCB? If so, check the condition of the connector in question.
- Check the rotating condition of the cooling fan, the size and condition of the capacitors and the connections with the magnetic contactor. Replace it if there is any abnormality.

6.7 Daily and Periodic Inspection Items

Inspection Location	Inspection Item	Inspection	Period			Inspection Method	Criterion	Measuring Instrument
			Daily	1 year	2 year			
All	Ambient Environment	Is there any dust? Is the ambient temperature and humidity adequate?	O			Refer to the precautions	Temperature: -10~+40 no freezing. Humidity: Under 90% no dew	Thermometer, Hygrometer, Recorder
	Equipment	Is there any abnormal oscillation or noise	O			Use sight and hearing	No abnormality	
	Input Voltage	Is the input voltage of the main circuit normal	O			Measure the voltage between the terminals R, S, T		Digital Multi-Meter/Tester
Main Circuit	All	Megger check (between the main circuit and the ground) Are any fixed parts removed? Are there any traces of overheating at each component's cleaning?		O	O	Undo the inverter connections short the terminals R, S, T, U, V, W and measure between these parts and the ground. Tighten the screws. Visual check.	Over 5M Ω No fault	DC 500V class Megger
	Conductor/Wire	Is the conductor rusty? Is the wire coating damaged?		O		Visual check	No fault	
	Terminal	Is there any damage?		O		Visual check	No fault	
	IGBT Module /Diode Module	Check the resistance between each of the terminals.			O	Undo the inverter connection and measure the resistance between R, S, T ↔ P, N and U, V, W ↔ P, N with a tester.	(Refer 'How to Check Power Components')	Digital Multi-Meter/Analog Tester
	Smoothing Capacitor	Is there any liquid coming out? Is the safety pin out, and is there any swelling? Measure the capacitance.	O		O	Visual check. Measure with a capacitance-measuring device.	No fault Over 85% of the rated capacity	Capacitance Measuring Device
	Relay	Is there any chattering noise during operation? Is there any damage to the contact			O	Auditory check. Visual check.	No fault	
	Resistor	Is there any damage to the resistor insulation? Is the wiring in the resistor damaged (open)?			O	Visual check. Disconnect one of the connections and measure with a tester.	No fault Error must be within ±10% the displayed resistance	Digital Multi-Meter/Analog Tester
Control Circuit Protective Circuit	Operation Check	Is there any unbalance between each phases of the output voltage? Nothing must be wrong with display circuit after executing the sequence protective operation		O	O	Measure the voltage between the output terminals U, V and W. Short and open the inverter protective circuit output.	The voltage balance between the phases for 200V (800V) class is under 4V (8V). The fault circuit operates according to the sequence.	Digital Multi-Meter/Rectifying Voltmeter

Chapter 6 - Troubleshooting & Maintenance

Inspection Location	Inspection Item	Inspection	Period			Inspection Method	Criterion	Measuring Instrument
			Daily	1 year	2 year			
Cooling System	Cooling Fan	Is there any abnormal oscillation or noise? Is the connection area loose?	○	○		Turn OFF the power and turn the fan by hand. Tighten the connections.	Must rotate smoothly. No fault	
Display	Meter	Is the displayed value correct?	○	○		Check the meter reading at the exterior of the panel	Check the specified and management values.	Voltmeter/ Ammeter etc.
Motor	All	Are there any abnormal vibrations or noise? Is there any unusual odor?	○ ○			Auditory, sensory, visual check. Check for overheat and damage.	No fault	
	Insulation Resistor	Megger check (between the output terminals and the ground terminal)			○	Undo the U, V and W connections and tie the motor wiring.	Over 5M Ω	500V class Megger

Note: Values in () are for the 400V class inverters.

Notes:

CHAPTER 7 - OPTIONS

7.1 Braking Resistor

Braking resistor is optional.

7.1.1 Lower Braking Magnitude

Model Number SvxxxActionMaster -x		004-1/2	008-1/2	015-1/2	022-2	037-2 040-2	004-4	008-4	015-4	022-4	037-4 040-4
Duty	Enable Duty [%]	5	5	3	2	2	5	5	3	2	2
	Continuous Braking Time [Sec]	5	5	5	5	5	5	5	5	5	5
Resistor	Resistor Value [Ω]	400	200	100	60	40	1800	900	450	300	200
	Resistor Capacity [W]	100	100	100	100	100	100	100	100	100	100

7.1.2 Higher Braking Magnitude

[200V Class]

Model Number SvxxxActionMaster -x		004-1/2		008-1/2		015-2/1		022-2		037-2 040-2	
Average Braking Torque [%]		100	150	100	150	100	150	100	150	100	150
Duty	Enable Duty [%]	5	5	5	5	5	5	5	5	5	5
	Continuous Braking Time [Sec]	5	5	5	5	5	5	5	5	5	5
Resistor	Resistor Value [Ω]	400	300	200	150	100	60	60	50	40	33
	Resistor Capacity [W]	100	150	100	150	200	300	300	400	600	600

[400V Class]

Model Number SvxxxActionMaster -x		004-4		008-4		015-4		022-4		037-4 040-4	
Average Braking Torque [%]		100	150	100	150	100	150	100	150	100	150
Duty	Enable Duty [%]	5	5	5	5	5	5	5	5	5	5
	Continuous Braking Time [Sec]	5	5	5	5	5	5	5	5	5	5
Resistor	Resistor Value [Ω]	400	300	900	600	450	300	300	200	200	130
	Resistor Capacity [W]	100	150	100	150	200	300	300	400	500	600

7.1.3 Braking resistor wiring diagram

Wire the braking resistor to the inverter as short as possible.

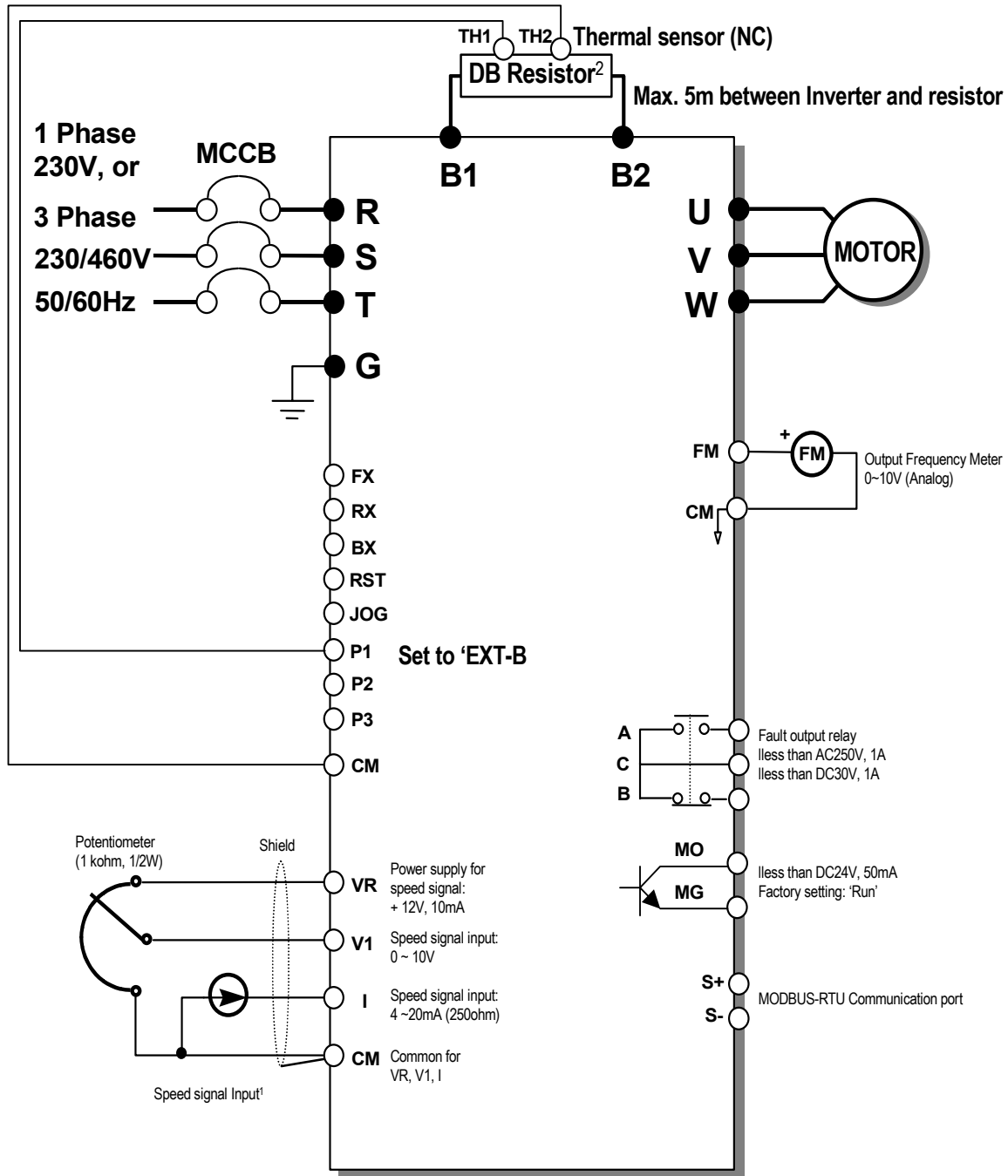

- Note) 1. Analog speed command can be set by Voltage, Current and both of them.
 2. DB resistor is optional.

7.2 DIN Rail Base

Unit: mm

SV004ActionMaster -1/2
SV008ActionMaster -2

SV008ActionMaster -1
SV015ActionMaster -

2

SV004/008/015ActionMaster -4

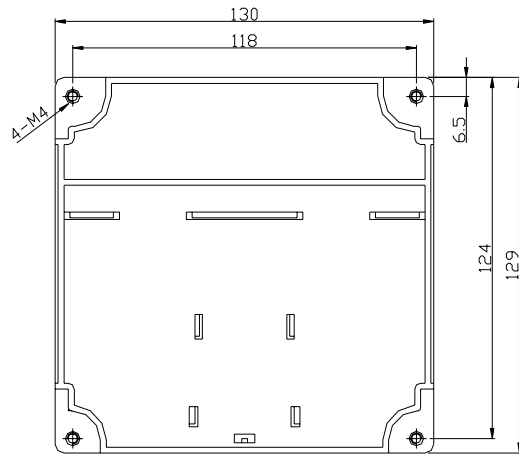
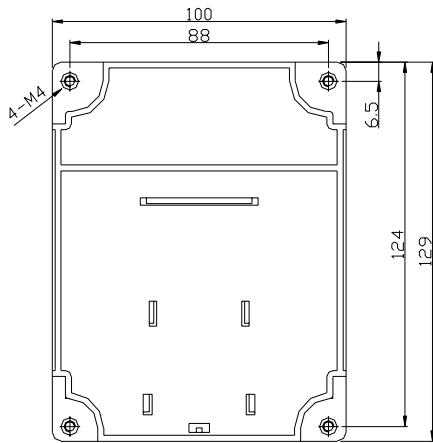

SV015ActionMaster -1
SV022/037/040ActionMaster -2/4

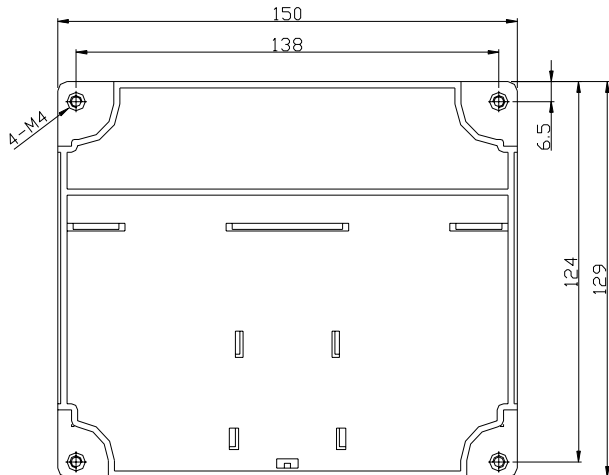

Notes:

APPENDIX A - FUNCTIONS BASED ON THE USE

Set the function properly according to the load and operating conditions. The application and the related functions are listed at the following table.

Use	Related Parameter Code
Accel/Decel time, pattern adjustment	DRV-01 [Acceleration Time], DRV-02 [Deceleration Time], FU1-05 [Acceleration Pattern], FU1-06 [Deceleration Pattern]
Reverse rotation prevention	FU1-03 [Forward, Reverse Prevention]
Minimum time Accel/Decel	FU1-05 [Acceleration Pattern], FU1-06 [Deceleration Pattern]
Accel/Decel at continuous rating range	FU1-05 [Acceleration Pattern], FU1-06 [Deceleration Pattern]
Braking operation adjustment	FU1-07 [Stop Method], FU1-08~11 [DC Braking], FU1-12~13 [DC braking at Start]
Operations for frequencies over 50 Hz	FU1-20 [Maximum Frequency], FU1-25 [Frequency Upper Limit], I/O-05 [Frequency Corresponding to Max. Voltage of V1], I/O-10 [Frequency Corresponding to Max. Current of I]
Selecting an appropriate output characteristics for the load	FU1-20 [Maximum Frequency], FU1-21 [Base Frequency]
Motor output torque adjustment	FU1-22 [Starting Frequency], FU1-26~28 [Torque Boost], FU1-59~60 [Stall Prevention], FU2-30 [Rated Motor]
Output frequency limit	FU1-23~25 [Frequency Upper/Lower Limit], I/O-01~10 [Analog Frequency Setting]
Motor Overheat protection	FU1-50~53 [Electronic Thermal], FU2-30 [Rated Motor]
Multi step operation	I/O-12~14 [Define the Multi Function Input Terminals], I/O-20~27 [Jog, Multi Step Frequency], FU1-23~25 [Frequency Upper/Lower Limit]
Jog Operation	I/O-20 [Jog Frequency]
Frequency Jump Operation	FU2-10~16 [Frequency Jump]
Timing the electronic brake operation	I/O-42~43 [Frequency Detection Level], I/O-44 [Multi Function Output]
Displaying the rotating speed	DRV-04 [Motor Speed], FU2-74 [Motor RPM Display Gain]
Function alteration prevention	FU2-94 [Parameter Lock]
Energy Saving	FU1-39 [Energy Saving]
Auto restart operation after alarm stop	FU2-27~28 [Auto Retry]
2 nd motor operation	FU2-81~90 [2 nd Function]
PID feedback operation	FU2-50~54 [PID Operation]
Frequency reference signal and output adjusting	I/O-01~10 [Analog Frequency Setting]
Define the multi function input terminals	I/O-12~14 [Define the Multi Function Input Terminals]
Define the multi function output terminals	I/O-44 [Multi Function Output Setting]
Commercial line <-> inverter switchover operation	I/O-12~14 [Define the Multi Function Input Terminals], I/O-44 [Multi function Output Setting]
Frequency meter calibration	I/O-40~41 [FM Output]
Operate by communicating with a computer	I/O-46 [Inverter No.], I/O-47 [communication Speed], I/O-48~49 [Loss of Reference]

APPENDIX B- PERIPHERAL DEVICES

Inverter Models	Motor [HP]	MCCB, ELB	Magnetic Contactor	Wire, mm ² (AWG)			AC Input Fuse	AC Reactor
				R,S,T	U,V,W	Ground		
SV004ACtionMaster -1	0.5	ABS33a, EBS33	GMC-9P	2 (14)	2 (14)	3.5 (12)	10 A	2.13 mH, 5.7 A
SV008ACtionMaster -1	1	ABS33a, EBS33	GMC-9P	2 (14)	2 (14)	3.5 (12)	10 A	2.13 mH, 5.7 A
SV015ACtionMaster -1	2	ABS33a, EBS33	GMC-9P	2 (14)	2 (14)	3.5 (12)	15 A	1.20 mH, 10 A
SV004ACtionMaster -2	0.5	ABS33a, EBS33	GMC-9P	2 (14)	2 (14)	3.5 (12)	10 A	2.13 mH, 5.7 A
SV008ACtionMaster -2	1	ABS33a, EBS33	GMC-9P	2 (14)	2 (14)	3.5 (12)	10 A	2.13 mH, 5.7 A
SV015ACtionMaster -2	2	ABS33a, EBS33	GMC-9P	2 (14)	2 (14)	3.5 (12)	15 A	1.20 mH, 10 A
SV022ACtionMaster -2	3	ABS33a, EBS33	GMC-9P	2 (14)	2 (14)	3.5 (12)	25 A	0.88 mH, 14 A
SV037ACtionMaster -2	5	ABS33a, EBS33	GMC-18P	3.5 (12)	3.5 (12)	3.5 (12)	40 A	0.56 mH, 20 A
SV040ACtionMaster -2	5.4	ABS33a, EBS33	GMC-18P	3.5 (12)	3.5 (12)	3.5 (12)	40 A	0.56 mH, 20 A
SV004ACtionMaster -4	0.5	ABS33a, EBS33	GMC-9P	2 (14)	2 (14)	2 (14)	6 A	8.63 mH, 2.8 A
SV008ACtionMaster -4	1	ABS33a, EBS33	GMC-9P	2 (14)	2 (14)	2 (14)	6 A	8.63 mH, 2.8 A
SV015ACtionMaster -4	2	ABS33a, EBS33	GMC-9P	2 (14)	2 (14)	2 (14)	10 A	4.81 mH, 4.8 A
SV022ACtionMaster -4	3	ABS33a, EBS33	GMC-9P	2 (14)	2 (14)	2 (14)	15 A	3.23 mH, 7.5 A
SV037ACtionMaster -4	5	ABS33a, EBS33	GMC-12P	2 (14)	2 (14)	2 (14)	20 A	2.34 mH, 10 A
SV040ACtionMaster -4	5.5	ABS33a, EBS33	GMC-12P	2 (14)	2 (14)	2 (14)	20 A	2.34 mH, 10 A

DECLARATION OF CONFORMITY

Council Directive(s) to which conformity is declared:

CD 73/23/EEC and CD 89/336/EEC

Units are certified for compliance with:

**EN50178 (1997)
EN 50081-1 (1992)
EN 55022 (1994)
EN 50082-2 (1995)
EN 61000-4-2 (1995)
ENV 50140 (1993) & ENV 50204 (1995)
EN 61000-4-4 (1995)
EN 61000-4-5 (1995)
ENV 50141 (1993)
EN 61000-4-8 (1993)
EN 61000-4-11 (1994)**

Type of Equipment:

Inverter (Power Conversion Equipment)

Model Name:

ACtionMaster Series

Trade Mark:

Cleveland Motion Controls

Representative:

IMC, International Motion Controls

Address:

**369 Franklin Street
Buffalo, New York , 14202
USA**

Manufacturer:

Cleveland Motion Controls.

Address:

**7550 Hub Parkway
Cleveland, Ohio, 44125
USA**

TECHNICAL STANDARDS APPLIED

The standards applied in order to comply with the essential requirements of the Directives 73/23/CEE "Electrical material intended to be used with certain limits of voltage" and 89/336/CEE "Electromagnetic Compatibility" are the following ones:

-
- **EN 50178 (1997)** "Safety of information technology equipment".
 - **EN 50081-1 (1992)** "Electromagnetic compatibility. Generic emission standard. Part 1: Residential, commercial and light industry."
 - **EN 55022 (1994)** "Limits and methods of measurements of radio interference characteristics of information technology equipment."
 - **EN 50082-1 (1997)** "Electromagnetic compatibility. Generic immunity standard. Part 1: Residential, commercial and light industry."
 - **EN 61000-4-2 (1995)** "Electromagnetic compatibility (EMC). Part 4: Testing and measurement techniques. Section 2: Electrostatic discharge immunity test. Basic EMC Publication (IEC 1000-4-2: 1995)."
 - **ENV 50140 (1993)** "Electromagnetic compatibility - Basic immunity standard - Radiated radio- frequency electro magnetic field - Immunity test."
 - **ENV 50204 (1995)** "Radio electromagnetic field from digital radio telephones."
 - **EN 61000-4-4: 1995** "Electromagnetic compatibility (EMC). Part 4: Testing and measurement techniques. Section 4: Electrical fast transients / burst immunity test. Basic EMC Publication (IEC 1000-4-4: 1995)."
 - **EN 61000-4-5: 1995** "Electromagnetic compatibility (EMC). Part 4: Testing and measurement techniques. Section 5: Surge immunity test. Basic EMC Publication (IEC 1000-4-5: 1995)."
 - **ENV 50141 (1993)** "Electromagnetic compatibility. Basic immunity standard. Conducted disturbances induced by radio-frequency fields."
 - **EN 61000-4-8: 1993** "Electromagnetic compatibility (EMC). Part 4: Testing and measurement techniques. Section 8: Power frequency magnetic field immunity test - Basic EMC Publication (IEC 1000-4-8: 1993)."
 - **EN 61000-4-11: 1994** "Electromagnetic compatibility (EMC). Part 4: Testing and measurement techniques. Section 11: Voltage dips, short interruptions and voltage variations immunity tests (IEC 1000-4-11: 1994)."
-

EMC INSTALLATION GUIDE

CMC inverters are tested to meet Electromagnetic Compatibility (EMC) Directive 89/336/EEC and Low Voltage (LV) Directive 73/23/EEC using a technical construction file. However, Conformity of the inverter with CE EMC requirements does not guarantee an entire machine installation complies with CE EMC requirements. Many factors can influence total machine installation compliance.

Essential Requirements for CE Compliance

Following conditions must be satisfied for CMC inverters to meet the CE EMC requirements.

1. CE compatible CMC inverter
2. Installing inverter in an EMC enclosure
3. Grounding enclosure and shielded parts of wire
4. RFI filter on inverter input side
5. Using shielded cable
6. Ferrite core on inverter output side

RFI FILTERS

THE L.G. RANGE OF POWER LINE FILTERS FF (Footprint) – FE (Standard) SERIES, HAVE BEEN SPECIFICALLY DESIGNED WITH HIGH FREQUENCY CMC INVERTERS, THE USE L.G. FILTERS, WITH THE INSTALLATION ADVICE OVERLEAF HELP TO ENSURE TROUBLE FREE USE ALONG SIDE SENSITIVE DEVICES AND COMPLIANCE TO CONDUCTED EMISSION AND IMMUNITY STANDARDS TO EN50081

CAUTION

IN CASE OF A LEAKAGE CURRENT PROTECTIVE DEVICES IS USED ON POWER SUPPLY, IT MAY BE FAULT AT POWER-ON OR OFF.

IN AVOID THIS CASE, THE SENSE CURRENT OF PROTECTIVE DEVICE SHOULD BE LARGER THAN VALUE OF LAKAGE CURRENT AT WORST CASE IN THE BELOW TABLE.

RECOMMENDED INSTALLATION INSTRUCTIONS

To conform to the **EMC** directive, it is necessary that these instructions be followed as closely as possible. Follow the usual safety procedures when working with electrical equipment. All electrical connections to the filter, inverter and motor must be made by a qualified electrical technician.

- 1-) *Check the filter rating label to ensure that the current, voltage rating and part number are correct.*
- 2-) *For best results the filter should be fitted as closely as possible to the incoming mains supply of the wiring enclosure, usually directly after the enclosures circuit breaker or supply switch.*
- 3-) *The back panel of the wiring cabinet of board should be prepared for the mounting dimensions of the filter. Care should be taken to remove any paint etc. from the mounting holes and face area of the panel to ensure the best possible earthing of the filter.*
- 4-) *Mount the filter securely.*
- 5-) *Connect the mains supply to the filter terminals marked **LINE**, connect any earth cables to the earth stud provided. Connect the filter terminals marked **LOAD** to the mains input of the inverter using short lengths of appropriate gauge cable.*

6-) Connect the motor and fit the ferrite core (output chokes) as close to the inverter as possible. Armoured or screened cable should be used with the 3 phase conductors only threaded twice through the center of the ferrite core. The earth conductor should be securely earthed at both inverter and motor ends. The screen should be connected to the enclosure body via and earthed cable gland.

7-) Connect any control cables as instructed in the inverter instructions manual.

IT IS IMPORTANT THAT ALL LEAD LENGTHS ARE KEPT AS SHORT AS POSSIBLE AND THAT INCOMING MAINS AND OUTGOING MOTOR CABLES ARE KEPT WELL SEPARATED.

FF SERIES (Footprint)

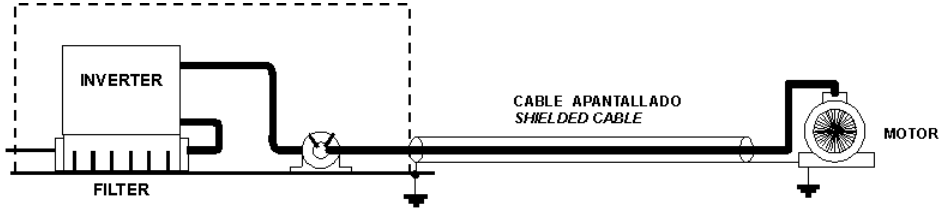

FE SERIES (Standard)

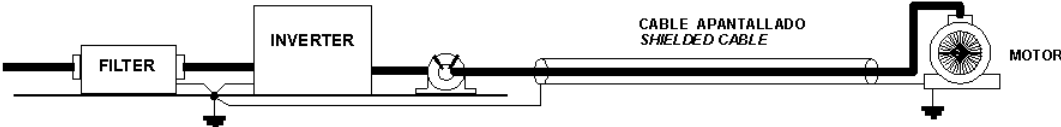

RFI Filters (Footprint - Standard) for ACTIONMASTER SERIES

iG5 series / Filtros Footprint / Footprint Filters											
VARIADOR INVERTER	POT. POWER	CODIGO CODE	INTENS. CURRENT	TENSION VOLTAGE	CORRIENTE DE FUGAS LEAKAGE CURRENT	DIMENSIONES DIMENSIONS L W H	MONTAJE MOUNTING Y X	PESO WEIGHT	TORNILLOS DE FIJACION MOUNT	CHOQUES DE SALIDA OUTPUT CHOKES	
MONOFASICOS SINGLE PHASE (max.)											
SV004iG5-1	0.4kW	FFG5-M010-1	10A	250VAC	3.5mA	173.5 x 103.5 x 40	159.5 x 80		M4	FS - 1	
SV008iG5-1	0.8kW	FFG5-M011-1	11A	250VAC	3.5mA	173.5 x 133.5 x 40	159.5 x 110		M4	FS - 1	
SV015iG5-1	1.5kW	FFG5-M020-1	20A	250VAC	3.5mA	173.5 x 153.5 x 45	159.5 x 130		M4	FS - 2	
TRIFASICOS THREE PHASE NOM. MAX.											
SV004iG5-2	0.4kW	FFG5-T005-1	5A	250VAC	0.3mA	18mA	173.5 x 103.5 x 40	159.5 x 80		M4	FS - 1
SV008iG5-2	0.8kW										
SV015iG5-2	1.5kW	FFG5-T012-1	12A	250VAC	0.3mA	18mA	173.5 x 133.5 x 40	159.5 x 110		M4	FS - 2
SV022iG5-2	2.2kW	FFG5-T020-1	20A	250VAC	0.3mA	18mA	173.5 x 153.5 x 45	159.5 x 130		M4	FS - 2
SV040iG5-2	4.0kW										
SV004iG5-4	0.4kW	FFG5-T006-1	6A	380 VAC	0.5mA	27mA	173.5 x 133.5 x 40	159.5 x 110		M4	FS - 1
SV008iG5-4	0.8kW										
SV015iG5-4	1.5kW										
SV022iG5-4	2.2kW	FFG5-T011-1	11A	380 VAC	0.5mA	27mA	173.5 x 153.5 x 45	159.5 x 130		M4	FS - 2
SV040iG5-4	4.0kW										

iG5 series / Filtros Estándar / Standard Filters											
VARIADOR INVERTER	POT. POWER	CODIGO CODE	INTENS. CURRENT	TENSION VOLTAGE	CORRIENTE DE FUGAS LEAKAGE CURRENT	DIMENSIONES DIMENSIONS L W H	MONTAJE MOUNTING Y X	PESO WEIGHT	TORNILLOS DE FIJACION MOUNT	CHOQUES DE SALIDA OUTPUT CHOKES	
MONOFASICOS SINGLE PHASE (max.)											
SV004iG5-1	0.4kW	FE-M010-(x)	10A	250VAC	3.5mA	150 x 55 x 45	140 x 36		---	FS - 1	
SV008iG5-1	0.8kW										
SV015iG5-1	1.5kW	FE-M015-(x)	15A	250VAC	3.5mA	150 x 55 x 45	140 x 36		---	FS - 2	
TRIFASICOS THREE PHASE NOM. MAX.											
SV004iG5-2	0.4kW	FE-T006-(x)	6A	250VAC	0.3mA	18mA	250 x 110 x 60	238 x 76		---	FS - 2
SV008iG5-2	0.8kW										
SV015iG5-2	1.5kW	FE-T012-(x)	12A	250VAC	0.3mA	18mA	250 x 110 x 60	238 x 76		---	FS - 2
SV022iG5-2	2.2kW	FE-T020-(x)	20A	250VAC	0.3mA	18mA	270 x 140 x 60	258 x 106		---	FS - 2
SV040iG5-2	4.0kW										
SV004iG5-4	0.4kW	FE-T006-(x)	6A	380VAC	0.5mA	27mA	250 x 110 x 60	238 x 76		---	FS - 2
SV008iG5-4	0.8kW										
SV015iG5-4	1.5kW										
SV022iG5-4	2.2kW	FE-T012-(x)	12A	380VAC	0.5mA	27mA	250 x 110 x 60	238 x 76		---	FS - 2
SV040iG5-4	4.0kW										

- (x) (1) Industrial environment EN 50081-0 (A class)
 (2) Domestic and industrial environment EN 50081-1 (B class)

DIMENSIONS

FF SERIES (Footprint)

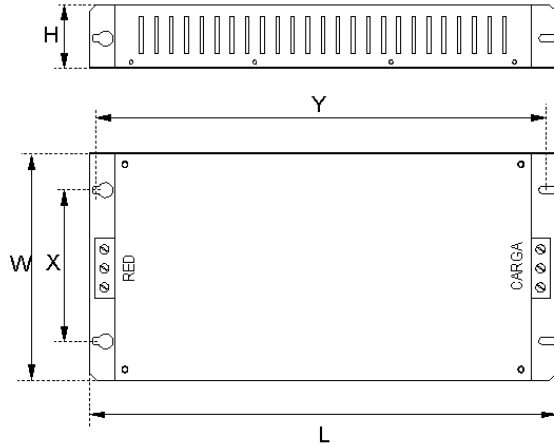

FE SERIES (Standard)

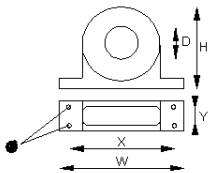
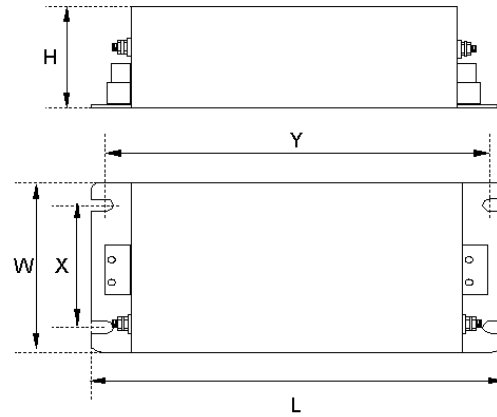

FS SERIES (output chokes)

TIPO	D	W	H	X	O
FS - 1	21	85	46	70	5
FS - 2	28.5	105	62	90	5
FS - 3	48	150	110	125 x 30	5
FS - 4	58	200	170	180 x 45	5

Revision History

No.	Revision	Date	Remarks
1	First Edition New features in V5.30 include: ✧ V1-Ext function added in code I/O-12 (P.30) ✧ Dimensions changed in depth (150.9mm → 152.9mm) ✧ Miss-wiring protective function deleted	March 21, 2002	S/W version: V5.30



Cleveland Motion Controls

CMC constantly endeavors to improve its product so that information in this manual is subject to change without notice.

Visit Our Website: <http://www.cmcccontrols.com/>

03/21/2002

Publication #: 10310000291