

# Owner's Manual

5.35

5.33

5.31

Elliptical Fitness CrossTrainers™



**PRECOR**<sup>®</sup>  
USA  
move beyond<sup>®</sup>



## Important Safety Instructions

When using the EFX, always take basic precautions, including the following:

- Read all instructions before using the EFX. These instructions are written for your safety and to protect the unit.
- Before beginning any fitness program, see your physician for a complete physical examination.

*Il est conseillé de subir un examen médical complet avant d'entreprendre tout programme d'exercice. Si vous avez des étourdissements ou des faiblesses, arrêtez les exercices immédiatement.*

### **DANGER**

**To reduce the risk of electrical shock always unplug the EFX from the electrical outlet immediately after using and before cleaning.**

### **WARNING**

**To reduce the risk of burns, fire, electric shock, or injury, take the following precautions:**

- Do not allow children or those unfamiliar with its operation on or near the EFX. Do not leave children unsupervised around the unit.
- Never leave the EFX unattended when it is plugged in. Unplug the EFX from the power source when it is not in use, before cleaning it, and before providing authorized service.
- Assemble and operate the EFX on a solid, level surface. Locate the EFX a few feet from walls or furniture. Keep the area around the EFX clear.
- Maintain the EFX in good working condition. Refer to the *Maintenance* section. Routinely check and make sure that all fasteners are secure.
- Use the EFX only for its intended purpose as described in this manual. Do not use accessory attachments that are not recommended by the manufacturer, as such attachments may cause injuries.
- Never operate the unit if it is damaged, not working properly, when it has been dropped, or has been immersed in water. Return the EFX to a service center for examination and repair.
- Keep the power cord and plug away from heated surfaces.
- Do not operate the EFX where aerosol (spray) products are being used or where oxygen is being administered.

- Do not use outdoors.
- Do not attempt to service the EFX yourself except to follow the maintenance instructions found in this manual.
- Never drop or insert objects into any opening. Keep hands away from moving parts.
- Keep all electrical components, such as the power cord and power switch, away from liquids to prevent shock.
- Do not hang anything on the handrails, moving handlebars, or covers. Place liquids, magazines, and books in the appropriate receptacles.

**DANGER**    **The EFX must be connected to a properly grounded outlet. See *Grounding Instructions*.**

- Wear proper exercise clothing and shoes for your workout and avoid loose clothing. Do not wear shoes with heels or leather soles. Check the soles of your shoes and remove any dirt and embedded stones. Tie long hair back.
- Use care when getting on or off the EFX. Use the stationary handrail for stability.
- For safety, hold onto a stationary handrail while using the EFX.

- Keep your body and head facing forward. Never attempt to turn around on the EFX.
- Never place your hands or feet in the path of the roller arm because injury may occur to you or damage may occur to the equipment.
- Always use the locking pin to secure the foot pedals when the EFX is not in use.
- Do not rock the unit. Do not stand on the handrail(s), display console, or covers.
- Do not overexert yourself or work to exhaustion. If you feel any pain or abnormal symptoms, stop your workout immediately and consult your physician.
- When the EFX is not in use, disconnect the unit by turning the power switch to the Off position, and then remove the power plug from the wall outlet.

### **Safety Approval**

When identified with the ETL-c logo, the unit has been tested and conforms to the requirements of CAN/CSA-E-335-1/3-04, EN 60335-1: 2002 Safety of Household and Similar Electrical Appliances.

## Grounding Instructions

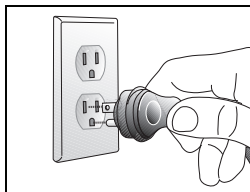
The EFX must be grounded. If the unit malfunctions or breaks down, grounding provides a path of least resistance for electric current, which reduces the risk of electrical shock. The unit is equipped with a power cord having an equipment-grounding conductor and a grounding plug. The plug must be inserted into an outlet that is properly installed and grounded in accordance with all local codes and ordinances. Failure to properly ground the EFX could void the Precor Limited Warranty.

### **DANGER**

Improper connection of the equipment-grounding conductor can result in a risk of electric shock. Check with a qualified electrician or service person if you are in doubt as to whether the unit is properly grounded. Do not modify the plug provided with the EFX. If it does not fit the outlet, get a proper outlet installed by a qualified electrician.

## 120 V Units Designated for U.S. Markets

The grounding plug on the EFX looks like the plug shown in Diagram 1. The power outlet must have the same configuration as the plug. No adapter should be used with this product.



**Diagram 1: 120-volt power plug**

## Radio Frequency Interference (RFI)

### Federal Communications Commission, Part 15

The EFX has been tested and found to comply with the limits for a Class B digital device, pursuant to Part 15 of the FCC Rules. These limits are designed to provide reasonable protection against harmful interference in a residential installation. The EFX generates, uses, and can radiate radio frequency energy and, if not installed and used in accordance with the owner's manual instructions, may cause harmful interference to radio communications.

**WARNING** Per FCC rules, changes or modifications not expressly approved by Precor could void the user's authority to operate the equipment.

## Canadian Department of Communications

This digital apparatus does not exceed the Class B limits for radio noise emissions from digital apparatus set out in the Radio Interference Regulations of the Canadian Department of Communications.

*Le présent appareil numérique n'émet pas de bruits radioélectriques dépassant les limites applicables aux appareils numériques de la class B prescrites dans le Règlement sur le brouillage radioélectrique édicté par le ministère des Communications du Canada.*

### ATTENTION: Haute Tension

**Débranchez avant de réparer**

## European Applications

This product conforms to the requirements of the European Council Directive 2004/108/EC, Electromagnetic Compatibility and has been tested to the following standards:

- EN55022, Limits & Methods of Measurement of Radio Interference, Information Technology Equipment.
- EN50024, Immunity of Information Technology Equipment

This product is compliant to 2002/95/EC, Restriction of Hazardous Substances Directive.

This product also conforms to the requirements of the European Council Directive 2006/95/EC, Low Voltage Directive and has been tested to the following standard:

- IEC 335-1, Safety of Household and similar Electrical Appliances.

## Obtaining Service

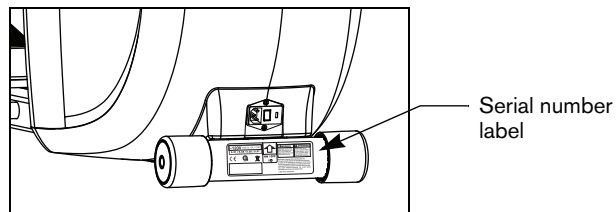
You should not attempt to service the EFX except for maintenance tasks as described in this manual. The EFX does not contain any user-serviceable parts that require lubrication. For information about product operation or service, see the Precor web site at [www.precor.com](http://www.precor.com).

Should you need more information regarding customer support numbers or a list of Precor authorized service centers, visit the Precor web site at [www.precor.com/corp/](http://www.precor.com/corp/) contact.

For future reference, write the model, serial number, and date of purchase for your unit in the space provided. The serial number is printed on a label located beneath the power receptacle (Diagram 2).

Model #: \_\_\_\_\_ Serial #: \_\_\_\_\_

Date purchased: \_\_\_\_\_



**Diagram 2: Location of serial number**

# Table of Contents

## **Important Safety Instructions ..... 1**

Safety Approval .....	2
Grounding Instructions .....	3
Radio Frequency Interference (RFI) .....	4
European Applications .....	5
Obtaining Service .....	5

## **EFX Features .....9**

The Locking Pin .....	9
Converting Handlebar Positions .....	10
Using the Stationary Handrail .....	11
Moving Handlebars Support the Total Body Workout .....	11
Turning the Unit On and Off .....	11
Weight Limit .....	11
Location .....	12

## **Heart Rate Features ..... 13**

Important Use and Safety Information .....	13
Using the Heart Rate .....	
Touch-Sensitive Handrail Grips .....	16
Using SmartRate .....	16
Exercise to Your Target Heart Rate .....	18
Heart Rate Analysis .....	18

## **Display Console .....19**

More Information about the Upper Display .....	20
More Information about the Lower Display .....	21
Keypads .....	23

## **User Identification .....28**

Adding a User .....	29
Updating User Information on the EFX5.35 .....	30
Updating User Information on the EFX5.31 or EFX5.33 .....	31
Changing the User Name and Clearing Workout Statistics .....	32

## **Workout Options .....33**

Choosing QUICKSTART .....	34
Selecting a Program .....	35
Selecting a User Key .....	36
Cooling Down After a Workout .....	37
Pausing During a Workout or the Cool-Down Period .....	38
Ending a Workout .....	38



**Programs ..... 39**

Choosing a Program ..... 39  
Changing Programs in Mid-session ..... 39  
Program Tips ..... 40  
Manual Program ..... 41  
Interval Program ..... 41  
Aerobic Endurance Program ..... 42  
Hill Climb Program ..... 42  
Heart Rate Programs ..... 43  
Fitness Test Program ..... 44  
Weight Loss Programs ..... 46  
Gluteal Program ..... 47  
CrossTrainer Program ..... 47

**Advanced Programming and Troubleshooting ..... 48**

Advanced Programming Tips ..... 48  
Changing EFX Settings ..... 49  
Informational Displays ..... 51  
Troubleshooting Error Codes ..... 54  
Troubleshooting Heart Rate ..... 55

**Maintenance .....56**

Inspection ..... 56  
Cleaning the Equipment ..... 56  
Storing the Chest Strap ..... 57  
Long-Term Storage ..... 57

**Precor Residential Equipment  
Limited Warranty..... 58**

*Notes:*

# EFX Features

The EFX is equipped with certain items that, when used properly, help sustain a safe and enjoyable workout. These items include:

- Locking pin location
- Convertible handlebars (EFX5.35. only)
- Stationary handrails with heart rate feature (EFX5.35 and EFX 5.33 only)
- Moving handlebars (EFX5.35 and EFX5.33 only)
- Power switch location

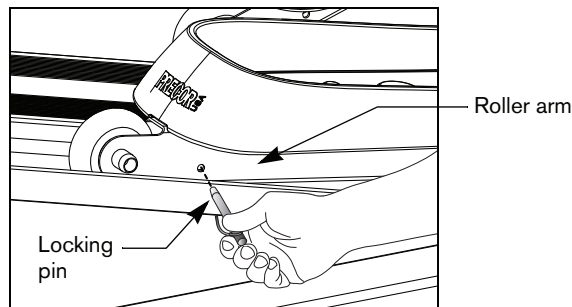
## The Locking Pin

**CAUTION: Always use the locking pin to secure the foot pedals when the EFX is not in use.**

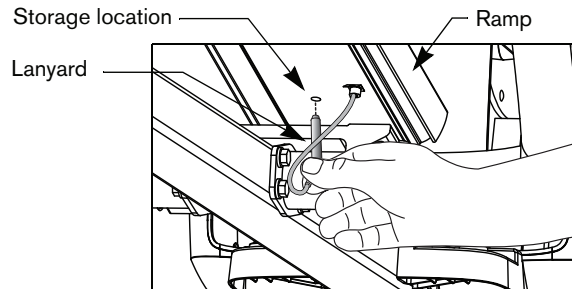
The locking pin secures the foot pedals to keep them from traveling up or down the ramp. Before beginning your workout, pull firmly on the pin to slide it out of the roller arm. Refer to Diagram 3. A lanyard attaches the locking pin to the ramp.

Store the locking pin underneath the ramp once it is removed from the roller arm. Refer to Diagram 4.

After exercising, use the locking pin to secure the foot pedals.



**Diagram 3: Remove locking pin before exercising**

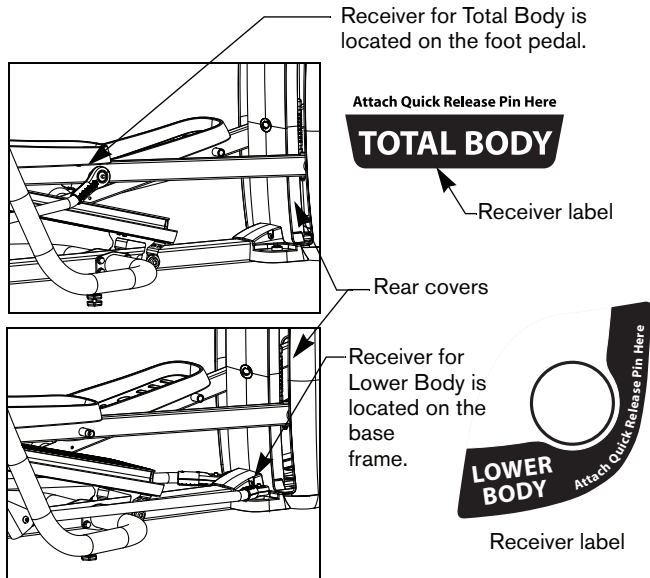


**Diagram 4: Store the locking pin under the ramp**

## Converting Handlebar Positions

The EFX5.35 handlebars can be locked in either a stationary (Lower Body) or moving arm (Total Body) position depending on your exercise preference. Refer to Diagram 5.

**CAUTION: Never attempt to change the handlebar connection when the EFX5.35 is in use.**



**Diagram 5: Converting the handlebars**

The following steps explain how to convert the handlebars from a Lower Body to a Total Body position or vice versa.

1. Hold the link arm securely with one hand as you press the button on the quick release pin with your thumb. Pull the quick release pin out of its receiver.
2. Rotate the link arm 90° so the quick release pin is aligned with the other receiver. For example, the locking receiver for the Total Body handlebars is beneath the foot pedal. If you wish to lock the handlebars in the Lower Body position, the locking receiver is on the base frame just in front of the rear cover.

**CAUTION: Be aware of handlebar movement. If you move the link arm, it also causes the handlebar to move. Do not drop the link arm. Dropping the link arm may chip the paint on the EFX. To avoid injury to you or your assistants, be aware of the location of the handlebars during the conversion process.**

3. Press the button on the quick release pin and slide the pin into the appropriate receiver.
4. Let go of the button and make sure the link arm is securely locked into position by pushing and pulling it firmly.
5. Perform the same steps for the opposite handlebar.

**CAUTION: Make sure the quick release pin is fully engaged in the receiver and locked in position before using the EFX.**

## Using the Stationary Handrail

To maintain your balance, always grasp a stationary handrail when you step on or off the foot pedals, and when you use the keypad.

To learn more about the touch-sensitive handrail grips on the EFX5.35 and EFX5.33, refer to *Heart Rate Features*.

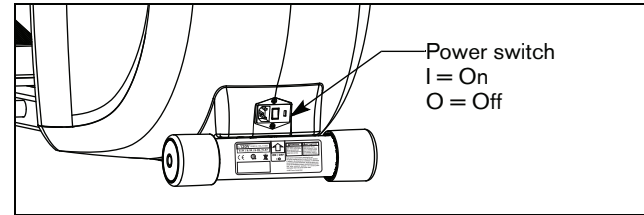
## Moving Handlebars Support the Total Body Workout

The handlebars on the EFX5.35 and EFX5.33 provide an upper-body workout which helps increase cardiovascular fitness. By adding the total body movement to your cross training workout, you are actually increasing your work effort and enhancing your overall fitness level.

## Turning the Unit On and Off

To turn the unit On and Off, use the power switch located at the rear of the unit, near the power cord receptacle. Refer to Diagram 6.

**Important:** *When it is not being used, turn the unit Off.*



**Diagram 6: Power switch**

## Weight Limit

The equipment has been durability tested to 350 lb (160 kg).

## Location

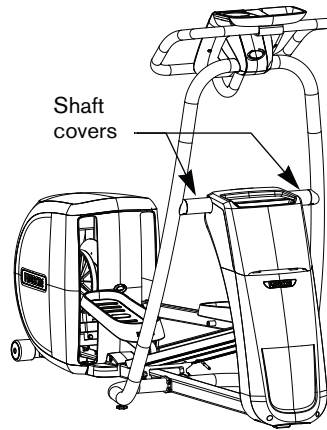
It is important to keep a minimum of one foot (30 cm) around the EFX open and free from encumbrances such as other equipment.

**CAUTION: If you plan to move the EFX, obtain help and use proper lifting techniques.**

To move the EFX, the two of you need to stand on opposite sides and face the rear of the EFX. Follow the appropriate steps for the EFX you own.

### EFX5.31

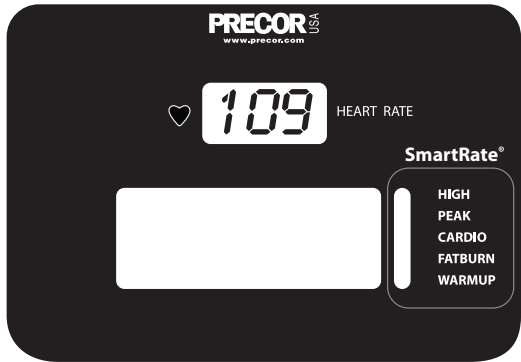
1. Have your assistant grasp one shaft cover while you grasp the opposite one.
2. Lift the EFX and roll it on the rear rollers to the desired location.



### EFX5.33 and EFX5.35

1. Lock the handlebars in the Lower Body position. Refer to the labels on the base of the EFX and to the instructions found in *Converting Handlebar Positions*.
2. Determine a comfortable height for lifting and have your assistant grasp one handlebar while you grasp the opposite one.
3. Lift the EFX and roll it on the rear rollers to the desired location.

# Heart Rate Features



Heart rate and SmartRate<sup>®</sup> features are available when you wear the chest strap or grasp both touch-sensitive handrail grips.

**Note:** The EFX5.31 does not have touch-sensitive handrail grips. To use the heart rate and SmartRate features, a chest strap must be worn. To purchase a chest strap, contact your dealer. Refer to *Obtaining Service*.

When a heartbeat is detected, the HEART RATE display shows your heart rate and, if your age has been entered, the SmartRate LED pulses and indicates your target zone.

## Important Use and Safety Information

Read the following before using the heart rate or SmartRate features.

- Consult your physician before engaging in any vigorous exercise. Do not use the heart rate programs until authorized by your physician.
- Know your heart rate and your physician-recommended heart rate target zone. Individual heart rates vary according to several physiological factors and may not correspond directly with Diagram 7.

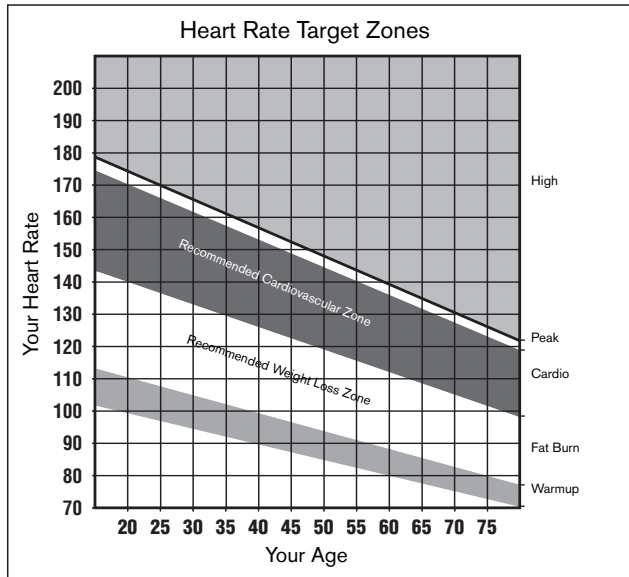
- The calculation used for the heart rate target zone is:  $(220 \text{ minus your age}) \text{ multiplied by a percent.}$

For example:

Low range:  $(220 \text{ minus your age}) \text{ multiplied by } 55\%$

High range:  $(220 \text{ minus your age}) \text{ multiplied by } 85\%$

Refer to Table 1 in *Using SmartRate*.



**Diagram 7: Heart rate target zones**

- After you put on the chest strap, face the display console for a few seconds. This allows the receiver in the console to recognize the signal from the chest strap.
- If **Hr** appears in the display, the EFX is detecting a signal, but has not yet determined your heart rate. Make sure the chest strap is positioned properly around your chest and against your skin.
- If you prefer to use the touch-sensitive handrail grips on the EFX5.35 or EFX5.33, grasp both grips and wait five to ten seconds. Make sure both hands are moist.

**Note:** When a signal is detected, the heart rate icon flashes and a number appears in the HEART RATE display and indicates your heart rate.

- Always face forward on the EFX and use the stationary handrail for balance. Keep upper body movement to a minimum.

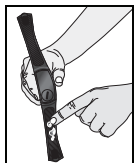


## Wearing a Chest Strap

During a workout, the heart rate features appear on the display when you wear a chest strap. To receive an accurate reading, the chest strap needs to be in direct contact with your skin.

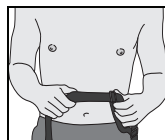
1. Carefully dampen the back of the strap with tap water. Refer to Diagram 8.

**Note:** Do not use deionized water. It does not have the proper minerals and salts to conduct electrical impulses.



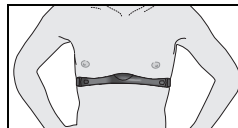
**Diagram 8: Moisten chest strap**

2. Adjust the strap and fasten it around your chest. The strap should feel snug, not restrictive. Refer to Diagram 9.



**Diagram 9: Adjust chest strap**

3. Make sure that the chest strap is right side up, lies horizontally across your chest, and is centered in the middle of your chest. Refer to Diagram 10.



**Diagram 10: Fasten chest strap**

After you put on the chest strap, face the display console for a few seconds. This allows the receiver in the console to recognize the signal from the chest strap.

## Using the Heart Rate Touch-Sensitive Handrail Grips

While exercising on the EFX5.35 or EFX5.33, you must grasp both touch-sensitive handrail grips for a minimum of five to ten seconds to transmit your heart rate to the display. Refer to Diagram 11.

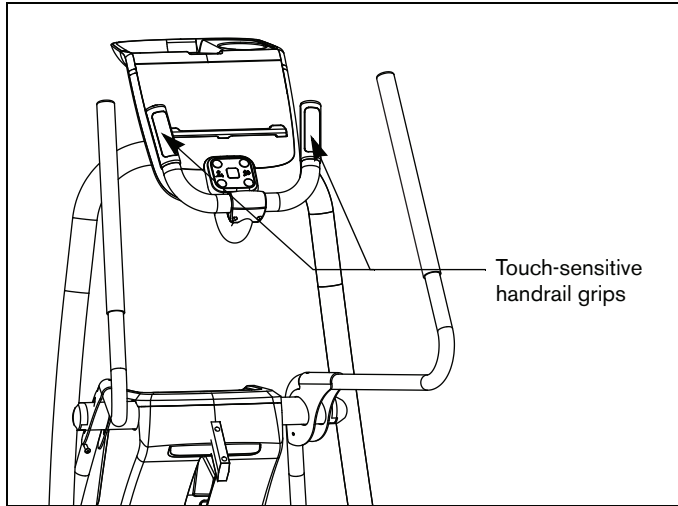


Diagram 11: Touch-sensitive handrail grips

Usually, the concentration of salts in a person's perspiration provides enough conductivity to transmit a signal to the receiver inside the display console. However, some people, because of body chemistry or erratic heart beats cannot use the touch-sensitive heart rate feature on the EFX. A chest strap may provide better results.

**Important:** While exercising, do not grasp the touch-sensitive handrail grips and wear the chest strap at the same time. The touch-sensitive handrail grips override the signals from the chest strap transmitter. If used together, inconsistent readings may occur.

## Using SmartRate

The SmartRate feature helps you monitor and maintain your heart rate in the target zone best suited to your specific needs. All 7 LEDs may light during a workout. When the EFX detects a heart rate, a single LED blinks and indicates the zone that your heart rate is in.

**Important:** To use the SmartRate feature, you must choose a program and enter your age during the setup phase of your exercise session.

Table 1 shows the percents used in calculating the heart rate target zones. While your heart rate remains within these zones, the corresponding light blinks and provide a visual cue.

The calculation used to determine your maximum aerobic heart rate is (220 minus your age). When you multiply it by the percent indicated in Table 1, you can understand the relationship between the pulsating LED and your target heart rate.

**CAUTION: Your heart rate should never exceed 85% of your maximum aerobic heart rate or go above PEAK. If it does, immediately reduce your strides per minute, adjust the CrossRamp, or resistance to return your heart rate to your physician-recommended target zone.**

**Table 1. Heart rate target zones and SmartRate LEDs**

<i>Heart Rate Zone Percent</i>	<i>LED Blinking</i>	<i>Label</i>
Above 87	Seventh	HIGH
85 to 87	Sixth	PEAK
78 to 84	Fifth	CARDIO
70 to 77	Fourth	CARDIO
62 to 69	Third	FATBURN
55 to 61	Second	FATBURN
Below 55	First	WARMUP

The SmartRate indicator lights do not appear when:

- You press QUICKSTART at the banner.
- You do not enter your age before starting a program.
- You do not wear or improperly position the chest strap.
- You fail to grasp both touch-sensitive handrail grips on the EFX5.35 or EFX5.33, for five to ten seconds.

## Exercise to Your Target Heart Rate

A dedicated window displays your heart rate while exercising. To view your heart rate (beats per minute) on the display, either wear a chest strap or grasp both touch-sensitive handrail grips.

**Note:** The EFX5.31 does not have the touch-sensitive handrail grips so you must purchase the optional chest strap transmitter to monitor your heart rate.

The Precor web site ([www.precor.com](http://www.precor.com)) has several suggestions for workouts with varying levels of intensity. It provides many workout details that include the appropriate target heart rate.

The EFX includes a program that lets you exercise based on a specified target heart rate. As you exercise, the Basic HRC Program monitors your heart rate and automatically maintains it within a few beats per minute (bpm) of your selected target.

To use this program, press the PROGRAMS - HEART RATE key. For more information, refer to *Programs*.

## Heart Rate Analysis

Every time you complete a program using the chest strap or touch-sensitive handrail grips, the EFX provides a heart rate analysis after the workout summary.

Your average heart rate appears followed by the maximum heart rate achieved during your workout. A third display appears, if you entered your age, and indicates the amount of time your heart rate remained between the target zones shown.

The heart rate analysis is based on how often your heart rate signal is received while exercising. If you use the chest strap, the average heart rate will be more accurate than if you occasionally grasp the touch-sensitive handrail grips.

# Display Console

**Upper display:** Initially shows the Precor banner. It changes to the program profile when you select a program or press QUICKSTART. A blinking column in the profile indicates your position.

**PROGRAMS keypad:** To begin an exercise session, press a PROGRAMS key to view a menu of programs within each category. For program descriptions, refer to Programs.

**User 1–2:** Press a USER key at the Precor banner to personalize your exercise experience. The information is stored for future exercise sessions.

**Selection key:** Press the key to move through the information in the column, so you can choose what you want to display during your session. Indicator lights appear next to the item that is displayed. You can perform the same function with the right selection key.

**CROSSRAMP arrow keys:** Use the arrow keys to adjust the ramp incline.

**HEART RATE display:** Use a chest strap or grasp both touch-sensitive grips (EFX5.35 or EFX5.33) to display and monitor your pulse.

**SmartRate display:** LEDs light in this column when the SmartRate feature is activated. Follow the LEDs to monitor your heart rate and maintain it in your target zone.

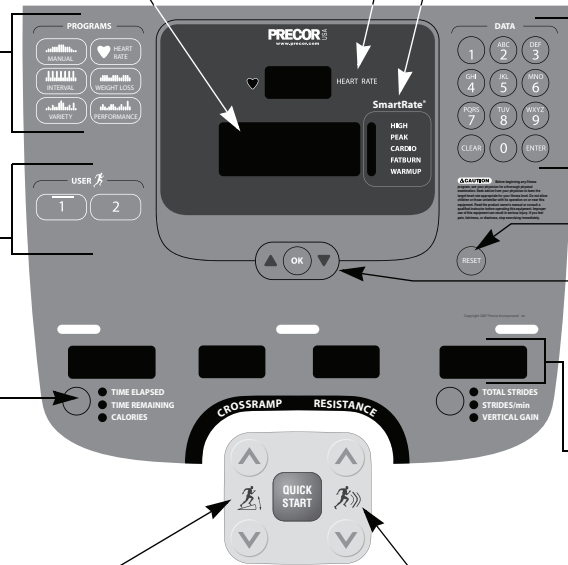
**Number keys:** During an exercise session, use the number keys to answer prompts and update information.

**RESET key:** Press this key to end your session and view your workout summary. Pressing the key a second time, causes the display to reset to the Precor banner.

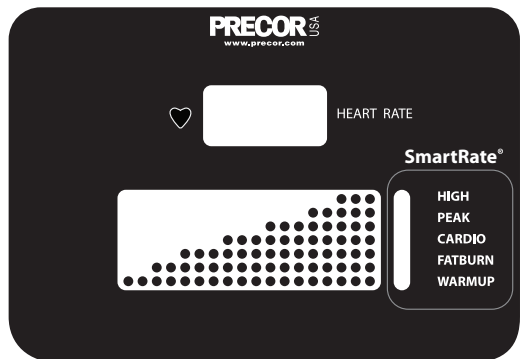
**OK and Navigational arrow keys:** Use the OK key to confirm responses to specific prompts. The up and down arrow keys present the available selections and affect what appears on the display. Refer to the Navigational Keypad.

**Lower display:** While you exercise, six sets of numbers show information about your session. Refer to More Information about the Lower Display

**RESISTANCE arrow keys:** Use the arrow keys to adjust the resistance.



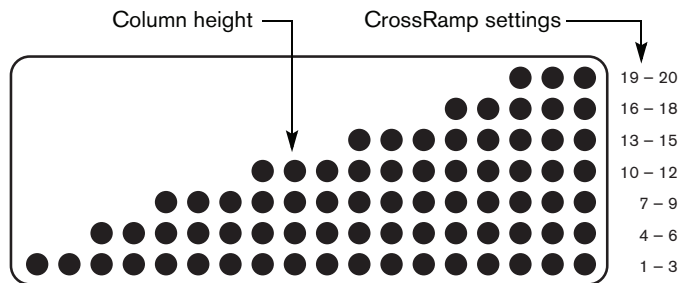
## More Information about the Upper Display



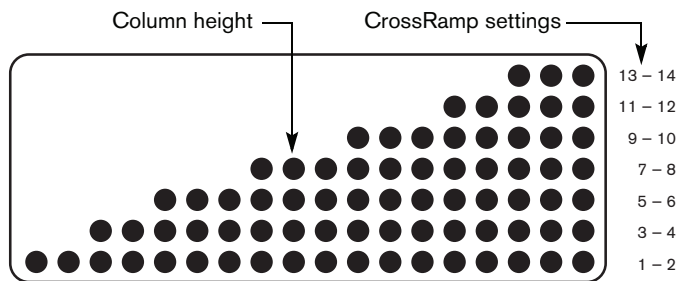
**HEART RATE**—displays your heart rate when you wear a chest strap or grasp both touch-sensitive grips. Refer to *Heart Rate Features*.

**SmartRate**—displays your heart rate as a blinking bar which indicates the zone you are in when you wear a chest strap or grasp both touch-sensitive grips. Refer to *Using SmartRate*.

**PROGRAM PROFILE**—In most programs, the CrossRamp setting affects the column height in the program profile as shown in Diagrams 12 and 13. The profile raises or lowers according to which arrow key is pressed.

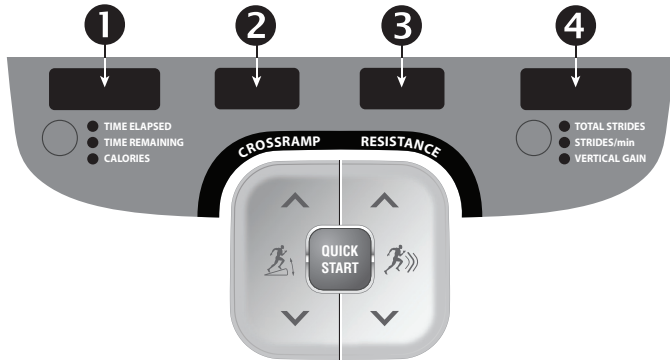


**Diagram 12: EFX5.35 column height in the program profile**



**Diagram 13: EFX5.33 and EFX5.31 column height in the program profile**

## More Information about the Lower Display



The lower display provides information about your exercise session. The two center windows automatically provide information about your CrossRamp and resistance settings. To choose the type of information displayed in the left and right windows, press the adjacent Selection key. The numbers that appear relate to your workout statistics and are described below.

**Note:** If you choose to rest a book or magazine on the display, you can still view these workout statistics.

## 1 TIME ELAPSED, TIME REMAINING and CALORIES

**TIME ELAPSED**—displays workout time in minutes and seconds and indicates the amount of time you have been exercising. When you exceed 60 minutes during a single workout, the TIME ELAPSED display converts to hours and minutes.

**TIME REMAINING**—shows the amount of time remaining in a workout. If the selected workout time is less than 60 minutes, the display shows time in minutes and seconds. If you select a workout time greater than 60 minutes, the display reflects hours and minutes until the countdown reaches 60 minutes, at which time the display reverts to minutes and seconds.

**CALORIES**—displays the estimated cumulative number of calories burned. The calorie calculation is derived from the pedaling speed, resistance, and your weight. An accurate weight entry results in a more accurate calorie count. When using QUICKSTART and a weight has not been specified, the default weight is 150 pounds (68 kilograms).

## 2 **CROSSRAMP**

**CROSSRAMP**—displays the incremental motion affected by the ramp position. The **CROSSRAMP** arrow keys affect the lift and let you set a ramp incline between 1 and 20 on the EFX5.35 and between 1 and 14 on the EFX5.33 and EFX5.31. The value displayed can change in whole number increments.

## 3 **RESISTANCE**

**RESISTANCE**—displays the resistance you feel against your stride. The **RESISTANCE** arrow keys let you set a resistance level between 1 and 20.

## 4 **TOTAL STRIDES, STRIDES/min and VERTICAL GAIN**

**TOTAL STRIDES**—shows the total number of strides completed, which is always an even number since two strides create one complete revolution of the flywheel. A stride is an exaggerated walking movement. On the EFX, if you start in a position with one foot pedal forward, a stride is completed when you move the rear foot pedal all the way forward while the other foot pedal moves to the rear.

**STRIDES/min**—displays the number of strides you complete in a minute up to a maximum value of 510 strides per minute. A stride is an exaggerated walking movement. If you start in a position with one foot plate forward, a stride is completed when you move the rear foot pedal all the way forward while the other foot plate moves to the rear. Two strides create one complete revolution of the flywheel. So, the value that appears on the display is always an even number between 20 and 510. The average, effective exercise pace is between 100 to 150 strides per minute.

**VERTICAL GAIN**—displays an estimate of your cumulative vertical gain in feet or meters based on your CrossRamp level, resistance level, weight, and caloric expenditure. You can use the **VERTICAL GAIN** display as a unique motivational unit of measurement and realize your fitness goals by varying the elliptical motion of the EFX. Higher CrossRamp and resistance levels will result in greater vertical gain.



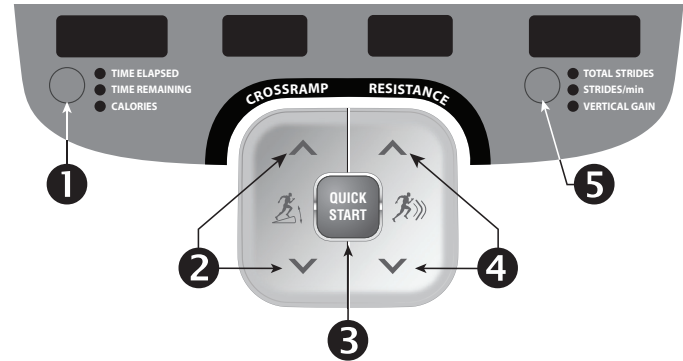
## Keypads

Use the keypads to enter your workout session selections, to affect what appears on the display, and to establish your CrossRamp and resistance preferences.

Five distinct keypads exist on the display and are discussed in this section:

- Lower Display keypad and the Selection keys
- User identification keys
- Navigational keypad in the center of the display
- PROGRAMS keypad
- Number keypad with the ENTER and CLEAR keys

## Lower Display Keypad and the Selection Keys



**Diagram 14: Lower Display keypad and the Selection keys**

- 1 Left Selection Key:** Every time you press this key the display reflects: the time elapsed since you began your exercise session, the time remaining, or your cumulative calories. An LED lights and indicates which information is being displayed. The TIME REMAINING display is lit when you begin a program.

**2 CROSSRAMP:** Press and hold the CROSSRAMP arrow keys to increase or decrease the ramp incline from 1 to 20 on the EFX5.35 or 1 to 14 on the EFX5.33 and EFX5.31.

Changes to the ramp incline are not immediate. It takes time for the lift to reach the target incline shown on the display.

Ramp changes occur only when the foot pedals are in motion. The number that appears on the display indicates the selected CrossRamp setting, not the degree of incline. There is not a one-to-one relationship between the degree of incline and the CrossRamp setting.

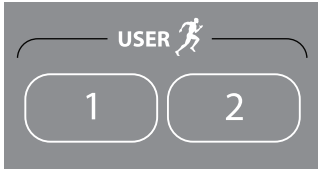
The CrossRamp setting affects the column height in the program profile. Refer to Diagram 12.

**3 QUICKSTART:** Press QUICKSTART to start your workout immediately using the Manual Program. Refer to *Choosing QUICKSTART*.

**4 RESISTANCE:** Press and hold the RESISTANCE arrow keys to increase or decrease the resistance in from 1 to 20.

**5 Right Selection Key:** Every time you press this key the display reflects your cumulative strides, your strides per minute, or your vertical gain. An LED lights and indicates which information is being displayed.

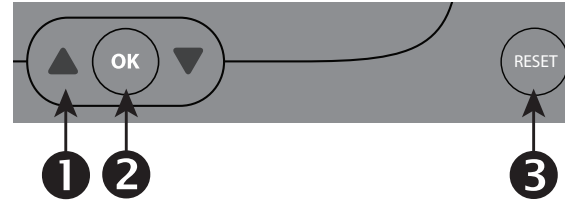
## User Keys



**Diagram 15: User keys**

**USER Keys:** To personalize your exercise session, press a USER key (1 or 2) at the Precor banner. On the EFX5.35, selecting a USER key lets you track your workout statistics from session to session. On the EFX5.35, EFX5.33, and EFX5.31, when you choose a USER key, personal information such as age, weight, and gender are reinstated after you select your preferred program. If you haven't already done so, you'll need to select a user number and enter a user name. For more information, refer to *Adding a User* or *Selecting a User Key*.

## Navigational Keypad

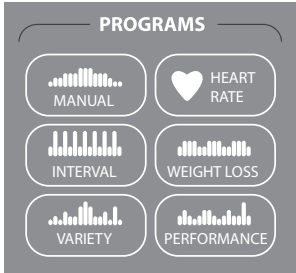


**Diagram 16: Navigational keypad**

The navigational keypad provides several ways to change your exercise session and to display various workout statistics. The OK key, which allows you to confirm display selections, is also part of the navigational keypad.

- 1 Up and Down Arrows:** These up and down arrows present the available selections and affect what appears on the display.
- 2 OK:** Use the OK key to confirm responses to specific prompts.
- 3 RESET:** During an exercise session, press RESET once to end your session and display a workout summary. Press it again to return to the Precor banner. Refer to *Pausing During a Workout or the Cool-Down Period*.

## PROGRAMS Keypad



**Diagram 17: PROGRAMS keypad**

The PROGRAMS keypad provides access to all the exercise programs. Choose one of the six keys by pressing in the center of the key and the top level program in the menu appears on the display. Pressing the key again displays the next program in the menu, if one is available. Refer to Table 2. For a description of each program, refer to *Programs*.

**Note:** Use the OK key to confirm your selection. For more information, refer to *Workout Options*.

**Table 2. Available programs**

<i>PROGRAMS</i> key	<i>Menu Selections</i>
<b>MANUAL</b>	Manual
<b>INTERVAL</b>	Interval
<b>VARIETY</b>	Aerobic Endurance
	Hill Climb
<b>HEART RATE</b>	Basic HRC*
	Fitness Test*
<b>WEIGHT LOSS</b>	Fat Burner
	Weight Loss
<b>PERFORMANCE</b>	Gluteal
	CrossTrainer

\* Use of chest strap or the touch-sensitive handrail grips is required.

## Number Keypad



### Diagram 18: Number keypad

The CLEAR and ENTER keys provide the following functions:

**CLEAR:** Use the CLEAR key to remove the last number being displayed.

**ENTER:** Use the ENTER key to accept the number being displayed.

**Note:** The OK and ENTER keys are interchangeable and provide the same function when no peripheral devices are attached to the EFX.

# User Identification

Choosing a user identification (USER) key enables the EFX to identify you. Once you configure your USER key, you can personalize your workout session and store information about your preferred program, workout time, weight, age, and gender.

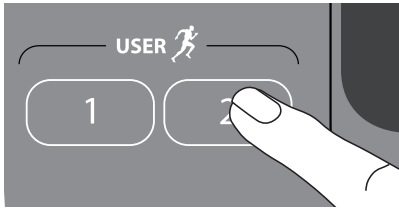
The USER keys allow two people to customize, store, and retrieve workout selections. On the EFX5.35 you can also track your cumulative workout statistics.

Initially, you must “add a user” so the EFX can store exercise session information associated with the specific user key. Once you enter the requested information, it is stored until you opt to change it. You can select the same USER key time and time again, and your user preferences will automatically be re-instated. Refer to *Adding a User*.

This section explains how to:

- Add a user.
- Update your personal information.
- Change the user name and clear your workout statistics.

## Adding a User



To add a user, select a user number by taking the following steps:

1. At the Precor banner, press a USER key. A blinking line prompts you to enter the first letter in your name.
2. Use the alphabet, on the number keypad, to enter your name. To enter a letter, press the appropriate number key repeatedly until the desired letter appears. To erase a letter, press the CLEAR key.
3. Wait until the next cell blinks and continue the process until your name or identification is complete.

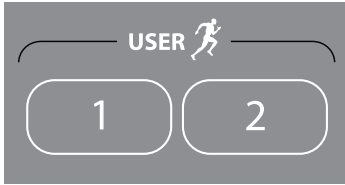
**Note:** Blank spaces between letters are not allowed.

4. When you are satisfied with your name or user identification, press OK.
5. The display then prompts you to enter your weight, age, and gender.

Use the navigational arrow keys or number keys to answer each prompt, and then press OK. With each successful entry, you move onto the next prompt. After you enter the gender type, the display indicates that the user setup is complete and resets to the Precor banner.

To begin an exercise session using your USER key, refer to *Selecting a User Key*.

## Updating User Information on the EFX5.35



To update user information on the EFX5.35 such as weight and age without clearing the workout statistics associated with a USER key, take the following steps:

1. At the Precor banner, press and hold the USER key. A welcome greeting scrolls across the display.

Continue holding the USER key until CHANGE USER [user number]? USER [x] SETUP scrolls across the display. Release the USER key, and then press OK.

2. When your user name appears, do not change it. Accept it as is by pressing OK.

**Important:** If you change your user name, you also delete all cumulative workout statistics associated with the user name.

3. Answer the prompts for weight, age, and gender.

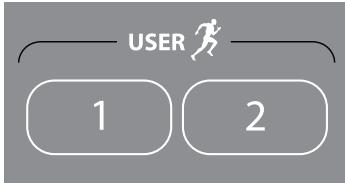
Use the navigational arrow keys or number keys to answer each prompt, and then press OK. With each successful entry, you move onto the next prompt.

4. At the CLEAR [user name] STATISTICS? prompt, choose one of the following options:

1 = No	Pressing number 1 updates user information only. The program preferences and cumulative workout statistics remain intact.
2 = Yes	Pressing number 2 updates user information, but deletes program preferences and cumulative workout statistics. Refer to <i>Updating User Information on the EFX5.31 or EFX5.33</i> .



## Updating User Information on the EFX5.31 or EFX5.33

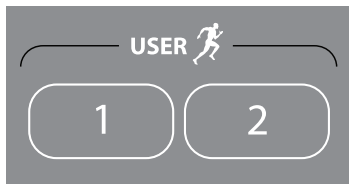


To update user information on the EFX5.33 or EFX5.31, such as weight and age associated with a USER key, take the following steps:

1. At the Precor banner, press and hold the USER key. A welcome greeting scrolls across the display.  
  
Continue holding the USER key until CHANGE USER [user number]? USER [x] SETUP scrolls across the display. Release the USER key, and then press OK.
2. When your user name appears, do not change it. Accept it as is by pressing OK.

3. Answer the prompts for weight and age.  
  
Use the navigational arrow keys or number keys to answer each prompt, and then press OK. With each successful entry, you move onto the next prompt.
4. Use the arrow keys to answer the gender prompt. When you make your selection, the display resets to the Precor banner.

## Changing the User Name and Clearing Workout Statistics



You can clear the stored workout statistics for any USER key by changing the name associated with a USER key.

Changing the user name resets any stored preferences, such as weight and age, to the original factory defaults. On the EFX5.35, the cumulative statistics are reset to zero and the metrics displayed are reset to factory defaults.

1. At the Precor banner, press and hold the USER key while the welcome greeting scrolls across the display.

Continue holding the USER key until CHANGE USER [*user number*]? scrolls across the display. Release the USER key, and then press OK.

2. When your user name appears, a blinking line prompts you to change the first letter.

3. Use the alphabet, on the number keypad, to enter a new name. To enter a letter, press the appropriate number key repeatedly until the desired letter appears. To erase a letter, press the CLEAR key.
4. A blinking space or letter indicates it is ready to receive a new letter. Wait until the next cell blinks and continue the process until your name or user identification is complete.  
**Note:** Blank spaces between letters are not allowed.
5. When you are satisfied with your name or user identification, press OK.
6. The display then prompts you to enter your weight, age, and gender.

Use the navigational arrow keys or number keys to answer each prompt, and then press OK. With each successful entry, you move onto the next prompt. After you enter the gender type, the display indicates that the user setup is complete and resets to the Precor banner.

**Note:** Preferences and workout statistics are cleared and all programs are restored to original default settings.

# Workout Options

**CAUTION:** Before beginning any fitness program, see your physician for a complete physical examination. Know your physician-recommended heart rate target zone.

**Note:** On the EFX5.35, determine whether you want Total Body or Lower Body handlebars and lock the link arms to the appropriate position. Refer to *Converting Handlebar Positions*.

1. Turn the unit On. The Precor banner scrolls across the display.
2. Hold on to a stationary handrail while stepping on the foot pedals.
3. Face the display. When you are comfortably situated, begin pedaling.

**Important:** Before exercising, review the Important Safety Instructions found at the beginning of this manual.

4. Select one of the following options:

<b>Option...</b>	<b>Steps...</b>
To start exercising immediately	Use the QUICKSTART key. Refer to <i>Choosing QUICKSTART</i> .
To view a list of programs	Press a PROGRAMS key. Refer to <i>Selecting a Program</i> .
To begin exercising using personal preferences	Press your USER key. Refer to <i>Selecting a User Key</i> .

## Choosing QUICKSTART



1. While the Precor banner scrolls, start pedaling and press QUICKSTART to begin the Manual Program.

QUICKSTART applies the following defaults:

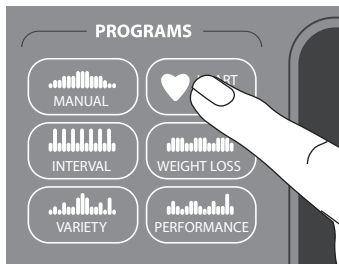
<b>Prompts</b>	<b>Default Value</b>
Program	Manual
Time	30 minutes
Weight	150 lb (68 kg)
Age	0

2. Use the CROSSRAMP and RESISTANCE arrow keys to change the ramp incline and resistance.
3. Find a comfortable stride rate between 100 and 150 strides per minute.

To use the SmartRate feature, you need to specify your age. In this case, review the steps found in *Adding a User* or *Selecting a Program*.

**Note:** When you use the QUICKSTART key, you enter the MANUAL program as a guest user. Workout statistics and your preferences for weight, age, and gender are not stored in memory. To save this type of information, refer to *Selecting a User Key*.

## Selecting a Program



1. While the Precor banner scrolls, repeatedly press one of the PROGRAMS menu keys to review its list of programs. Choose the program you want, and then press OK. For a description of each program, refer to *Programs* or review Table 2 with the *PROGRAMS Keypad*.

**Note:** After pressing a program menu key, you can also scroll through the list of programs within that menu by pressing the navigational arrow keys.

2. A workout time blinks in the center display if you choose a time-based program. Enter a number between 1–240 minutes or zero (NO LIMIT) by using the navigational arrow keys or the number keys, and then press OK.

**Note:** The NO LIMIT option lets you work out indefinitely. Since there is no time limit, an automatic cool-down period is not appended to your program. Refer to *Cooling Down After a Workout*.

3. Enter your weight (1–350) and then your age (1–99).

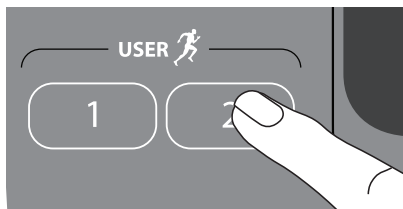
**Note:** To change a value (program, time, weight, or age) that you have already entered press RESET to return to the Precor banner. Select a program and reenter the appropriate values.

4. Hold onto a handrail. The ramp automatically changes to the CrossRamp set for your program.

**Note:** When you select a program without an identifying USER key, you enter the program as a guest user. Cumulative workout statistics and your preferences for weight, age, and gender are not stored in memory. To save this type of information, refer to *Selecting a User Key*.

5. Use the CROSSRAMP and RESISTANCE arrow keys to change the ramp incline and resistance.
6. Find a comfortable stride rate between 100 and 150 strides per minute.

## Selecting a User Key



To start your exercise session using personal identification and preferences set up in *Adding a User*, take the following steps:

1. At the Precor banner, press the same USER key you designated in step 1, *Adding a User*.

**Note:** Refer to *User Identification* if you have not previously chosen a USER key.

A welcome greeting scrolls across the display and the last program associated with the USER key appears. User preferences such as weight, age, and gender are reinstated.

The time goal associated with the displayed program also applies.

2. Press OK to select the program being displayed or choose another program using the PROGRAMS keypad. Refer to *Selecting a Program* for information about how to choose a program.

**Important:** If you make an entry error, press *RESET* to return to the Precor banner.

3. The display prompts you for a workout time. To adjust the time, use the number keypad or the navigational arrow keys. To accept the number appearing on the display, press OK.
4. Begin pedaling.
5. Use the *CROSSRAMP* and *RESISTANCE* arrow keys to change the ramp incline and resistance.
6. Find a comfortable stride rate between 100 and 150 strides per minute.

## Cooling Down After a Workout

Incorporate a cool-down period into your workout to help lower your heart rate and minimize muscle stiffness or soreness.

**Note:** You cannot switch to a different program or change display options during the cool-down period. To alter the cool-down period time limit, refer to *Setting a Cool-Down Time Limit*.

When you complete a program with a time limit, you automatically enter a cool-down period. The resistance is reduced by 20%. To readjust the CrossRamp or resistance, press the arrow keys. To lower your heart rate, reduce your strides per minute.

A workout summary appears at the end of the cool-down period. Refer to *Ending a Workout*.

**Important:** *If you exit a program before completing it, the cool-down period is bypassed.*

To prematurely end the cool-down period, do the following:

1. Grasp a stationary handrail with one hand.
2. Press RESET to view the workout summary.
3. Press RESET again to return to the Precor banner.

**Important:** *Hold on to a stationary handrail. Step off the EFX when the lift has stopped moving.*

## Pausing During a Workout or the Cool-Down Period

Stop pedaling to pause anytime during a workout or during a cool-down period. The pause mode has a default time limit of 10 minutes. If you do not resume exercising during that time, the display returns to the banner.

**Note:** You can change the pause time limit by following the instructions found in *Changing EFX Settings*.

1. To pause, stop pedaling.

The center display indicates the amount of time remaining in pause mode.

2. To resume exercising from pause mode, begin pedaling.

When you pause a program, you can change your program selection. Refer to *Changing Programs in Mid-session*.

**Note:** While paused during the cool-down period, you cannot change to another program.

## Ending a Workout

**CAUTION:** Hold on to a stationary handrail when you near the end of your exercise session.

1. Slow your pedaling when you complete the cool-down period.

Use the Selection keys to display each workout statistic, such as TOTAL CALORIES or VERTICAL GAIN. The workout statistics include warm-up and cool-down periods. After ten minutes, the display automatically resets to the Precor banner.

A fitness score, associated with your fitness category, appears when you take the Fitness Test.

A heart rate analysis also appears, if you held onto the touch-sensitive handrail grips or wore a chest strap while exercising. Refer to *Heart Rate Analysis*.

**Note:** On the EFX5.35, the workout summary provides your cumulative workout statistics.

2. To return to the Precor banner before the 10 minutes elapse, press the RESET key.
3. Turn Off the EFX and lock the foot pedals in place with the locking pin.

**Important:** *Never leave children unsupervised around the EFX. Always turn Off and unplug the EFX when it is not in use. Lock the foot pedals in place with the locking pin.*



# Programs

This section describes the programs available on the EFX. Use this section as a reference tool to better understand each program's purpose. For more information, refer to *Selecting a Program*.

The program descriptions are presented in menu selection order. To see a list of programs, refer to *PROGRAMS Keypad* and Table 2.

## Choosing a Program

Choosing a program depends on your goals. If you are a beginner or returning to regular exercise, you can start a cardio-conditioning program to slowly return your body to a comfortable level of exercise. If you have been exercising and feel that you have an intermediate or advanced fitness level, you probably have established goals. The Precor web site ([www.precor.com](http://www.precor.com)) can give you many ideas about fitness workouts and advice from the experts.

Several exercise choices on the EFX are pre-programmed with recommendations for CrossRamp, resistance and alternating interval levels. You always have the option to override the suggested levels with the exception of the Basic HRC and Fitness Test.

## Changing Programs in Mid-session

You can change programs in the middle of a session by selecting a new program from the PROGRAMS key menu. All accumulated workout statistics are transferred to the new program as you continue exercising.

Certain programs, such as the Fitness Test, Basic HRC, Fat Burner, and Aerobic Endurance, are not available for mid-session transfers due to set goals and program preferences. If this occurs, a message scrolls across the center display.

## Program Tips

- Begin at the Precor banner. Refer to *Workout Options*.
- A blinking column indicates your position as you progress through a program.
- To use the SmartRate feature, you need to specify your age and wear a chest strap or hold on to the touch-sensitive handrail grips. Refer to *Using SmartRate*.
- To exercise indefinitely in any program (except preset programs, such as the Fitness Test, Fat Burner, Weight Loss, and Aerobic Endurance), an unlimited exercise time setting may be an available option. Refer to *Selecting a Program*.
- If your level of exertion becomes too great, reduce your strides per minute and change the CrossRamp or resistance settings using the arrow keys to override each upcoming column in the program profile.
- To pause during a program, stop pedaling. Refer to *Pausing During a Workout or the Cool-Down Period*.
- When you complete a program that contains a time or calorie goal, the automatic cool-down period begins. Refer to *Cooling Down After a Workout*.
- Default time limits exist for the cool-down period and pause mode. Refer to *Changing EFX Settings* if you wish to adjust the settings.
- Cumulative workout statistics appear when you end your exercise session. Refer to *Ending a Workout*.

## Manual Program



The Manual Program profile, available by pressing the MANUAL key, begins as a flat line. You control CrossRamp and resistance settings using the CROSSRAMP or RESISTANCE arrow keys. The program profile reflects changes in all subsequent columns. The blinking column indicates your position in the program. A cool-down period occurs automatically when you complete your specified time goal.

**Note:** An exception to the cool-down period exists. Refer to *Advanced Programming and Troubleshooting* for more information.

To use the SmartRate feature, you need to specify your age during the setup prompts.

## Interval Program



The Interval Program, available by pressing the INTERVAL key, is one of the best for conditioning your cardiovascular system. The program raises and lowers your level of exertion repeatedly for the specified period of time.

Initially, the rest interval is set to a CrossRamp of 4 and a resistance of 1. The work interval is set at a CrossRamp of 10 and a resistance of 8. The display lets you know when the preset levels are about to change and it indicates the levels of the next interval.

While exercising, you can vary your strides per minute and change the preset ramp incline and resistance settings using the CROSSRAMP or RESISTANCE arrow keys. The settings are repeated throughout the remainder of the program. When you complete the program the CrossRamp and resistance settings return to their standard defaults. No settings, established during your exercise session, are saved.

## Aerobic Endurance Program



The Aerobic Endurance Program can be accessed by pressing the VARIETY key. The 30 to 60 minute program has been designed by Dr. Emily Cooper of Seattle Performance Medicine ([www.spmedicine.com](http://www.spmedicine.com)) to enhance muscular and aerobic endurance. It has a warmup period followed by gradually increasing CrossRamp inclines and resistance.

During the warmup period, the display prompts you to maintain a specific stride rate which increases muscle flexibility and raises your heart rate. When the program begins, maintain the recommended stride rate of 140 strides per minute to improve cardiopulmonary conditioning and muscular endurance. The ramp incline varies throughout the program every three minutes. When you complete the program, a 3-minute, cool-down period begins.

The CrossRamp and resistance are preset based on your body weight and the recommended strides per minute, but you have the option to adjust either one during the program using the arrow keys. If you make adjustments, you may change the effectiveness of the program.

## Hill Climb Program



The Hill Climb Program, available by pressing the VARIETY key, has preprogrammed CrossRamp settings in a fixed pattern. It is designed to increase muscle tone, cardio-conditioning, and endurance over several weeks.

The program consists of alternating forward and backward pedaling movements that focus on working the thigh and calf muscle groups. Display prompts appear indicating when to reverse pedal direction at select intervals: 25%, 50%, and 75% of program completion.

During your exercise session, you can change your strides per minute and override the CrossRamp or resistance settings using the arrow keys.

## Heart Rate Programs



The Basic HRC Program, available by pressing the HEART RATE key, adjusts the CrossRamp to maintain your heart rate within two beats per minute of the target heart rate while you exercise. To use this program, you must enter your age and wear a chest strap or grasp the touch-sensitive handrail grips so your heart rate can be monitored throughout the session.

**Important:** Consult your physician to determine the appropriate target heart rate for your age and fitness level. If your physician recommends a different target heart rate than the one that appears on the display adjust it accordingly. Do not exercise over the recommended range of 85% of your maximum aerobic heart rate.

### Heart Rate Program Tips

The Basic HRC Program enhances your overall cardiovascular fitness level to help you achieve your weight loss and fitness goals. Read through the following tips before selecting a program. These tips provide general information regarding how the program functions. For more information and exercise suggestions, refer to the Precor web site at [www.precor.com](http://www.precor.com).

- Each program provides a 3-minute warm-up period. During this time, you may change the CrossRamp or resistance, but you cannot adjust the time or change to a distance or calorie goal. At the end of the warm-up period, the program automatically controls the resistance. Pressing the RESISTANCE arrow keys has no effect.

**Note:** When your target heart rate is achieved or the 3-minute period elapses, the warm-up period ends and the program begins.

- The program sets the target heart rate as a percentage of 220 minus your age. Changing the target heart rate your stride rate or CrossRamp affects the unit's ability to maintain your target heart rate in the preferred zone. It takes time for the EFX to readjust the resistance so that your heart rate remains on target. Check the SmartRate and the HEART RATE displays to see if you are maintaining your preferred zone and to determine your actual heart rate. For information about understanding your target heart rate, refer to *Heart Rate Features*.
- Changes to the CrossRamp are reflected in the program's profile. Automatic resistance changes appear in the RESISTANCE display.
- To change the program, select a different PROGRAMS key and press OK.
- A cool-down period is incorporated into the program.

## Fitness Test Program



The Fitness Test, available by pressing the HEART RATE key, is a test that consists of three 5-minute sessions. A warm-up and cool-down period is incorporated into the program. The actual duration of the test ranges between 5 and 23 minutes depending on your fitness level. You cannot adjust the CrossRamp or resistance settings.

The Fitness Test measures the maximum amount of oxygen ( $VO_2$  max) the body can use for energy production during exercise. The higher the amount of oxygen that your body can use enhances your ability to exercise for prolonged periods of time. The test results can help you gauge the effectiveness of your current exercise routine and tailor it to meet your fitness goals.

**Important:** *You must wear the chest strap or grasp both touch-sensitive handrail grips throughout the Fitness Test. If the heart rate reception is erratic, incorrect readings can occur and terminate the test.*

During the test, the EFX maintains the CrossRamp setting at 4 and gradually increases the resistance in specific stages. The display may request that you change your stride rate.

The keypads are disabled. The test ends if,

- You press RESET.
- Two minutes has elapsed since the last heart rate signal was received.
- After warm up, if you surpass your target heart rate (74% of your maximum aerobic heart rate).
- You stop pedaling and the pause time limit elapses.

You must complete the test for it to determine your aerobic capacity and establish your  $VO_2$  max. Once you complete the test, a fitness score and fitness level appear as part of the workout summary. Use it to compare to Table 3 or Table 4.

## Fitness Test Tips

Read through the following tips before selecting the Fitness Test.

- Sit and rest for at least five minutes prior to taking the test.
- You must enter your weight, age, and gender.
- You can change to another program while in the midst of taking the Fitness Test, but you will not receive a fitness score.
- If you press the RESET key during the test, the test ends and the display indicates whether the test was completed.

**Important:** If you need to stop the pedaling to regain control or reduce your heart rate, please do so. You can retake the fitness test later.

## Fitness Test Scores

The display prompts you to begin a cool down period when you finish the Fitness Test. A fitness score and a fitness level appear on the display as part of the workout summary and relate to the tables shown below.

**Note:** A fitness score appears only if you complete at least two stages of the test.

**Table 3. Cardio respiratory Fitness Score Category–Females\***

Age in Years	Fitness Category		
	Low Fitness	Medium Fitness	High Fitness
20–39	28 (or below)	28–33	33 (or above)
40–49	26 (or below)	26–31	31 (or above)
50–59	24 (or below)	24–28	28 (or above)
60 and over	22 (or below)	22–26	26 (or above)

\* The test and analysis algorithm were developed by Dr. Emily Cooper of Seattle Performance Medicine ([www.spmmedicine.com](http://www.spmmedicine.com)).

**Table 4. Cardio respiratory Fitness Score Category–Males\***

Age in Years	Fitness Category		
	Low Fitness	Medium Fitness	High Fitness
20–39	35 (or below)	35–42	42 (or above)
40–49	32 (or below)	32–39	39 (or above)
50–59	29 (or below)	29–36	36 (or above)
60 and over	24 (or below)	24–31	31 (or above)

\* The test and analysis algorithm were developed by Dr. Emily Cooper of Seattle Performance Medicine ([www.spmmedicine.com](http://www.spmmedicine.com)).

## Weight Loss Programs



The Weight Loss Programs, available by pressing the WEIGHT LOSS key, provide a variety of programs targeted at lowering body fat while improving muscle tone and conditioning.

Anytime during your exercise session you can use the CROSSRAMP or RESISTANCE arrow keys to override upcoming segments.

The chart below briefly explains the purpose of each program.

<b><i>Program</i></b>	<b><i>Description</i></b>
Fat Burner	This program has been designed by Dr. Emily Cooper of Seattle Performance Medicine ( <a href="http://www.spmedicine.com">www.spmedicine.com</a> ) to improve fat-burning results and increase endurance every time you exercise. The program incorporates warm-up and cool-down periods and allows you to select a program time between 30 and 90 minutes. Work and rest intervals appear along with recommended stride rates. The faster pace stride rates, combined with fairly low resistance levels, provides optimal oxygenation to the working muscles. The display prompts you when you need to make changes in your stride rate. To monitor your heart rate during the program, use the touch-sensitive handrail grips or wear a chest strap. Refer to <i>Heart Rate Features</i> .
Weight Loss Interval	Use this program if you are beginning or returning to a regular fitness routine. The workout time is fixed at 28 minutes and consists of seven 4-minute intervals. You are not prompted for a workout time.



## Gluteal Program



The Gluteal Program, available by pressing the PERFORMANCE key, is designed to exercise your gluteal muscles. The CrossRamp is preprogrammed and display prompts appear indicating when to reverse pedal direction at select intervals: 25%, 50%, and 75% of program completion.

During your workout, set a comfortable and consistent stride rate. If needed, use the CROSSRAMP or RESISTANCE arrow keys to override upcoming segments. Any adjustments to the CrossRamp or resistance are applied to upcoming segments. CrossRamp changes are reflected in the program profile.

To change the program, select a different PROGRAMS key and press OK.

## CrossTrainer Program



The CrossTrainer Program, available by pressing the PERFORMANCE key, has preprogrammed CrossRamp and resistance settings.

The program consists of alternating forward and backward pedaling movements that focus on working the thigh and calf muscle groups. Display prompts appear indicating when to reverse pedal direction at select intervals: 25%, 50%, and 75% of program completion.

During your workout, set a comfortable stride rate. If needed, use the CROSSRAMP or RESISTANCE arrow keys to override upcoming segments. Any adjustments to the CrossRamp or resistance are applied to upcoming segments. CrossRamp changes are reflected in the program profile.

To change the program, select a different PROGRAMS key and press OK.

# Advanced Programming and Troubleshooting

Certain features remain hidden and can only be accessed using special key presses. Read this section if you want to:

- Select the units of measure
- Set the pause or cool-down times
- Determine the setting for the CrossRamp auto-leveling feature
- View the odometer
- Display the number of hours you have used your EFX
- View the software versions and part numbers
- Check the usage log
- Check the error log

## Advanced Programming Tips

- Always start at the Precor banner.
- The advanced programming and diagnostic mode is accessed by pressing the RESET key at the Precor banner. Any remaining key presses must occur quickly and without pause.
- The QUICKSTART key is disabled while in advanced programming mode.
- The number keypad is disabled once you enter advanced programming mode. You need to use the navigational arrow keys to change the blinking prompts.
- Some keys provide the same functionality and can be used interchangeably while in advanced programming mode. These keys are:  
OK and ENTER
- The advanced programming prompts appear sequentially and in a menu format. Pressing the arrow keys in the navigational keypad moves you through the programs. Press OK to choose or accept the displayed selection. To return to the Precor banner without saving any changes, press RESET.

## Changing EFX Settings

Through a specific set of number key presses, you can customize the pause or cool down times.

To access the menu and change the settings, perform the following steps:

1. At the Precor banner, press the following keys in sequence without pausing between selections:

RESET, 5, 6, 7, 1

Numbers appear on the display as you press the associated key.

DIAGS - SET PARAMETERS appears briefly, and then SELECT UNITS scrolls across the display.

## Selecting a U.S. Standard or Metric Display

The EFX can display measurements in either metric or U.S. standard. The default factory setting is set to display U.S. standard. To change this setting, perform the following steps:

2. At the SELECT UNITS prompt, press OK. Use the navigational arrow keys to select a unit of measure (either METRIC or U.S.).
3. When you are ready, press OK to accept the displayed setting and move to the next program. Or, press RESET to cancel any changes and return to the Precor banner.

## Setting a Pause Time Limit

You can limit how long a user can pause while exercising on the unit by entering a time between 1 and 10 minutes. For example, if you set the pause time limit to 60 seconds, the display automatically resets to the Precor banner if no key press occurs within one minute.

4. At the SET MAX PAUSE TIME prompt, press OK. Use the navigational arrow keys to change the time limit. Choose between 1 and 10 minutes. The default time is 10 minutes.
5. When you are ready, press OK to accept the displayed setting and move to the next program. Or, press RESET to cancel any changes and return to the Precor banner.

## Setting a Cool-Down Time Limit

You can limit how long a user cools down after exercising on the unit by entering a time between 0 and 5 minutes.

**Important:** *It is highly recommended that you set the cool-down period at or above three minutes. It takes time for a user's heart rate to return to a resting state after vigorous exercise. An effective cool-down period also reduces the amount of lactic acid in muscle tissue.*

6. At the SET COOL DOWN TIME prompt, press OK. Use the navigational arrow keys to display the available time limits. The default setting is 5 minutes.
7. When you are ready, press OK to accept the displayed setting and move to the next program. Or, press RESET to cancel changes and return to the Precor banner.

## Setting the CrossRamp Auto-Reset Feature

The EFX has an auto-reset feature. The ramp resets to a specific incline level when you begin your exercise session and choose a program that has a different initial CrossRamp setting than the previously used program.

8. At the SET CROSSRAMP prompt, press OK. Use the navigational arrow keys to select the desired ramp incline level between 1 and 20 on the EFX5.35 and between 1 and 14 on the EFX5.33 or EFX5.31.
9. When you are ready, press OK to accept the displayed setting and return to the SELECT UNITS prompt. Or, press RESET to cancel changes and return to the Precor banner.

## Informational Displays

The EFX provides information about its use (odometer and hour meter), as well as software version, usage log, and error codes. In general, you would only access this information if directed to do so by Precor Customer Support.

These instructions guide you through all eight informational displays. Pressing the OK key moves you through the displays. Pressing the navigational arrow keys cycles you through the menu selection. To exit, press RESET at any time.

## Viewing the Odometer

1. At the Precor banner, press the following keys in sequence and without pause:  
RESET, 6, 5

The numbers 6, 5 appear on the display as you press the associated key.

Then DIAGS - INFORMATION DISPLAY scrolls across the display followed by ODOMETER.

2. Press OK to view the odometer value (cumulative strides traveled) or press the ▼ arrow key to move to the next informational display.
3. When you are ready, press OK to move to the next display (hour meter).

## Viewing the Hour Meter

HOUR METER scrolls across on the display.

4. Press OK to view the number of hours that the unit has been in use or press the ▼ arrow key to move to the next informational display.

The EFX tracks the elapsed minutes, but the value that appears is truncated to the nearest full hour.

5. When you are ready, press OK to move to the next display (software version).

## Viewing the Software Part Numbers

U-BOOT SW scrolls across the display.

6. Press OK to view the upper board boot software part number (for example, 48996-100) or press the ▼ arrow key to move to the next informational display.
7. When you are ready, press OK to move to the next display (upper base application software part number).  
U-BASE SW scrolls across the display.
8. Press OK to view the upper base application software part number or press the ▼ arrow key to move to the next informational display.

9. When you are ready, press OK to move to the next display (lower board's software part number).

LOWER SW scrolls across the display.

10. Press OK to view the lower board software version and part number.

11. When you are ready, press OK to move to the next display (metrics board's software part number).

METRICS BOARD SW PART NUMBER scrolls across the display.

12. Write the numbers below. You will need these numbers if you call Customer Support with questions. This information will help rule out any software-related problems:

UPPER BOOT SW: \_\_\_\_\_

UPPER BASE SW: \_\_\_\_\_

LOWER SW: \_\_\_\_\_

METRICS BOARD SW: \_\_\_\_\_

13. When you are ready, press OK to move to the next display (usage log).

## Viewing the Usage Log

USAGE LOG scrolls across the display.

14. When you are ready, press OK to view each program, the number of times it has been used, and the associated cumulative minutes. The usage log is helpful in determining user preferences in program selection.
15. Use the navigational arrow keys to select and view usage information about each specific program.

**Note:** For a list of programs, refer to *PROGRAMS Keypad* and Table 2.

16. When you are ready, press OK to move to the next display (error log).

## Viewing the Error Log

ERROR LOG scrolls across the display.

17. When you are ready, press OK to determine how many errors exist in the error log or press the ▼ arrow key to cycle back to the ODOMETER display.

**Note:** If there are no errors in the log, you will see NO ERRORS displayed. When you press OK, you return to the ODOMETER display.

18. Press OK again to view the first entry in the error log.
19. To move through the error log, continue to press the ▼ arrow key. Each error code specifies when it occurred, listing the error code, odometer, hour meter and current (amps) values.

**Note:** Use the ▲ arrow key to review prior error log entries. To exit the error log, press OK while the code scrolls across the display.

20. Copy the error code information to paper so you can provide it to Customer Support if needed. Be sure to copy it exactly as shown.

21. When you no longer need the information in the error log, press QUICKSTART for at least four seconds to erase it. The message, NO ERRORS, appears on the display and remains static to let you know when the error log has been cleared.

**Important:** You cannot retrieve the error log once you have cleared it. You may want to resolve any issues you are experiencing with the EFX before clearing the error log.

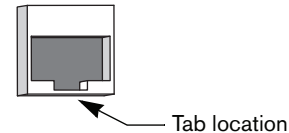
22. When you are ready, press OK to cycle back to the ODOMETER, or press RESET to return to the Precor banner.

## Troubleshooting Error Codes

If any error codes appear in the center display, turn the unit Off and On. If the error continues to occur, call an authorized service person for assistance. Refer to *Obtaining Service*.

If ERROR 30 appears on the display, you have an incorrect RJ45 cable connection. Remove the cable and re-insert it into the other receptacle on the back of the display console. The correct receptacle has the tab opening at its base.

For example:





## Troubleshooting Heart Rate

Table 5 may help you understand and troubleshoot erratic heart rate readings.

**Important:** A heart rate can only be detected when the EFX is turned On and you wear the chest strap or hold on to both touch-sensitive handrail grips.

To conduct electrical impulses from a user's heart, both touch-sensitive handrail grips must be grasped firmly for five to ten seconds. Usually, the concentration of salts in a person's perspiration provides enough conductivity to transmit a signal to the receiver in the display console. However, because of body chemistry or erratic heartbeats, some people cannot use the heart rate feature. A chest strap may provide better results. Refer to the *QuickStart Card* for proper placement of the chest strap.

**Table 5. Erratic heart rate readings**

<i>What appears on the display</i>	<i>Cause</i>	<i>What to Do</i>
Nothing	The heart rate receiver is not installed or it has been disconnected.	To receive Customer Support, refer to <i>Obtaining Service</i> .
---	A signal is being detected, but the transmission requires more time to establish a heart rate.	Be sure the chest strap is in direct contact with your skin.
Hr	A signal is being detected, but the transmission requires more time to establish a heart rate.	If using the touch-sensitive handrail grips, use both hands and make sure your hands are moist, not dry.
Pulsing HEART	The LED heart blinks when a heart beat is detected.	If the LED is pulsating, it indicates that the heart rate equipment is working properly.

# Maintenance

It is important to perform the minor maintenance tasks described in this section. Failure to maintain the EFX as described here could void the Precor Limited Warranty.

**DANGER** To reduce the risk of electrical shock, always unplug the unit from its power source before cleaning it or performing any maintenance tasks.

## Inspection

### Inspect the EFX before use.

Look and listen for slipping belts, loose fasteners, unusual noises, worn or frayed power cords, and any other indications that the equipment may be in need of service. If you notice any of these, obtain service.

**Important:** *If you determine that the EFX needs service, make sure that the EFX cannot be used inadvertently. Turn the unit Off, insert the locking pin and then unplug the power cord from its power source. Make sure other users know that the EFX needs service.*

To order parts or to contact a Precor authorized service provider in your area, refer to *Obtaining Service*.

## Cleaning the Equipment

Most of the working mechanisms are protected inside the covers. However, for efficient operation, the EFX relies on low friction. To keep the friction low, the unit's rollers, ramp, foot pedals, handlebars, and covers must be as clean as possible.

Precor recommends the EFX be cleaned before and after each workout. Use mild soap and water; dampen a soft cloth and wipe all exposed surfaces. This helps remove any dust or dirt.

**CAUTION:** Do not use any acidic cleaners. Doing so will weaken the paint or powder coatings and void the Precor Limited Warranty. Never pour water or spray liquids on any part of the EFX. Allow the EFX to dry completely before using.

Frequently vacuum the floor around the unit to prevent the accumulation of dust and dirt, which can affect the smooth operation of the unit. Use a soft nylon scrub brush to clean the foot pedals.

## **Storing the Chest Strap**

Store the chest strap in a place where it remains free of dust and dirt such as, in a closet or drawer. Be sure to protect the chest strap from extremes in temperature. Do not store it in a place that may be exposed to temperatures below 32° F (0° C).

To clean the chest strap, use a sponge or soft cloth dampened in mild soap and water. Dry the surface thoroughly with a clean towel.

## **Long-Term Storage**

When the EFX is not in use for any length of time, turn it Off. Make sure that the power cord is unplugged from its power source and is positioned so that it will not become damaged or interfere with people or other equipment.

# Precor Residential Equipment Limited Warranty

PLEASE READ THESE WARRANTY TERMS AND CONDITIONS CAREFULLY BEFORE USING YOUR PRECOR INCORPORATED PRODUCT. BY USING THE EQUIPMENT, YOU ARE CONSENTING TO BE BOUND BY THE FOLLOWING WARRANTY TERMS AND CONDITIONS.

## Limited Warranty

Precor Incorporated warrants all new Precor products to be free from defects in materials and manufacture for the warranty period set forth below. The warranty period commences on the invoice date of original purchase. This warranty applies only against defects discovered within the warranty period and extends only to the original purchaser of the product. Parts repaired or replaced under the terms of this warranty will be warranted for the remainder of the original warranty period only. To make claim under warranty, the buyer must notify Precor or their authorized Precor dealer within 30 days after the date of discovery of any nonconformity and make the affected product available for inspection by Precor or its service representative. Precor's obligations under this warranty are limited and set forth below.

## Warranty Periods and Coverage

All residential products and commercial products used in the home are warranted for the following periods:

- Lifetime frame and welds
- 10 years parts and wear items
- 1 year labor
- Coverage for options and accessories defined below.

## Options / Accessories

Many options or accessories have components that are connected internally or mounted inside the electronic console. The following guidelines determine the warranty for these components. If the internal components are installed by the factory or by an authorized dealer as part of the original sale and delivery, they have a warranty that is identical to the warranty of the equipment in which they are connected or mounted. If the internal components are not installed by the factory or by an authorized dealer as part of the original sale and delivery, they have a 90-day parts and labor limited warranty. All components that are not internally connected have 90-day parts only limited warranty. Satisfactory proof of purchase is required in all cases.

## Conditions and Restrictions

This warranty is valid only in accordance with the conditions set forth below:

1. The warranty applies to the Precor product only while:
  - a. It remains in the possession of the original purchaser and proof of purchase is demonstrated
  - b. It has not been subjected to accident, misuse, abuse, improper service, or non-Precor modifications
  - c. Claims are made within the warranty period
2. This warranty does not cover damage or equipment failure caused by electrical wiring not in compliance with electrical codes or Precor owner's manual specifications, or failure to provide reasonable and necessary maintenance as outlined in the owner's manual.

3. Warranty of all Precor products applies to residential use only and is void when products are used in a nonresidential environment or installed in a country other than where sold.
4. Except in Canada, Precor does not pay labor outside the United States.
5. Warranties outside the United States and Canada may vary. Please contact your local Dealer for details.

### **This limited warranty shall not apply to:**

1. Software version upgrades
2. Cosmetic items, including, but not limited to the following: grips, seats, and labels.
3. Repairs performed on Precor equipment missing a serial number or with a serial tag that has been altered or defaced.
4. Service calls to correct installation of the equipment or instruct owners on how to use the equipment.
5. Pickup, delivery, or freight charges involved with repairs.
6. Any labor costs incurred beyond the applicable labor warranty period.

### **Disclaimer and Release**

The warranties provided herein are the exclusive warranties given by Precor and supersede any prior, contrary or additional representations, whether oral or written. ANY IMPLIED WARRANTIES, INCLUDING THE WARRANTY OF MERCHANTABILITY OR FITNESS FOR A PARTICULAR PURPOSE THAT APPLY TO ANY PARTS DESCRIBED ABOVE ARE LIMITED IN DURATION TO THE PERIODS OF EXPRESS WARRANTIES GIVEN ABOVE FOR THOSE SAME PARTS. PRECOR HEREBY DISCLAIMS AND EXCLUDES THOSE WARRANTIES THEREAFTER. Some states do not allow limitation on how long an implied warranty lasts, so the above limitation may not apply to you.

PRECOR ALSO HEREBY DISCLAIMS AND EXCLUDES ALL OTHER OBLIGATIONS OR LIABILITIES, EXPRESS OR IMPLIED, ARISING BY LAW OR OTHERWISE, WITH RESPECT TO ANY NONCONFORMANCE OR DEFECT IN ANY PRODUCT, INCLUDING BUT NOT LIMITED TO: (A) ANY OBLIGATION, LIABILITY, RIGHT, CLAIM OR REMEDY IN TORT, WHETHER OR NOT ARISING FROM THE NEGLIGENCE OF PRECOR OR ITS SUPPLIERS (WHETHER ACTIVE, PASSIVE OR IMPUTED); AND (B) ANY OBLIGATION, LIABILITY, RIGHT, CLAIM, OR REMEDY FOR LOSS OF OR DAMAGE TO ANY EQUIPMENT. This disclaimer and release shall apply even if the express warranty set forth above fails of its essential purpose.

### **Exclusive Remedies**

For any product described above that fails to conform to its warranty, Precor will provide, at their option, one of the following: (1) repair; (2) replacement; or (3) refund of the purchase price. Precor Limited Warranty service may be obtained by contacting the authorized dealer from whom you purchased the item. Precor compensates Servicicers for warranty trips within their normal service area to repair equipment at the owner's location. You may be charged a trip charge outside the service area. THESE SHALL BE THE SOLE AND EXCLUSIVE REMEDIES OF THE BUYER FOR ANY BREACH OF WARRANTY.

## **Exclusion of Consequential and Incidental Damages**

PRECOR AND/OR ITS SUPPLIERS SHALL HAVE NO OBLIGATION OR LIABILITY, WHETHER ARISING IN CONTRACT (INCLUDING WARRANTY), TORT (INCLUDING ACTIVE, PASSIVE, OR IMPUTED NEGLIGENCE AND STRICT LIABILITY), OR OTHERWISE, FOR DAMAGE TO THE EQUIPMENT, PROPERTY DAMAGE, LOSS OF USE, REVENUE OR PROFIT, COST OF CAPITAL, COST OF SUBSTITUTE EQUIPMENT, ADDITIONAL COST INCURRED BY BUYER (BY WAY OF CORRECTION OR OTHERWISE) OR ANY OTHER INCIDENTAL, SPECIAL, INDIRECT, OR CONSEQUENTIAL DAMAGES, WHETHER RESULTING FROM NONDELIVERY OR FROM THE USE, MISUSE OR INABILITY TO USE THE PRODUCT. This exclusion applies even if the above warranty fails of its essential purpose and regardless of whether such damages are sought for breach of warranty, breach of contract, negligence, or strict liability in tort or under any other legal theory. Some states do not allow the exclusion or limitation of incidental or consequential damages, so the above limitation might not apply.

This warranty gives you specific legal rights, and you may also have other rights, which vary state to state.

Effective 01 January, 2003  
P/N 36287-110

*Notes:*

*Notes:*



**Thank You and Welcome to Precor**

**PRECOR**<sup>®</sup><sub>USA</sub>  
**move beyond**<sup>®</sup>

To allow us to serve you better, please take a few moments to complete and return your warranty registration.

**YOU MAY ALSO REGISTER ONLINE AT**

**[www.precor.com/warranty](http://www.precor.com/warranty)**

If you have questions or need additional information, contact your local dealer or call Precor Customer Support at 800-347-4404.

Fold along dotted line and tape closed before mailing.

RET.

**PRECOR**<sup>®</sup><sub>USA</sub>  
Precor Incorporated  
20031 142nd Avenue NE  
PO Box 7202  
Woodinville, WA 98072-4002

PLACE  
STAMP  
HERE

**TELL US ABOUT YOUR NEW PRECOR PRODUCT**

**Date of Purchase:** \_\_\_\_\_  
Month Day Year

**Product Serial Number:** \_\_\_\_\_  
The serial number is located on the shipping box and on the product.

**Purchased from:** \_\_\_\_\_  
Dealer Name

- Please indicate the type of product purchased:**
- Elliptical Fitness CrossTrainer™ (EFX®)
  - Treadmill
  - Strength Training System
  - StretchTrainer™
  - Cycle
  - Stair Climber

**TELL US ABOUT YOU**

Mr.  
 Mrs.  
 Ms.

\_\_\_\_\_  
First Name Middle Initial Last Name

\_\_\_\_\_  
Street Address Apt./Suite:

\_\_\_\_\_  
City State Zip Code

\_\_\_\_\_  
Area Code Telephone

\_\_\_\_\_  
Your Email Address

- |                                 |   |                                   |  |  |
|---------------------------------|---|-----------------------------------|--|--|
| <b>Gender:</b>                  | <b>Marital status:</b>                      | <b>Age:</b>                       | <b>Annual household income:</b>            | <b>What are your fitness goals?</b>                      |
| <input type="checkbox"/> Male   | <input type="checkbox"/> Married            | <input type="checkbox"/> Under 18 | <input type="checkbox"/> Under \$50,000    | <input type="checkbox"/> Weight loss/management          |
| <input type="checkbox"/> Female | <input type="checkbox"/> Divorced           | <input type="checkbox"/> 18-24    | <input type="checkbox"/> \$51,000-75,000   | <input type="checkbox"/> Muscle tone enhancement         |
|                                 | <input type="checkbox"/> Widowed            | <input type="checkbox"/> 25-34    | <input type="checkbox"/> \$76,000-100,000  | <input type="checkbox"/> Cardiovascular improvement      |
|                                 | <input type="checkbox"/> Never been married | <input type="checkbox"/> 35-44    | <input type="checkbox"/> \$101,000-150,000 | <input type="checkbox"/> Overall health                  |
|                                 |   | <input type="checkbox"/> 45-54    | <input type="checkbox"/> \$151,000+        | <input type="checkbox"/> Increase energy and flexibility |
|                                 |   | <input type="checkbox"/> 55-64    |  | <input type="checkbox"/> Stress reduction                |
|                                 |   | <input type="checkbox"/> 65+      |  | <input type="checkbox"/> Rehabilitation                  |
|                                 |   |                                   |  | <input type="checkbox"/> Other                           |

**TELL US ABOUT YOUR PURCHASE**

- Purchase (check all that apply):**
- First Precor product
  - Replaces a Precor product of the same type
  - Replaces same type of product – different brand
  - Addition to equipment currently owned
- What factors MOST influenced your decision to purchase your Precor product (choose up to three):**
- Precor reputation
  - Prior use of Precor product(s)
  - Design/appearance
  - Special product features
  - Physician recommendation
  - Rebate or sale price
  - Quality/durability
  - Warranty
  - Value for the price
- How did you FIRST become aware of Precor products (choose only one):**
- A gift
  - Friend/relative
  - Physician
  - Fitness club
  - Internet
  - News report or product review
  - Magazine advertisement or article
  - Print advertisement
  - In-store display or demonstration
  - Other

Effective 28 June 2004  
P/N 45623-102

Please detach and mail in the warranty registration within ten days of purchase.

## EFX5.35, EFX5.33, EFX5.31 Elliptical Fitness CrossTrainers™

### Product Specifications

	EFX5.35	EFX5.33	EFX5.31
Length:	84 in (213 cm)		
Width:	31 in (79 cm)		
Height:	63 in (159 cm)		
Weight:	240 lb (109 kg)	240 lb (109 kg)	210 lb (95 kg)
Shipping weight:	290 lb (123 kg)	290 (132 kg)	260 lb (118 kg)
Power:	120 VAC, 50/60Hz	120 VAC, 50/60Hz	120 VAC, 50/60Hz
CrossRamp®:	15° – 40°	15° – 30°	15° – 30°
Incline Settings:	1–20	1–20	1–20
Resistance Levels	1–20	1–20	1–20
Frame:	Powder-coated steel	Powder-coated steel	Powder-coated steel
Regulatory Approvals:	FCC, ETL, CE	FCC, ETL, CE	FCC, ETL, CE

### Product Features

CSAFE
QUICKSTART™
SmartRate®
Heart Rate Telemetry (chest strap optional on the 5.31)
Touch Heart Rate
User Keys (2)

### Programs

Manual	Weight Loss
Interval	Fat Burner
Variety	Weight Loss
Aerobic Endurance	Performance
Hill Climb	Gluteal
Heart Rate	CrossTrainer
Basic HRC*	
Fitness Test*	

### Electronic Readouts

% Complete	Strides per Minute
Average Heart Rate*	Target Heart Rate
Calories	Time
CrossRamp	Time Elapsed
Heart Rate*	Time in Heart Rate Zone*
Maximum Heart Rate*	Time Remaining
Profile	Total Strides
Resistance	Units
SmartRate*	Vertical Gain

\* Use of chest strap or touch-sensitive handrail grips is required.



Precor Incorporated  
20031 142nd Ave NE  
P.O. Box 7202  
Woodinville, WA USA 98072-4002  
1-800-347-4404

Precor, C, CrossRamp, EFX, M, Move Beyond, and SmartRate are registered trademarks of Precor Incorporated. Crosstrainer, QuickStart, and StretchTrainer are trademarks of Precor Incorporated. Copyright 2007 Precor Incorporated. Specifications subject to change without notice.  
[www.precor.com](http://www.precor.com)

**NOTICE:**

Precor is widely recognized for its innovative, award winning designs of exercise equipment. Precor aggressively seeks U.S. and foreign patents for both the mechanical construction and the visual aspects of its product design. Any party contemplating the use of Precor's product designs is hereby forewarned that Precor considers the unauthorized appropriation of its proprietary rights to be a very serious matter. Precor will vigorously pursue all unauthorized appropriation of its proprietary rights.

5.35/5.33/5.31 OM 34236-101, en  
Warranty # 36287-110, en  
Registration Card# 45623-102, en  
31 July 2007