

SANYO

INSTRUCTION MANUAL

TRC-6030

MEMO-SCRIBER Transcribing System

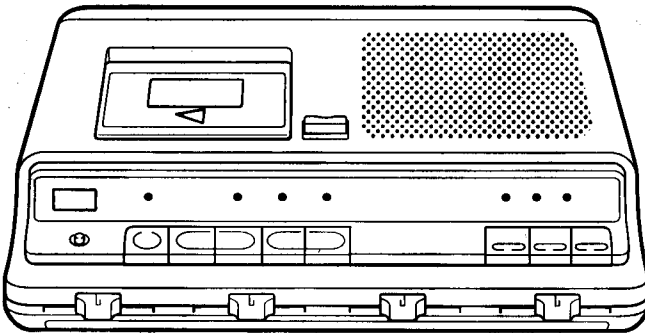

SANYO'S HELP-LINE

Call the toll-free number below if you have any difficulties operating this product.
1-800-421-5013 (weekdays 8:00 AM - 5:00 PM, pacific time)

**SANYO MEMO-SCRIBER
MODEL TRC-6030 LIMITED WARRANTY**

OBLIGATIONS

In order to obtain warranty service, the product must be delivered to and picked up from an Authorized Sanyo Service Center at the user's expense, unless specifically stated otherwise in this warranty. The names and addresses of Authorized Sanyo Service Centers may be obtained by writing to SFS Corporation, SFC's warranty administrator, at any of the addresses listed below, or by calling (toll-free) 1-800-421-5013.

New Jersey Office 210 Riser Road Little Ferry, NJ 07643 201-641-3000	California Office 1200 W. Artesia Blvd. Compton, CA 90220 310-537-5830	Illinois Office 900 N. Arlington Heights Road Itasca, IL 60143 708-775-1414	Georgia Office 1790 Corporate Drive, Suite 340 Norcross, GA 30093 404-925-8900
--	--	---	--

THIS WARRANTY IS VALID ONLY ON SANYO PRODUCTS PURCHASED OR RENTED AND USED IN THE UNITED STATES OF AMERICA, EXCLUDING HAWAII AND ALL U.S. TERRITORIES AND PROTECTORATES. THIS WARRANTY APPLIES ONLY TO THE ORIGINAL RETAIL USER, AND DOES NOT APPLY TO PRODUCTS USED FOR ANY INDUSTRIAL, PROFESSIONAL OR COMMERCIAL PURPOSE. THE ORIGINAL DATED BILL OF SALE, SALES SLIP OR RENTAL AGREEMENT MUST BE SUBMITTED TO THE AUTHORIZED SANYO SERVICE CENTER AT THE TIME WARRANTY SERVICE IS REQUESTED.

Subject to the OBLIGATIONS above and EXCLUSIONS below, SANYO FISHER (USA) CORPORATION (SFC) warrants this SANYO product against defects in materials and workmanship for the periods of LABOR and PARTS specified below. SFC will repair or replace (at its option) the product and any of its parts which fail to conform to this warranty. The warranty period commences on the date the product was first purchased or rented at retail.

LABOR	PARTS
90 DAYS	1 YEAR

EXCLUSIONS

This warranty does not cover (A) the adjustment of customer-operated controls as explained in the appropriate model's instruction manual, or (B) the repair of any product whose serial number has been altered, defaced or removed. This warranty shall not apply to the cabinet or cosmetic parts, knobs or routine maintenance. This warranty does not apply to uncrating, setup, installation, removal of the product for repair, or reinstallation of the product after repair.

This warranty does not apply to repairs or replacements necessitated by any cause beyond the control of SFC including, but not limited to, any malfunction, defect or failure caused by or resulting from unauthorized service or parts, improper maintenance, operation contrary to furnished instructions, shipping or transit accidents, modification or repair by the user, abuse, misuse, neglect, accident, incorrect line voltage, fire, flood or other Acts of God, or normal wear and tear. The foregoing is in lieu of all other expressed warranties and SFC does not assume or authorize any party to assume for it any other obligation or liability.

THE DURATION OF ANY WARRANTIES WHICH MAY BE IMPLIED BY LAW (INCLUDING THE WARRANTIES OF MERCHANTABILITY AND FITNESS) IS LIMITED TO THE TERM OF THIS WARRANTY. IN NO EVENT SHALL SFC BE LIABLE FOR SPECIAL, INCIDENTAL OR CONSEQUENTIAL DAMAGES ARISING FROM OWNERSHIP OR USE OF THIS PRODUCT, OR FOR ANY DELAY IN THE PERFORMANCE OF ITS OBLIGATIONS UNDER THIS WARRANTY DUE TO CAUSES BEYOND ITS CONTROL.

SOME STATES DO NOT ALLOW LIMITATIONS ON HOW LONG AN IMPLIED WARRANTY LASTS AND/OR DO NOT ALLOW THE EXCLUSION OR LIMITATION OF CONSEQUENTIAL DAMAGES, SO THE ABOVE LIMITATIONS AND EXCLUSIONS MAY NOT APPLY TO YOU.

THIS WARRANTY GIVES YOU SPECIFIC LEGAL RIGHTS. YOU MAY HAVE OTHER RIGHTS, WHICH VARY FROM STATE TO STATE.

S/A R9 (M)

ATTENTION

For your protection in the event of theft or loss of this product, please fill in the information below for your own personal records.

Model No. _____ Serial No. _____
(Located on back or bottom side of unit)

Date of Purchase _____ Purchase Price _____

Where Purchased _____

WARNING: TO PREVENT FIRE OR SHOCK HAZARD, DO NOT EXPOSE THIS APPLIANCE TO RAIN OR MOISTURE.

CONTROLS

1. Eject lever (EJECT)
2. Cassette compartment lid
3. Tape counter and reset button (COUNTER/RESET)
4. Backspace control (BACKSPACE)
5. Erase button and indicator (ERASE)
6. Stop button (STOP)
7. Play button and indicator (PLAY)
8. Speed control (SPEED)
9. Fast forward button and indicator (FFWD)
10. Rewind button and indicator (REW)
11. Volume control (VOLUME)
12. Search button and indicator (SEARCH)
13. Tone control (TONE)
14. Speed select button and indicators (SPEED)
15. Power button (POWER)
16. Speaker
17. External DC 9V jack (EXT DC 9V)
18. Remote control jack (REMOTE)
19. Earphone jack (EARPHONE)

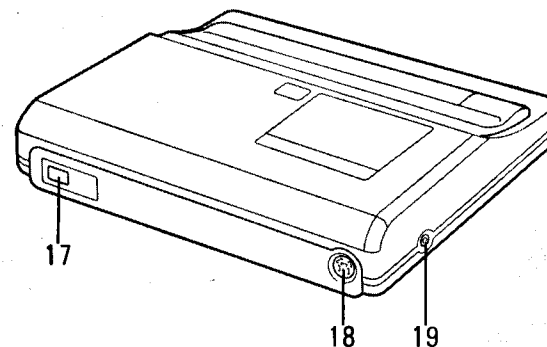
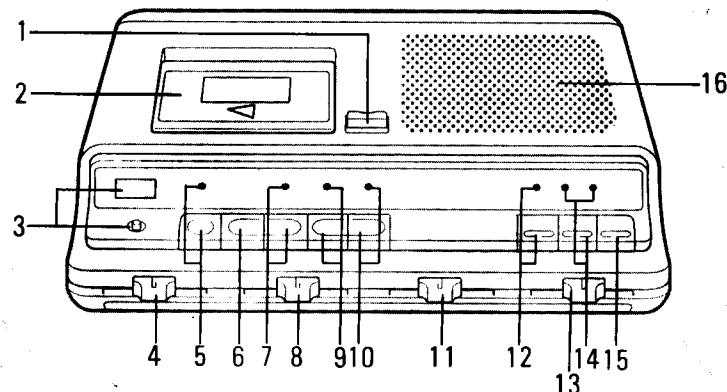

Foot control

- 20. Back switch (BACK)
- 21. Play switch (PLAY)

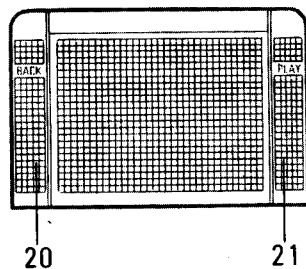

PREPARATIONS

Connections

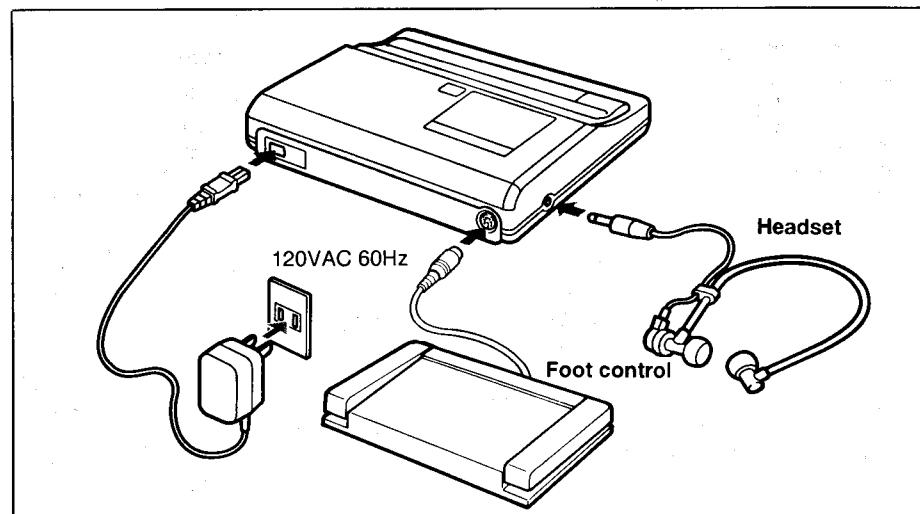

Loading a microcassette

1. Pull the EJECT lever to open the cassette compartment lid.
2. Load a microcassette with the full reel to the right.
3. Close the lid by pressing it.

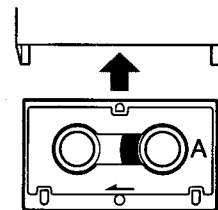

NOTES:

- Be sure to close the lid after loading a microcassette. The unit does not operate unless the lid is closed.
- Do not attempt to operate the EJECT lever while the unit is operating. When unloading a microcassette, first press the STOP button and then pull the EJECT lever to open the lid.

Warning beep tones

The unit emits a warning tone in the following cases:

No cassette:

A tone sounds if there is no cassette in the unit when the unit is in the operating mode.

End of tape:

A tone sounds when the tape reaches the end in all operating modes.

Erase protection:

A tone sounds if you attempt to erase a microcassette whose erasure guard tab has been broken.

TRANSCRIPTION

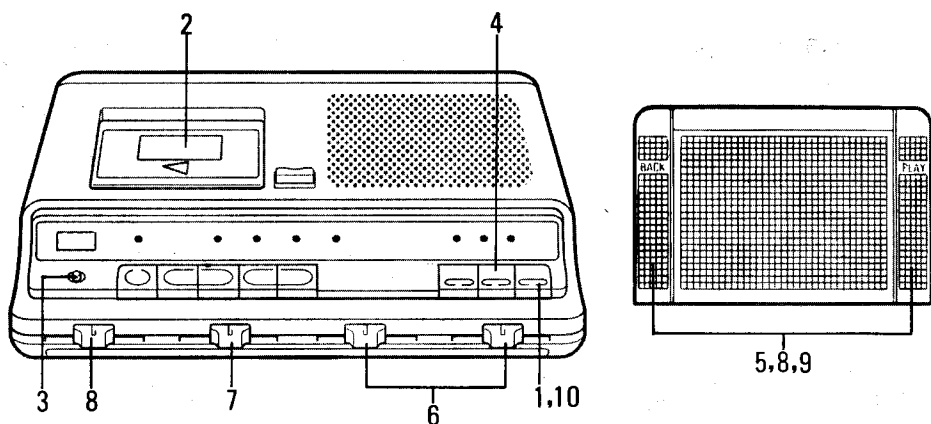

1. Press the POWER button (button DOWN).
2. Load the microcassette to be played.
3. Press the RESET button to set the counter to "000".
 - The tape counter helps you to quickly locate recorded selections for playback.
 - The tape counter will be set to "000" when the tape is ejected.
4. Set the SPEED button to 2.4 or 1.2 to correspond with the recorded tape speed.
5. Press the PLAY switch on the foot control to begin transcribing. Playback will continue while the switch is being pressed.
 - Playback can also be started by pressing the PLAY button on the unit. In this case, the STOP button can be pressed to stop playback.
6. Adjust the VOLUME and TONE controls as desired.
7. Use the SPEED control to adjust the playback speed to your liking.
 - The "0" position on the scale is for normal tape speed.
8. If you wish to review your dictation, release the PLAY switch. The tape automatically backspaces according to the BACKSPACE control setting.
 - Use the BACKSPACE control to adjust the automatic backspace feature for your convenience.
 - For a longer review, press and hold the BACK switch and the tape backspaces continuously until you release the BACK switch.
9. To pause, release the PLAY switch. Continue with this start-stop method until the transcription is completed.
10. To turn the unit off, press the POWER button (button UP).

Index search

1. Press the SEARCH button (button DOWN).
2. Press the REW or FFWD button on the unit.
 - The tape stops briefly and a beep tone sounds when the tape reaches the index mark you have recorded.
 - When using the foot control, press the BACK switch.

NOTE:

The index marks are made on the SANYO TRC-6300 Memo-scriber.

Erasing

After transcription is completed, you can erase the microcassette.

1. While holding down the ERASE button, press the REW button. The ERASE and REW indicators will light.
2. When the tape reaches the end, a beep tone sounds. Press the STOP button to stop erasing.
 - You can also perform "forward erasing" by pressing both the ERASE and FFWD buttons.

Use as a tape player

You can also play a pre-recorded microcassette on the unit. Load a microcassette and press the PLAY button. Use the FFWD or REW button to advance or rewind the tape rapidly.

Safeguards against accidental erasure

To protect side A, break out tab (1). To protect side B, break out tab (2).

- To record or erase a protected cassette, cover the erase guard tab openings with adhesive tape (3).

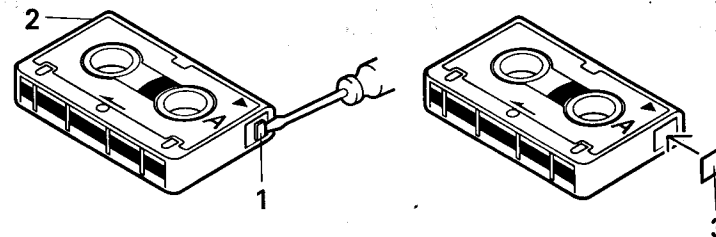

MAINTENANCE

Cleaning the cabinet

Use a clean soft cloth moistened with plain lukewarm water and wrung dry. Never use benzol, benzene or other strong chemical cleaners since these could damage the finish of your unit. It is important that no liquid reaches the inside of the unit.

Cleaning the head

For continued high performance, periodically clean the head, pinch roller and capstan whenever an accumulation of dust and red-brown oxide particles is noticed.

To do this, pull the EJECT lever to open the cassette compartment lid. Remove the microcassette and switch off the power. Carefully rub the head (4), pinch roller (3) and capstan (2) with a cotton swab (1) moistened with isopropyl alcohol or special head-cleaning fluid.

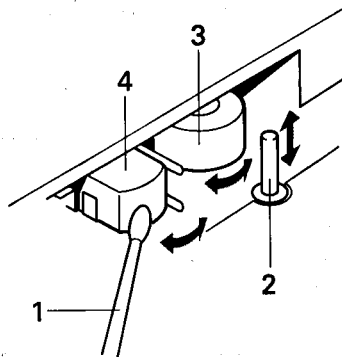

SANYO

21350 Lassen Street
Chatsworth CA 91311
Printed in Hong Kong