



## **PAS Articulating Hedge Clipper Attachment *Operator's Manual***

**MODEL 99944200590**

Serial Number 001001 & Up

**FOR MODELS:**

- SRM-2100SB/2400SB**
- SRM-210SB/211SB**
- SRM-260SB/261SB**
- PAS-2100/2400**
- PAS-210/211**
- PAS-230/231**
- PAS-260/261**
- PAS-2601**



### **WARNING DANGER**

Read rules for safe operation and instructions carefully. ECHO provides an Operator's Manual and a Safety Manual for Pro Attachment Series power source or Split Boom Trimmer. Those manuals and this manual must be read and understood for proper and safe operation, otherwise serious personal injury may result.

## INTRODUCTION

Welcome to the ECHO family. This ECHO product was designed and manufactured to provide long life and on-the-job-dependability. Read and understand this manual included with your attachment. You will find this manual easy to use and full of helpful operations tips and SAFETY messages.

### THE OPERATOR'S MANUAL

Read and understand this manual before operation. Keep it in a safe place for future reference. It contains specifications and information for operation and maintenance specific to the attachment.

### THE SAFETY MANUAL

Explains possible hazards and what measures you should take to insure safe operation.



## TABLE OF CONTENTS

Introduction .....	2	Operation .....	9
- The Operator's Manual .....	2	- Adjusting Cutting Angle .....	9
- The Safety Manual .....	2	Maintenance .....	10
Manual Safety Symbols and Important Information ..	3	- Skill Levels .....	10
Safety .....	3	- Maintenance Intervals .....	10
- Decals .....	3	- Lubrication .....	11
- International Symbols .....	4	- Sharpening Blades .....	13
Safety Instructions .....	4	- Blade Adjustment .....	14
- Personal Condition and Safety Equipment .....	4	Storage .....	14
- Extended Operation/Extreme Conditions .....	5	Servicing Information .....	16
- Equipment .....	5	- Parts .....	16
- Safe Operation .....	6	- Service .....	16
Description .....	7	- ECHO Consumer Product Support .....	16
- Contents .....	7	- Warranty Card .....	16
Specifications .....	8	- Additional or Replacement Manuals .....	16
Assembly .....	8		
- Power Head Shaft/Lower Shaft Assembly .....	8		

Specifications, descriptions and illustrative material in this literature are as accurate as known at the time of publication, but are subject to change without notice. Illustrations may include optional equipment and accessories, and may not include all standard equipment.

## MANUAL SAFETY SYMBOLS AND IMPORTANT INFORMATION

Throughout this manual and on the product itself, you will find safety alerts and helpful, information messages preceded by symbols or key words. The following is an explanation of those symbols and key words and what they mean to you.



This symbol accompanied by the words **WARNING** and **DANGER** calls attention to an act or condition that can lead to serious personal injury to operator and bystanders.



The circle with the slash symbol means whatever is shown within the circle is prohibited.



**IMPORTANT** The enclosed message provides information necessary for the protection of the unit.

**NOTE** This enclosed message provides tips for use, care and maintenance of the unit.

## SAFETY

### DECALS

Locate these safety decals on your unit. The complete unit illustration found in the "DESCRIPTION" section, will help you locate them. Make sure the decals are legible and that you understand and follow the instructions on them. If a decal cannot be read, a new one can be ordered from your ECHO Dealer. See PARTS ORDERING instructions for specific information.

#### Shaft Decal



P/N 890178-54331

#### WARNING DANGER

This unit is not designed to insulate against hazards associated with the contact of wires carrying electrical current. To avoid possible injury/death due to electrical shock or other hazards. **DO NOT** operate unit if any wires (power, telephone, cable, etc.) are closer than 15 feet (4/5 meters) minimum distance, to any part of the unit or operator.



P/N 89016012360

#### WARNING DANGER

This unit can be dangerous if used improperly. • Falling objects and/or blade contact can cause serious injury to operator, helpers and bystanders. • Keep helpers and bystanders at least 50 feet (15m) clear of operating area. • To reduce injury risk, **READ AND UNDERSTAND** the operator's Manual, replacement copies are available through your ECHO dealer. • Wear Protective clothing (head, hearing and eye protection meeting ANSI standards) specified in the Operator's Manual. • **STOP** engine before making repairs or blade adjustments. • **ALWAYS** use adjustment handle when adjusting blade angle. • Keep hand away from blade.



## INTERNATIONAL SYMBOLS

Symbol form/shape	Symbol description/application	Symbol form/shape	Symbol description/application
	Read and understand Operator's Manual.		Fuel and oil mixture
	Wear eyes, ears and head protection		Finger Severing
	Hot Surface		Wear hand protection. Use two handed.
	Safety/Alert		DO NOT smoke near fuel.
	Avoid all power lines. This unit is not insulated against electrical current.		Do not operate closer than 15 M (50 ft.) from electrical hazards.
	Keep bystanders at least 15 meters (50 feet) away.		Plan retreat path from falling objects.

Symbol form/shape	Symbol description/application	Symbol form/shape	Symbol description/application
	DO NOT allow flames or sparks near fuel.		Wear slip resistant foot wear.
	Engine choke control.		Ignition ON/OFF
	Emergency stop		Primer bulb
	Chain lubrication		Carburetor adjustment - High speed mixture
	Carburetor adjustment - Low speed mixture		Carburetor adjustment - Idle speed

## SAFETY INSTRUCTIONS

### PERSONAL CONDITION AND SAFETY EQUIPMENT

#### WARNING DANGER

Hedge Clipper users risk injury to themselves and others if the unit is used improperly or safety precautions are not followed. Proper clothing and safety gear must be worn when operating a hedge clipper.

#### *Physical Condition*

Your judgment and physical dexterity may not be good:

- if you are tired or sick,
- if you are taking medication,
- if you have taken alcohol or drugs.

Operate unit only if you are physically and mentally well.

#### *Eye Protection*

Wear eye protection that meets ANSI Z87.1 or CE requirements whenever you operate the unit.

#### *Hand Protection*

Wear no-slip, heavy duty work gloves to improve your grip on the unit handles. Gloves also reduce the transmission of machine vibration to your hands.

#### *Hearing Protection*

ECHO recommends wearing hearing protection whenever unit is used.

#### *Proper Clothing*

Wear snug fitting, durable clothing;

- Pants should have long legs, shirts with long sleeves.
- DONOTWEARSHORTS,
- DONOTWEARTIES,SCARVES,JEWELRY.

Wear sturdy work shoes with non-skid soles;

- DONOTWEAROPENTOEDSHOES,
- DONOTOPERATEUNITBAREFOOTED.

#### *Hot Humid Weather*

Heavy protective clothing can increase operator fatigue which may lead to heat stroke. Schedule heavy work for early morning or late afternoon hours when temperatures are cooler.

## EXTENDED OPERATION/EXTREME CONDITIONS

### *Vibration and Cold*

It is believed that a condition called Raynaud's Phenomenon, which affects the fingers of certain individuals may be brought about by exposure to vibration and cold. Exposure to vibration and cold may cause tingling and burning sensations followed by loss of color and numbness in the fingers. The following precautions are strongly recommended because the minimum exposure which might trigger the ailment is unknown.

- Keep your body warm, especially the head, neck, feet, ankles, hands and wrists.
- Maintain good blood circulation by performing vigorous arm exercises during frequent work breaks and also by not smoking.
- Limit the hours of operation. Try to fill each day with jobs where operating the trimmer or other hand-held power equipment is not required.
- If you experience discomfort, redness and swelling of the fingers followed by whitening and loss of feeling, consult your physician before further exposing yourself to cold and vibration.

### *Repetitive Stress Injuries*

It is believed that overusing the muscles and tendons of the fingers, hands, arms and shoulders may cause soreness, swelling, numbness, weakness and extreme pain in those areas. Certain repetitive hand activities may put you at a high risk for developing a Repetitive Stress Injury (RSI). An extreme RSI condition is Carpal Tunnel Syndrome (CTS), which could occur when your wrist swells and squeezes a vital nerve that runs through the area. Some believe that prolonged exposure to vibration may contribute to CTS. CTS can cause severe pain for months or even years.

To reduce the risk of RSI/CTS, do the following:

- Avoid using your wrist in a bent, extended or twisted position. Instead try to maintain a straight wrist position. Also, when grasping, use your whole hand, not just the thumb and index finger.
- Take periodic breaks to minimize repetition and rest your hands.
- Reduce the speed and force with which you do the repetitive movement.
- Do exercises to strengthen the hand and arm muscles.
- Immediately stop using all power equipment and consult a doctor if you feel tingling, numbness or pain in the fingers, hands, wrists or arms. The sooner RSI/CTS is diagnosed, the more likely permanent nerve and muscle damage can be prevented.

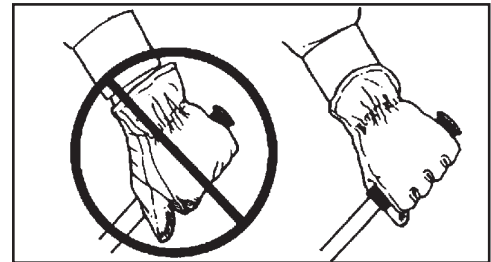

## EQUIPMENT

### WARNING DANGER

Use only ECHO approved attachments. Serious injury may result from the use of a non approved attachment combination. Read and comply with all safety instructions listed in this manual and safety manual.

- Check unit for loose/missing nuts, bolts and screws. Tighten and/or replace as needed.
- Inspect fuel lines, tank and area around carburetor for fuel leaks. DO NOT operate unit if leaks are found.
- Never adjust blades when the engine is operating.
- Inspect hand guard for damage. Replace if damaged or missing.
- Check that the blade assembly is firmly attached and in safe operating condition. Dull, loose or damaged blades should not be used.
- Keep exhaust area clear of flammable debris. Avoid contact during and immediately after operation.

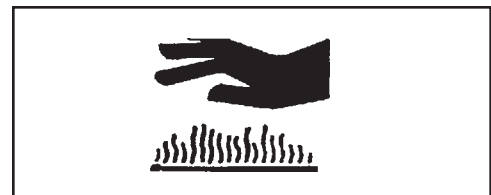

### NOTE

ECHO, INC. will not be responsible for the failure of cutting devices or accessories which have not been tested and approved by ECHO for use with this unit.

## SAFE OPERATION

### WARNING DANGER

Do not operate this product indoors or in inadequately ventilated areas. Engine exhaust contains poisonous emissions and can cause serious injury or death.

#### Read the Manuals

- Provide all users of this equipment with the Operator's Manual and Safety Manual for instructions on Safe Operation.

#### Clear the Work Area

- Spectators and fellow workers must be warned, and children and animals prevented from coming nearer than 15 m (50 ft.) while the unit is in use.

#### Keep a Firm Grip

- Hold the front and rear handles with both hands, with thumbs and fingers tightly encircling the handles.

#### Keep a Solid Stance

- Maintain footing and balance at all times. Do not stand on slippery, uneven or unstable surfaces. Do not work in odd positions or on ladders. Do not over reach.

#### Cutting Angle Adjustments

- Only adjust cutting blade angle with unit flat on the ground, with the engine stop switch in the "STOP" position. Never adjust cutting angle with unit standing upright.

#### Avoid Contact With Gear Box Assembly During Use

- Gear box assembly becomes hot during use. Avoid contact with gear box assembly when using unit or making cutting angle adjustments.

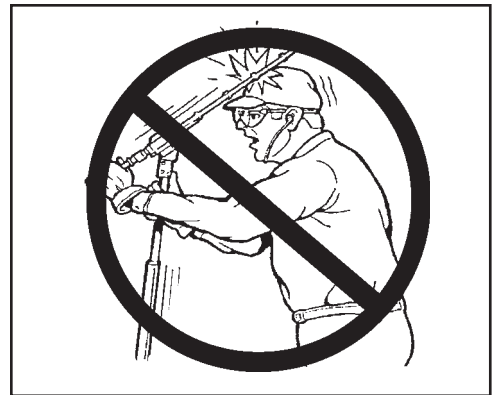
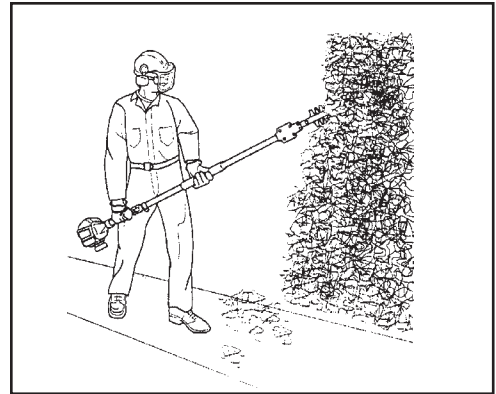

## DESCRIPTION

The ECHO product you have purchased has been factory pre-assembled for your convenience.

After opening the carton, check for damage. Immediately notify your retailer or ECHO Dealer of damaged or missing parts. Use the contents list to check for missing parts.

## CONTENTS LIST

- \_\_\_\_\_ 1 - Articulating Hedge Clipper Attachment
- \_\_\_\_\_ 1 - Operator's Manual
- \_\_\_\_\_ 1 - Hedge Clipper Safety Manual
- \_\_\_\_\_ 1 - Warranty Registration Card
- \_\_\_\_\_ 1 - 8 x 10 mm Wrench
- \_\_\_\_\_ 1 - 4 mm Hex Wrench
- \_\_\_\_\_ 1 - Blade Cover

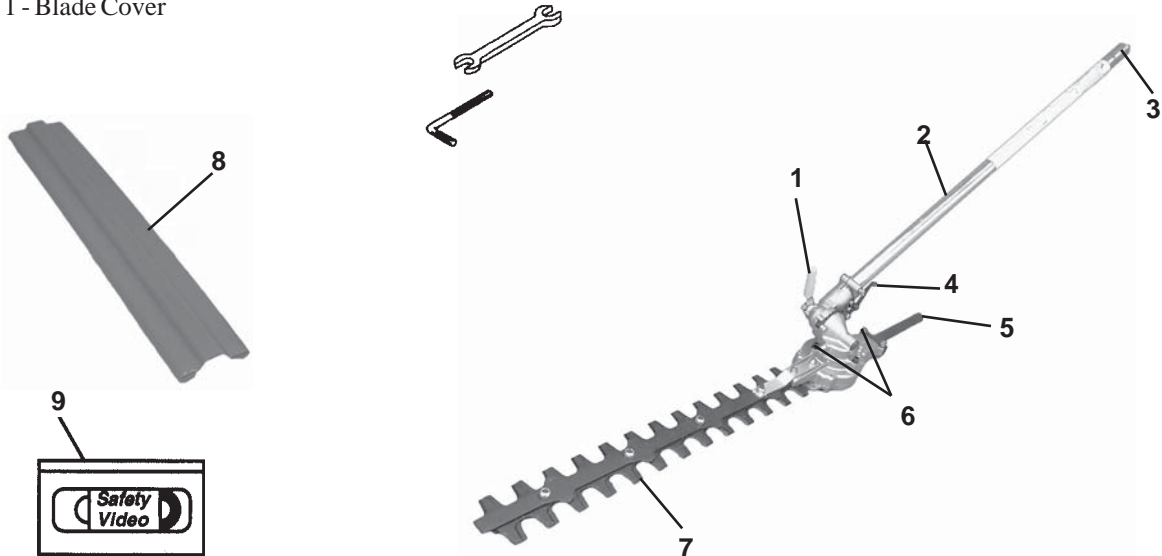

1. **GEAR TENSION RELEASE LEVER** - Moving lever up releases tension on gears to permit adjustment of blade cutting angle when indexing lever is pressed. The gear tension release lever **MUST** be placed in the down position to remove internal gear play before operating the hedge clipper. The gear tension lever **DOES NOT** secure gear box angle setting.
2. **LOWER DRIVE SHAFT ASSEMBLY** - Includes the Gear Housing assembly, Flexible Drive Cable, Blade and Safety Decals.
3. **FLEXIBLE DRIVE CABLE** - Cable end fits into upper drive shaft coupler. Lubricate drive cable every 25 hours with ECHO<sup>®</sup> LUBE<sup>™</sup> grease.
4. **BLADE ANGLE INDEXING LEVER** - Spring loaded lever that engages with a notch every 15 degrees to secure cutting angle adjustment. Press lever to disengage from notch, release after new position is selected.
5. **GEAR HOUSING HANDLE** - Provides secure handgrip for adjusting cutting blade angle.
6. **GREASE FITTINGS** - Grease gear case every 15-20 hours of operation or on a weekly schedule.
7. **CUTTING BLADES** - Double reciprocating blades mounted to a blade support bar. Double sided blades, are capable of cutting on either side of the blade.
8. **BLADE COVER** - Used to cover blades during transport and storage. Remove blade cover before operating unit.
9. **HEDGE CLIPPERS SAFETY VIDEO** - (Not included with unit) P/N 99922202800 English version and P/N 99922203513 Spanish version are available at a cost of \$5.00 from ECHO, INC. or any authorized ECHO dealer. The video overviews safety precautions and proper operating techniques and is supplemental to the Safety Manual. Read and understand the Safety Manual for complete information on safe operation.

## SPECIFICATIONS

### *PAS Articulating Hedge Clipper Attachment*

Shaft Length -----	1282.7 mm (50.5 in.)
Attachment Width -----	114.30 mm (4.50 in.)
Height -----	92.1 mm (3.63 in.)
Weight -----	2.73 kg. (6.02 lb.)
Gear Case Ratio -----	3.5 : 1
Cutter -----	Double Reciprocating Blade - Double Edge
Effective Length -----	411 mm (16.2 in.)
Pitch -----	35 mm (1.4 in.)
Maximum Diameter Cut	
Soft Material -----	25.4 mm (1 in.)
Woody Material -----	13 mm (1/2 in.)

## ASSEMBLY

### POWER HEAD SHAFT/LOWER SHAFT ASSEMBLY

*Tools Required:* None

*Parts Required:* PAS or SRM-SB Power Head w/Shaft & Coupling.

1. Set Power Head/Shaft Assembly on a level surface.
2. Pull locator pin (A) out, and turn counter-clockwise 1/4 turn to lock-out position.
3. Carefully fit attachment drive shaft assembly into coupler (B) to decal assembly line (C), making sure that the inner lower drive shaft engages into the square upper drive shaft socket.

#### NOTE

Earlier model Power Heads may have shorter couplings. Short couplings fit flush to decal point (E). New couplings are 4-3/4 in. long, and fit flush to line (C).

4. Select desired blade position by aligning one of the holes (F) in lower shaft with locator pin position.
5. Rotate locator pin (A) 1/4 turn clockwise to engage lower shaft hole. Insure locator pin is fully engaged by twisting lower drive shaft. Locator pin should snap flush in coupler. Full engagement will prevent further shaft rotation.
6. Secure lower shaft assembly to coupler by tightening clamping knob (D).

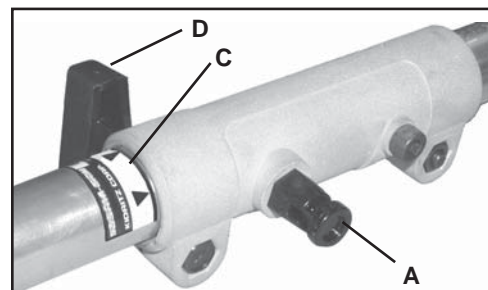
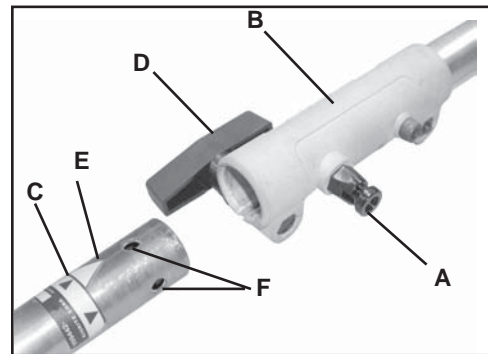



## OPERATION

### **WARNING** **DANGER**

All over head electrical conductors and communications wires can have electricity flow with high voltages. Never touch wires directly or indirectly when pruning, otherwise serious injury or death may result.

### ADJUSTING CUTTING ANGLE

1. Place unit on a flat, clear area. Make sure stop switch is in the “STOP” position.
2. Move gear tension release lever (A) to “up” position.
3. Grip hedge clipper shaft at gear box.
4. Grip rear handle of cutter assembly, and hold securely.
5. Depress blade indexing lever (B) to release cutter assembly.
6. Adjust cutter assembly angle to desired position, and release indexing lever into notch.
7. Move gear tension release lever (A) to full “down” position.

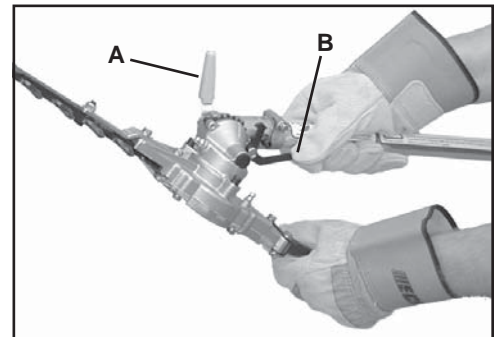

### **IMPORTANT**

DO NOT tighten gear tension release lever nut (C) to secure angle setting of gear box. Damage to gears will result. Adjust nut **ONLY** if gear tension release lever is too loose, or too tight. Tighten nut for snug 90° movement.

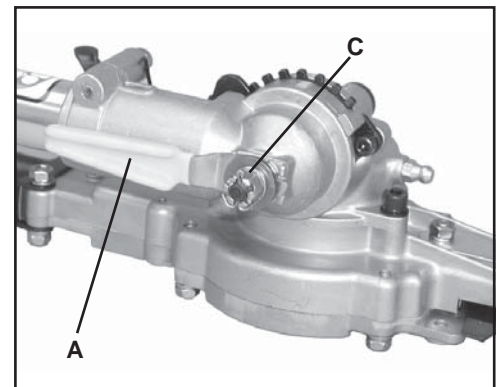

### **WARNING** **DANGER**

Gear Case Assembly becomes **HOT** during use. Always grip assembly at black rear handle when making cutting angle adjustments, otherwise serious injury may result.

### **WARNING** **DANGER**

DO NOT stand hedge clipper on end when adjusting cutting angle, otherwise serious injury may result.

## MAINTENANCE

Your ECHO trimmer is designed to provide many hours of trouble free service. Regular scheduled maintenance will help your trimmer achieve that goal. If you are unsure or are not equipped with the necessary tools, you may want to take your unit to an ECHO Service Dealer for maintenance. To help you decide whether you want to DO-IT-YOURSELF or have the ECHO Dealer do it, each maintenance task has been graded. If the task is not listed see your ECHO dealer for repairs.

## SKILL LEVEL

- Level 1** = Easy to do. Most required tools come with unit.
- Level 2** = Moderate difficulty. Some specialized tools may be required.
- Level 3** = Experience required. Specialized tools are required. ECHO recommends that the unit be returned to your ECHO dealer for service.

## MAINTENANCE INTERVALS

<u>Component/System</u>	<u>Maintenance Procedure</u>	<u>Skill Level</u>	<u>Frequency</u>
Cutting Blades	Oil/Clean	1	Before each use
Drive Shaft	Grease	1	Every 50 hours of use
Gear Housing	Grease	1	Every 15-25 hours of use
Screws/Nuts/Bolts	Inspect/Tighten/Replace	1	Before each use

## LUBRICATION

### *Blades*

#### Level 1

*Tools Required:* Clean rag, brush, oil can

*Parts Required:* 20W Engine Oil (lubrication), 50-50 mixture of kerosene and 20W oil (cleaning).

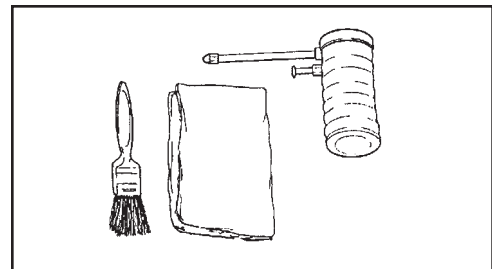

### **WARNING** **DANGER**

Blades are very sharp. Wear gloves to protect hands, otherwise serious personal injury may result.

1. Brush loose debris from blade and coat both sides of blade with the 50-50 cleaning mixture.
2. Allow cleaning mixture to soften the remaining gummy residue then wipe it from the blade.
3. Apply clean oil to the entire length of the blade. Be certain the blade bolts are lubricated.
4. Wipe excess oil from the blade before putting the unit back in service.

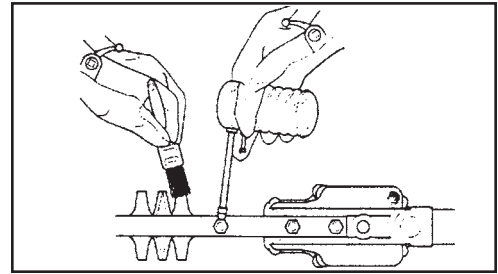

## Gear Housing

### Level 1.

*Tools required:* Grease Gun, Rag.

*Parts required:* ECHO® LUBE™ 14 oz. Cartridge P/N 91015 Grease or Lithium-based Grease.

1. Clean dirt from grease fittings (A).
2. Carefully pump grease in each fitting. **DO NOT** force grease. Too much pressure will force grease past seals and cause damage. Apply 1-2 pumps of grease every 15-25 hours of operation.

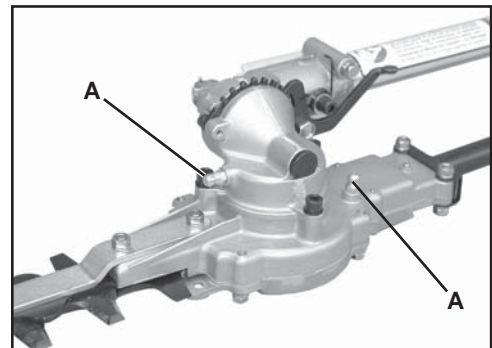
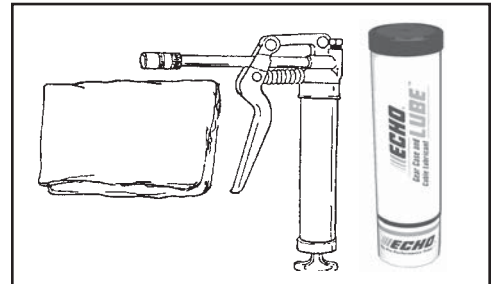

## Drive Shaft (Lower)

### Level 1.

**Tools required:** 4 mm hex wrench, 8mm Open End Wrench, Clean Rag, Small Brush.

**Parts required:** ECHO<sup>®</sup> LUBE™ 14 oz. cartridge P/N91015 or Lithium-based Grease.

#### IMPORTANT

Lower and upper drive shaft must be lubricated with ECHO<sup>®</sup> LUBE™ grease every 50 hours of operation, otherwise drive shaft assembly overheating and failure can result.

1. Carefully remove locating screw and washers (A) to avoid loss of blade indexing lever spring (B), and loosen clamping screw (C). Remove the flex drive shaft assembly from the gear housing.
2. Pull the drive shaft (D) from the drive shaft assembly, and wipe clean. Re-coat with a thin coating [1/2 oz. (15 ml)] of grease.
3. Slide the flex shaft back into the drive shaft assembly, being careful not to get dirt on the flex shaft.

#### NOTE

Install drive shaft in gear case to provide desired blade adjustment direction.

4. Align the locating screw hole in gear case with the locating hole in drive shaft assembly, and install and tighten locating screw with washers (A), and tighten clamping screw (C).

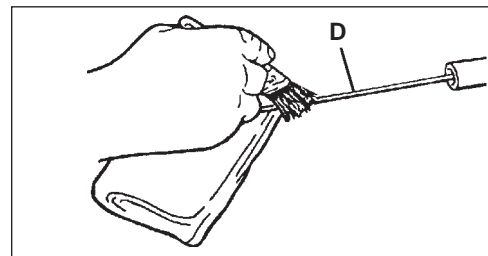
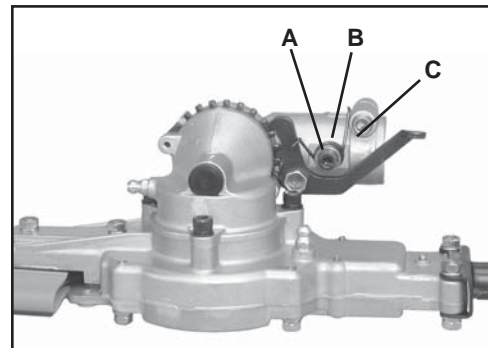
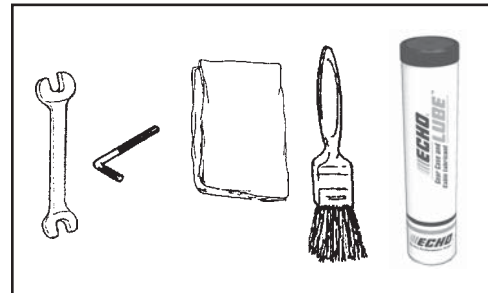

## SHARPENING BLADES

### Level 3.

*Tools required:* Flat file, round file, screwdriver

*Parts required:* None

### WARNING DANGER

Hedge Clipper Blades are very sharp. Wear gloves to protect hands.

1. Disconnect spark plug wire from spark plug.
2. Slide blades to allow file clearance using slots (A) on bottom of blades. Do not pry against cutting edges.
3. Follow the original shape, and file each cutting edge carefully to avoid damage to adjacent teeth. Maintain 6 mm (.25 in.) radius at base of each tooth.

### IMPORTANT

If a power grinder is used, **DO NOT** allow blade to over heat.

4. Lubricate blades. See "Lubrication" on page 11.
5. Connect spark plug wire.

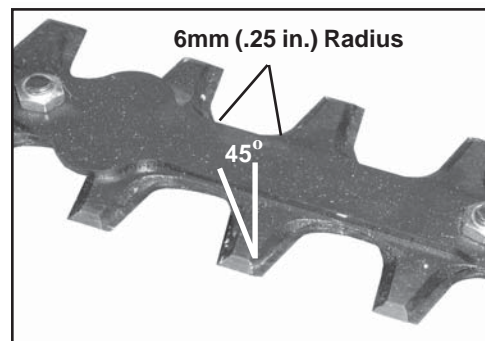
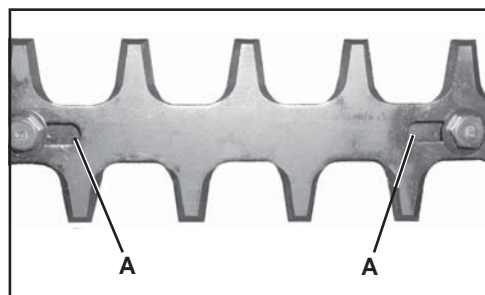
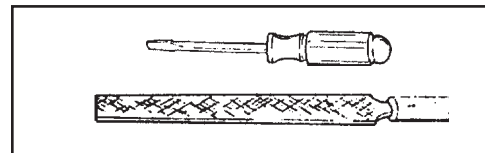

## BLADE ADJUSTMENT

### Level 2.

*Tools required:* (2) 10 mm wrenches

*Parts required:* None

#### IMPORTANT

Blades should only be removed and reinstalled by an Authorized ECHO Servicing Dealer, otherwise premature wear or internal damage may occur.

1. Tighten blade bolts until snug, then loosen blade bolts 1/2 turn.
2. Hold blade bolts from turning using 10 mm wrench, and tighten blade lock nuts with other 10 mm wrench.

#### NOTE

Locking ability of Hedge Clipper blade lock nuts will diminish each time they are removed. Replace if turning resistance is not felt when installing locknuts.

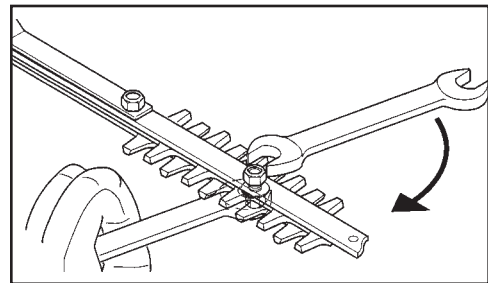
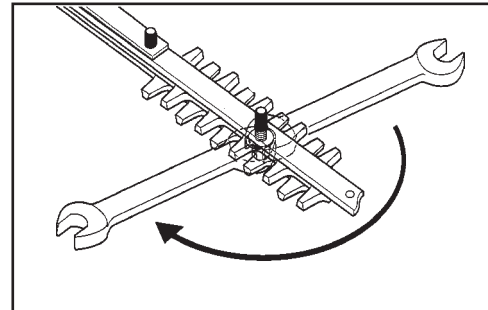
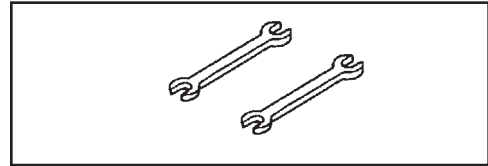

## STORAGE

#### IMPORTANT

Always store and transport hedge clippers in a stable, horizontal position. Support gear case and cutting blades to prevent excessive flexing which may cause damage to the cutting attachment. Always install blade cover when transporting or storing unit.

1. Clean and lubricate cutting blades and gear case.
2. Sharpen cutting blades as required.
3. Apply a light coating of clean 20W engine oil along entire length of blades and on blade bolts.
4. Install blade cover onto hedge clipper cutting blades.
5. Store hedge clipper attachment in a dry, dust free place in a horizontal position, out of the reach of children.

**NOTES**

## SERVICING INFORMATION

### PARTS

Genuine ECHO Parts and ECHOREPOWER™ Parts and Assemblies for your ECHO products are available only from an Authorized ECHO Dealer. When you do need to buy parts **always** have the Model Number and Serial Number of the unit with you. You can find these numbers on the engine housing. For future reference, write them in the space provided below.

Model No. \_\_\_\_\_ SN. \_\_\_\_\_

### SERVICE

Service of this product during the warranty period must be performed by an Authorized ECHO Service Dealer. For the name and address of the Authorized ECHO Service Dealer nearest you, ask your retailer or call: 1-800-432-ECHO (3246). Dealer information is also available on our Web Site. When presenting your unit for Warranty service/repairs, proof of purchase is required.

### ECHO CONSUMER PRODUCT SUPPORT

If you require assistance or have questions concerning the application, operation or maintenance of this product you may call the ECHO Consumer Product Support Department at 1-800-673-1558 from 8:30 am to 4:30 pm (Central Standard Time) Monday through Friday. Before calling, please know the model and serial number of your unit to help your Consumer Product Support Representative.

### WARRANTY REGISTRATION

You may register your Echo equipment using the warranty registration card or register on-line at [www.echo-usa.com](http://www.echo-usa.com). Registering provides a direct link between you and ECHO if we find it necessary to contact you.

### ADDITIONAL OR REPLACEMENT MANUALS

**Safety Manuals** in English/Spanish or English/French are available, free of charge, from your ECHO dealer or at [www.echo-usa.com](http://www.echo-usa.com).

**Operator's and Parts Manuals** are available by:

- Downloading free from [www.echo-usa.com](http://www.echo-usa.com)
- Purchasing from your Echo Dealer.
- Manuals are available by sending a written request stating the model number and serial number of your Echo unit, part number of the manual, your name and address, and mail to the address below.

**Safety Videos** are available from your Echo dealer. A \$5.00 shipping charge will be required for each video.

### *Available Parts Catalog*

PAS Articulating Hedge Clipper Attachment Model 99944200590  
Part Number 99922203332

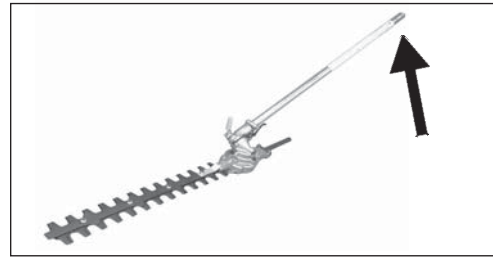

### DEALER?

Call  
**1-800-432-ECHO**  
or  
**[www.echo-usa.com](http://www.echo-usa.com)**

### CONSUMER PRODUCT SUPPORT

**1-800-673-1558**  
**8:30 - 4:30 Mon - Fri C.S.T.**



**ECHO**  
ECHO, INCORPORATED  
400 OAKWOOD ROAD  
LAKE ZURICH, IL 60047  
[www.echo-usa.com](http://www.echo-usa.com)