

Design LED 12 Brick II

Elation Professional™
6122 S. Eastern Ave.
Los Angeles, CA. 90040
www.elationlighting.com

TABLE OF CONTENTS

CONTENTS

1. General Information.....	2
a. Introduction.....	2
b. Unpacking.....	2
c. Customer Support.....	2
d. Warranty Registration.....	3
2. Safety Instructions.....	4
3. Features.....	6
4. General Guidelines.....	7
5. Fixture Overview.....	8
6. Mounting and Installation.....	10
7. Understanding DMX.....	13
a. DMX Connections.....	16
b. DMX Terminator.....	16
c. 3-Pin to 5-Pin Conversion.....	16
d. Understanding DMX Addressing.....	16
8. Operation Modes.....	17
a. DMX Mode Selection.....	19
b. Manual Settings.....	19
9. DMX Traits.....	20
10. Cleaning and Maintenance.....	24
11. Warranty.....	25
12. Photometric Data.....	27
13. Dimensional Drawings.....	28
14. Change lens to get different beam angles.....	28
15. Circuit Schematic.....	29
16. Technical Specifications.....	30

1. GENERAL INFORMATION

INTRODUCTION: Congratulations, you have just purchased one of the most innovative and reliable LED fixtures on the market today! The Design LED 12 Brick II ™, has been designed to perform reliably for years when the guidelines in this booklet are followed. Please read and understand the instructions in this manual carefully and thoroughly before attempting to operate this unit. These instructions contain important information regarding safety during use and maintenance.

UNPACKING: Thank you for purchasing the Design LED 12 Brick II ™ by Elation Professional®. Every Design LED 12 Brick II ™ has been thoroughly tested and has been shipped in perfect operating condition. Carefully check the shipping carton for damage that may have occurred during shipping. If the carton appears to be damaged, carefully inspect your fixture for damage and be sure all accessories necessary to operate the fixture have arrived intact. In the event damage has been found or parts are missing, please contact our customer support team for further instructions. Please do not return this unit to your dealer without first contacting customer support at the number listed below.

Inside the box you should find: the fixture, a DMX XLR cable, an IEC power cable, an IEC “jumper” power cable, a safety cable, and this manual. Please contact customer support at the number listed below if any of the above items are missing.

CUSTOMER SUPPORT: Elation Professional® provides a customer support line, to provide set up help and to answer any question should you encounter problems during your set up or initial operation. You may also visit us on the web at www.elationlighting.com for any comments or suggestions. For service related issue please contact Elation Professional®. Service Hours are Monday through Friday 9:00 a.m. to 5:00 p.m. Pacific Standard Time.

Voice: (323) 582-3322

Fax: (323) 582-3108

E-mail: support@elationlighting.com

Forum: www.ElationLighting.com/forum

Warning! To prevent or reduce the risk of electrical shock or fire, do not expose this unit to

rain or moisture.

Caution! There are no user serviceable parts inside this unit. Do not attempt any repairs yourself. Doing so will void your manufactures warranty.

Please do not discard the shipping carton in the trash. Please recycle whenever possible.

WARRANTY REGISTRATION: The Design LED 12 Brick II ™ carries a two year (730 days) limited warranty. Please fill out the enclosed warranty card to validate your purchase. All returned service items whether under warranty or not, must be freight pre-paid and accompany a return authorization (R.A.) number. The R.A. number must be clearly written on the outside of the return package. A brief description of the problem as well as the R.A. number must also be written down on a piece of paper and included in the shipping container. If the unit is under warranty, you must provide a copy of your proof of purchase invoice. Items returned without a R.A. number clearly marked on the outside of the package will be refused and returned at customer's expense. You may obtain a R.A. number by contacting customer support at (323) 582-3322.

2. SAFETY INSTRUCTIONS



To guarantee proper and consistent operation, it is important to follow the guidelines in this manual. Elation Professional will not accept responsibility for damages resulting from the misuse of this fixture due to the disregard of the information printed in this manual.

1. Always be sure that the fan and the air inlets remain clean and are never blocked. Allow about 6" (15cm) between this fixture and other devices or a wall to allow for proper cooling.
2. Never touch the fixture during normal operation.
3. Never look directly into the lamp beam. You risk injury to your retina, which may induce blindness.
4. For safe operation, follow the Installation guide described in chapter two of this manual. Operating the Design LED 12 Brick II ™ without suited safety aids such as safety cables or clamps can increase the risk of damage and/or personal injury.
5. Installation should only be performed by qualified and certified personal.
6. When mounting this fixture, use only the original rigging points included with this fixture. Any structural modification will void the original manufactures warranty and may increase the risk of damage and/or personal injury.
7. To reduce the risk of fire or shock, do not expose this fixture to rain or moisture.
8. Do not attempt to operate this fixture if the power cord has become damaged or frayed.
9. **Never open this fixture while in use.**
10. This device falls under protection-class I. Therefore it is essential that the device be grounded properly.
11. All electrical connections must performed by qualified personal.
12. Be sure the available voltage matches the voltage requirements of the unit. Be

sure the power cord is never crimped or damaged. If the power cord is damaged, replace it immediately with a new one of similar power rating.

13. Always disconnect from main power before performing any type of service or any cleaning procedure.
14. Only handle the power cord by the plug. Never pull out the plug by tugging the wire portion of the cord.
15. ***Please be aware that damages caused by modifications to the device are not subject to warranty.***

Important Notice: Damages resulting from the disregard of safety and general user instructions found in this user manual are not subject to any warranty claims.



CAUTION!

Never touch the device during operation!
The housing may heat up



CAUTION!

Never look directly into the light source,
as sensitive persons may suffer an epileptic shock.

3. FEATURES

- Low power consumption
- Minimal heat emission
- Maintenance free operation
- Equipped with 12 one-watt LEDs: (4 red, 4 green, 4 blue)
- High power LEDs manufactured by Lumileds, USA
- 100,000 hours **rated** LED life
- Seamless RGB color changing
- USITT DMX-512 compliant
- 5-pin and 3-pin Male and Female XLR Data Connectors
- Preprogrammed colored macros
- Strobe-effect with a maximum flash rate of 18fps
- DMX-controlled operation or stand-alone operation with Master/Slave-function
- 8 built-in programs accessed via DMX-controller or manually
- Sound-controlled via built-in microphone
- Individual control over each LED
- Electronic/Switching power supply (100v~240V 50/60Hz)
- Three DMX Modes:
 - 15 DMX-channels
 - 12 DMX-channels
 - 4 DMX-channels
 - 3 DMX-channels
- Flicker-free operation for television and film
- Compact design: fits in 12" box truss
- Brilliant light output
- Linkable power supply (in and out power connectors) up to 8 units.

4. GENERAL GUIDELINES

This fixture is a professional lighting effect designed for use on stage, in nightclubs, in theatres, and other types of architectural installations. Do not attempt operation or installation without a proper knowledge on how to do so.

This fixture was designed for indoor use only; use of this fixture outside will void the manufacture's warranty.

Consistent operational breaks will ensure that the fixture will function properly for many years to come.

Do not shake the fixture around. Avoid brute force when installing or operating the fixture.

While choosing an installation location, please be sure that the fixture will not be exposed to extreme heat, moisture, or dust. The minimum distance between the fixture and a wall or flat surface should be at least .5 meter (about 1.5ft).

Always install the fixture with an appropriately rated safety cable. When installing the fixture in a suspended environment always be sure to use mounting hardware no less than M10 x 25 mm, also be sure the hardware is only inserted in the yoke's mounting holes.

Do not attempt to operate this fixture until you have familiarized yourself with all of its functions.

Do not permit operation by persons not qualified for operating this type of theatrical fixture. Most damages are the result of improper operation.

Please use the original packaging to transport the fixture in for service.

For your own safety, please read this user manual carefully before installing the device.

5. FIXTURE OVERVIEW

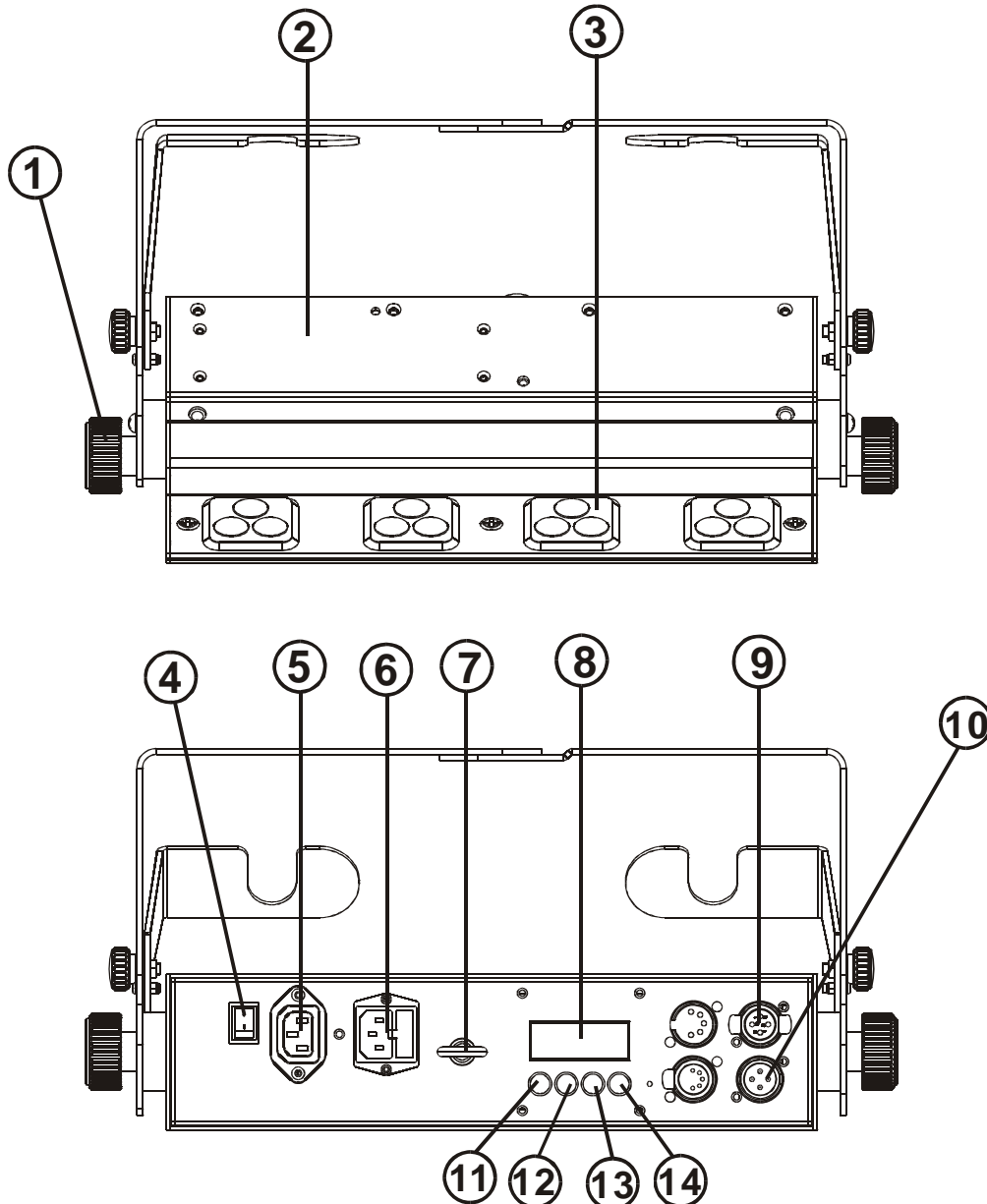

1. **Bracket Locking Knob** – This knob is used to secure the bracket in place after angle adjustments have been made.
2. **Diffusing Lens** – This lens is used to both protect the LEDs as well as diffuse the light output.
3. **LED Assembly** – RGB LED assembly 3x1watt LEDs

4. **On/Off Power Switch** – Controls main power to the unit.
5. **Power Output Jack** – Use this jack to jump power to another Design LED 12 Brick II™
6. **Power Input/Fuse Holder Assembly** – This assembly holds the safety fuse as well as provides a female IEC connector for a power cord. Always replace the fuse with an exact match unless otherwise specified by an authorized Elation Service Technician. Using a fuse other than that specified could seriously damage the unit and will void your manufactures warranty.
7. **Eye-Bolt** - Use this bold as a safety-cable rigging point. Always secure any installation with a properly rated safety-cable.
8. **LED MENU DISPLAY** – Four segment LED menu display, details all menu functions
9. **DMX In Jack** – This jack accepts an incoming DMX signal via a male, 3-pin or a 5-pin XLR jack.
10. **DMX Out Jack** - This jack is used to send an incoming DMX signal to the next fixture in the DMX chain via a female, 5-pin XLR jack.
11. **ESC BUTTON** – This button is used to access and exit the fixture’s on-board menu system.
12. **UP BUTTON** – This button is used to scroll forward when navigating through the fixture’s menu system.
13. **DOWN BUTTON** – This button is used to scroll backwards when navigating through the fixture’s menu system.

14. ENTER BUTTON – This button is used to select and confirm a menu function.

6. MOUNTING AND INSTALLATION

Yoke Assembly – Single Unit Operation (DLED 12 Brick shown for illustration purposes only). The device can be placed directly on the stage floor or rigged in any orientation on a truss without altering its operation characteristics. When connecting the hanging yoke to the fixture, refer to the illustration below.

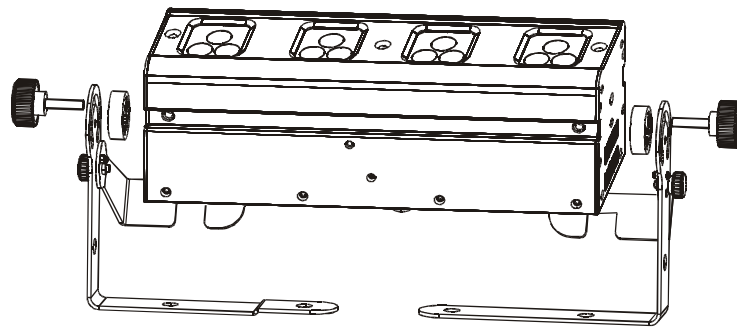

Cautions:

For added protection mount the fixtures in areas outside walking paths, seating areas, and away from areas where the fixture might be reached by unauthorized personnel.

Before mounting the fixture to any surface, make sure that the installation area can hold a minimum point load of 10 times the device's weight.

Fixture installation must always be secured with a secondary safety attachment, such as an appropriate safety cable.

To avoid injury, never stand directly below the device when mounting, removing, or servicing the fixture.



Refer to regulations BGV C1 (formerly VBG 70) and DIN VDE0711-217 for proper installation in Europe. To ensure proper installation, only qualified staff should attempt installation.

Mounting points

Overhead mounting requires extensive experience, including amongst others calculating working load limits, a fine knowledge of the installation material being used, and periodic safety inspection of all installation material and the fixture. If you lack these qualifications, do not attempt the installation yourself. Improper installation can result in bodily injury.

Be sure to complete all rigging and installation procedures before connecting the main power cord to the appropriate wall outlet.

Mounting

The Design LED 12 Brick II ™ is fully operational in three different mounting positions, hanging upside-down from a ceiling, side mounted, or set on a flat level surface. Be sure this fixture is kept at least 0.5m away from any flammable materials (decoration etc.). When clamp mounting; always use and install the supplied safety cable as an added safety measure to prevent accidental damage in the event of a clamp failure. ***See the image below.***

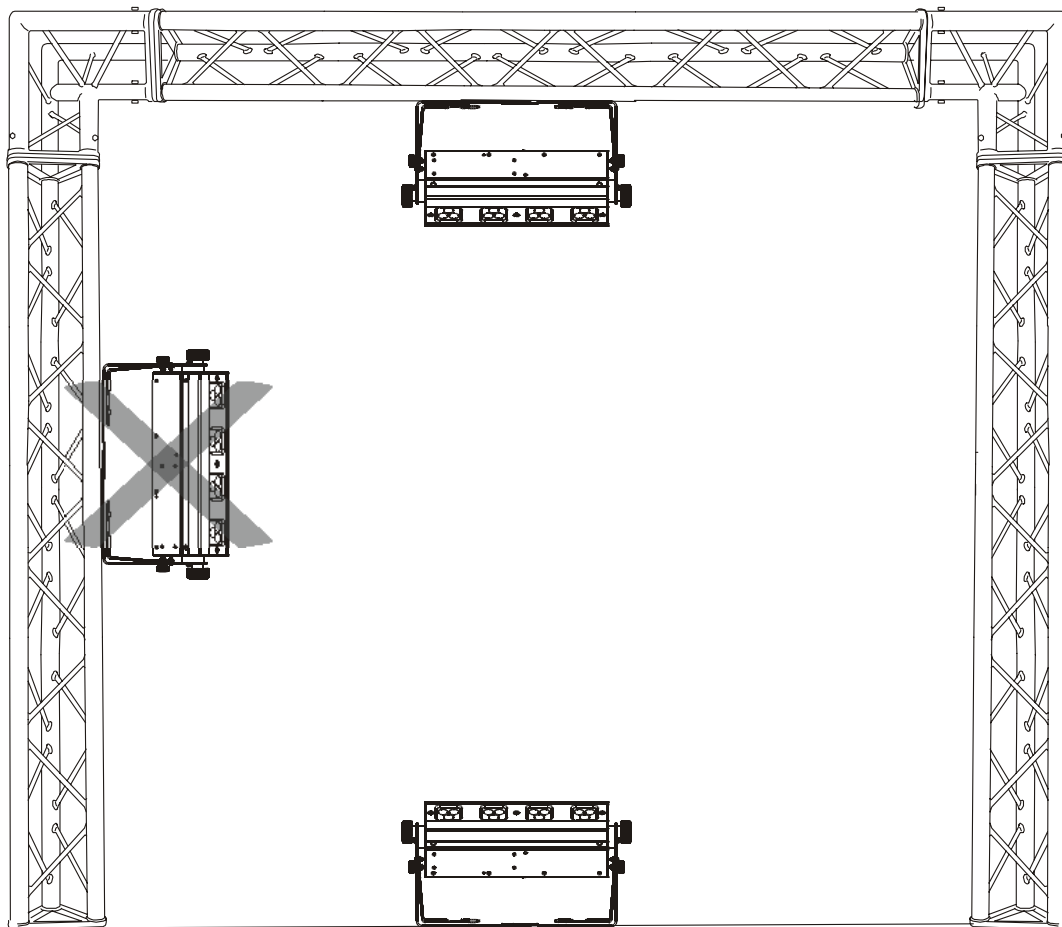
**CAUTION!**

Be sure all electrical connections are performed by a qualified electrician before attempting any operation.

Clamp Mounting

The Design LED 12 Brick II ™ provides a unique mounting bracket assembly that allows the unit to stand on flat surface, hang on truss via a clamp, or be used in cluster allow multiple units to rigged together (see the illustration below). Regardless of the mounting option you choose please refer to the safety guidelines in this manual to avoid damage to the unit and/or injury to persons.

When mounting this fixture to truss be sure to secure an appropriately rated clamp to the hanging yoke using a M10 screw fitted through the center hole of the hanging yoke. As an added safety measure be sure to attach at least one properly rated safety cable to the fixture. See illustration below.

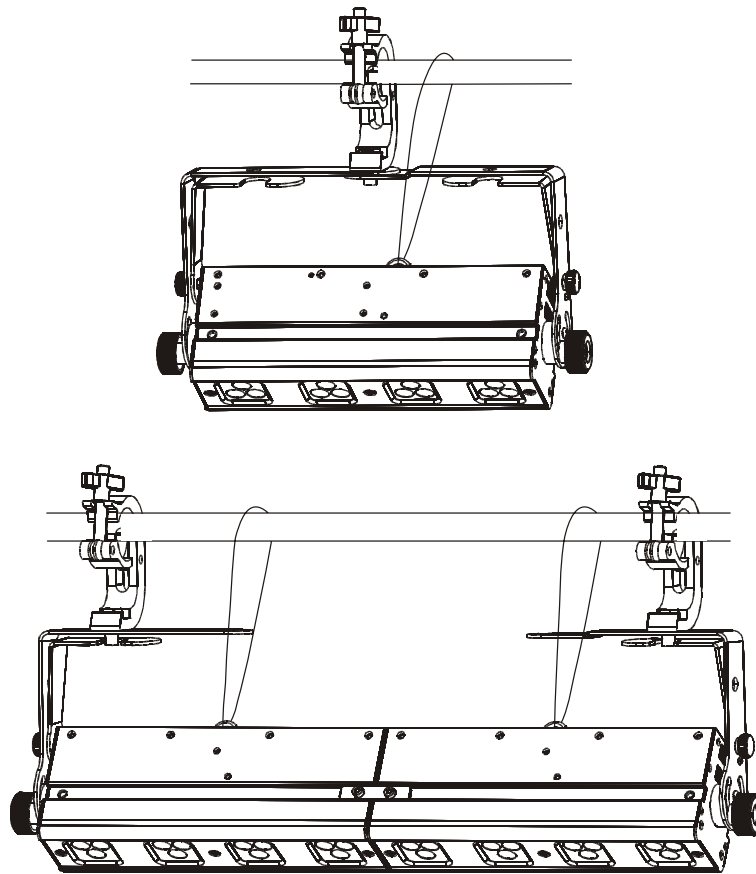

Securing the Design LED 12 Brick II ™



Always secure your fixture with a safety cable when suspending the unit from truss or other means. The fixture provides a built-in rigging point for a safety cable as illustrated above. Be sure to only use the designated rigging point for a safety cable. Never secure a safety cable to the hanging bracket.

7. UNDERSTANDING DMX

Data Cable (DMX Cable) Requirements (For DMX and Master/Slave Operation):

Your fixture and your DMX controller require a standard 3-pin XLR connector for data input and data output (see figure below). Be sure to only use properly rated DMX cables for DMX operation and not standard audio cables. If you are constructing your own cables be sure to use two conductor shielded digital cable rated at a 120 ohms (this cable can be purchased at almost all professional sound and lighting stores). Your cables should be made with a male and female 3-pin XLR connector on either end of the cable.

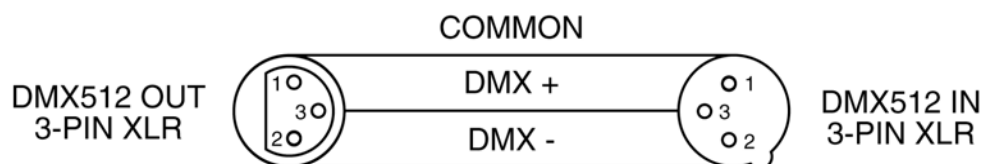

Please note: This is not the same as audio microphone cable. Audio cable has a different resistance rating

Be sure to follow the above figure when making your own cables. Do not use the ground lug on the XLR connector. Do not connect the cable's shield conductor to the ground lug or allow the shield conductor to come in contact with the XLR's outer casing. Grounding the shield could cause a short circuit and erratic behavior.

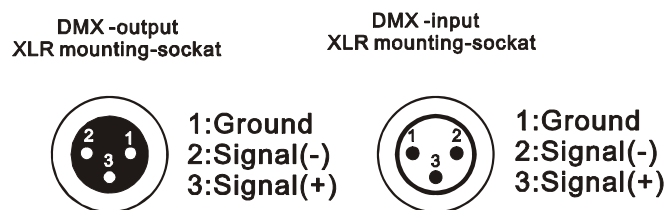

DMX-512 control connection

Connect the provided DMX XLR cable to the female 3-pin XLR output of your controller and the other side to the male 3-pin XLR input of the moving head (Please refer to the diagram below.). You can chain multiple moving heads together through serial linking. The cable needed should be two conductor, shielded cable with XLR input and output connectors. Always be sure daisy chain your in and out data connections, never split or “Y” your DMX connections unless you are using an approved DMX splitter such as the Elation Opto Branch

4™ or DMX Branch/4™.

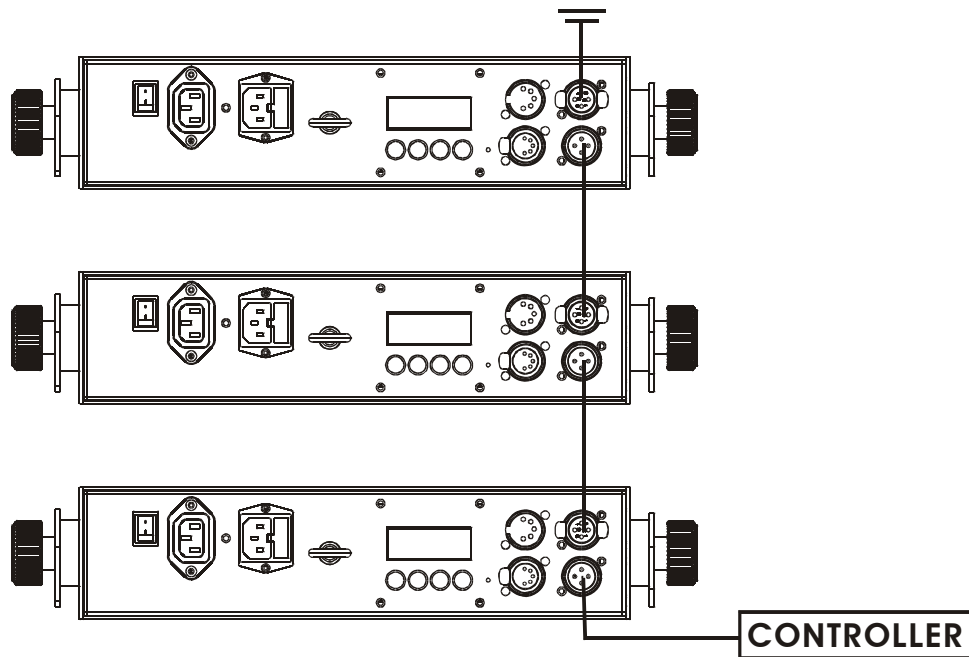

Please note: to ensure maximal stability, only two devices may be connected together in this manner! From the third devices, please connect to power supply to get power for the second link.

DMX-512 connection with DMX terminator

When longer runs of cable are used, you may need to use a terminator on the last fixture to avoid erratic behavior. A terminator is a 120 ohm 1/4 watt resistor that is connected between pins 2 and 3 of a male XLR connector (DATA + and DATA -). This fixture is inserted in the female XLR connector of the last fixture in your daisy chain to terminate the line. Using a cable terminator (Elation part number Z-DMX/T) will decrease the possibilities of erratic behavior.

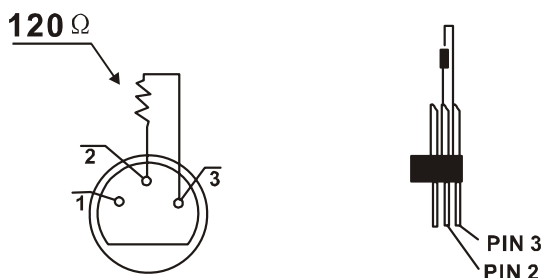

Termination reduces signal errors and avoids signal transmission problems and interference. It is always advisable to connect a DMX terminal, (Resistance 120 Ohm 1/4 W) between PIN 2 (DMX-) and PIN 3 (DMX +) of the last fixture.

5-Pin XLR DMX Connectors. Some manufactures use 5-pin XLR connectors for DATA transmission in place of 3-pin. 5-pin XLR fixtures may be implemented in a 3-pin XLR DMX line. When inserting standard 5-pin XLR connectors in to a 3-pin line a cable adaptor must be used, these adaptors are readily available at most electric stores. The chart on the next page details a proper cable conversion.

3-Pin XLR to 5-Pin XLR Conversion		
Conductor	3-Pin XLR Female (Out)	5-Pin XLR Male (In)
Ground/Shield	Pin 1	Pin 1
Data Compliment (- signal)	Pin 2	Pin 2
Data True (+ signal)	Pin 3	Pin 3
Not Used		Pin 4 - Do Not Use
Not Used		Pin 5 - Do Not Use

Understanding Fixture DMX addressing;

All fixtures should be given a DMX starting address when using a DMX controller, so the correct fixture responds to the correct control signal. This digital starting address is the channel number from which the fixture starts to “listen” to the digital control information sent out from the DMX controller. The allocation of this starting DMX address is achieved by setting the correct DMX address on the digital display located on the head of the fixture.

You can set the same starting address for all fixtures, or a group of fixtures, or set different address for each individual fixture. Be advised that setting all you fixtures to the same DMX address will subsequently control all fixtures in the same fashion, in other words, changing the settings of one channel will affect all the fixtures simultaneously.

If you set each fixture to a different DMX address, each unit will start to “listen” to the channel number you have set, based on the quantity of control channels (DMX channels) of each fixture. That means changing the settings of one channel will only affect the selected fixture.

In the case of the Design LED 12 Brick II ™, which is a 3 channel fixture (default), you should set the starting DMX address of the first unit to 1, the second unit to 4 (3 + 1), the third unit to 7 (4 + 3), and so on. The chart on page 20 details the proper starting DMX address dipswitch setting combination.

8. OPERATING MODES

This fixture can run in three different DMX modes, the following pages will detail the different operating modes as well as how to achieve the different operating modes.

DMX Settings: The chart below describes how to access the different DMX modes. The chart below also defines the how the channel will function in the different DMX modes.

1. DMX Mode:

Form 1

DMX Mode	LED Control model	LED channel	Internal program	Strobe	Dimmer/Speed
15 channel	Each control can be controlled alone	1~12	13	14	15
12 channel	Each control can be controlled alone	1~12	N/A	N/A	N/A
4 channel	Each color can be controlled	1~3	N/A	N/A	4
3 channel	Each color can be controlled	1~3	N/A	N/A	N/A

Specification:

When in 15 channel mode, the reciprocal 3rd, is the internal program channel, below the value:

0---10	No function
11---40	Program 1
41---70	Program 2
71---100	Program 3
101---130	Program 4
131---160	Program 5
161---190	Program 6
191---220	Program 7
221---255	Program 8

When in 15 channel mode, the reciprocal 2rd channel is the Strobe channel, below the value:

0	Open
1---95	Strobe from slow to fast
96---127	Open
128---159	Pulse strobe from slow to fast
160---191	Open
192---223	Random strobe

224---255

Open

If running the internal program, the tailender channel would be the speed of program from slow to fast.

If not running the internal program, the tailender channel would be dimmer channel.

2: Display menu:

MODE	<ADDR>	AXXX (1-512)	Set DMX address		
	<CHAN>	3 CH	Select 3 channel mode		
		4 CH	Select 4 channel mode		
		12CH	Select 12 channel mode		
		15CH	Select 15 channel mode		
<SLAV>	ON/OFF	Run as slave.			
MANU	<CNTL>	MAST	Run as master		
		ALON	Set to stand alone		
	<BLAC>		BLACKOUT		
	<COLR>	RED	RXXX	Adjust red LED Value	
		GREN	GXXX	Adjust green LED Value	
BLUE		BXXX	Adjust blue LED Value		
STRB		SXXX	Adjust strobe value		
CHAS	CHS1	SPED	XXX	Adjust speed of scene	
		FADE	XXX	Adjust speed of fade	
		STRB	XXX	Adjust speed of strobe	
	CHS2	SPED	XXX	Adjust speed of scene	
		FADE	XXX	Adjust speed of fade	
		STRB	XXX	Adjust speed of strobe	
	CHS3	SPED	XXX	Adjust speed of scene	
		FADE	XXX	Adjust speed of fade	
		STRB	XXX	Adjust speed of strobe	
	CHS4	SPED	XXX	Adjust speed of scene	
		FADE	XXX	Adjust speed of fade	
		STRB	XXX	Adjust speed of strobe	
	CHS5	SPED	XXX	Adjust speed of scene	
		FADE	XXX	Adjust speed of fade	
		STRB	XXX	Adjust speed of strobe	
	CHS6	SPED	XXX	Adjust speed of scene	

		FADE	XXX	Adjust speed of fade
		STRB	XXX	Adjust speed of strobe
	CHS7	SPED	XXX	Adjust speed of scene
		FADE	XXX	Adjust speed of fade
	CHS8	STRB	XXX	Adjust speed of fade
		SPED	XXX	Adjust speed of scene
		FADE	XXX	Adjust speed of fade
	SOND	CTRL	MAST	
ALON				Sound-controlled run in Stand Alone
MIC		M-XX		Microphone sensitivity
OTHR	<DIMR>	MOD1		Select standard dimmer
		MOD2		Select weak dimmer
	<LOAD>	yes		Reset to Fixture to the Factory Default Settings
	<VER>	V X.X		Show the version

Remark:

1) If there is no DMX data received in the device, the display will flash.

2) Instruction for the SPED and the FADE function in CHAS:

SPEED: The time one step would stay

FADE: The time that one step altered to next step

Example: we set SPEED = 1second, and FADE = 1second, the 1st step is Red 100% open, the 2nd step is green 100% open, the 3rd step is Blue 100% open. So, the Chase would come out as:

1, The Red 100% open and stay for 1second (SPEED)

2, Then Red drop down from 100% to 0%, the same time Green from 0% to 100%, in 1second (FADE)

3, The Green stay 100% for 1second

4, Then Green drop down from 100% to 0%, the same time Blue from 0% to 100%, in 1second (FADE)

5, Blue stay 100% for 1 second.

6, Then Blue drop down from 100% to 0%, the Red come up from 0% to 100%

Repetition operation

DMX Operation Notes:

The fixture will automatically function in DMX mode whenever the unit receives a DMX signal. Please note that this will override all manual settings regardless of dipswitch positions.

This unit will keep and retain the last DMX command in the event of DMX signal failure. To reset the fixture you must turn the power off.

9. DMX CHANNEL TRAITS

4 Channel Mode: This chart details a simple layout of the DMX channel assignment in 4-channel mode. The chart traits will vary slightly for 3-channel, 12-channel, and 15-channel operation, as those modes use more RGB channels for more precise control.

Channel mode 4:

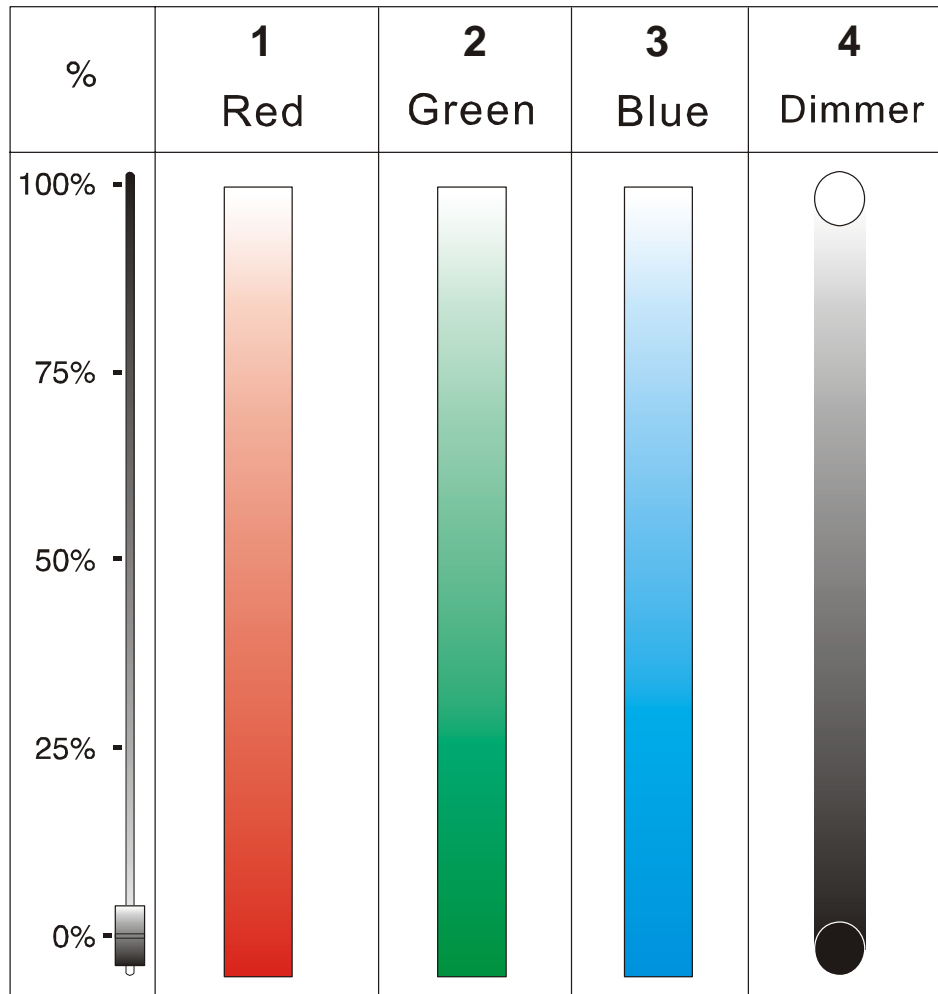

CHANNEL 1: Red

CHANNEL 2: Green

CHANNEL 3: Blue

CHANNEL 4: Dimming (0%-100%)

DMX channel's functions and their values (4 Channel Mode):

<u>Channel 1 - Red:</u>	
0-255	Red (0-Black, 255-100% Red)
<u>Channel 2 - Green:</u>	
0-255	Green (0-Black, 255- 100% Green)
<u>Channel 3 - Blue:</u>	
0-255	Blue (0-Black, 255- 100% Blue)
<u>Channel 4 - General dimming</u>	
0-255	Dimming (0%-100%) ~ <i>Normal Operation</i>

10. CLEANING AND MAINTENANCE

The consider the following point during normal service and inspection:

1. Be sure all screws and fasteners are securely tightened at all times. Lose screws may fall out during normal operation resulting in damage or injury as larger parts could fall.
2. Electric power supply cables must not show any damage, material fatigue or sediments. Never remove the ground prong from the power cable.

Further instructions depending on the installation spot and usage have to be adhered by a skilled installer and any safety problems have to be removed.



CAUTION!

Disconnect from mains before starting maintenance operation.

We recommend a frequent cleaning of the device. Please use a moist, lint- free cloth. Never use alcohol or solvents.

There are no user serviceable parts inside this, please refer all other service issues to an authorized Elation service technician.

Should you need any spare parts, please order genuine parts from your local dealer.

11.2-YEAR LIMITED WARRANTY

A. Elation Professional® hereby warrants, to the original purchaser, Elation Professional® products to be free of manufacturing defects in material and workmanship for a period of two years, (730 days) from the date of purchase. This warranty shall be valid only if the product is purchased within the United States of America, including possessions and territories. It is the owner's responsibility to establish the date and place of purchase by acceptable evidence, at the time service is sought.

B. For warranty service, send the product only to the Elation Professional® factory. All shipping charges must be pre-paid. If the requested repairs or service (including parts replacement) are within the terms of this warranty, Elation Professional® will pay return shipping charges only to a designated point within the United States. If the entire instrument is sent, it must be shipped in its original package. No accessories should be shipped with the product. If any accessories are shipped with the product, Elation Professional® shall have no liability what so ever for loss of or damage to any such accessories, nor for the safe return thereof.

C. This warranty is void if the serial number has been altered or removed; if the product is modified in any manner which Elation Professional® concludes, after inspection, affects the reliability of the product; if the product has been repaired or serviced by anyone other than the Elation Professional® factory unless prior written authorization was issued to purchaser by Elation Professional®; if the product is damaged because not properly maintained as set forth in the instruction manual.

D. This is not a service contract, and this warranty does not include maintenance, cleaning or periodic check-up. During the period specified above, Elation Professional® will replace defective parts at its expense, and will absorb all expenses for warranty service and repair labor by reason of defects in material or workmanship. The sole responsibility of Elation Professional® under this warranty shall be limited to the repair of the product, or replacement thereof, including parts, at the sole discretion of Elation Professional®. All products covered by this warranty were manufactured after January 1, 1990, and bare identifying marks to that

effect.

E. Elation Professional® reserves the right to make changes in design and/or improvements upon its products without any obligation to include these changes in any products theretofore manufactured.

F. No warranty, whether expressed or implied, is given or made with respect to any accessory supplied with products described above. Except to the extent prohibited by applicable law, all implied warranties made by Elation Professional® in connection with this product, including warranties of merchantability or fitness, are limited in duration to the warranty period set forth above. And no warranties, whether expressed or implied, including warranties of merchantability or fitness, shall apply to this product after said period has expired. The consumer's and or Dealer's sole remedy shall be such repair or replacement as is expressly provided above; and under no circumstances shall Elation Professional® be liable for any loss or damage, direct or consequential, arising out of the use of, or inability to use, this product.

G. This warranty is the only written warranty applicable to Elation Professional® Products and supersedes all prior warranties and written descriptions of warranty terms and conditions heretofore published.

12. PHOTOMETRIC DATA

Beam angle 44°

Intensity (LUX)

480

144

76

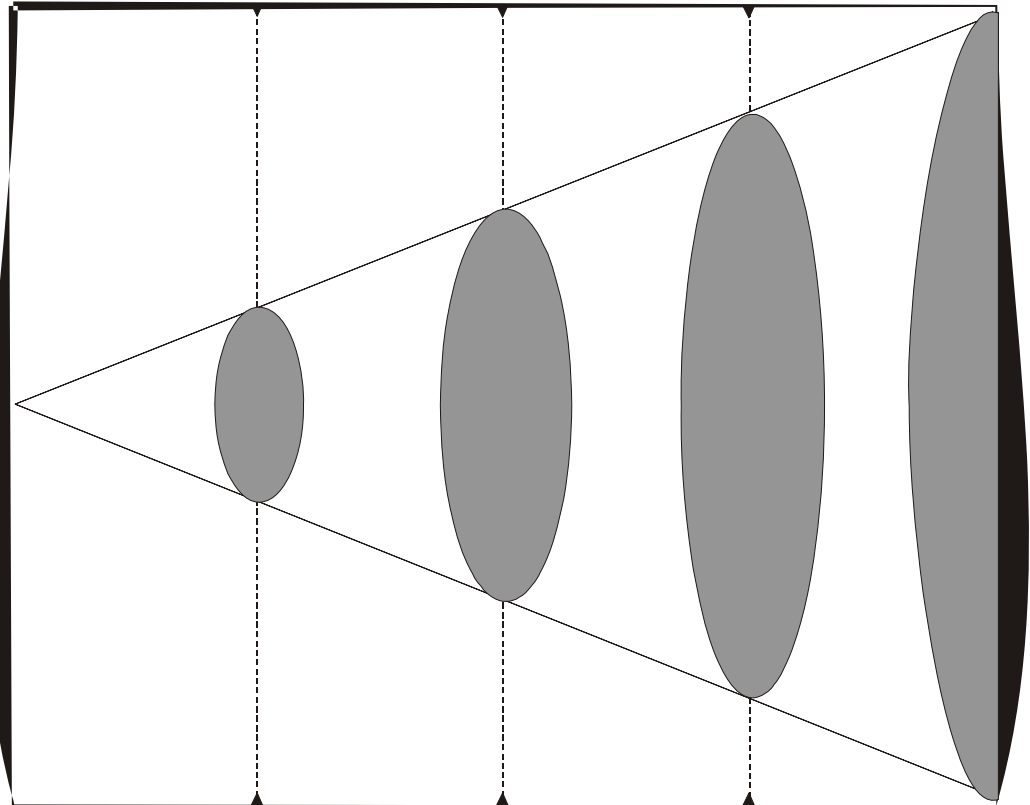

Distance (m) 0
Diameter (m) 0

1
∅ 0.8

2
∅ 1.6

3
∅ 2.4

15. DIMENSIONAL DRAWINGS

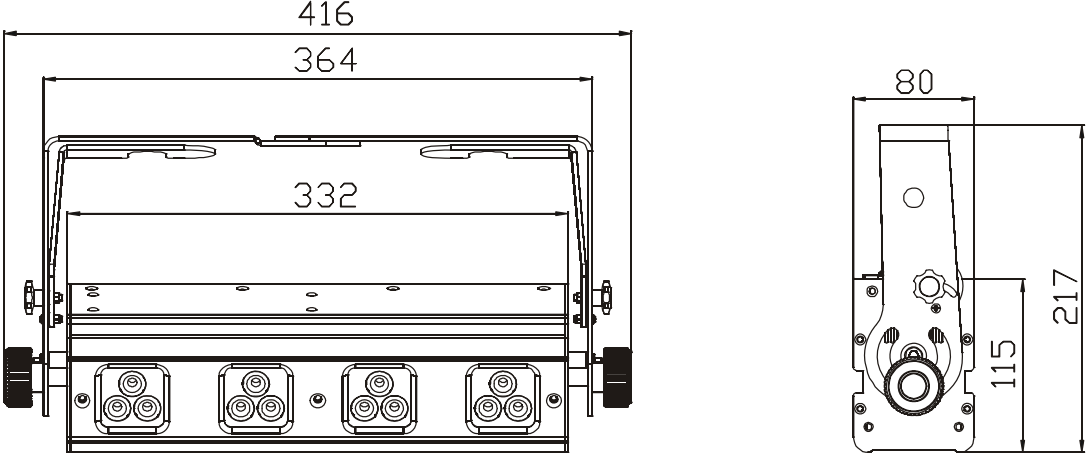

14. CHANGE LENS TO GET DIFFERENT BEAM ANGLES

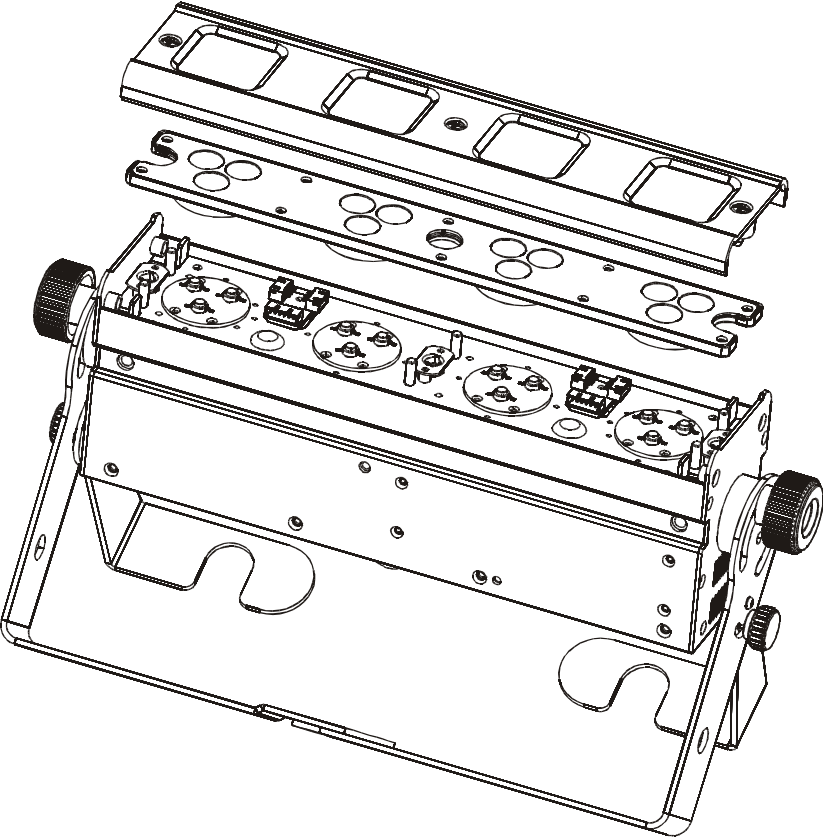

15. CIRCUIT SCHEMATIC

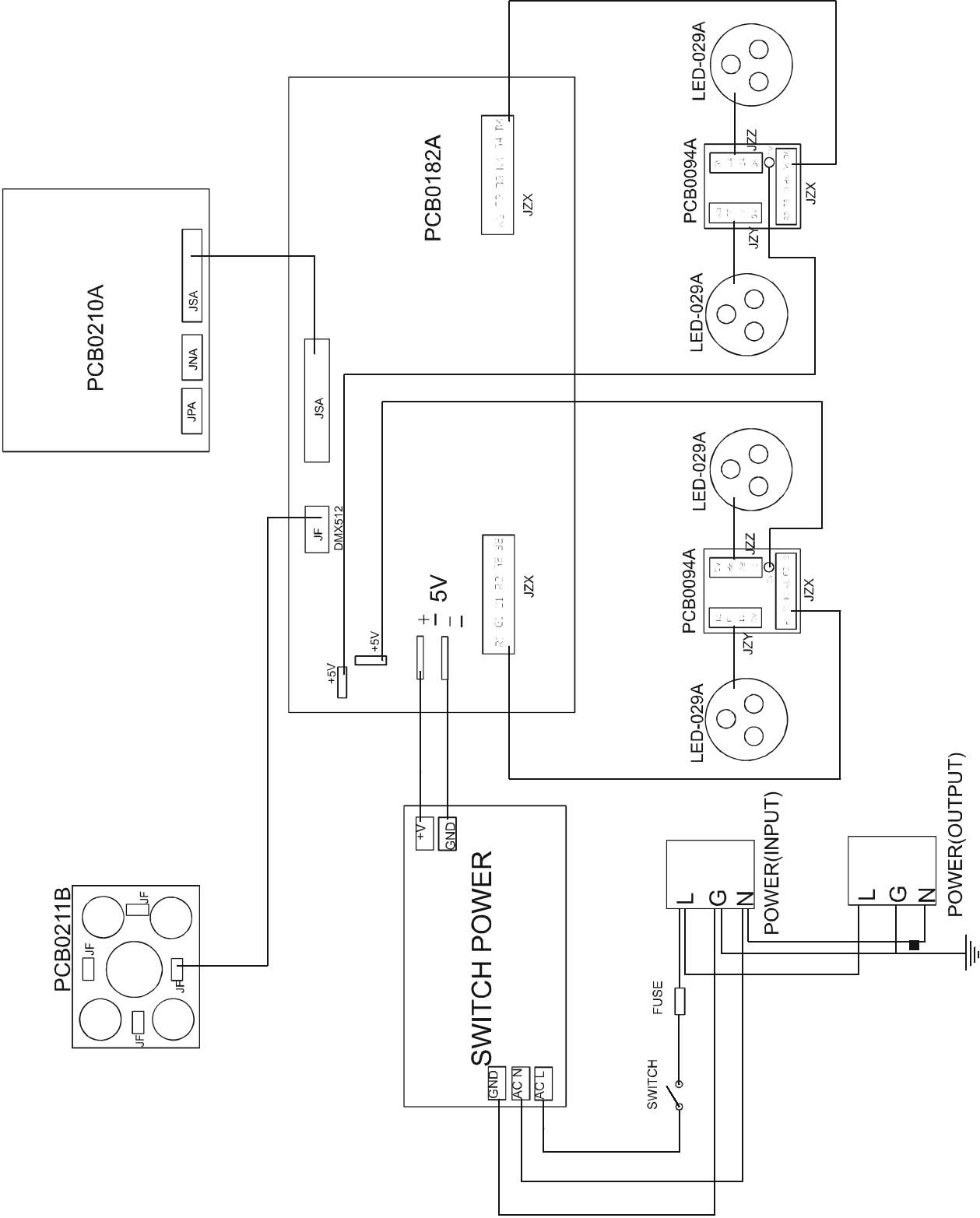

16. TECHNICAL SPECIFICATIONS

<i>Power supply:</i>	<i>100V~240V AC, 50Hz~60Hz</i>
<i>Power consumption:</i>	<i>MAX 30w</i>
<i>LED Configuration:</i>	<i>12 1Watt Units (4 x Red, 4x Green 4 x Blue)</i>
<i>Packing dimensions:</i>	<i>47x26.5x16cm (57x47x36cm ~ 4pc system)</i>
<i>Weight:</i>	<i>3.5Kgs / 7.72 Lbs (14Kgs ~ 4pc system)</i>
<i>DMX Channels:</i>	<i>3, 4, 12, 15 DMX Channel modes</i>
<i>Drive:</i>	<i>Standard DMX-512, 3 pole XLR; [+] = Pin 3, [-] = Pin 2, [Ground] = Pin 1 or Standard DMX-512, 5 pole XLR; n/a = Pin 5, n/a = Pin 4, [+] = Pin 3, [-] = Pin 2, [Ground] = Pin-</i>
<i>Color Mixing:</i>	<i>RGB Color Additive Mixing</i>
<i>Beam Angle:</i>	<i>44°</i>
<i>Fuse:</i>	<i>GMA 250V~2A</i>
<i>Dimmer:</i>	<i>Continuous Dimming 0~100%</i>
<i>Strobe:</i>	<i>Electronic Strobe 0~18 Fps</i>
<i>Lamp Life:</i>	<i>100,000 Hours Rated Life</i>

Please Note: Specifications and improvements in the design of this unit and this manual are subject to change without any prior written notice.

Elation Professional
6122 S. Eastern Ave.
Los Angeles, CA. 90040
323-582-3322 / 323-582-3108 fax
www.ElationLighting.com /Info@ElationLightng.com