

 **AUDIOVOX®**
Cellular telephones

MVX-500

 **AUDIOVOX®**
Cellular telephones

150 Marcus Blvd. Hauppauge, NY 11788

PRINTED IN JAPAN 9-91

**HANDHELD
PORTABLE
CELLULAR
TELEPHONE**

**OWNER'S OPERATING
INSTRUCTIONS**

TABLE OF CONTENTS

SYSTEM CONFIGURATION	6
BATTERY INSTALLATION AND RECHARGING	7
To Attach Battery Pack	
To Detach Battery Pack	
To Recharge Battery	
PRECAUTIONS	9
GENERAL SPECIFICATIONS	10
FEATURES AND OPTIONS	11
FUNCTIONS	12
BASIC OPERATION	14
Turning the Unit On/Off	
• Antenna Position	
• Receiving Signal Strength Indicator	
• Battery Level Indicator	
To Store a Number in Memory	
To Recall a Number from Memory	
To Review the Prefix	
Display Own Telephone Number	
Repertory Memory Scroll	
Automatic Storing into a Vacant Memory Address	
Secret Memory	
To Lock the Unit	
Automatic Lock (NAM Option)	
To Unlock the Unit	
Backlighting On/Off Control	
Volume Control	
MEMORY NAME TAG	19
To Enter Names using Alpha (Letters)	
To Store Name with Phone Number	
To Recall from Memory with Name	
ALPHA SEARCH	21
PLACING TELEPHONE CALLS	22
To Place a Call	
If the Call Fails to Go Through	
Automatic Redial (NAM Option)	
Terminating a Call	
To Receive Calls	
Silent Incoming Calls	
Any Digit Key Answering (NAM Option)	
Automatic Answering	
To Place a Call with a Number in the Memory	
911 Emergency Call (NAM Option)	
To Mute a Phone Conversation	

ONE TOUCH DIALING	24
To Store a Number into One Touch Memory	
To Place a Call to a Number in One Touch Memory	
CALL RESTRICTION (NAM OPTION)	25
To Set Call Restricted Mode	
To Exit Call Restriction Programming Mode	
END-TO-END SIGNALING	26
Touch Tone™ from Memory	
Link Dialing	
SCRATCH-PAD DIALING	28
SCRATCH-PAD DIALING	
WITHOUT KEYING TONES	28
CALL TIME DISPLAY	29
To Display the Talk Time of the Last Call	
To Display the Cumulative Talk Time	
To Display the Number of Calls	
To Clear the Timer	
One Minute Beep (NAM Option)	
A/B SYSTEM SELECTION	30
SYSTEM INHIBIT (NAM OPTION)	31
MULTIPLE CITY REGISTRATION	31
RADIO FREQUENCY (RF)	
CHANNEL INDICATOR	32
LAST RESCAN SID INDICATOR	32
FUNCTION REVIEW	33
IMPORTANT SAFETY INFORMATION	34
WARNING	34

Touch Tone™ is a registered trade mark of AT & T.

AUDIOVOX MINI HANDHELD PORTABLE CELLULAR TELEPHONE

Audiovox introduces Minivox, MVX-500, one of the smallest mini portable cellular phones in the world.

It weighs a feather-light 10.6 ozs. and provides approximately 65 minutes of talk time and 12 hours of standby time. The optional extended life battery give you up to 120 minutes of talk time and 20 hours of standby time.

The Minivox MVX-500 delivers exceptionally high performance in one very compact package. Audiovox has utilized the latest in micro electronic technology to deliver a handheld portable phone that is over 35% smaller and lighter than previous models.

Minivox is the slimmest phone on the market today and it will fit neatly into you pocket or purse. The entire cellular electronics and transceiver are built right into the remarkably slim handset (only 0.7 inches thick).

The Minivox is packed with features. Its dual position antenna enables calls to be made or received while the antenna is in the down position. It has two-one touch speed dialing keys, a battery level indicator, large send and end keys and a "stay alive" feature that gives the user time to change batteries without losing the call.

The MVX-500 also features "any digit key" answer that allows you to push any digit key to answer the phone.

Optional accessories include and extended life battery, travel trickle charger (for greater portability when away from home), leather carrying case and a hands-free car kit for in vehicle use with a RJ11 Jack.

The Minivox also comes with something only an Audiovox phone can give you... a "where ever you need us" nationwide network of cellular service centers, ready whenever you need us.

SYSTEM CONFIGURATION

System configuration and the equipment list are as shown below.

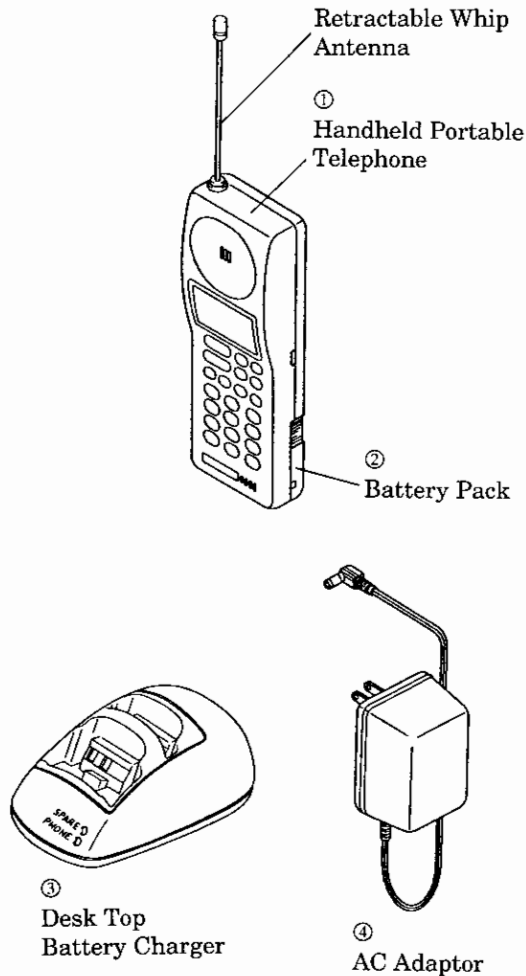

List of Equipment

No.	Name of the Equipment
①	Handheld Portable Telephone
②	Battery Pack
③	Desk Top Battery Charger (DTC-500)
④	AC Adaptor (CNR-500)

BATTERY INSTALLATION AND RECHARGING

The Portable Telephone contains a Detachable Battery Pack (BTR-500). Fully charged Battery Pack offers approximately 65 minutes Talk Time or 12 hours standby.

It is recommended to carry one fully charged spare Battery Pack for longer operation. (Additional Battery Packs may be purchased at your Cellular Telephone Dealer.)

To Attach Battery Pack

- (1) Position Battery Pack to the unit using the indents on the Battery Pack as guides to the lower end of the unit as shown by arrow ①.
- (2) Press and slide the Battery Pack as shown by arrow ② to lock the Battery Pack to the unit.

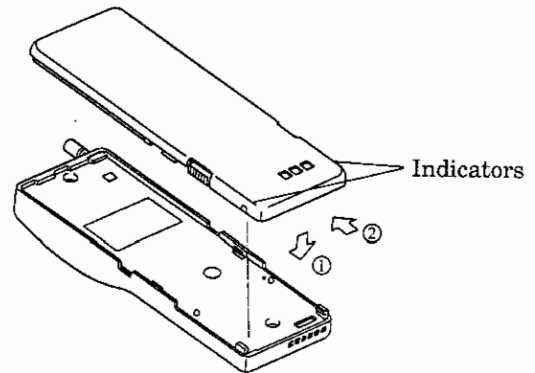

To Detach Battery Pack

- (1) Press the Release Buttons on both sides of the Battery Pack as indicated by arrow ① while sliding it down approximately 1/4" as shown by arrow ②.
- (2) Then lift up to remove the Battery Pack from the unit.

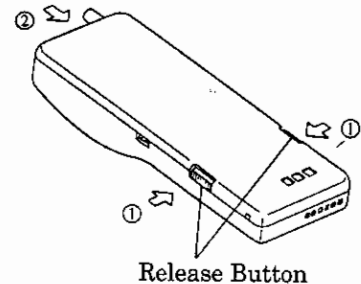

To Recharge Battery

Desk Top Battery Charger (DTC-500) can recharge spare Battery and the Battery connected to the Portable Telephone at the same time. Moreover, the Battery Charger can recharge an optional Extended Life Battery (BTE-500). DC voltage is supplied by the separate AC Adaptor.

1. Two LEDs (Light Emitting Diode) on the Desk Top Battery Charger light green when DC voltage is supplied from the AC Adaptor.
2. The Battery charging starts when the Portable Phone and/or a spare Battery are/is placed into the Battery Charger, the LED(s) light(s) red.
3. When the charging is finished, the LED(s) return(s) to as follows:

	LED(s)	Charging Time
Standard Battery (BTR-500)	Orange	Approx. 8 hours
Extended Life Battery (BTE-500)	Green	Approx. 11 hours

- Note: (1) Environmental temperature for battery recharging: 0 ~ +45°C
(2) We recommend you to turn off the power of the telephone to secure complete recharging of the battery.

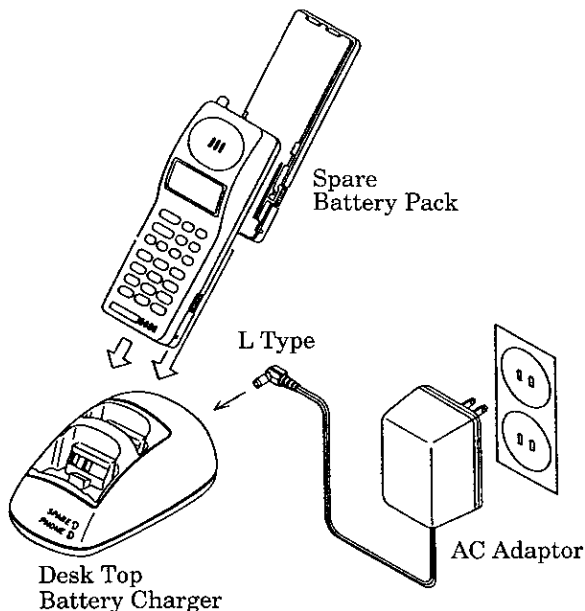

PRECAUTIONS

Your Handheld Portable Telephone is a high quality piece of equipment. Before operating the equipment, please take the following precautions.

1. Don't use this equipment in an extreme environment where high temperature or high humidity exists.
2. Don't abuse the equipment. Avoid striking, shaking or shocking. When not using the unit, lay down the unit to avoid possible damage due to instability.
3. Don't expose this equipment to rain or spilled beverages.
4. Recharge the battery fully before your first use of the unit.
5. When the battery becomes discharged, two beep tones will be heard every 10 seconds, and the display will show **Discharged**. Replace the discharged battery with a fully charged one, and recharge the discharged battery.
Note: When the battery becomes discharged during a conversation, you can continue your conversation without redialing if a discharged battery was replaced with a charged one within 3 seconds (before cell site disconnects).
6. To ensure long battery life, operate the unit until **Discharged** is displayed, then recharging the battery. Remove Battery Pack from the unit when it is not expected to be used for a long period. Recharging at least once every month is recommended when not being used.

GENERAL SPECIFICATIONS

(Subject to change without notice)

Frequency Range : 824 to 849 MHz, Transmit
869 to 894 MHz, Receive

Number of RF Channels : 832, Full Duplex

Channel Spacing : 30 KHz

Duplex Spacing : 45 MHz

Frequency Stability : ± 2.5 PPM

RF Output Power : 0.6W ERP With Power Control

Receiver Sensitivity : -116 dBm (12 dB SINAD)

Modulation/Demodulation : Voice PM (With Compressor)
Data FM

Operating Temperature : -20°C to $+60^{\circ}\text{C}$

Supply Voltage : 6.0 V
(NiCd Battery 1.2 V x 5,
600 mA)

Current Drain : In Use;
Approx. 500 mA
Standby;
Approx. 50 mA

Operating Time : Talk;
Approx. 65 min.
(at full power output)
Standby;
Approx. 12 hours

Size : Approx.
18 (H) x 56 (W) x 165 (D) mm
0.7 (H) x 2.2 (W) x 6.5 (D) inch

Weight : Approx. 300 gr (10.6 oz)

FEATURES AND OPTIONS

- Push Button Dialing
- Backlit Keypad and Display with On/Off Control
- Large Size Dot-matrix LCD Display
 - Status/Function Indicator
 - 15 Digits Dial Number
 - Receiving Signal Strength Indicator
- Battery Level Indicator
- (Electronic) Volume Control
- Pre-set Dialing up to 16 Digits (32 Digits: NAM Option)
- Extended Readability (Prefix Review)
- Last Digit Clear
- Digit Display Clear
- 911 Emergency Call in all modes
- Repertory Dialing: 16/80-Digit 99 Memories
- Repertory Memory Scroll
- Automatic Storing into a Vacant Memory Address
- Secret Memory
- Memory Name Tag
- Alpha Search
- Linked Preset Dialing from Memory
- One Touch Dialing
- Any Digit Key Answering (NAM Option)
- Automatic Answering
- Last Number Redial **Press [END], [SEND]**
- Automatic Redial (NAM Option)
- Mute or Hold
- Scratch-pad Dialing (with/without Keying Tones)
- End-to-End Signaling
- Touch Tone™ from Memory
- Continuous DTMF from Keypad
- Call Restrictions (NAM Option)
- Silent Incoming Calls
- Call Time Display (Five Functions)
- Display Own Telephone Number
- Multiple A/B System Selection
- System Inhibit (NAM Option)
- Multiple City Registration
- Last Rescan SID Indicator
- RF Channel Indicator
- Electronic Lock
- Automatic Lock (NAM Option)
- Function Review

FUNCTIONS

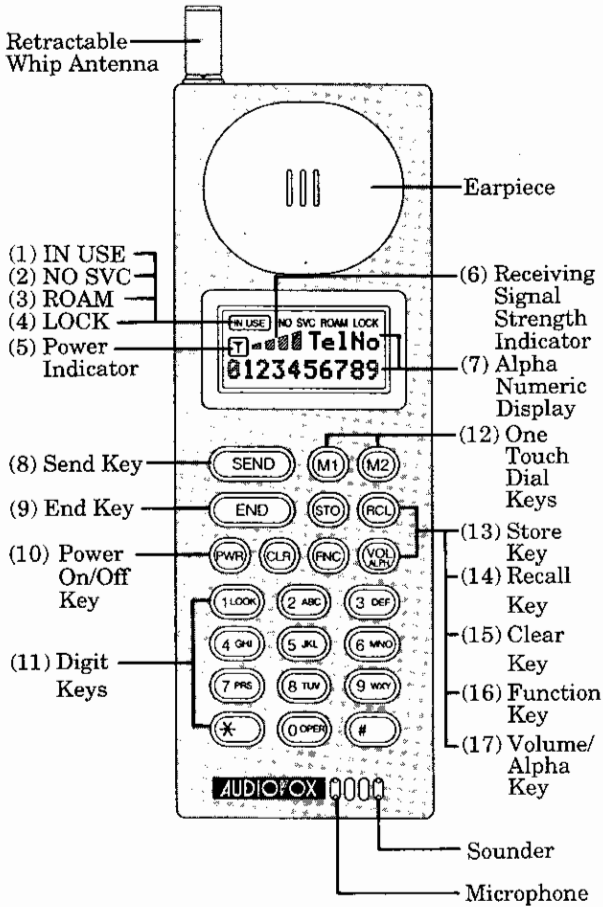

- (1) **INUSE** indicator lights when a call is in progress.
- (2) **NOSVC** (no service) indicator lights when the unit is in a non-coverage area.
- (3) **ROAM** indicator lights when the unit is out of the home area.
- (4) **LOCK** indicator lights when the unit is locked.
- (5) **Y** is used as a POWER ON indicator which lights when the unit is turned on.
- (6) RECEIVING SIGNAL STRENGTH INDICATOR:
The number of shaded blocks indicates the Receiving Signal Strength.
- (7) 15-CHARACTER FUNCTIONAL ALPHA-NUMERIC DISPLAY:
First 5 characters indicate current function and status conditions.
The remaining 10 characters show the last 10 digits of the dialed number.
- (8) **SEND** (send key) is used for placing or receiving a call.
- (9) **END** (end key) terminates a call.
- (10) **PWR** (power on/off key) is used to turn on/off the unit.
- (11) DIGIT KEYS to enter a phone number.
- (12) **M1**, **M2** (one-touch keys) allows you to place a call with a single key stroke.
- (13) **STO** (store key) stores phone numbers in repertory memory.
- (14) **RCL** (recall key) recalls phone numbers from repertory memory.
- (15) **CLR** (clear key) clears the digit(s) from the display.
- (16) **FNC** (function key) shifts the digit keys to the functional keys.
- (17) **VOL/ALPH** (volume/alpha key) is used to control Earpiece audio level as well as the Alert Tone. **VOL** is also used as **ALPH** (alpha key) in combination with **FNC** to enter 5 Alphabetical characters.

BASIC OPERATION

Turning the Unit On/Off

Press **PWR** for about one second to turn on the unit. The indicator **Y** will light (all indicators will light momentarily: display will show your phone number, and a tone will be heard). Press **PWR** again for about one second to turn off the unit.

• Antenna Position

Your portable cellular telephone has been equipped with a dual position antenna system.

This dual position antenna has been especially designed to allow your phone to receive calls while the antenna is down. However, for optimum performance and signal strength or while operating in poor signal areas, it is recommended that the antenna be fully extended.

Note: The antenna can be used in its fully extended or fully retracted position only.

• Receiving Signal Strength Indicator

The number of shaded blocks indicates the Signal Strength in your area. Four blocks show the maximum level. The display will vary as you move with the unit. If the signal is not strong enough to place a call, the **NOSVC** indicator will appear on the readout.

• Battery Level Indicator

You can monitor the current battery voltage level. Press **RCL**, key ***** then **6**, the battery voltage condition will be displayed on the readout in one of four steps for 5 sec..

The number of shaded blocks indicates the battery condition as follows:

B ■■■■	Full charge
B ■■■■ -	Normal phone call
B ■■■ - -	Short phone call
B ■ - - -	Recharge battery

To Store a Number in Memory

1. Press **CLR**, then enter the phone number.
2. Press **STO**, then enter the memory address (01 through 99).

Example: Press **STO**, key **1** then **5**, the displayed number will be stored into memory address 15.

Note: A number of more than 16 digits can be stored only into memory address 91 through 99.

To Recall a Number from Memory

Press **RCL**, then enter the memory address (01 through 99).

Example: Press **RCL**, key **1** then **5**, the number stored in memory address 15 will be displayed on the readout.

To Review the Prefix

(Number longer than 10 digits)

After pressing **RCL**, hold down the second digit of the memory address.

Note: When a set of linked numbers is recalled, you can review only the last linked number by this feature. To review Link 1 to Link 5, use **FNC**, **RCL** then key **X** (X is 1 to 5). See "Link Dialing".

Display Own Telephone Number

You can see your system ID number and your own phone number on the readout. Press **RCL**, key ***** then ***** again. The System ID number is shown while pressing key ***** at the 2nd time.

Repertory Memory Scroll

This feature is useful in finding a certain phone number by scrolling the repertory memory from one of the designated starting addresses.

1. Press **RCL**, key **X** then **#**.
X is the digit to assign the starting address as follows.

X	Starting address
0	01
1	11
2	21
.	.
.	.
.	.
8	81
9	91

2. Press **#** or *****.

#: Scroll upward (with roll back to 01)

*****: Scroll downward (with roll up to 99)

Memory address and the last 7 digits of the stored number will be displayed on the readout as follows.

Example: **31-1234567**

Address No. Tel. No.

Note: In this scroll feature, any vacant memory address(es) will be skipped.

Automatic Storing into a Vacant Memory Address

This feature allows automatic storing into a vacant repertory memory address. This ends the possible problem of writing over a previously stored number.

1. Enter the phone number.
2. Press **STO**.
3. Enter the memory address group number in which you want to store a number.

0 :	From 01 to 10
1 :	From 11 to 20
2 :	From 21 to 30
.	.
.	.
.	.
8 :	From 81 to 90
9 :	From 91 to 99
* :	From 01 to 99

4. Press **#**.

The memory address and the last 7 digits of the stored phone number will be displayed on the readout as follows.

Example: **31-1234567**

Note: If there is no vacant address in the assigned area, the phone number will not be stored in the memory.

Secret Memory

This feature allows you to store ID code, telephone credit card numbers, etc. in secret memory locations. For security purposes, you must enter your three-digit security code to display the secret number. For practical use of the secret memory, refer to "END-TO-END SIGNALING".

To Store the Secret Number

1. Press **CLR**, then enter secret number.
2. Press **FNC**, **STO**, then enter the memory address (01 through 99). **SECRET** will be displayed on the readout.

Example: To store the secret number 9876 into memory address 41 or automatically store this number into a vacant memory address of 40's.

1. Press **CLR**.
2. Enter secret number **9 8 7 6**
3. Press **FNC**, **STO**. (secret memory store)
4. Press keys **4**, **1**. (address number)

or

press keys **4**, **#**. (to store vacant memory address of 40's)

41-SECRET

To Confirm the Secret Number

1. Enter the three-digit security code.
2. Press **RCL**, then enter the memory address (01 through 99). The last 10 digits of the secret number will be displayed on the readout.

Example: To confirm the secret number stored into memory address 41.

1. Enter the three-digit security code **1 2 3**.
2. Press **RCL**, key **4** then **1**.

Note: If you recall the secret memory without the three-digit security code, the secret number is not displayed on the readout as shown below:

Press **RCL**, key **4** then **1**.

SECRET

or

Press **RCL**, key **4** then **#**.

41-SECRET

To Lock the Unit

Press **FNC**, then key **1** (LOCK).

The **LOCK** indicator lights. The unit will remain locked until unlocked, even if the power is turned off.

Automatic Lock (NAM Option)

If you request the feature of Automatic Lock, your NAM can be programmed so that your unit will automatically go into the locked condition when the power of the unit is turned "off". When **PWR** is turned "on", the unlock code is required to operate the unit.

To Unlock the Unit

Enter the three-digit unlock code. The **LOCK** indicator will go out when the three-digit code is the same as the code registered in the NAM.

Backlighting On/Off Control

LCD display and the keypad are backlit automatically after the Power-On. If needed, backlighting can be turned off by pressing **FCL**, key ***** then **5**.

Even if the unit is in the backlighting "Off" mode, the backlighting will be turned on again automatically for 10 seconds when any key operation is conducted or a call is received.

To return to the backlighting "On" mode, press **FCL**, key ***** then **5** again.

Volume Control

The audio level of the earpiece and the alert tone can be adjusted by the Volume Control Key **VOL**.

• Earpiece:

Keep pressing **VOL** until you get the desired sound level.

Sound level will be displayed on the readout digitally during the level adjustment and the sample tone will indicate the sound level when you are not engaged in a telephone conversation. The display format is as follows.

H.S [] (1 to 9)

• Alert Tone:

Press **FCL**, key ***** then **6**.

Then adjust the alert tone level in the same manner as above. Your telephone will ring at the new level. In this case, the display format is as follows.

ALT [] (1 to 9)

MEMORY NAME TAG

This feature permits you to tag an identifying name (in up to 5 characters) to each phone number in the memory address. The name will be displayed each time you recall a number from memory address.

To Enter Names using Alpha (Letters)

1. Press **FNC**, then **ALPH**. **Alpha** will appear on the readout to indicate the Alpha Mode is active.
2. Press digit keys repeatedly until the character you need appears. The following table shows which character is assigned with each digit key.

Key	ASSIGNED ALPHA CHARACTERS				
1	(Blank)	.	-	1	
2 (ABC)	A	B	C	2	
3 (DEF)	D	E	F	3	
4 (GHI)	G	H	I	4	
5 (JKL)	J	K	L	5	
6 (MNO)	M	N	O	6	
7 (PRS)	P	Q	R	S	7
8 (TUV)	T	U	V	8	
9 (WXY)	W	X	Y	Z	9
0	0				
*	*				
#	#				

3. When the character you need is displayed, press **ALPH** to move to the next space.
4. Go back to step 2, and repeat the same procedures until the complete character name is displayed.
5. When an entry error is made, press **CLR** momentarily to erase the last character. If you press **CLR** more than a second, all characters on the readout will be erased.
6. To exit Alpha Mode, press **FNC**, then **ALPH**.

To Store Name with Phone Number

1. Enter the phone number.
2. Press **FNC**, then **ALPH** to set Alpha Mode.
3. Enter the name you need. (Refer to "To Enter Names using Alpha".)
4. Press **STO**, then enter the memory address (01 through 99), to store the number with the name into memory.

Note: If you enter the phone number after entering the name, the name will be erased.

Example: To store the phone number 123-4567 with the name JOHN into memory address 15.

1. Enter the phone number;

1	2	3	4	5	6	7
---	---	---	---	---	---	---
2. Set Alpha Mode;

FNC	ALPH
-----	------
3. Enter the Name;

5	ALPH	6	6	6	ALPH
(J)		(O)			
4	4	ALPH	6	6	ALPH
(H)		(N)			
4. Store the Number;

STO	1	5
-----	---	---

To Recall from Memory with Name

Recalling from the repertory memory with name is identical to standard repertory recall. When the number is recalled, the display will show the Alpha Name Tag as well as the stored phone number.

ALPHA SEARCH

This feature permits you to find a phone number stored in the memory by the first character of the Alpha Name Tag. This search can retrieve all entries beginning with the assigned initial character.

1. Press **FNC**, then **ALPH** to set the Alpha Mode.
2. Enter the initial character, by which you need to search the phone number.
3. Press **RCL**, then **ALPH**. The display will show the first entry whose Name Tag begins with the assigned initial character, and which is stored in the lowest memory address. Display shows Name Tag, Memory Address and Phone Number.
4. Press **↑** or **↓**.
 - ↑**: Scroll memory address upward.
 - ↓**: Scroll memory address downward.

Example:
Operation

FNC **ALPH**

5

RCL **ALPH**

↑

↑

↓

↓

↓

↓

Display

Alpha

J

JOHN

01-4567890

JACK

05-7654321

JAMES

15-9876543

JIM

99-8765432

PLACING TELEPHONE CALLS

To Place a Call

1. Enter the phone number. The last 15 digits of the dialed number are displayed on the readout.
Note: After 120 sec., display will return to the 10-digit display mode.
2. If a dialing error is made, press **CLR**, then enter the phone number again. Pressing **CLR** momentarily (less than approx. 0.5 sec.) clears only the last digit.
3. Press **SEND**. The **INUSE** indicator will light. When the called party answers, proceed with your conversation.

Note: If assigned in NAM, the phone number can be pre-set up to 32 digits. However, in this case it is necessary to confirm with system operator whether such service is available or not.

If the Call Fails to Go Through

1. If you hear the “reorder” signal, press **END**, then if there were no dialing errors, press **SEND** for redial. (Redialing with digit keys is not necessary.)
2. If the “intercept” signal is heard, press **END**, then redial the correct number.

Automatic Redial (NAM Option)

If the feature of Automatic Redial (NAM Option) is selected, your unit will automatically make five attempts to reach the cell site when the first try is not successful. The **INUSE** indicator will stay on, but the speaker will be muted for twenty seconds. This is done so that you do not hear the reorder signals out of the speaker. If you need to terminate the automatic redial, press **END**.

Terminating a Call

Press **END** and the **INUSE** indicator will go out.

To Receive Calls

1. When the telephone rings, press **SEND** to answer the call. The **INUSE** indicator will light.

Silent Incoming Calls

This feature alerts you visually of an incoming call by flashing **CALL** on the readout instead of hearing the Alert Tone.

1. Press **RCL**, key ***** then **7**. The **SALT** will appear on the readout.
2. When a call is received, the unit indicates it by flashing **CALL** on the readout without Alert Tone.
3. Press **SEND** to answer the call. **CALL** on the readout will go out.
4. This mode is deactivated by pressing **RCL**, key ***** then **7** again.
5. If the Silent Incoming Calls is activated when the unit is powered up, **SALT** will appear on the readout for 5 seconds.

Any Digit Key Answering (NAM Option)

This feature permits you to answer a call by pressing any digit keys the same as pressing **SEND**.

Automatic Answering

With this feature, the incoming call will be automatically connected for operation after two alert tones, and the **INUSE** indicator will light on the readout. Then the unit is ready for conversation.

1. To activate this mode, press **FNC** and then key **5**. **AAns** will appear on the readout.
2. This mode is deactivated when **FNC** and then key **5** are pressed again.
3. This feature will not function if the unit is in the Lock and Silent Incoming Calls.
4. If the Automatic Answering is activated when the unit is powered up, **AAns** will appear on the readout for 5 seconds.

To Place a Call with a Number in the Memory

1. Press **RCL**, then enter the memory address (01 through 99). The last 10 digits of the number will appear on the readout. If the number is longer than 10 digits, hold down the second digit of the memory address (after pressing **RCL**) to see the prefix.

Note: See “To Recall a Number from Memory” and “To Review the Prefix” for more details.

2. Press **SEND**. The **INUSE** indicator will light as the call is placed.

911 Emergency Call (NAM Option)

This feature permits you to place an emergency call (911) even if your telephone unit has been set to the Lock Mode or Call Restriction Mode.

Operation in Lock Mode

1. Enter the emergency call number (911); **[9] [1] [1]** ("911" does not indicate, but the **LOCK** indicator will light.)
2. Press **SEND**, the **INUSE** indicator will light.
3. To terminate the call, press **END**. (The **INUSE** indicator will go out.)

Operation in Call Restriction Mode

The operation and display are the same as in the normal mode.

To Mute a Phone Conversation

1. Press **FNC**, then key **[8]**. **Mute** will appear on the readout. The transmit audio will be muted and the receive audio will be heard from the receiver. You may converse privately with a passenger during a call.
2. To return to normal conversation: Press **FNC**, then key **[8]** again.
3. Mute is reset when the call is terminated.

ONE TOUCH DIALING

This feature permits you to place a call by a single key stroke.

To Store a Number into One Touch Memory

1. Press **CLR**, then enter a phone number.
2. Press **STO**, then one of the two One Touch Keys (**M1** or **M2**).
Stored numbers can be reviewed by pressing **RCL** then the One Touch Key you want to review.

To Place a Call to a Number in One Touch Memory

Press the One Touch Key for approx. 0.5sec.. The last 10 digits of the number will be displayed on the readout, and the **INUSE** indicator will light as a call is placed.

CALL RESTRICTION (NAM OPTION)

This feature permits you to impose various kinds of restrictions on Outgoing Calls.

To Set Call Restricted Mode

Enter the three-digit security code, then press **FNC**, key **[#]** then **[7]**.

The following key operation is needed to activate one of the restricted modes:

- [1]**: Only phone numbers having 11 digits or less are accepted. Operator assisted dialing is prohibited.
- [2]**: Only phone numbers having 7 digits or less are accepted. Operator assisted dialing is prohibited.
- [3]**: Operator assisted dialing (0 Origination) is prohibited.
- [4]**: No phone calls can be placed except for repertory dialing from memory address 01 to 09. However, emergency call by "911" will be available.
- [5]**: Only One Touch dialing is permitted. However, emergency call with "911" are available.
- [0]**: No restriction.

To Exit Call Restriction Programming Mode

Press **FNC**, then **CLR**.

- Note: (1) When in the restriction mode 4, number storage into the memory will not be permitted.
- (2) In the restriction mode, a short beep tone will be heard to inform you of the improper operation, and the word **Restricted** will be shown on the readout.

END-TO-END SIGNALING

This feature permits you to utilize additional phone services, such as accessing an alternate long distance network, signaling pager, or banking by phone etc.. For these services the signaling should be in DTMF (Touch Tone™). The following two features will make it easier to send in DTMF codes.

Note: When you use this feature with a secret number, the number must be previously stored in a memory address. (Refer to "To Store the Secret Number".)

Touch Tone™ from Memory

DTMF signaling by repertory dialing is available while engaged in a telephone conversation.

1. Press **RCL RCL**, then enter the repertory memory address (01 through 99).
The last 10 digits of the number will appear on the readout.

Note: However, if the memory address entered has been set as a secret memory, **SECRET** will be displayed on the readout instead of the number.

2. Press **SEND**. Then DTMF signaling will be placed and the DTMF tone can be monitored through the speaker.

Note: Continuous DTMF from keypad can be manually dialed as well to access answering machines when engaged in a telephone call.

Link Dialing

This feature permits you to pre-set from repertory memory or the keypad up to five numbers before placing a call. With this feature, the first number is sent in digital form to the cell site. Then up to four other numbers can be sent with DTMF signaling by simply pressing **SEND** for each additional number.

- Note:
- (1) Each number to be linked may be recalled from memory or entered by keypad.
 - (2) Each number to be linked should be within 16 digits including linking mark "=" at the end.
 - (3) Linked number can be stored in the memory. However, number of more than 16 digits should be stored into memory address 91 through 99.

Example: To access the alternate long distance service using a secret number, you should call your long distance service office first, and enter your ID number, then the phone number to be placed.

1. Recall the phone number of the long distance service office.
Press **RCL**, then enter the memory address (01 through 99).

1234567890
7463479

2. Press **ENC**, then key *****.
Linking Mark "=" will be added at the end of the number and **Link 1** will appear.

Link 1
1234567890
7463479=

3. Recall your ID number stored with secret attribution.

- 3-1. Enter the three-digit security code.
Press keys **1**, **2**, **3**.

Link 2
1234567890
123

Note: When you recall the ID number stored without the secret attribution, omit the step 3-1 and proceed to next step 3-2.

- 3-2. Recall the secret memory (ID number).
Press **RCL**, key **4** then **1**.

1234567890
6714852

4. Press **ENC**, then key *****.

Link 2
1234567890
6714852=

5. Recall or dial the phone number to be called.
Press **RCL**, then enter the memory address (01 through 99) to recall the phone number to be called.

1234567890
1234567890

6. Press **SEND**. The **INUSE** indicator will light as the call is placed. **Link 1** will appear on the readout.

Link 1
1234567890
7463479=

7. After you received an answer from the long distance service office, press **SEND** again. The DTMF signal will be placed and the DTMF tone of your ID number can be monitored through the speaker. **Link 2** will appear on the readout.

8. If your ID number is accepted, the long distance service office will answer again, so press **SEND**. Then the long distance call will be placed and the DTMF tone can be monitored through the speaker. **Link 3** will appear on the readout.

Note: The number linked in steps 1 through 5 can also be stored in secret memory as stated in the "Secret Memory".

1. When a set of linked numbers which includes a secret number has been stored in memory address 91 through 99, enter the three-digit security code, press **RCL**, memory address (91 through 99), and then **SEND** to place the call. **Link 1** will appear on the readout, and the first linked number will be called as shown in step 6 above. If the secret number is not included in the linked number, you need not enter the three-digit security code in the above operation.
2. To complete the call, continue operations as shown in the steps 7 and 8.

SCRATCH-PAD DIALING

This feature permits you to enter a number to be redialed (or store a number in memory) while engaged in a conversation.

SCRATCH-PAD DIALING WITHOUT KEYING TONES

This feature permits you to activate scratch-pad memory without annoying key tones over the circuit.

1. Press **ENC**, then key **9**, then enter a phone number. **Tone** will be displayed for 5 seconds. The Microphone circuit will remain active, but the tones will not be heard.
2. If necessary, press **STO**, then enter the memory address.
3. To exit the Scratch-pad Mode, press **ENC**, then key **9** again.

CALL TIME DISPLAY

This feature automatically records the elapsed time per conversation. The talk time of the last call, cumulative talk time, and the number of calls can be displayed on the readout.

The timers can also be cleared if necessary.

With beep tones you can be notified of the approximate talk time (NAM Option) in approximately 60 seconds increments.

To Display the Talk Time of the Last Call

1. Press **RCL**, key ***** then **1**.
The talk time of the last call will be displayed on the readout for 5 seconds.
While in a conversation, the talk time of a call in progress will be displayed, and updated each second. The display format is as follows.
0tm25 ... 1 min. and 25 sec.

To Display the Cumulative Talk Time

1. Press **RCL**, key ***** then **2**.
The cumulative talk time will be displayed on the readout in minute format for 5 seconds.
18m ...18 min.

To Display the Number of Calls

1. Press **RCL**, key ***** then **3**.
The number of calls will be displayed on the readout for 5 seconds. The display format is as follows.
86c ...Received or placed 86 calls.

To Clear the Timer

1. Press **CLR**, then enter the three-digit security code.
2. Press **STO**, key ***** then **1**.
The timers will be cleared, and the count for the cumulative talk time and the number of calls will start from zero.

One Minute Beep (NAM Option)

During conversation, you can be notified of the approximate talk time by tones for the first five minutes. (a short monotone signal will sound every minute and a double beep tone will be heard after approximately 5 minutes.)

A/B SYSTEM SELECTION

This feature permits you to select the system you need to use. The system that you are registered with is the preferred system, and your home system.

1. Standard Mode

When you turn the unit on, the unit remembers the last position of the A/B system selected, and will start to scan the radio frequency channels of that selection.

If you want to confirm the current mode, press **FNC**, key **0** then **4**. Status indicator shows the current mode. To return the unit to the standard mode, press **FNC**, key **0** then **0** again. Status indicator shows **STD**. The unit will scan the preferred system channels. If unable to find an acceptable preferred channel, the unit switches to scan the non-preferred channels.

2. Preferred System Only Mode

Press **FNC**, key **0** then **1**. Status indicator shows **PFF**. The unit will scan the preferred system only and prevents switching over to the non-preferred system.

3. Non-preferred System Only Mode

Press **FNC**, key **0** then **3**. Status indicator shows **N-PRE**. The unit will scan the non-preferred system only.

4. Home Only Mode

Press **FNC**, key **0** then **2**. Status indicator shows **Home**. You can place or receive calls only within your home area.

Note: (1) The **HOAM** indicator lights as follows.

Lights continuously;

When the unit is in the preferred system in another city.

Flashes;

When the unit is in the non-preferred system.

(2) The **NOSVC** indicator flashes when the unit is requesting service but not in the requested service area.

SYSTEM INHIBIT (NAM OPTION)

This feature permits you to inhibit (by NAM Option) cellular systems, or Roam Systems you do not want to use, even when in that service area. The **NOSVC** indicator flashes, if your A/B switch is selected to any system that is inhibited.

MULTIPLE CITY REGISTRATION

Some cellular users find it beneficial to register their phone in multiple cities, rather than rely on "roam". The multiple city registration feature permits you to reprogram from the telephone unit, the different phone numbers for the cities in which you are registered. Each programmed phone number will be designated as your home system.

Press **CLR**, and enter the new system ID number (5 digits) followed by the corresponding phone number (10 digits). Please include your area code. You must register your unit with the carrier in order to get both the system ID number and your phone number.

Press **FNC** then key **6**. Your new phone number will be displayed on the readout. (Holding down **6**, to display your new system ID number.)

Note: (1) System ID number and phone number can not be programmed during a call.

(2) Calls are placed or received using only the programmed phone number, in use at the time of call.

RADIO FREQUENCY (RF) CHANNEL INDICATOR

If necessary, you can see the RF channel status in which your unit is operating.

1. Press **RCL**, key **4** then **4**.

The RF channel number, RSSI, SAT color code, and transmitting power level will be displayed on the readout. The display format is as follows:

```

      C123
R187 S0 P2
  
```

C123.... RF channel number
 R187.... RSSI value
 S0.... SAT color code
 P2.... Transmitting power level

2. The display will remain on the readout until you manually reset it by pressing any key.

LAST RESCAN SID INDICATOR

This feature permits you to view the last rescan SID accessed by your phone.

Press **RCL**, key **9** then **9**.

The last rescan SID is displayed on the readout for 5sec. The display format is as follows:

```

      SID
00020
  
```

If the **NOSVC** indicator is on, the display will show

```

- - - -
  
```

FUNCTION REVIEW

This feature shows you which numbered keys to use for different FUNC/RCL key functions.

To review the function menu:

Press **FNC** for about one second.

Scroll the menu up or down, using the **↑** or **↓** key respectively.

The display information will appear as follows.

DISPLAY	FUNCTION
[Lock] [FNC 1] Lock
[A.D/T] [FNC 2] Automatic Data Transmission ⁽⁴⁾
[A.Ans] [FNC 5] Automatic Answering
[Mute] [FNC 8] Mute
[Tone] [FNC 9] DTMF Tone Mute
[Absys] [FNC 0 0-4] A/B System Selection
[Timer] [RCL * 1-3] Call Timer
[RF CH] [RCL * 4] RF Channel Indication
[Light] [RCL * 5] Backlighting Control
[Alert] [RCL * 6] Alert Volume Control
[Silen] [RCL * 7] Silent Incoming Calls
[Batt.] [RCL * 8] Battery Level Indication
[R.SID] [RCL * 9] Last Rescan SID Indication
[<ID>] [RCL * *] Present SIDH+Phone Number
[Alpha] [FNC ALPH] Alpha Mode
[Data] [FNC SEND] Data Transmission ⁽⁴⁾
[Secrt] [FNC STO N] Secret Memory
[Restr] [XYZ FNC #7]] Call Restricted Mode
[ID] [<ID> FNC 6]] Multiple City Registration

Note: (1) N = Repertory Memory Address
(01 through 99)

(2) XYZ = Three-digit Security Code

(3) <ID> = System ID number + Own
Phone Number

(4) These features are available only when the unit is connected with a Car Kit (option).

IMPORTANT SAFETY INFORMATION

Please read and follow these cautions carefully. **TURN OFF** your unit in an explosive atmosphere (near a fuel pump, blasting area, etc.).

DO NOT dial when your unit is moving in states where this action is illegal (this is not a prudent practice, even where it is legal).

DO NOT permit untrained personnel to operate the unit.

WARNING

The following offences can punished by fine, imprisonment, or both:

- Using obscene, indecent, or profane language.
- Using the unit to give off false distress calls.
- Wiretapping or otherwise intercepting a telephone call, unless that person has first obtained the consent of the parties participating in the call.
- Making anonymous calls to annoy, harass, or molest other people.
- Charging to an account without authorization to avoid payment for service.
- Refusing to yield a party line when informed that it is needed for an emergency call (It is also unlawful to take over a party line by stating falsely that it is needed for an emergency).