

Emerson[®]

MICRO AUDIO SYSTEM
with CD, CD-R/RW PLAYER
and DIGITAL TUNER



OWNER'S MANUAL

ES13

Visit our web site at www.emersonradio.com





WARNING

TO PREVENT FIRE OR SHOCK HAZARD, DO NOT USE THIS PLUG WITH AN EXTENSION CORD, RECEPTACLE OR OTHER OUTLET UNLESS THE BLADES CAN BE FULLY INSERTED TO PREVENT BLADE EXPOSURE. TO PREVENT FIRE OR SHOCK HAZARD, DO NOT EXPOSE THIS APPLIANCE TO RAIN OR MOISTURE.



The lightning flash with arrow-head symbol, within an equilateral triangle is intended to alert the user to the presence of uninsulated 'dangerous voltage' within the product's enclosure that may be of sufficient magnitude to constitute a risk of electric shock to persons.

CAUTION

RISK OF ELECTRIC SHOCK
DO NOT OPEN

WARNING: TO REDUCE THE RISK OF ELECTRIC SHOCK DO NOT REMOVE COVER (OR BACK), NO USER SERVICEABLE PARTS INSIDE REFER SERVICING TO QUALIFIED SERVICE PERSONNEL.



The exclamation point within an equilateral triangle is intended to alert the user to the presence of important operating and maintenance (servicing) instructions in the literature accompanying the appliance.

IMPORTANT SAFETY INSTRUCTIONS

- 1.) Read these instructions.
- 2.) Keep these instructions.
- 3.) Heed all warnings.
- 4.) Follow all instructions.
- 5.) Do not use this apparatus near water.
- 6.) Clean only with dry cloth.
- 7.) Do not block any ventilation openings. Install in accordance with the manufacturer's instructions.
- 8.) Do not install near any heat sources such as radiators, heat registers, stoves, or other apparatus (including amplifiers) that produce heat.
- 9.) Do not defeat the safety purpose of the polarized or grounding-type plug. A polarized plug has two blades with one wider than the other. A grounding type plug has two blades and a third grounding prong. The wide blade or the third prong are provided for your safety. If the provided plug does not fit into your outlet, consult an electrician for replacement of the obsolete outlet.
- 10.) Protect the power cord from being walked on or pinched particularly at plugs, convenience receptacles, and the point where they exit from the apparatus.
- 11.) Only use attachments / accessories specified by the manufacturer.
- 12.) Unplug this apparatus during lightning storms or when unused for long periods of time.
- 13.) Refer all servicing to qualified service personnel. Servicing is required when the apparatus has been damaged in any way, such as power-supply cord or plug is damaged, liquid has been spilled or objects have fallen into the apparatus, the apparatus has been exposed to rain or moisture, does not operate normally, or has been dropped.
- 14.) This appliance shall not be exposed to dripping or splashing water and no object filled with liquids such as vases shall be placed on the apparatus.
- 15.) Do not overload wall outlet. Use only power source as indicated.
- 16.) Use replacement parts as specified by the manufacturer.
- 17.) The product may be mounted to a wall only if recommended by the manufacturer.
- 18.) Upon completion of any service or repairs to this product, ask the service technician to perform safety checks.

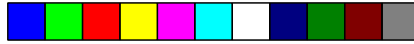

Thank you for purchasing this Emerson audio product. The Emerson brand is your assurance of quality, performance and value, Our engineers have included many useful and convenient features in this product. Please be sure to read this Owner's Manual completely to make sure you are getting the maximum benefit from each feature.

This product was manufactured using the highest quality components and standards of workmanship. It was tested by Emerson inspectors and found to be in perfect working order before it left our factory. However, there is always the chance that some problem may occur because of rough handling during shipment to the retail store or to the final consumer.

If, after reading this Manual, you experience any problems with the operation of this product, please refer to the instructions for obtaining service at the end of this Manual. Emerson and Emerson retailers are committed to your satisfaction.

Once again, thanks for purchasing this Emerson audio product.

For future reference, record the serial number in the space provided.

Model No: ES13

Serial Number: _____

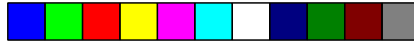

IMPORTANT NOTES

- Avoid installing this unit in places exposed to direct sunlight or close to heat radiating appliances such as electric heaters, on top of other stereo equipment that radiates heat, places lacking ventilation or dusty areas, places subject to constant vibration and/or humid or moist areas.
- Do not attempt to clean this unit with chemical solvents as this might damage the finish. Use a clean dry cloth.
- Operate controls and switches as described in the manual.
- Before turning on the power, make certain that the connecting cords and power cord are properly installed.
- Store your CDs in a cool area to avoid damage from heat.
- When moving the set, be sure to first disconnect the power cord and remove cords connected to other equipment.

CLASS 1 LASER PRODUCT

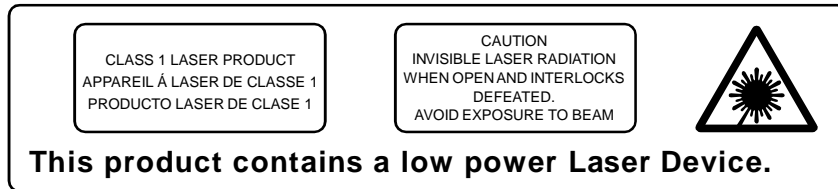

FCC INFORMATION

This equipment has been tested and found to comply with the limits for a Class B digital device, pursuant to Part 15 of the FCC Rules. These limits are designed to provide reasonable protection against harmful interference in a residential installation. This equipment generates, uses, and can radiate radio frequency energy and, if not installed and used in accordance with the instructions, may cause harmful interference to radio communications. However, there is no guarantee that interference will not occur in a particular installation. If this equipment does cause harmful interference to radio or television reception, which can be determined by turning the equipment off and on, the user is encouraged to try to correct the interference by one or more of the following measures:

- Reorient or relocate the receiving antenna.
- Increase the separation between the equipment and receiver.
- Connect the equipment into an outlet on a circuit different from that to which the receiver is connected.
- Consult the dealer or an experienced radio/TV technician for help.

This device complies with Part 15 of the FCC Rules. Operation is subject to the following two conditions:

- (1) This device may not cause harmful interference, and
- (2) This device must accept any interference received, including interference that may cause undesired operation.

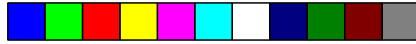

PREPARATION FOR USE

UNPACKING AND SET-UP

- Carefully remove the unit from the carton and remove all packing material from the unit.
- Remove any labels or stickers which may be on the front or top of the set, but do not remove any labels from the back or bottom.
- We suggest that you retain the original carton and packing materials in case it ever becomes necessary to return your unit for service. This is the only sure way to protect the unit from damage in transit.
- If you do dispose of the carton and packing materials, please do so properly. Emerson cares about our environment.

POWER SOURCE

This system is designed to operate on 120V 60Hz AC house current . Connecting this system to any other power supply could result in damage to the unit which is not covered by your warranty. You will note that this system is equipped with a polarized AC power plug having one blade wider than the other. This is a safety feature. If this plug does not fit into your existing AC outlet, do not try to defeat this safety feature by filing the wide blade to make it fit into your outlet. If this plug will not fit into your outlet, you probably have an out-dated non-polarized AC outlet. You should have your outlet changed by a qualified licensed electrician.

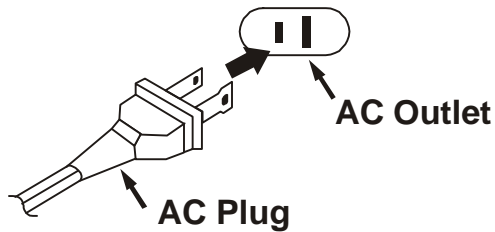

AC OPERATION

- 1.) Unwind the AC Power Cord completely.
- 2.) Insert the plug into any convenient 120V 60Hz AC outlet.

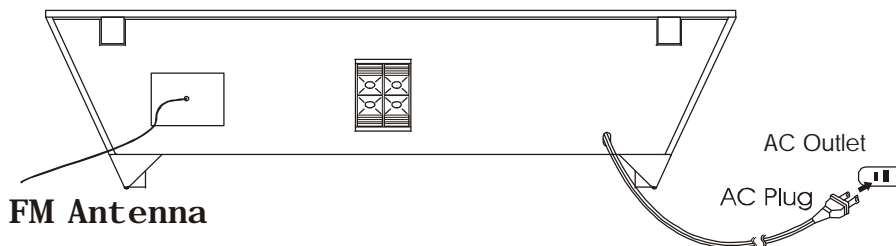

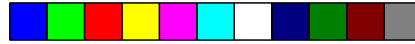

LOCATION OF CONTROLS AND INDICATORS

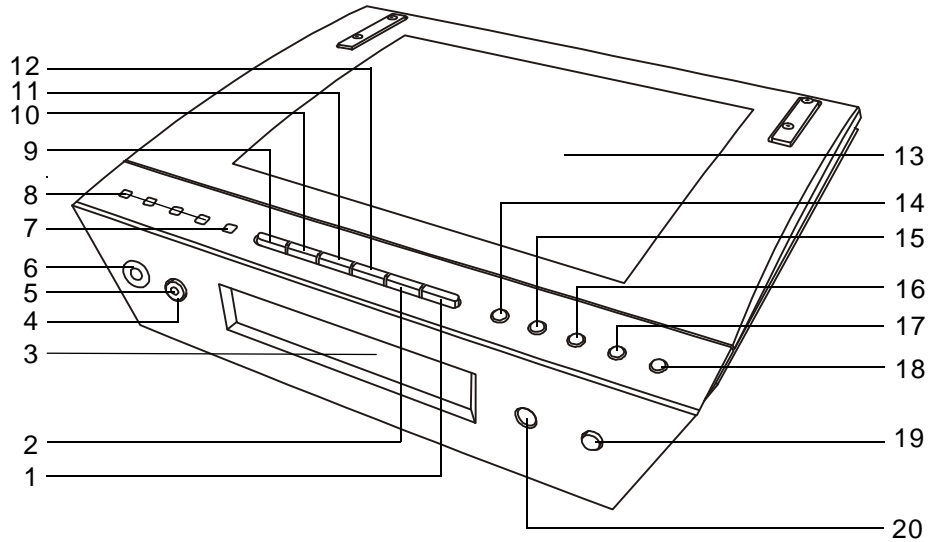

- 1.) PLAY/PAUSE ►► Button.
- 2.) STOP ■ Button.
- 3.) Multi Function LCD Display.
- 4.) POWER On/Off Button.
- 5.) STANDBY LED Indicator.
- 6.) PHONES Jack.
- 7.) BASS BOOST (Lighted) Button.
- 8.) Preset EQ (Lighted) Buttons.
(POP/ROCK/CLASSIC/FLAT)
- 9.) CD Button.
- 10.) TUNER/BAND Button.
- 11.) SKIP SEARCH ◀◀ /
TUNING (SET) ∨ Button.

- 12.) SKIP SEARCH ►► /
TUNING (SET) ^ Button.
- 13.) CD Door.
- 14.) VOLUME ∨ Button.
- 15.) VOLUME ^ Button.
- 16.) PRESET UP/RANDOM/INTRO
Button.
- 17.) TIME SET/MEMORY Button.
- 18.) FM MODE/REPEAT Button.
- 19.) CD DOOR OPEN/CLOSE Button.
- 20.) Remote Control Sensor.

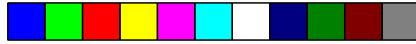

REMOTE CONTROL

- 1.) VOLUME \vee / \wedge Buttons.
- 2.) TIMER SET Button.
- 3.) SLEEP Button.
- 4.) PRESET \vee Buttons.
- 5.) SNOOZE Button.
- 6.) Stop \blacksquare Button.
- 7.) TUNING (SET) \lll / \ggg
- CD SKIP SEARCH \lll / \ggg Buttons.
- 8.) CD Button.
- 9.) OPEN/CLOSE Button.
- 10.) 0-9 Number Buttons.
- 11.) MUTE Button.
- 12.) STANDBY ON/OFF Button.
- 13.) TUNER/BAND Button.
- 14.) FM MODE/REPEAT Button.
- 15.) Play/Pause $\blacktriangleright\parallel$ Button.
- 16.) MEMORY Button.
- 17.) PRESET \wedge /INTRO Button.
- 18.) RANDOM Button.
- 19.) TIMER OFF Button.

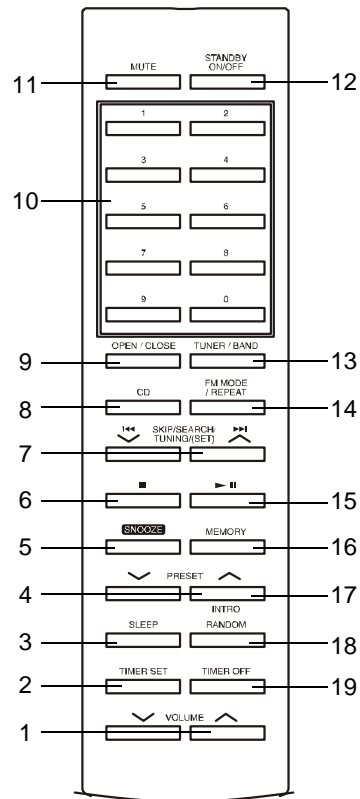

BATTERY INSTALLATION

Insert 2 pcs 'AA' size (Alkaline) batteries (not included) into the battery compartment of the remote controller. Be sure to observe the polarity markings which are engraved inside the battery compartment, then close the cover.

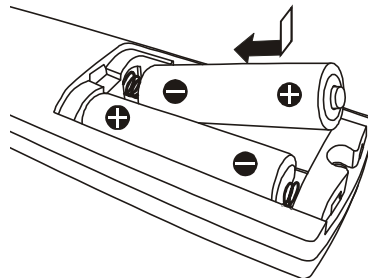
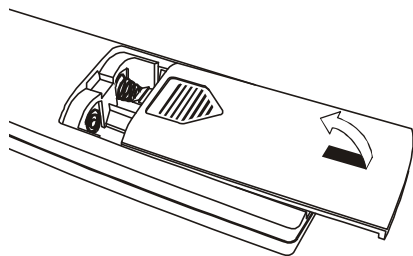

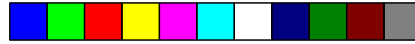

BATTERY REPLACEMENT

When the batteries become too weak, the operating distance of the remote controller is greatly reduced and you will need to replace the batteries.

NOTES:

- To maintain the accuracy and long life of the transmitter, do not press two or more buttons simultaneously.
- If the remote control is not to be used for a long time, remove the batteries to prevent possible damage through leaking batteries.
- Do not mix different types of batteries, or old batteries with new ones.

USING THE REMOTE CONTROLLER CORRECTLY

- Point the remote controller at the Remote Sensor.
- The functions of the buttons on the remote control are the same as the corresponding controls on the main unit.
- When there is a strong ambient light source, the performance of the infrared Remote Sensor may be degraded, causing unreliable operation.
- The maximum effective distance for remote control operation is about 15 feet.

BATTERY PRECAUTIONS

Follow these precautions when using batteries in this device:

1. Use only the size and type of batteries specified.
2. Be sure to follow the correct polarity when installing the batteries as indicated in the battery compartment. Reversed batteries may cause damage to the device.
3. Do not mix different types of batteries together (e.g. Alkaline and Carbon-Zinc) or old batteries with fresh ones.
4. If the device is not to be used for a long period of time, remove the batteries to prevent damage or injury from possible battery leakage.
5. Do not try to recharge batteries not intended to be recharged; they can overheat and rupture (Follow battery manufacturer's directions.)

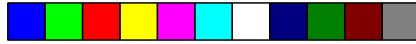

OPERATING INSTRUCTIONS

SPEAKER CONNECTION

Connect each speaker to the corresponding speaker terminals on the back panel of the main unit. Make sure that the left (black) speaker wire is connected to the left (L) black speaker clip and the right (red) speaker wire is connected to the right (red) speaker clip.

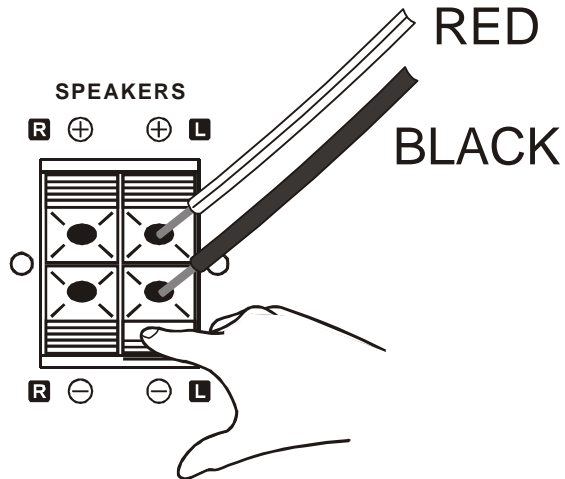
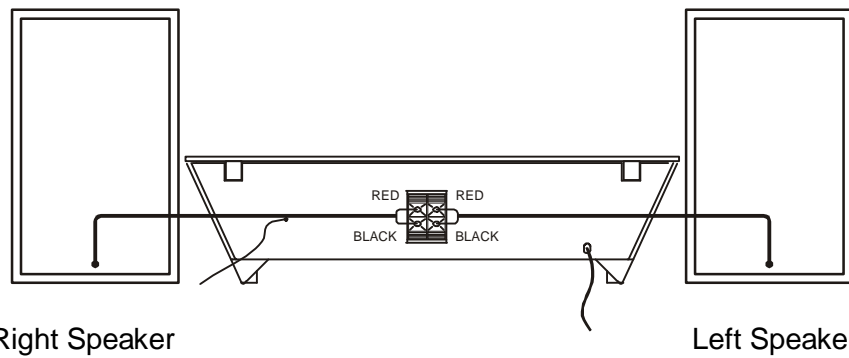

SETTING THE CLOCK

The clock should be set while the system is in the Standby mode (Power 'Off').

- 1.) Press and hold the TIME SET/MEMORY button on the top panel for at least two seconds. The hour digits and the AM/PM indicator begin to flash.



- 2.) Press the TUNING (SET) ^ or v buttons on the top panel or on the remote control to adjust the clock to the correct hour, AM or PM.

- 3.) Press the TIME SET/MEMORY button once more. The minute digits begin to flash.



- 4.) Press the TUNING (SET) ^ or v buttons on the top panel or on the remote control to adjust the clock display to the correct minutes.

- 5.) Press the TIME SET/MEMORY button once more. The display will show "12 H" meaning that the time will be displayed in '12 hour format' (6 PM = 6:00). If you prefer '24 hour format' (6 PM = 18:00), press either the TUNING (SET) ^ or v buttons on the top panel or on the remote control to switch between "12H" and "24H" time formats.

- 6.) Press the TIME SET/MEMORY button once more. The time display returns and the clock begins to run.

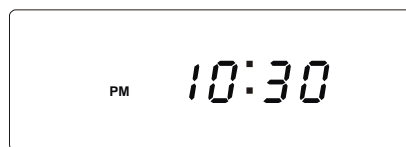

The time will appear on the display whenever the system is in the Standby (Power 'Off') mode. The STANDBY LED lights up.

Note: If the AC power is disconnected for an extended period, the time memory will be lost and the clock will have to be reset when power is restored.

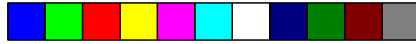

TONE CONTROLS

Preset Equalizer

This system includes a 4 mode preset electronic equalizer that allows you to tailor the sound output for the most popular types of music. The settings are POP, ROCK, CLASSIC, and FLAT (Equalizer Off). Press the appropriate button on the top panel to select the desired setting. The button lights to confirm your selection.

Note: *The Equalizer controls are only found on the top panel. There are no EQ controls on the remote control.*

BASS BOOST

The Bass Boost control is designed to provide additional bass response, especially at lower volume levels where the bass tends to disappear. Press the BASS BOOST button on the top panel to turn the Bass Boost 'On' or 'Off'. The button lights when Bass Boost is on.

Note: *If you have the EQ set to Rock, the Bass Boost 'On', and your are listening to loud music with heavy bass, you may experience some distortion. If this occurs, lower the volume, turn the Bass Boost 'Off', or set the EQ to the FLAT position.*



LISTENING TO THE RADIO

- 1.) Press the POWER/STANDBY button on the top panel or on the remote control to turn the system 'On'. The STANDBY indicator goes 'Off' and the main display comes 'On'.
- 2.) Press the TUNER/BAND button on the top panel or remote control to select the Tuner function, and press again to switch between AM and FM bands. The display will show an AM or FM frequency.

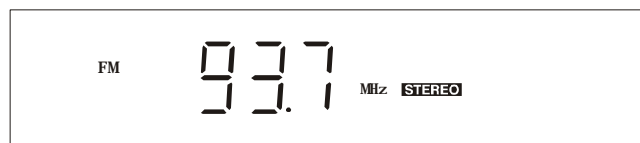

- 3.) Press the TUNING (SET) \wedge or \vee buttons on the top panel or on the remote control to tune to the desired station.
 - **Manual Tuning** – repeatedly press the TUNING (SET) \wedge or \vee buttons until the display shows the frequency of the desired station.
Note: Use this method to tune in weaker stations.
 - **Automatic Tuning** – Press and hold the TUNING (SET) \wedge or \vee buttons until the display begins to move, then release the buttons. The tuner will search up or down for the first strong station and stop on that station. Repeat until the tuner stops on the desired station.
- 4.) Press the VOLUME \wedge or \vee buttons on the top panel or on the remote control to adjust the volume.
- 5.) Adjust the Equalizer and BASS BOOST controls as desired.
- 6.) When you are finished listening press the POWER/STANDBY button on the front panel or on the remote control to turn the system 'Off'. The main display goes 'Off' and the STANDBY indicator comes 'On' again.



ANTENNA INFORMATION

FM

The leadwire antenna should be extended to its full length for optimum FM reception.

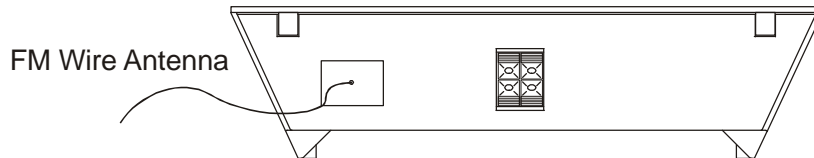

AM

The AM antenna is inside the main unit. If AM reception is weak try turning the main unit slightly until the AM reception improves. In the worst case you may have to move the entire unit to another location.

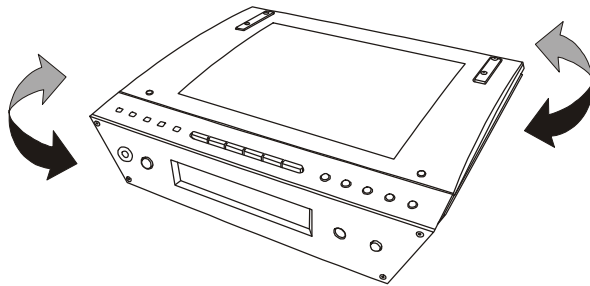

MONO/STEREO MODE SWITCH

If you tune to an FM Stereo station the FM **STEREO** indicator will appear in the display. However if the FM Stereo reception is unsatisfactory press the FM MODE/ REPEAT button on the top panel or on the remote control. The MONO indicator will appear in the display and reception should improve, although the sound is no longer in stereo.

In most cases leave the FM MODE selector set to STEREO.



PRESETTING STATIONS IN THE TUNER MEMORY

You can store up to 20 of your favorite stations, in any combination of AM and FM, in the tuner memory for immediate recall. For your convenience use the remote control to perform this operation.

- 1.) Tune to the first station you wish to memorize by either the Manual or Automatic tuning method. Example: FM 103.5 MHz
- 2.) Press the MEMORY button on the remote control. The Memory indicator will begin flashing in the display.

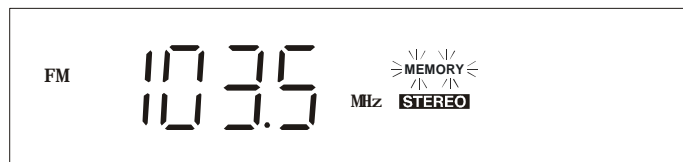

- 3.) Press either the PRESET \wedge or \vee buttons on the remote control to select a desired memory number. Example: Channel Memory 7.



- 4.) Press the MEMORY button on the remote control once more to enter the station into the selected memory number.
- 5.) Repeat this procedure, selecting a different preset number each time, until you have entered up to 20 stations in the tuner memory.



RECALLING PRESET STATIONS

- In Tuner mode, press either the PRESET \wedge or \vee buttons on the remote control to locate the desired station. You may also press the PRESET UP/RANDOM/INTRO button on the top panel to scroll upward through the presets in numerical order.
- In Tuner mode to select a preset directly press the appropriate number buttons on the remote control.

Note: When you press numbers 1 through 9 the tuner will pause for a moment waiting for you to enter a second number. After a few seconds it will tune to the number you entered. To select presets 11 through 20 simply press the appropriate number buttons on the remote in the correct sequence.

CHANGING PRESET STATIONS

Tune to the new station you want to memorize. Press the MEMORY button, then press the PRESET \wedge or \vee buttons to select the memory number that you want to change. When the memory number appears on the display press the MEMORY button again. The new station will be memorized and the old station will be deleted from the memory.



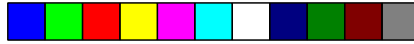

PLAYING COMPACT DISCS

IMPORTANT: This player will play normal CDs plus CD-R and CD-RW discs. However the playability of CD-R and CD-RW discs is determined by the software that was used to create the discs, and the quality of the blank media used for recording. 100% playability cannot be guaranteed. This is not an indication of a problem with your system.

- 1.) Press the POWER/STANDBY button on the front panel or remote control to turn the system 'On'.
- 2.) Press the CD function button on the front panel or remote control to select CD mode.
- 3.) Press the CD door OPEN/CLOSE button on the front panel or remote to open the CD door. If you have not already done so remove and discard the CD transit protection card.
- 4.) Place your CD on the center spindle with printed label side up. Gently press down around the center hole to make sure the disc is properly seated on the spindle. Close the CD door.
- 5.) The disc will begin to spin, the display will show the total tracks and playing time and then playback begins on track 1.



- 6.) Adjust the VOLUME, EQUALIZER, and BASS BOOST controls as desired.
- 7.) After the last track has played the disc stops and the display again shows the total tracks and playing time. You may also stop playback at anytime by pressing the STOP ■ button on the top panel or remote control.
- 8.) When the disc has stopped completely press the CD door OPEN/CLOSE button on the front panel or remote control to open the door. Remove your disc, close the door, and shut the system 'Off'.



PAUSE CONTROL

To pause temporarily during playback press the PLAY/PAUSE ►|| button again. The sound stops and the time display flashes but the disc continues to spin. Press the PLAY/PAUSE ►|| button once more to cancel pause and resume normal playback.

SKIP/SEARCH CONTROLS

During playback press the SKIP/SEARCH ◀◀ or ▶▶ controls repeatedly to skip to higher or lower numbered tracks.

During playback press and hold the SKIP/SEARCH ◀◀ or ▶▶ controls to search forward or backward at high speed to locate a particular passage within a track. When you hear the desired passage release the buttons and normal playback will resume from that point.

REPEAT PLAYBACK

You can repeat a single track or the entire disc automatically.

All Tracks Repeat – Start playback and press the FM MODE/REPEAT button on the top panel or on the remote control one time. The Repeat indicator appears in the display. The entire disc will be repeated continuously.



One Track Repeat – Start playback and skip to the track you wish to repeat. Press the FM MODE/REPEAT button on the top panel or remote control twice. The Repeat indicator flashes in the display. The selected track will be repeated continuously.





To cancel Repeat Playback press the FM MODE/REPEAT button until the Repeat indicator no longer appears in the display. Repeat Playback will also be canceled if you switch to Tuner mode, open the CD door, or switch the power 'Off'.

RANDOM PLAYBACK

Use the Random Playback feature to play all of the tracks on the disc in a random order.

While in Stop mode press the RANDOM button on the remote control, or press the PRESET UP/RANDOM/INTRO button on the top panel once. The RANDOM indicator appears in the display. Press the PLAY/PAUSE ►► button to begin Random playback. After all the tracks have been played in random order the player stops and the display shows the total tracks and playing time.



To cancel Random Playback press the RANDOM button on the remote control, or press the PRESET UP/RANDOM/INTRO button on the top panel until the RANDOM indicator no longer appears in the display. Random Playback will also be canceled if you switch to Tuner mode, open the CD door or switch the power 'Off'.

INTRO SCAN PLAYBACK

Intro Scan playback plays only the first 10 seconds of each track on the disc. This feature is useful if you are trying to locate a particular song but you do not remember the title.

While in Stop mode press the PRESET UP/RANDOM/INTRO button on the top panel twice, or press the PRESET ^ /INTRO button the remote control. The Intro indicator appears in the display. Press the PLAY/PAUSE ►► button to begin Intro playback. After the first 10 seconds of all tracks have been played the player stops and the display shows the total tracks and playing time.





To cancel Intro Playback at any time press the PRESET \wedge /INTRO button on the top panel or the remote control until the Intro indicator no longer appears in the display. Intro Playback will also be canceled if you switch to Tuner mode, open the CD door or switch the power 'Off'.

PROGRAMMED PLAYBACK

You can program the player to play only the tracks you want to hear in the specific order that you want them to play. The maximum number of tracks that can be programmed is 20. You may program tracks to play more than once if desired.

Note: You cannot program the player while a disc is playing. If a disc is playing press the STOP \blacksquare button to stop playback and then follow the steps below.

- 1.) While in Stop mode press the TIME SET/MEMORY button on the top panel, or the MEMORY button on the remote control. The MEMORY indicator flashes and the program number "Pr 1" appears in the display.

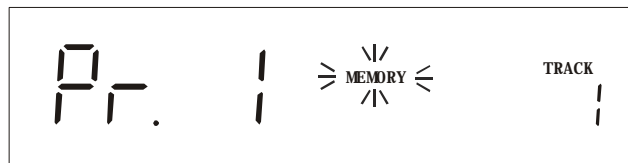

- 2.) Press the $\blacktriangleright\blacktriangleright$ / $\blacktriangleleft\blacktriangleleft$ SKIPS EARCH or 9 buttons to select the first track that you want to program. Example: Track number 7.

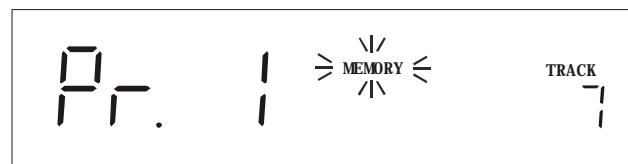

- 3.) Press the TIME SET/MEMORY button on the top panel, or the MEMORY button on the remote control again to enter the selected track in program memory number 1. The MEMORY indicator stops flashing.

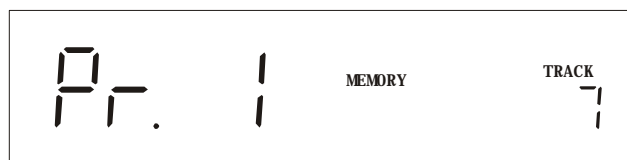



- 4.) Press the ►► / ◄◄ SKIP SEARCH or 9 buttons to select the second track that you want to program. The program number display advances to “Pr 2”.

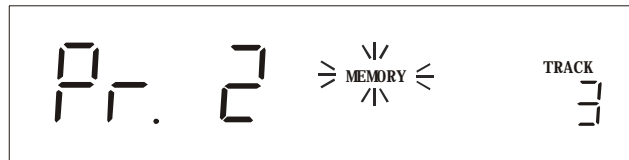

- 5.) Repeat steps 3 and 4, selecting a different track each time, until you have entered up to 20 tracks in the program memory.
- 6.) Press the PLAY/PAUSE ►|| button to begin programmed playback. The Program indicator stops flashing and remains in the display. The tracks you selected will play in the order in which they were programmed.



- 7.) After the last programmed track has played the player stops and the display shows as below illustration.



- 8.) Press PLAY/PAUSE ►|| button to repeat the programmed playback.
- 9.) To cancel the programmed track, press the STOP ■ button while in Stop mode. The display shows the total tracks and playing time on the disc.

Note: You can use the Repeat and Programmed Play features together to repeat a programmed sequence of tracks continuously. After you enter the desired tracks in the program memory and begin playback, press the FM MODE/REPEAT button once to select All Tracks Repeat. The program will be repeated continuously.



WAKE UP TIMER OPERATION

This system includes a wake-up timer function that will automatically turn the unit 'On' to the radio or CD player..

Setting the Wake Up Time

Note: The system must be in the Standby (Power 'Off') mode to set the wake up timer.

- 1.) Press the TIME SET/MEMORY button on the top panel or TIME SET button on remote control once. The Timer indicator (L) and the hour digits begin flashing in the display.

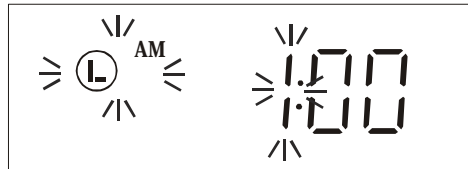

- 2.) Press the TUNING/(SET) \vee or \wedge buttons on the top panel or remote control to adjust the display to the desired wake up hour, AM or PM.

- 3.) Press the TIME SET/MEMORY button on the top panel or TIME SET button on remote control once more. The minute digits begin to flash.

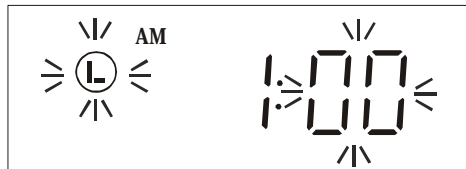

- 4.) Press the TUNING/(SET) \vee or \wedge buttons on the top panel or remote control to set the minutes.

- 5.) Press the TIME SET/MEMORY button on the top panel or TIME SET button on remote control once more. The display returns to the current time but the Timer indicator (L) remains 'On', indicating that the Wake Up Timer is set.

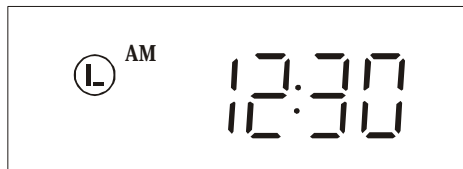



TO WAKE TO THE RADIO

Turn the system 'On', press TUNER/BAND button to select AM or FM mode as desired. Tune to the desired wake up station and adjust the volume to the desired level to wake you up. Then switch the system back to the Standby (Power 'Off') mode.

At the selected wake up time the system will turn on automatically. The Timer indicator (L) flashes in the display. To shut the system 'Off', press the STANDBY button on the front panel or on the remote control. The system shuts 'Off' and the alarm resets itself for the following day. To cancel the Wake Up Timer press the TIMER OFF button on the remote control. The Timer indicator disappears from the display.

TO WAKE TO THE CD PLAYER

Turn the system 'On', select CD mode, and load the desired CD. Start playback and adjust the volume to the desired level to wake you up. Stop playback and then switch the system back to the Standby (Power 'Off') mode.

At the selected wake up time the system will turn on automatically and playback will continue until the end of the disc. The Timer indicator (L) flashes in the display. To shut the system 'Off', press the STANDBY button on the front panel or on the remote control. The system shuts 'Off' and the alarm resets itself for the following day. To cancel the Wake Up Timer press the TIMER OFF button on the remote control. The Timer indicator disappears from the display.

SNOOZE FUNCTION

After the Wake Up Timer turns the system 'On' you can press the SNOOZE button on the remote control for an extra 9 minutes sleep. The system turns 'Off' and the display shows normal time. The Timer indicator (L) flashes during Snooze operation. After 9 minutes the alarm will turn 'On' again.



SLEEP TO MUSIC TIMER

Press the SLEEP button on the remote control to start the Sleep To Music Timer. The SLEEP indicator appears in the display. The system turns on and will play for 90 minutes before shutting off automatically. To reduce the amount of Sleep Time, continue pressing the SLEEP button. The time will decrease in 15 minute decrements: 90 > 75 > 60 > 45 > 30 > 15. When the time counts down to "00" the system shuts off automatically.



To shut the system off before the Sleep Timer counts down to "00" , press the STANDBY button on the front panel or on the remote control.

STEREO HEADPHONE JACK

Connect the stereo headphones to the 3.5mm PHONES jack located at front panel for private listening. When the headphones are connected, the sound from the speakers will automatically cut off. Before putting the headphones on your head, reduce the volume to a low level. Then put the headphones on and gradually increase the volume to a comfortable listening level.

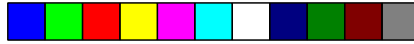

CARE AND MAINTENANCE

COMPACT DISC CARE

- To remove a disc from its storage case, press down on the centre of the case and lift the disc out, holding it carefully by the edges.

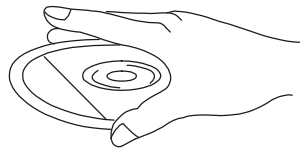
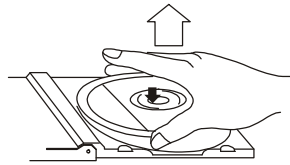

- Fingerprints and dust should be carefully wiped off the disc's recorded surface with a soft cloth. Unlike conventional records, compact discs have no grooves to collect dust and microscopic debris, so gently wiping with a soft cloth should remove most particles. Wipe in a straight line from the inside to the outside of the disc. Small dust particles and light stains will have absolutely no effect on reproduction quality.
- Clean the disc periodically with a soft, lint-free, dry cloth. Never use detergents or abrasive cleaners to clean the disc. If necessary, use a CD cleaning kit.
- Never write on or affix labels to the surface of compact discs.

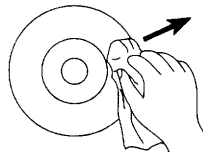
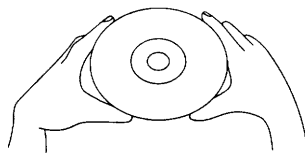

CARE OF THE CABINETS

- If the cabinets become dusty wipe them with a soft dry dust cloth. Do not use any wax or polish sprays on the cabinets.
- If the front panel becomes dirty or smudged with fingerprints it may be cleaned with a soft cloth slightly dampened with a mild soap and water solution. Never use abrasive cloths or polishes as these will mar the finish of your unit.

CAUTION:

Never allow any water or other liquids to get inside the unit while cleaning.

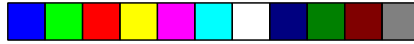

TROUBLESHOOTING GUIDE

Should this unit exhibit a problem, check the following before seeking service.

| Symptom | Possible Cause | Solution |
|--|---|---|
| Radio | | |
| Noise or sound distorted on AM or FM broadcasts. | Station not tuned properly for AM or FM. | Retune the AM or FM broadcast station. |
| | FM: Wire antenna is not extended. | Extend FM Wire antenna. |
| | AM: The Loop antenna is not positioned correctly. | Reposition the Ant. until best reception is obtained. |
| FM STEREO indicator does not light. | FM station is mono or station signal is weak. | Extend FM Wire antenna. Try other strong stations. |
| AM or FM, no sound. | Function is not set to Tuner. | Press TUNER/BAND button to select AM or FM function. |
| | Volume at minimum. | Increase Volume. |
| Compact Disc Player | | |
| CD Player will not play. | Function is not set to CD. | Press CD button to select CD function. |
| | CD is not installed or installed incorrectly. | Insert CD with label side up. |
| CD skips while playing. | Disc is dirty or scratched. | Wipe disc with cloth or use another disc. |



TO FIND THE LOCATION AND PHONE NUMBER OF YOUR NEAREST SERVICE CENTER PERMITTED TO PERFORM WARRANTY...

CALL TOLL FREE: 1-800-695-0098

FOR ADDITIONAL SET-UP OR OPERATING ASSISTANCE
PLEASE CALL:
1-800-898-9020

FOR CUSTOMER SERVICE, PLEASE WRITE TO:
Emerson Radio Corp.,
Consumer Affairs Dept.,
1901 Diplomat Drive,
Farmers Branch, TX 75234.

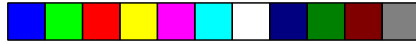

LIMITED WARRANTY

Emerson Radio Corp. warrants manufacturing defects in original material, including original parts and workmanship, under normal use and conditions, for a period of ninety (90) days from the date of original purchase in the U.S. With your dated proof of purchase, we will provide repair service at no charge for labor and parts at an authorized Depot Repair Facility, or replace the product in our discretion. For repair or replacement, pack your unit in a padded box, enclose your check or money order payable to Emerson Radio Corp. in the amount of \$9.00 (not required by California residents) to cover shipping and handling costs, and enclose a copy of your proof of purchase. Send your unit to:

Emerson Radio Corp.
1901 Diplomat Drive.
Farmers Branch, TX 75234.

This warranty does not cover damage from negligence, misuse, abuse, accident, failure to follow operating instructions, commercial use, rental, repairs by an unauthorized facility, or products purchased, used, serviced or damaged outside of the United States.

THIS WARRANTY GIVES YOU SPECIFIC LEGAL RIGHTS, AND YOU MAY ALSO HAVE OTHER RIGHTS WHICH VARY FROM STATE TO STATE.

AU898M



EMERSON RADIO CORP.

EMERSON
Part No. : 16-28??
209-01

Printed in China