

Please read all instructions **BEFORE** assembly and **USE** of product.
KEEP INSTRUCTIONS FOR FUTURE REFERENCE.

baby trend[®]



Model # 1305TW
Infant car seats not included

Double Snap N Go[®]

Instruction Manual

Convenience through innovation and thoughtful design



Double Snap N Go[®]

⚠ WARNING: Please follow all of these instructions to ensure the safety of your children. Keep these instructions for future reference.

⚠ WARNING: Failure to follow these instructions could result in serious injury or death. Avoid serious injury from falling or sliding out. Always use the infant car seat harness and insure that the child and infant car seat are properly positioned according to these instructions.

⚠ WARNING: Never leave child unattended.

⚠ WARNING: Care must be taken when folding and unfolding the product to prevent finger entrapment.

- Purses, shopping bags, parcels, diaper bags or accessory items may change the balance of the stroller and cause hazardous unstable conditions.
- The maximum weight that can be carried in the storage basket is 5 lbs. The maximum weight for the parent tray is 3 lbs.
- Be certain the stroller is fully erect and latched in the open position before allowing a child near the stroller.
- Excessive weight may cause a hazardous unstable condition to exist. **DO NOT EXCEED 45 lbs TOTAL.**
- For use with two (2) children weighing no more than 22 pounds each, or two children totaling no more than 44 pounds combined. Exceeding 45 lbs will cause excessive wear and stress on the stroller and may cause a hazardous, unstable condition to exist.
- **DO NOT** use the stroller on stairways or escalators.
- **NEVER** allow your stroller to be used as a toy.
- To clean, use only mild household soap and warm water with a sponge or cloth.
- Check your stroller often for loose screws, worn parts, torn material or stitching. Replace or repair parts as needed.
- Discontinue use of stroller should it malfunction or become damaged. Please contact our customer service Parts Hotline to arrange for repair or to obtain replacement parts.

Please: If you experience any difficulty with the use of our product or have a question regarding these instructions, please contact our Customer Service Department at (800) 328-7363 between the hours of 8:00 and 4:30 Pacific Standard Time or visit us at www.babytrend.com. Please do not return the product to the store as once it is returned it cannot be re-sold and the materials and energy used to make it are wasted.

To Contact us:

Baby Trend, Inc.
1567 S. Campus Ave.
Ontario, CA 91761

Parts Hotline:
(800) 328-7363
8:00 a.m. and 4:30 p.m. Pacific Standard Time

PARTS

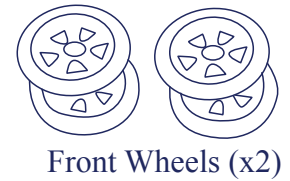
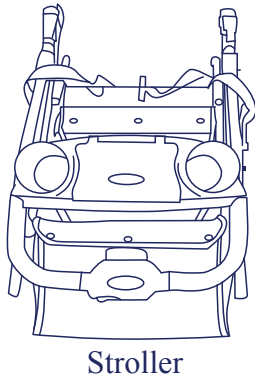

ASSEMBLING

TO ENSURE SAFE OPERATION OF YOUR STROLLER, PLEASE FOLLOW THESE INSTRUCTIONS CAREFULLY AND RETAIN THEM FOR FUTURE REFERENCE.

ASSEMBLY:

1. Remove stroller from box. NOTE: The front wheels, rear wheels, parent tray, and support bars specific to your infant car seats need to be installed prior to use.
 2. To attach the front wheels, unfold stroller and lean backwards so that it rests on the handle and rear frame tubes with the front wheel tubes pointing upward. (Fig. 1) Position the front wheel assembly over the front tube so that the large hole in the swivel assembly will slide onto the front tube. Carefully push the wheel assembly until it locks onto the front leg. Tug on the wheel assembly to ensure that it is securely attached to the stroller. (Fig. 2)
 3. Lean the stroller forward to rest on the front wheels. To attach the rear wheels, position the rear axle and wheel assembly so that the brake levers are facing the rear of the stroller. (Fig. 3.1) Press the rear wheel assembly onto the rear frame tubes, being careful that the push buttons on the forward side of each rear tube engage the hole on the forward side of each rear wheel housing. (Fig. 3.2) Tug on the rear wheel assembly to ensure that it is securely attached to the stroller and firmly locked into place.
- DO NOT** use the stroller if the wheels are not locked into place, but rather contact our customer service department immediately at (800) 328-7363, between the hours of 8:00am and 4:30pm PST, for assistance.

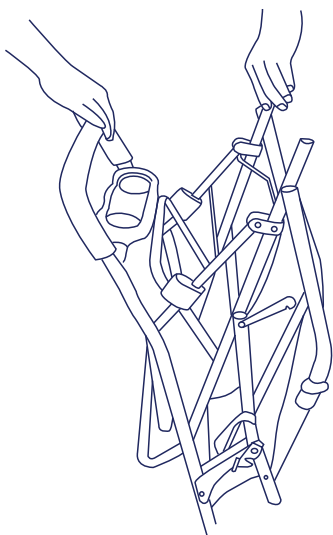

Fig. 1

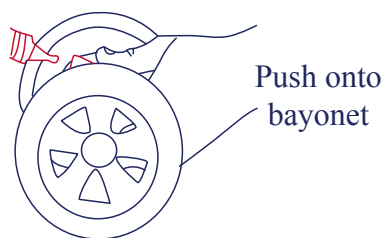

Fig. 2

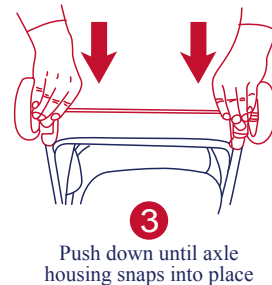
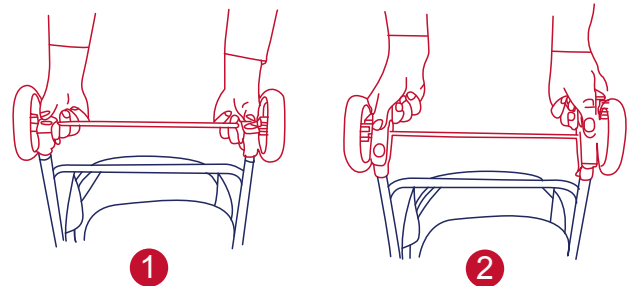

Fig. 3

⚠️WARNING: DO NOT place hot liquids in the parent tray. Hot liquids can burn your child. Do not place more than 3 pounds in the tray as it may cause a hazardous unstable condition to exist.

⚠️WARNING: ALWAYS USE the Infant Car Seat harness to avoid serious injury from falling or sliding out.

BRAKES:

⚠️WARNING: ALWAYS SET brakes when the stroller is not being pushed so that the stroller will not roll away. Never leave stroller unattended on a hill or incline as the stroller may slide down the hill.

- To engage brakes, apply light downward pressure to the brake lever located on each rear wheel. The stroller may require slight forward or rearward movement in order to line up the teeth on the brake with the each wheel brake cluster. (Fig. 4) Check that the stroller will not move and that the brakes are properly applied. To release, gently lift up on the brake lever.

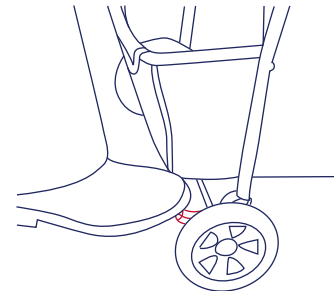

Fig. 4

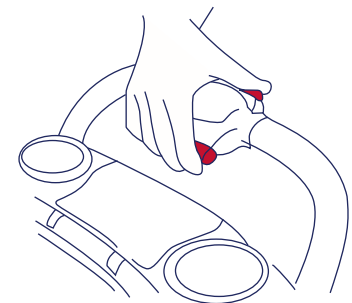

Fig. 5

TO FOLD STROLLER:

DO NOT allow children near stroller while folding.

- The front section should be folded back to reduce the folded size of the stroller. To fold the front frame, slide the plastic fittings forward then lift upward on the frame. Rotate the front frame backwards, and rest on the rear portion of the frame. (Fig. 8a & 8b)
- To fold the stroller slide the red small trigger on the top of the handle to the left with your thumb, then squeeze the red large trigger while pushing forward on the handle. (Fig. 5) Once the stroller begins to fold, release the triggers and pull backward on the front of the frame until stroller is folded. Secure the stroller in the folded position by latching the fold latch. The fold latch is located on the right side of the stroller at the intersection of the handle and the rear tube, over the extended rivet located on the lower frame tube. (Fig. 6)

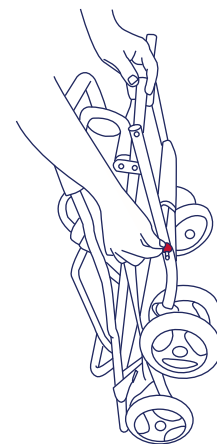

Fig. 6

TO UNFOLD STROLLER:

DO NOT allow children near stroller while unfolding.

1. Release the folding latch located on the right side.
2. Lift up on the stroller handle with both hands making sure the stroller frame is erect and locks in the open position. (Fig. 7) The stroller has spring-loaded latches on both sides of the frame. Test that both latches are fully engaged prior to placing your child in the stroller.
3. Extend the front frame by rotating it forward. (Fig. 8b). Slide the two plastic fittings forward and then back so both latch securely onto the front tubes of the stroller frame. (Fig. 8a)

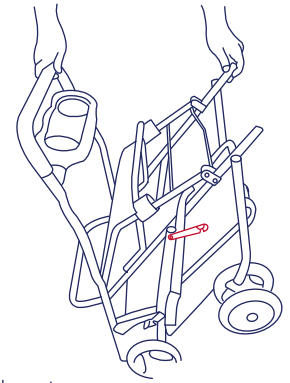

Fig. 7

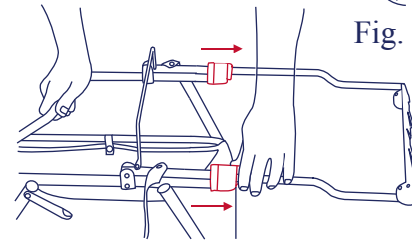

Fig. 8a

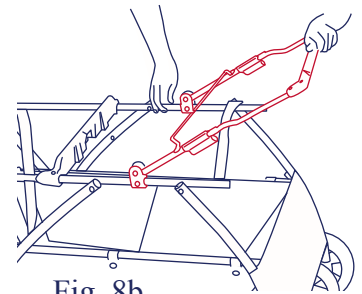

Fig. 8b

TO ATTACH AN INFANT CAR SEAT:

1. Place car seats onto snap bars with stroller open and locked in place. (Fig. 9) Please refer to the chart on next page for snap bars' positions. (Fig. 12) NOTE: Some brands of infant car seats will lock onto the snap bar, and some brands may simply rest on the bar, **you must ALWAYS** use the safety belt to secure every car seat that is placed on the Snap-N-Go.
2. Strap the safety belt over the carseat and connect the buckles together. Tighten the strap so the car seat fits snug and can't move. (Fig. 10) NOTE: Some car seats have slots for the safety belt to slide through, if you have a car seat with these slots please feed the safety belt through each slot and secure. (Fig. 11)

⚠WARNING: Avoid serious injury from falling, **ALWAYS** use the safety belt to secure both of **FRONT** and **REAR** car seats.

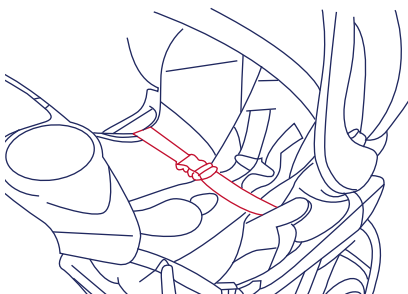

Fig. 10

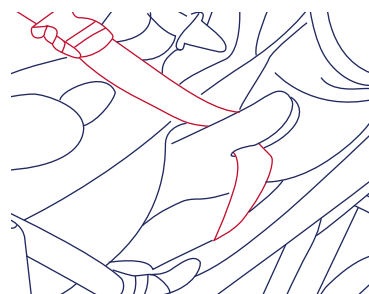

Fig. 11

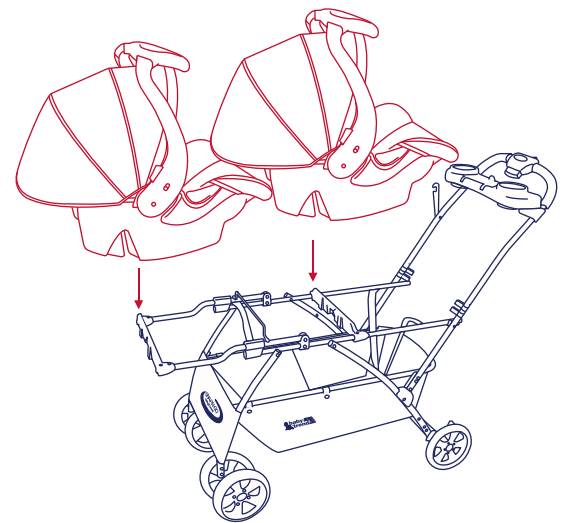

Fig. 9

IF YOU EXPERIENCE ANY DIFFICULTY IN USING THIS PRODUCT, PLEASE CONTACT OUR CUSTOMER SERVICE DEPARTMENT AT (800) 328-7363 BETWEEN THE HOURS OF 8:00AM AND 4:30PM PACIFIC STANDARD TIME FOR ASSISTANCE.

SNAP BAR POSITON CHART

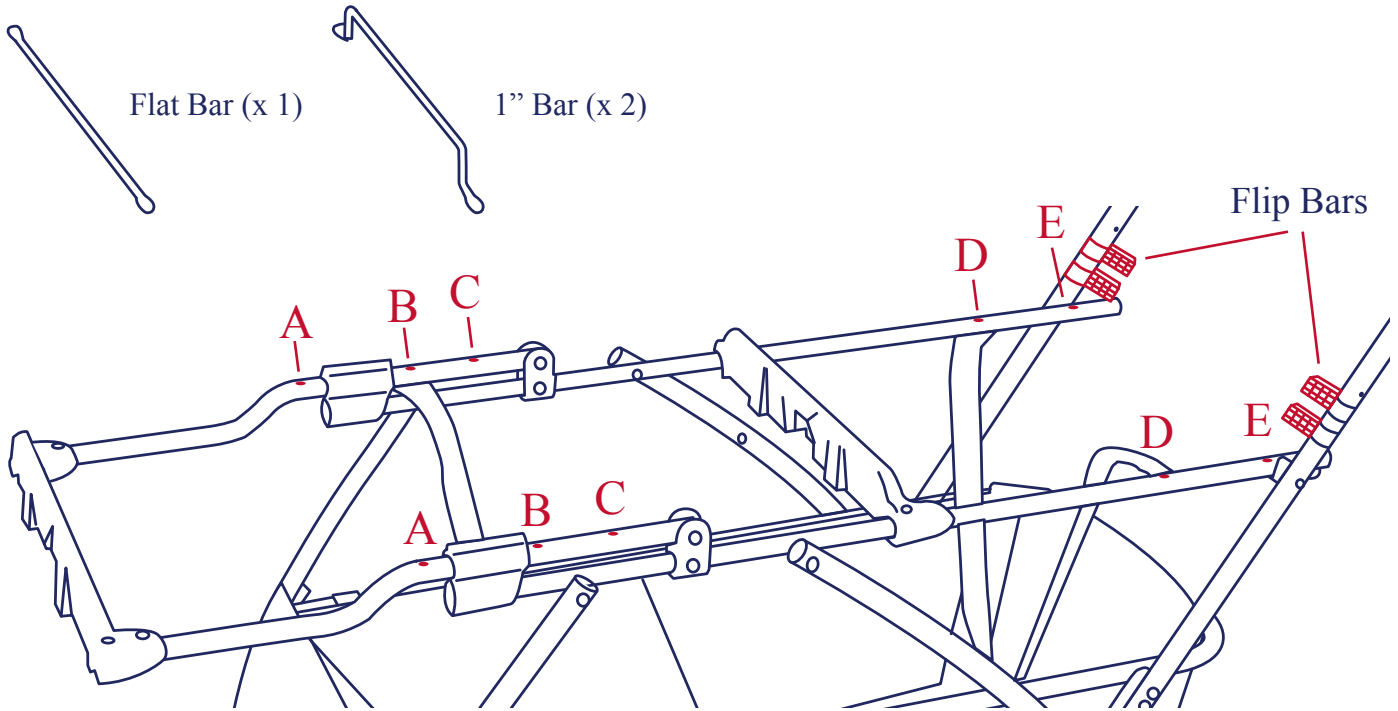

Fig. 12

CAR SEAT	FRONT BAR LOCATION		REAR BAR LOCATION	
BABY TREND	1" Bar Downwards	Hole "B"	Top Flip Bars	
BRITAX	1" Bar Downwards	Hole "C"	1" Bar Upwards	Hole "E"
EVENFLO	1" Bar Upwards	Hole "B"	Top Flip Bars	
GRACO	1" Bar Downwards	Hole "C"	1" Bar Upwards	Hole "E"
PEG PEREGO	1" Bar Downwards	Hole "A"	Flat Bar	Hole "D"



If you experience any difficulty with the use of our product or have a question regarding these instructions, please contact our Customer Service Department at (800) 328-7363 between the hours of 8:00 am and 4:30 pm (PST) or visit us online at www.babytrend.com. Please do not return to the store as once it is returned it cannot be resold and the materials and energy used to make it are wasted.