

Heat Pump-Outdoor Section

INSTALLER'S PRELIMINARY SURVEY

Step 1 — Inspect Equipment — File claim with shipping company if shipment is damaged or incomplete.

Step 2 — Complete or Consider the Following before installing the 38BQ unit:

- Consult local building code for special installation requirements.
- Provide sufficient space for coil airflow clearance, wiring and servicing of unit. See Fig. 1.
- Position unit so water or ice from roof will not drop directly on top of unit or in front of coil.
- Position outdoor unit to prevent prevailing winds from blowing directly thru fan and coil section in either direction. Avoid corners or pockets where snow is likely to drift.
- Consider effect of outdoor fan sound on conditioned space and adjacent occupied space. Place unit so discharge air does not blow toward windows that are less than 25 ft away. Do not locate unit under an overhang.
- Make provisions for condensate drainage and defrost water disposal. See Mounting Pad for details.

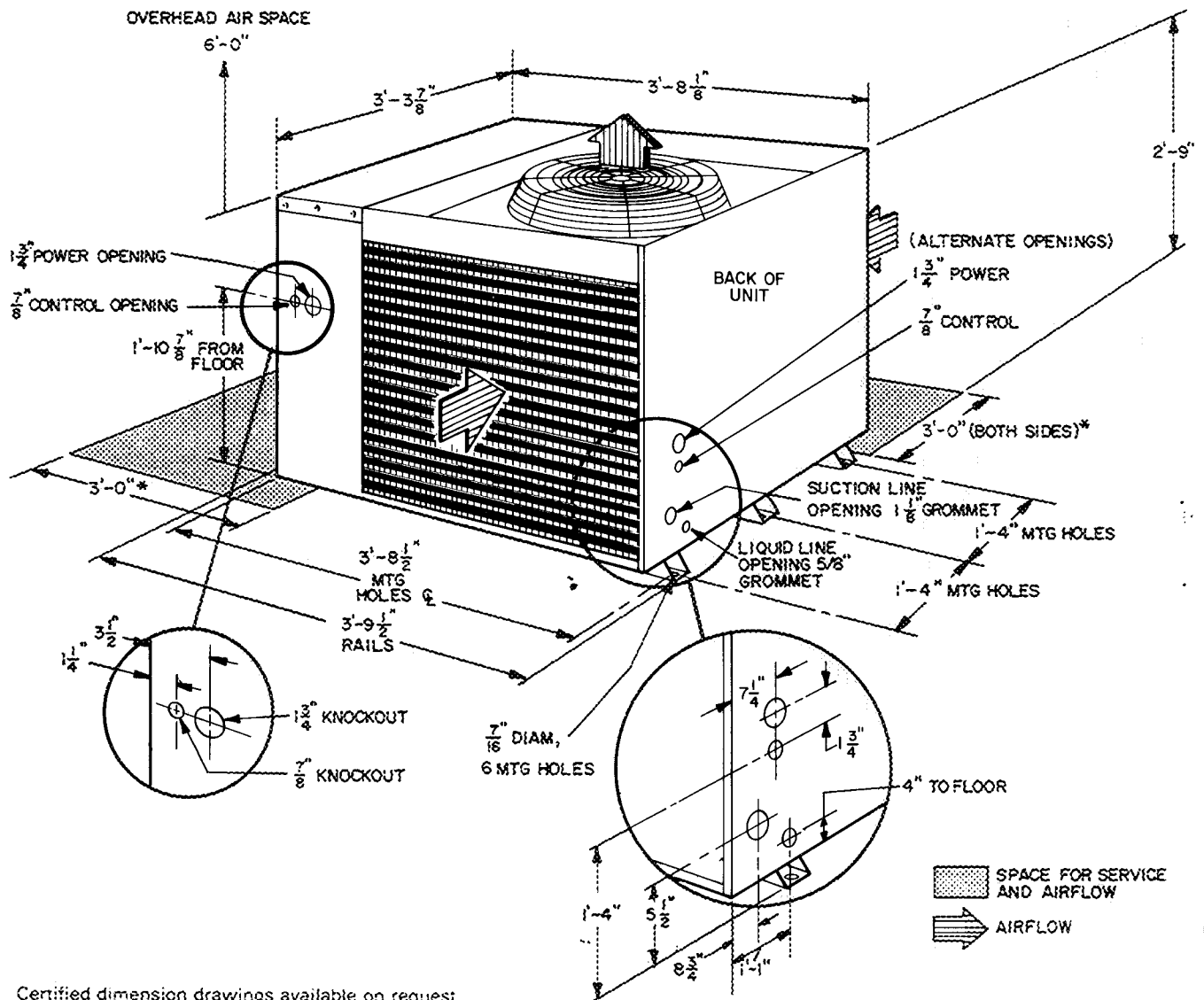

Certified dimension drawings available on request

Fig. 1 — Dimensions (38BQ008)

- g. Roof installation method for 38BQ depends on building construction and requirements of local building codes. Ensure roof will support unit weight. See Mounting Pad for details.
- h. Ensure mounting pad or platform will support unit without transmitting vibration. See Table 2 for unit weight.
- j. Maximum length of refrigerant piping allowed is 100 feet. See Table 1 for maximum vertical distance between indoor and outdoor sections.

Table 1 — Carrier-Approved 38BQ008 System

OUTDOOR UNIT 38BQ	INDOOR	HEIGHT (ft)	
		Indoor Unit	
	008	Fan Coil	Above
40BA009		30	60

Table 2 — Physical Data

UNIT	38BQ008
OPERATING WT (lb)	590
REFRIGERANT	R-22
Operating Charge (lb)*	19.7
Factory Holding Charge (lb)*	2.0
COMPRESSOR	06DA818
Cylinders	4
Rpm	1750
Oil Charge (pts)	7
OUTDOOR FANS	
Discharge Number	1
Rpm	1075
Blade Diameter (in.)	22
Motor Hp	1/2
Cfm	5000
OUTDOOR COIL	4-Row, 12 Fins/in
Face Area (sq ft)	12.46

*Based on approximately 25 ft of interconnecting piping. Unit supplied with factory holding charge.

MOUNTING PAD

Step 3 — On the Ground: Mount Unit on a Solid Level Concrete Pad. See Fig. 2 for pad dimensions. Ensure pad does not obstruct coil slots in unit basepan. (Slots drain water during heating cycle.) Construct pad at least 6 in. thick to provide clearance under basepan coil slots for drainage and ice buildup. *In areas where prolonged subfreezing temperatures or drifting or heavy snows occur, increase clearance to 12 to 18 inches. If climatic conditions dictate, construct an angle iron frame to support unit 12 to 18 in. off concrete pad. Cross angle of frame must not obstruct basepan coil slots. Extend a gravel apron around pad for condensate and defrost water drainage field.*

Step 4 — On the Roof: Mount Unit on a Level Platform or Frame. Unit must be elevated for proper clearance as described under ground installation above. Roof design and water drainage must be planned to prevent unit from setting in water. Flash all roof openings to prevent leaks.

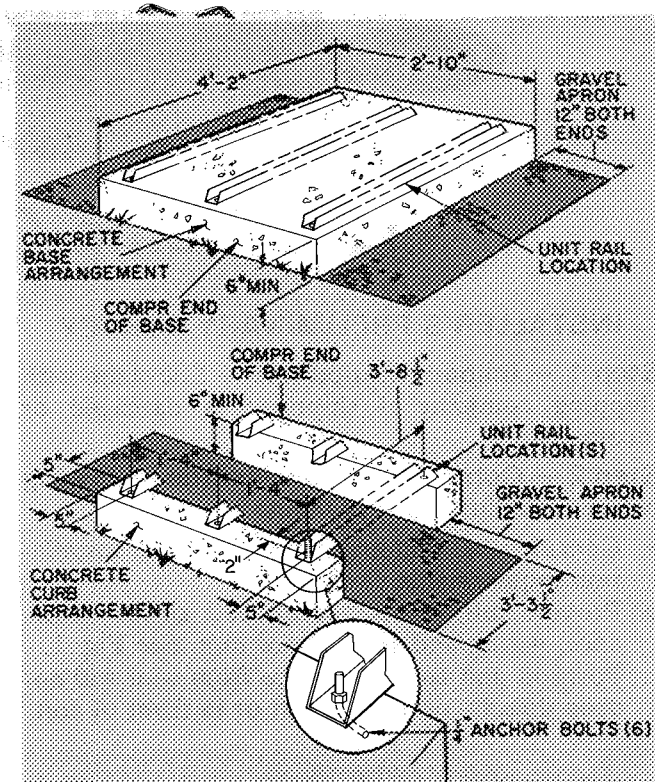

Fig. 2 — 38BQ008 Base Dimensions

PIPING CONNECTIONS

The 38BQ units can be connected to R-22 indoor units by using field-supplied tubing of refrigerant grade. Refer to Fig. 1 for unit connection sizes.

Connection Recommendations — Do not use damaged or contaminated tubing. Do not use less than 10 ft of liquid line. Bend or coil to use up excess tubing.

Step 5 — Extend Refrigerant Liquid and Suction Lines into 38BQ heat pump where indicated on Fig. 1.

Step 6 — Connect Refrigerant Lines to Fittings on Unit Suction and Liquid Service Valves — Refer to Fig. 3 and proceed as follows:

1. Ensure compressor discharge service valve and liquid line valve are closed.
2. Loosen the 1/2-in. flare nut on the liquid valve to bleed the oil and refrigerant from the run-around loop. Completely unscrew the flare nut and bend the tube away.
3. Open suction valve momentarily to blow any trapped oil out of loop.
4. Unswear and remove the run-around loop at fitting.
5. Connect the liquid line from the indoor section to the 1/2-in. male flare liquid line valve connection.
6. Connect suction line to indoor section and extend line to outdoor unit. Purge indoor coil and tubing system (steps 7, 8 and 9) before connecting suction line to outdoor unit.

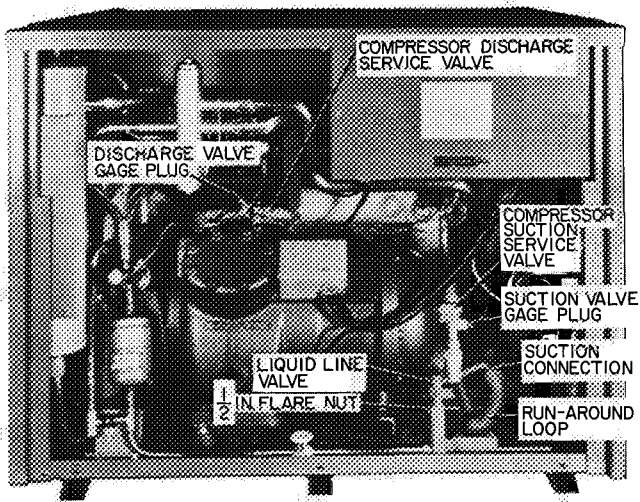
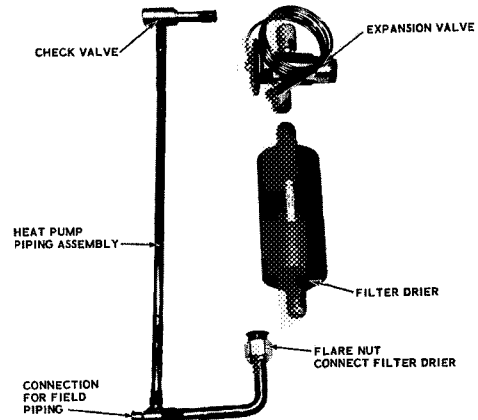

Fig. 3 — Typical Component Arrangement

7. Connect a cylinder of refrigerant to the gage port on either the liquid line valve or the compressor discharge service valve.
8. Open service valve on refrigerant cylinder.
9. Open the liquid line valve on the outdoor section approximately a quarter turn for 10 to 15 seconds to purge the air from liquid line, indoor coil and suction line.
10. Close all valves and remove refrigerant cylinder.
11. Open compressor suction service valve midway to purge the suction line of the outdoor section.
12. Remove the suction valve gage plug to provide a pressure relief open for soldering.
13. Solder the 1-1/8 in. suction line from the indoor section to the outdoor unit suction connection where the run-around loop was removed.
14. Remove the discharge valve gage plug. Then, frontseat valve.
15. Momentarily crack open the liquid line valve to repurge the short length of the suction line and the compressor.
16. Replace the suction valve gage plug and then the discharge valve gage plug while a small amount of refrigerant is still bleeding from the ports.
17. Open the liquid line valve momentarily to build up pressure in system and check for leaks.
18. Fully open the suction, discharge and liquid line valve.

- Connect this unit with a 40BA009 indoor fan-coil section to provide a complete heat pump installation. Where supplementary resistance heat is required, use the strip heater packages designed for use with the indoor section used. At least one strip heater should be used to temper the air during the defrost cycle and to shorten the defrost cycle.
- A carton containing the necessary piping, expansion valve, and check valve assembly for connecting the matched indoor coil for heat pump use is included with the Outdoor Section. (See Fig. 4.) The

indoor fan relay, shipped with 40BA009 unit, is to be mounted near the Indoor Section for control of the indoor fan motor.



→ Fig. 4 — Contents of Heat Pump Conversion Package for 40BA009 Fan Coil

- Figure 5 shows the heat pump conversion piping filter-drier and expansion valve installed on the 40BA009 unit. To install, cut off the end of the side outlet tube of the distributor, being careful about leaving chips or burrs inside the tube. Position the check valve and tube assembly. Slide the check valve over the side outlet tube and “sweat” the joint. Use the expansion valve and filter-drier to locate the lower end of the tube assembly.
- The expansion valve and filter-drier are in the same locations as on a straight cooling installation.

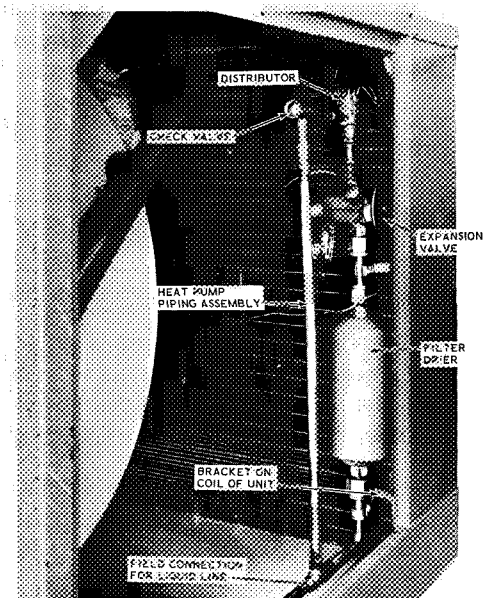

Fig. 5 — 40BA009 with Heat Pump Conversion Piping Installed

ELECTRICAL DATA AND WIRING

Field wiring must comply with local and national fire, safety and electrical codes. Voltage to unit must be within the range given in Table 3 and on unit nameplate. Contact local power company for correction of improper line voltage.

Table 3 — Electrical Data — 60-Hz

UNIT	V/PH/HZ	VOLTAGE RANGE*		COMPRESSOR		FAN MOTOR		POWER SUPPLY	
		Min	Max	LRA	RLA	Qty	FLA	Min Ckt Amps	Max Fuse Amps
38BQ008	208-230/3/60	187	253	137	38.5	1	3.6	51.7	60
	460/3/60	414	528	62	16.0	1	1.8	21.8	35

FLA — Full Load Amps
LRA — Locked Rotor Amps
RLA — Rated Load Amps

*Units are suitable for use on electrical systems where voltage supplied to the unit terminals is not below or above the limits shown

NOTES

- 1 Fan motors are single phase and same voltage as unit
- 2 Compressor and fan motors have inherent thermal protection
- 3 Maximum allowable voltage unbalance between phases is 2%

Operation of unit on improper line voltage constitutes abuse and may affect Carrier Warranty.

See Table 3 for recommended fuse sizes.

→ Mount the remote relay box assembly in accordance with instructions supplied with fan-coil units. This box is supplied with the 40BA009 unit.

Step 7 — Install a Branch Circuit Fused Disconnect of adequate size to handle unit starting current. Provide a separate fused disconnect for outdoor unit, indoor unit and for each accessory electric heater circuit as required. (See electric heater Installation, Start-Up and Service Instructions.) Locate disconnect(s) within sight of and readily accessible from the unit, per section 440-14 of National Electrical Code (NEC).

Step 8 — Bring Line Power Leads into Unit — Extend leads from fused disconnect thru hole in back of unit into control box. Connect field power wiring to compressor contactor as shown in Fig. 6.

Step 9 — Connect Ground Lead to a Ground Lug in Control Box for safety. See Fig. 6.

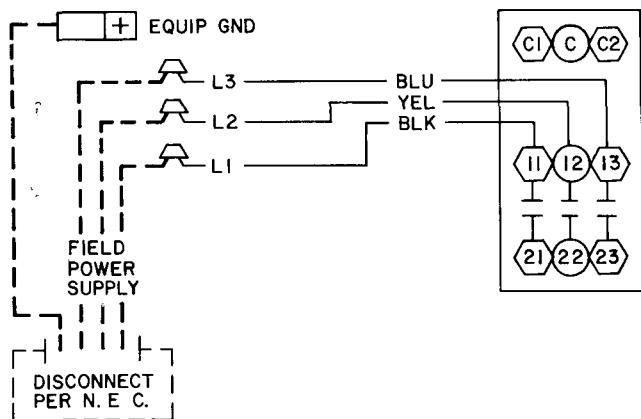

Fig. 6 — Power Wiring Connections

Step 10 — See Indoor Unit and Electric Heater Installation, Start-Up and Service Instructions for line power wiring details. Control wiring is shown in Fig. 7.

Step 11 — Control Power Wiring (24 v) is brought thru hole provided in unit, Fig. 1. Extend

leads to 38BQ unit control wiring terminal board. Connect leads to terminal board as indicated in Fig. 7.

The 38BQ unit transformer supplies 24-volt power for complete system including accessory electric heater.

HH07AT070 THERMOSTAT
 WITH
 HH93AZ076 SUBBASE

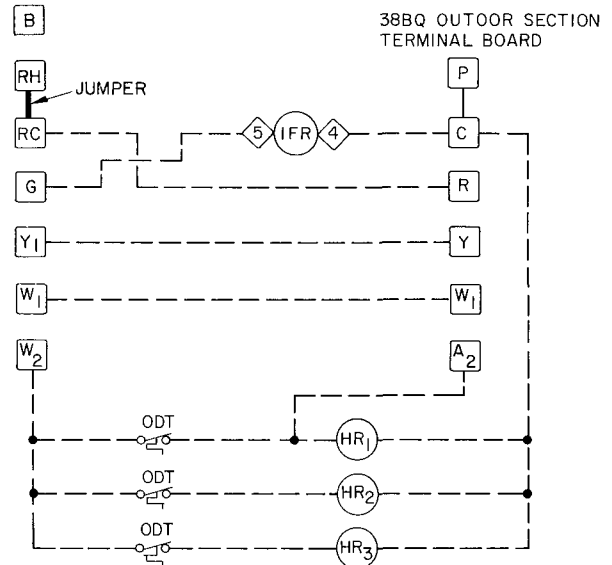

*Remove jumper when emergency heat switch is added

Fig. 7 — Control Wiring Connections (With 40BA Electric Heaters)

INITIAL START-UP

Before Starting Unit, check the following:

1. All internal wiring connections must be tight.
2. Electrical power source must agree with unit nameplate rating.
3. All service valves must be open.
4. It is recommended that the compressor crankcase heater be energized a minimum of 24 hours before starting unit. To energize heater only, turn the thermostat to OFF position and close electrical disconnect to 38BQ unit.

Heat Anticipator Settings for Room Thermostat (HH07AT070).

1. Set the adjustment lever for the first-stage anticipator at 0.5 (left side).

- Set the adjustment lever for the second-stage anticipator at 0.35 (right side).

These settings may be changed slightly to provide a greater degree of comfort for a particular installation.

Accessory Outdoor Thermostat provides adjustable outdoor control of accessory electric heater. This thermostat makes contact when a drop in outdoor temperature occurs. It energizes a stage of electric heat when the outdoor temperature setting is reached, provided the room thermostat is on the second stage of heating. One outdoor thermostat is recommended for each stage of electric heat after the first stage. Set the outdoor thermostat progressively lower for each stage. Refer to heat load of building and unit capacity to determine the correct outdoor thermostat settings. The accessory emergency heater relay is automatically energized by the manually operated emergency heat switch in the indoor thermostat subbase. This relay locks out compressor and bypasses the outdoor thermostat(s) for electric heater operation during heat pump shutdown. See 40BA electric heater Installation, Start-Up and Service Instructions for installation of outdoor thermostat and emergency heater relay. Also, see Fig. 8.

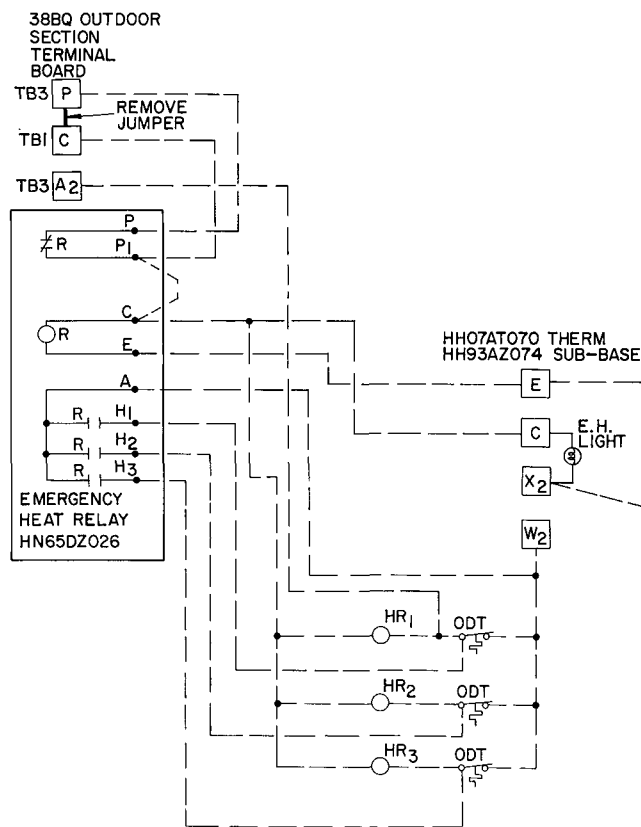

→ **Fig. 8 — Emergency Heat Relay Schematic (38BQ008 with 40BA009 Electric Heaters)**

To Start Unit — (Ensure crankcase heater has been energized for 24 hours.) Adjust the thermostat as follows:

- Set selector switch at OFF.

- Set fan switch as desired (FAN) (AUTO.).
- Turn on main disconnect switch(es) to indoor and outdoor units.
- Set thermostat dial to the desired temperature.
- Set selector switch at HEAT or COOL. Check system refrigerant charge. See Refrigerant Charging.

SERVICE

Refrigerant Charging — The 38BQ unit is shipped with a holding charge of 2 lbs. The correct operating charge for the complete system when connected to 40BA indoor unit with 25 ft of tubing of recommended diameter is 19.7 lbs. Adjust system charge for refrigerant line lengths and diameters that differ from 25 ft and 3/8-in. OD (liquid line), respectively, using refrigerant weights shown in table below. (Twenty-five feet of 3/8-in. OD tubing contains 14.4 oz of R-22.) Add R-22 charge to system if liquid line is over 25 ft; remove charge if liquid line is shorter than 25 feet.

LIQUID DIAM (in.)	OUNCES OF R-22/FT LENGTH OF LIQUID LINE
3/8	58
5/16	36
1/4	21

When recharging during heating or cooling season is necessary, weigh in total charge indicated in Table 1. (Charge must be weighed in during heating season.) Remove any refrigerant remaining in system before recharging. If system has lost complete charge, evacuate system to 500 microns (29.7 in. vacuum) before recharging. Service port connections are provided on liquid and suction line service valves for evacuation and charging. (See Fig. 11.) Dial-a-charge charging cylinder is an accurate device used to recharge systems by weight. These cylinders are available at refrigeration supply firms.

To check and/or adjust charge during cooling season, use correct Cooling Cycle Charging Chart, Fig. 9. Charging chart may also be used as an alternate method of recharging system.

To check *system operation* during heating cycle, use Heating Cycle Operation Check Chart, Fig. 10. This chart indicates whether a correct relationship exists between system operating pressures and air temperatures entering indoor and outdoor units. If pressure and temperature lines do not intersect on chart, the system refrigerant charge may not be correct or other system abnormalities may exist. Do not use Heating Cycle Operation Check Chart to adjust refrigerant charge. Weigh charge into system.

Unit Controls and Safety Devices

LIQUID LINE LOW-PRESSURE CONTROL (LLP) is connected in liquid line to work with com-

pressor internal thermostat in providing loss-of-charge protection during the heating cycle. Control is mounted in control box.

With a high-side leak, pressure gradually decreases until low-pressure control stops the compressor. (Pressure control settings are shown in Table 4.)

Table 4 — Pressure Switch Settings

UNIT 38BQ	HIGH PRESSURE		LOW PRESSURE		LIQUID LINE LOW	
	Cut-in	Cutout	Cut-in	Cutout	Cut-in	Cutout
008	328 ± 19	428 ± 4	60 ⁺¹⁵ ₋₀	27 ± 4	15 ± 7	5 ± 2

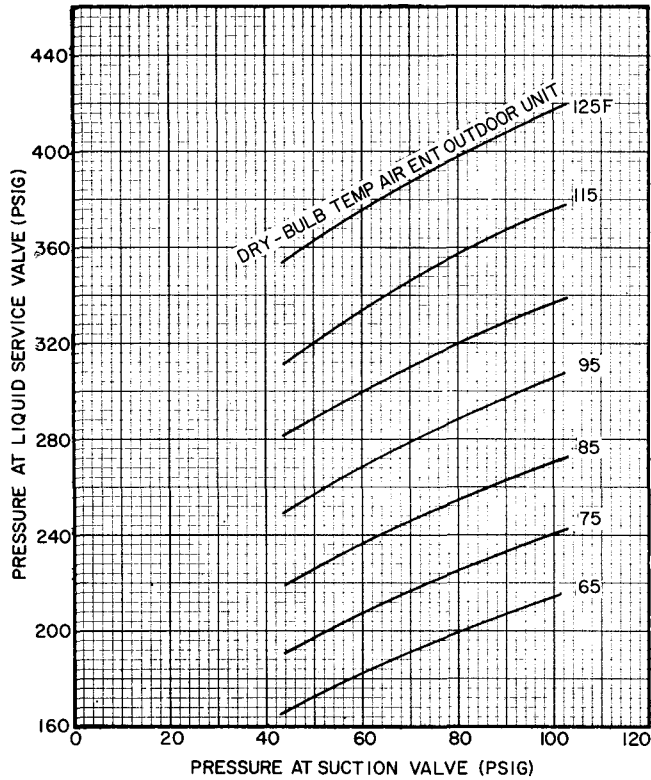

Fig. 9 — 38BQ008 with 40BA009 Cooling Cycle Charging Chart (R-22)

With a low-side leak there will always be some pressure in the liquid line. However, compressor motor temperature will increase because of insufficient suction gas cooling. This causes internal thermostat to actuate and stop compressor. When compressor stops, system pressure equalizes and contacts on pressure control open. The compressor cannot restart until leak is repaired and system recharged.

TIME GUARD® CIRCUIT for compressor causes a 5-minute delay before restarting compressor after shutdown for any reason. On starting, the Time Guard timer causes a delay of 15 seconds after thermostat closes before compressor will start. On com-

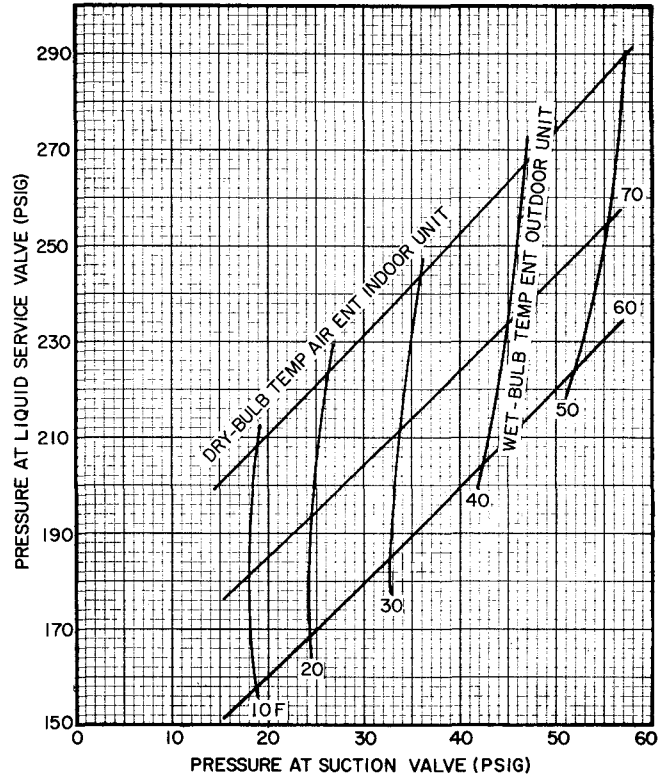

Fig. 10 — 38BQ008 with 40BA009 Heating Cycle Operation Check Chart (R-22)

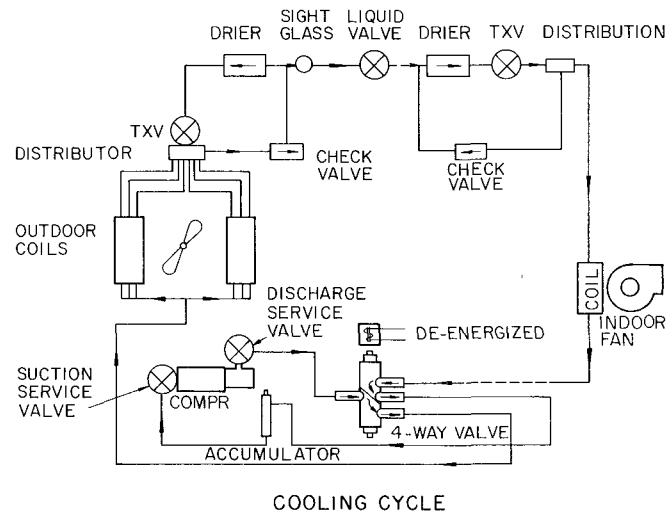
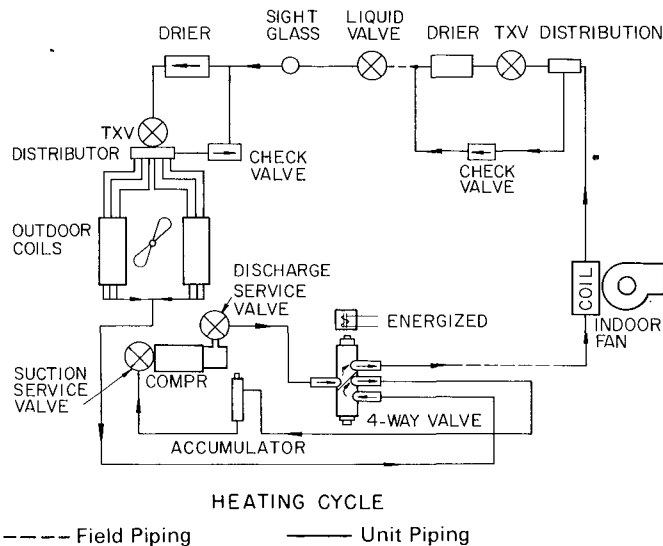

Fig. 11 — 38BQ Typical Piping Diagram

pressor shutdown, the timer recycles for 4 minutes 45 seconds. During this time, the compressor cannot restart.

CRANKCASE HEATER is operated from the normally-closed contacts of the control relay and is energized automatically when control relay is de-energized (compressor off).

The purpose of the heater is to keep the crankcase warm during the off cycle and thus prevent dilution of the oil with refrigerant. This assures good lubrication and prevents loss of oil from crankcase during start-up.

If the electrical disconnect switch to the outside unit has been off for an extended period of time, the crankcase heater should be energized for 24 hours before starting the compressor.

INTERNAL CURRENT AND TEMPERATURE SENSITIVE OVERLOADS reset automatically when internal motor temperature drops to a safe level (*overloads may require up to 45 minutes to reset*). When an internal overload is suspected of being open, check by using an ohmmeter or continuity tester. If necessary, refer to Carrier Standard Service Techniques Manual, Chapter 2, for complete instructions.

HIGH-PRESSURE RELIEF VALVE is located in compressor. Relief valve opens at a pressure differential of approximately 600 psi between suction (low side) and discharge (high side) to allow pressure equalization.

DEFROST CONTROL, consisting of a defrost timer, defrost thermostat and defrost relay, interrupts normal system heating operation if enough frost forms on outdoor coil to impair unit performance. Defrost control simultaneously stops outdoor fan, de-energizes reversing valve solenoid to return system to cooling cycle (outdoor unit as condenser, indoor unit as evaporator), and activates accessory electric heater. Unit can defrost every 90 minutes, but will defrost only if required.

For the heat pump to defrost, 2 conditions are necessary:

1. Defrost timer contacts must be closed.
2. Refrigerant temperature from outdoor unit must be cold enough to cause defrost thermostat contacts to close. Contacts close at:

UNIT 38BQ	TEMPERATURE (F)	
	Open	Close
008	65 ± 6	40 ⁺⁰ ₋₆

Every 90 minutes of elapsed running time, the defrost timer contacts close for 10 seconds. If the defrost thermostat contacts are closed, the unit defrosts. The defrost timer limits defrosting period to 10 minutes. Normally the frost is removed and the

defrost thermostat contacts will open to terminate defrosting before 10 minutes have elapsed. Defrost thermostat contacts open at temperatures shown in above table. When defrosting is terminated, the outdoor fan motor and reversing valve solenoid are energized returning unit to heating cycle.

HEAT PUMP CIRCUITS shown in Fig. 11 are refrigerant flow diagrams for heating and cooling cycles.

Compressor Removal — See Table 2 for compressor information and Fig. 3 for component location.

Follow safety codes and wear safety glasses and work gloves. Have quenching cloth available (step 8).

1. Shut off power to unit. Remove unit compressor compartment access panel (front or side of unit).
2. Remove refrigerant from system using refrigerant removal methods described in Carrier Standard Service Techniques Manual, Chapter 1.
3. Disconnect compressor wiring at compressor terminal box.
4. Unfasten screws holding unit control box in place. Remove control box from unit.
5. Using a tubing cutter, cut suction and discharge (hot gas) lines at convenient place near compressor for easy reassembly to new compressor with copper slip couplings.

CAUTION: Excessive movement of copper lines at compressor may cause a break where lines connect to outdoor coil.

6. Remove crankcase heater from compressor base.
7. Remove compressor hold-down bolts and lift compressor out.
8. Carefully unbraid suction and discharge line piping stubs from compressor. If oil vapor in piping stubs ignites, use quenching cloth.
9. Braze piping stubs (removed in step 8) onto new compressor.
10. Clean system. Add new liquid line filter-drier.
11. Install new compressor in unit. Braze suction and discharge lines to compressor piping stubs (at points where cut, step 5) using field-supplied copper couplings. Ensure that compressor hold-down bolts are in place. Connect wiring.
12. Evacuate and recharge unit.

Outdoor Fan Position — Required fan position is shown in Fig. 12. Adjust fan by loosening setscrews and moving blades. Ensure fan is centered in the venturi.

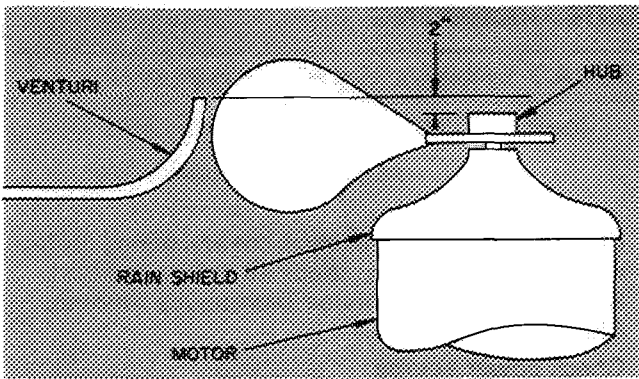

Fig. 12 — Fan Adjustment — 38BQ008

MAINTENANCE

Ensure power is off to unit before performing required maintenance.

Outdoor Coil Cleaning — Remove unit service panels for access to outdoor coil. Inspect coil periodically. Clean coil with water at the beginning of every cooling season or more often if required. Use ordinary garden hose at a pressure high enough to clean efficiently. For best results, spray coil fins from inside to outside the unit and top to bottom between rows of tubing. Flush dirt from basepan by spraying water thru top of unit. Avoid splashing mud on coil or water on fan motor. Ensure water drainage slots under outdoor coil are not obstructed.

Lubrication

COMPRESSOR contains factory oil charge. Replace oil when lost. See Table 2 for oil recharge. If necessary, refer to Carrier Standard Service Techniques Manual, Chapter 1, page 1-21, for oil recharging procedure. Use Carrier PP33-1, Texaco Capella B or Suniso 3G oil.

CONDENSER fan bearings are factory sealed and do not require lubrication.

→ **TROUBLESHOOTING GUIDE — COOLING**

SYMPTOM AND PROBABLE CAUSE	PROBABLE REMEDY
<p>COMPRESSOR WILL NOT RUN OR SHUTS OFF — WILL NOT RESTART</p> <p>Contactor open</p> <ol style="list-style-type: none"> 1. Burned out transformer, open thermostat circuit, open overload. 2. Power supply interrupted. 3. Power circuit is open due to loose electrical connection, open compressor safety device. Contactor coil defective. 	<ol style="list-style-type: none"> 1. Check control circuit component and wiring. Refer to unit label diagram, check all safety devices. Refer to Standard Service Techniques Manual, Chapter 2, Electrical. 2. Check power source. 3. Check power wire connection for tightness. Check compressor internal thermostat, overloads (see label diagram). Check contactor; replace if defective.
<p>Contactor Closed, or Closes then Opens</p> <ol style="list-style-type: none"> 1. Compressor power is out, compressor motor is burned out or internal overloads are open. Timer circuit (clock or switch) is faulty. 2. Compressor stuck. 3. Control circuit open due to faulty low-voltage transformer or defective control circuit 	<ol style="list-style-type: none"> 1. Check main power supply and wiring. Refer to Electrical Data table and label diagram. Check defrost timer circuit relay. Check defrost control contacts. Replace defective controls. 2. Check compressor motor windings. 3. Review label diagrams. Check control power wires, connections. Check control transformer power output (24 v). Check remote control center contacts and temperature settings.
<p>COMPRESSOR RUNS BUT COOLING IS INSUFFICIENT</p> <ol style="list-style-type: none"> 1. Low suction pressure or incorrect superheat. 2. Restricted airflow due to dirty filters, duct obstruction or indoor coil icing. Refrigerant system obstructed. Filter-drier obstructed or refrigerant flow is insufficient. 3. High suction pressure/low head pressure due to open internal pressure relief, defective compressor valves or faulty reversing valve. 4. High suction pressure/low superheat (compressor may be flooding). 	<ol style="list-style-type: none"> 1. Check Refrigerant Charging procedure, charging charts. 2. Check indoor air system for obstructions — dirty filters, ductwork debris, improper fan speed. Expansion valve improperly sized. 3. Check Carrier Compressor Service Manual for compressor repair procedures. See Compressor Removal. Check reversing valve solenoid operation and valve seats. 4. Check refrigerant flow device. Check that maximum elevation between indoor and outdoor units is not too great. Check refrigerant charge.
<p>COMPRESSOR CYCLES ON AND OFF</p> <ol style="list-style-type: none"> 1. Internal overloads are opening or refrigerant system dirty. High or low pressure switch is opening. 2. Faulty timer or defrost control operation. 3. Fan motors operate intermittently. 4. Reversing valve in mid-position. 	<ol style="list-style-type: none"> 1. Check refrigerant system for noncondensables, or improper charge. See Refrigerant Charging. Check for airflow obstructions. See Coil Cleaning. 2. Check timer or defrost control relays and contacts. 3. Check motor leads and overloads. 4. Check reversing valve solenoid. See label diagram. Check that dirt in refrigerant system does not cause valve to "hang up"

→ **TROUBLESHOOTING GUIDE — HEATING**

SYMPTOM AND PROBABLE CAUSE	PROBABLE REMEDY
<p>NO HEATING (Compressor Will Not Run)</p> <ol style="list-style-type: none"> 1. Main power circuit open. 2. Control power circuit open or faulty. 3. Defrost control malfunctioning. 	<ol style="list-style-type: none"> 1. Check power supply, main power wire connections, fuses. See Electrical Data. 2. Check low voltage transformer, remote control center, control relay and contacts, timer relay and motor, compressor overloads and pressurestats for faulty operation. Review component headings in Service section. Check unit label diagram(s). 3. Check Defrost control procedure to be sure defrost thermostat and relay are operational.
<p>INSUFFICIENT HEATING (Compressor Runs or Cycles)</p> <ol style="list-style-type: none"> 1. Low suction and low head pressure due to coil obstruction in airflow or refrigerant circuit. 2. High suction, low superheat. 3. Frozen outdoor coil. 4. Accessory electric resistance heaters not operating (indoor unit). 5. High suction, low head pressures (caused by refrigerant system or indoor fan problem). 6. Low suction, high head pressures (may be accompanied by low airflow at air outlets). 	<ol style="list-style-type: none"> 1. Check coil for obstruction (dirt, debris). Check that outdoor air fan is correctly positioned and turns freely. Review fan clearance requirements and coil cleaning procedure. Check liquid line filter-drier. 2. Check refrigerant flow device. Check refrigerant charge. 3. Check fan operation, coil cleanliness. Check defrost control circuit. Check refrigerant charge (use Charging Charts and/or Operational Check Charts). 4. Check heater power supply, outdoor thermostats and their settings. Check that heater elements are not broken. 5. Reversing valve may be leaking or "hung-up." Check valve and its solenoid for correct operation. Replace if suspect. Indoor fan motor capacitor may be defective. Replace capacitor. Fan may be cycling on overloads. Check overloads, loose terminal connections. Fan motor may be burned out. Check and replace or lubricate. See Fan Adjustment. Replace or repair motor or fan as necessary. 6. Check for restricted refrigerant system component. Check Heating Operational Check charts to detect even charge. Check system for non-condensables. Refer to Standard Service Techniques Manual, Chapter 1, Refrigerants.

For replacement items use Carrier Specified Parts.

Manufacturer reserves the right to discontinue, or change at any time, specifications or designs without notice and without incurring obligations.

Book	1	4
Tab	5a	5a