

HUAWEI

**Aolynk
WDR814g / WDR814lg
ADSL2+ Wireless Router**

User's Manual

Aolynk WDR814g / WDR814lg ADSL2+ Wireless Router User's Manual

Volume

Manual Version

Product Version

BOM

Huawei Technologies Co., Ltd. provides customers with comprehensive technical support and service. Please feel free to contact our local office or company headquarters.

Huawei Technologies Co., Ltd.

Address: Administration Building, Huawei Technologies Co., Ltd.,
Bantian, Longgang District, Shenzhen, P. R. China

Postal Code: 518129

Website: <http://www.huawei-3com.com>



Email: support@huawei-3com.com

Copyright © 2004 Huawei Technologies Co., Ltd.

All Rights Reserved

No part of this document may be reproduced or transmitted in any form or by any means without prior written consent of Huawei Technologies Co., Ltd.

Trademarks

 , HUAWEI, C&C08, EAST8000, HONET,  , ViewPoint, INTess, ETS, DMC, TELLIN, InfoLink, Netkey, Quidway, SYNLOCK, Radium,  M900/M1800, TELESIGHT, Quidview, Musa, Airbridge, Tellwin, Inmedia, VRP, DOPRA, iTELLIN, HUAWEIOptiX, C&C08 iNET, NETENGINE, OptiX, iSite, U-SYS, iMUSE, OpenEye, Lansway, SmartAX, infoX, TopEng are trademarks of Huawei Technologies Co., Ltd.

All other trademarks mentioned in this manual are the property of their respective holders.

Notice

The information in this document is subject to change without notice. Every effort has been made in the preparation of this document to ensure accuracy of the contents, but all statements, information, and recommendations in this document don't constitute the warranty of any kind, express or implied.

Contents

1 Introduction.....	7
1.1 About the ADSL Wireless Router	7
1.2 Contents of the ADSL Wireless Router Package	8
1.3 Features of the ADSL Wireless Router.....	9
2 Hardware Installation & Setup.....	10
2.1 Rear Panel & Connections	10
2.2 Front Panel LEDs.....	11
2.3 POTS Splitter	12
2.4 System Requirements and Setup	12
2.4.1 Installing the TCP/IP Protocol	13
2.4.2 Fixed IP Addresses Configuration	16
2.4.3 Installing the USB driver	18
3 Internet Access.....	22
3.1 Prepare your network	22
3.2 Web-based User Interface.....	23
3.3 Quick Start this ADSL Wireless Router.....	24
3.4 WAN Setup	25
3.4.1 Internet Connection Setup	25
3.4.2 DDNS Setup.....	29
3.4.3 NTP Setup.....	30
3.5 LAN Setup	31
3.5.1 LAN IP setting & DHCP setting	31
3.5.2 Routing Setting.....	32
3.6 Wireless Setup	34
3.7 Advanced Wireless Setting	35
3.8 Advanced Applications.....	38
3.9 Security.....	38

3.9.1 Access Policy	38
3.9.2 Firewall.....	39
3.10 Services	40
3.10.1 Virtual Server.....	40
3.10.2 Forwarding	42
3.10.3 Trigger.....	43
3.10.4 DMZ Host.....	44
4 Management.....	45
4.1 Management Settings	45
4.2 Log	46
4.3 Diagnostic-Ping.....	47
4.4 Upgrade Firmware.....	48
5 Troubleshooting.....	50
A FAQ	52
B Technical Specifications	54
C Glossary	56

About this Manual

Related Manuals

None

Organization

The manual has the following organization.

Chapter	Description
Chapter 1 Introduction	This chapter describes the package contents and provides a list of features and application illustrations of the ADSL Wireless Router.
Chapter 2 Hardware Installation & Setup	This chapter provides information about your ADSL Wireless Router's physical features and gives step-by-step installation instructions for hardware installation and software configuration.
Chapter 3 Internet Access	This chapter describes the procedures necessary to configure the basic functions and begin using your ADSL Wireless Router. If you follow these procedures correctly, there should be no problem in accessing the Internet via your ADSL Wireless Router.
Chapter 4 Advanced Applications	This chapter provides information on how to set up and use the advanced functions of your ADSL Wireless Router.
Chapter 5 Management	This chapter provides information on using Macintosh computers in your network. The instructions given here are for system software version 8.0 or above, which comes with the TCP/IP Protocol preloaded and supports DHCP Addressing.
Chapter 6 Troubleshooting	This chapter provides solutions to problems you may encounter during installation and operation of your ADSL Wireless Router.
Appendix A FAQ
Appendix B Technical Specifications
Appendix C Glossary

Intended Audience

The manual is for:

- n WDR814g ADSL2+ Wireless Router
- n WDR814lg ADSL2+ Wireless Router

Conventions

- n The manual uses the following conventions.

Symbol Conventions

Symbol	Description
& Important Note:	An important note notice with this symbol helps you avoid an undesirable situation or indicates important supplementary information.
& Note:	A note notice with this symbol indicates additional, helpful, non-critical information.

GUI Conventions

Convention	Description
Boldface	Button names and menu items are in Boldface. For example, Click OK .
/	Multi-level menus are in bold and separated by forward slashes. For example, Select the File/Create/Folder menu.

Convention	Description
< >	Button name are inside angle brackets. For example, click the <OK> button
[]	Window names, menu items, data table and field names are inside square brackets. For example, pop up the [New User] window.
/	Multi-level menus are separated by forward slashes. For example, [File/Create/Folder].

Keyboard Operation

Format	Description
<Key>	Press the key with the key name inside angle brackets. For example, <Enter>, <Tab>, <Backspace>, or <A>.
<Key1 + Key2>	Press the keys concurrently. For example, <Ctrl+Alt+A> means the three keys should be pressed concurrently.
<Key1, Key2>	Press the keys in turn. For example, <Alt, A> means the two keys should be pressed in turn.

Mouse Operation

Action	Description
Select	Press and hold the primary mouse button (left mouse button by default).
Click	Select and release the primary mouse button without moving the pointer.
Double-click	Press the primary mouse button twice continuously and quickly without moving the pointer.
Drag	Press and hold the primary mouse button and move the pointer to a certain position.

Syntax Conventions

Convention	Description
<i>Italics</i>	means new words, terms, or special emphasis. E.g. <i>Getting to know your ADSL Wireless Router.</i>
Boldface	means you can select buttons, checkboxes, or items from screens, menus, or dialog boxes. E.g. Click “OK” to restart
<i>Bold Italics</i>	are samples only and you should enter other names, numbers, or words to substitute.

Environmental Protection

This product has been designed to comply with the requirements on environmental protection. For the proper storage, use and disposal of this product, national laws and regulations must be observed

Preface

Congratulations on your purchase of this ADSL Wireless Router. This ADSL Wireless Router is an ideal solution for SOHO users who require fast Internet access over existing copper wires. This ADSL-based router can provide up to 20Mbps Internet downstream speed and 1Mbps upstream speed. All users in the LAN side allow sharing this high-speed broadband connection with embedded NAT and DHCP server.

Integrated 802.11b/g wireless AP, 4-port 10/100 Mbps Ethernet switch and 1 USB port; it is quick and easy to deploy wireless and wire LAN without spending extra cost of a wireless access point, hub or switch. Especially, the extra USB port offers a fast and convenient connection to the Internet. All LAN users are able to share internal network data, like files, printers, and other networking resources in a blazing speed.

The built-in 802.11 b/g wireless AP enables you to move your computer freely around your living or working environment. The 802.11g technology is an extension of 802.11b, the basis of the majority wireless LANs and being widespread today. 802.11g not only provides data rates up to maximum 54 Mbps, but also is backward compatible with 802.11b.

The ADSL Wireless Router also provides a complete security solution that protects your network from hacker attacks and Internet intruders, as well as filters objectionable Web sites or contents.

With a web-based UI (User Interface), this ADSL Wireless Router is easy to configure and maintain. All functions can be configured with this exclusive, easy and friendly User Interface via web browsers such as Internet Explorer and Netscape Communicator.

This guide contains information about installing and configuring your ADSL Wireless Router. It is designed to guide users through the correct setup procedures for appropriate hardware installation and basic configuration. Later, it shows how to complete advanced configurations to get the best operating performance from this ADSL Wireless Router.

There are 2 models of this router, the different of they are shown below, and the rest is same as each other.

Model	DSL Different
WDR814g	ADSL2+ over POTS
WDR814lg	ADSL2+ over ISDN

1 Introduction

This chapter describes the package contents and provides a list of features and application illustrations of the ADSL Wireless Router.

1.1 About the ADSL Wireless Router

DSL (Digital Subscriber Line) refers to a technology used to increase the data capacity of standard twisted-pair wires that are generally used to connect most households to the phone network. In addition, this technology allows simultaneous voice and high-speed data transmission over a single pair of telephone wires.

There are several kinds of DSL services, each with its own compromises between speed, distance, cost, and reliability. These services are either symmetrical (data flows at the same speed in both directions), or asymmetrical (the downstream capacity is higher than the upstream capacity).

ADSL

Asymmetric Digital Subscriber Line (ADSL), as its name indicates, is an asymmetrical data transmission technology which provides high-speed data transfer over existing telephone or ISDN lines by making good use of the previously unused high-frequency band-width. ADSL provides much higher downstream speed than upstream speed. It is much popular as ordinary users download much more data than what they upload.

ADSL provides a dedicated secure communication between you and the ISP (Internet Service Provider) and the connection is high-speed and always-on.

Ethernet / Fast Ethernet / USB

Ethernet is the most widely-used network access method, especially in a Local Area Network (LAN) and is defined by the IEEE 802.3 standard. Normally, Ethernet is a shared media LAN. All stations on the segment share the total bandwidth, which could be 10Mbps (Ethernet), 100Mbps (Fast Ethernet), or 1000Mbps (Gigabit Ethernet). With a switched Ethernet, each sender and receiver has the full bandwidth.

Fast Ethernet is defined as IEEE 802.3u standard, a high-speed version of Ethernet with 100Mbps transmission rate.

USB (Universal Serial Bus) is a data communication standard which allows the PC/desktop to detect new devices such as printers, joysticks, keyboards, mice, adapters, storage devices, audio devices, digital cameras and things with this technology. The advantage of USB is to replace different types of serial and parallel port connectors with one standardized plug and port combination with the data transfer rate up to 12Mbps. Also low-power devices can draw power from USB and don't require an extra adapter. Before you use this connector, you may need to install the USB driver first.

Wireless LAN

Wireless Local Area Network systems (WLANs) transmit and receive data over the air by using radio frequency (RF). This offers some advantages like mobility, ease of installation, and scalability over traditional wired systems.

Mobility: WLANs combine data connectivity with user mobility. This provides users with access to network anywhere in their organization. For example, users can roam from a conference room to their office without being disconnected from the LAN. This is impossible with wired networks.

Ease of Installation: Eliminating the need to deploy network cables in walls and ceilings, installing WLANs is easy for novice and expert users alike.

Scalability: WLAN topologies are easy to change in various ways from peer-to-peer networks for a small group of users to full infrastructure networks for hundreds of users roaming over a broad area.

Wireless LAN is suitable for difficult-to-wire and frequently changing environments. It's also an ideal solution for mobile workers to access network resource and for setting a temporary LAN when necessary.

Wireless LANs can be set as "Ad-hoc" network and "Infrastructure" network. Unlike the "Ad-hoc network", where users on the LAN send data directly to each other, the "Infrastructure" network includes an access point and users on the "Infrastructure" network send data to that dedicated access point. ADSL Wireless Router uses "Infrastructure" network as Wireless LANs. Each wireless LAN PC within the range of the access point can communicate with other wireless LAN PCs within the range.

Firewall

DoS is an abbreviation for Denial of Service. This occurs when a computer or network is overwhelmed to the point that it can no longer function normally. For example, a hacker may use fake IP addresses to accumulate numbers connections in orders to flood the server he wants to attack. The way TCP works is that a SYN packet is sent to the server from the client. After the server receives the SYN packet, a SYN-ACK is sent back to client. The server will then wait for the reply from the SYN-ACK. If the hacker sent hundreds or thousands of SYN packets to the server with bogus IP addresses, the server allocates computer and memory resources to establishing a connection since the server does not know a legitimate SYN message from a bogus message. By flooding the server with a large volume of requests, the server's maximum capacity can be used by these bogus and useless connection attempts.

SPI is an acronym for Stateful Packet Inspection. The SPI engine examines not just the headers of the packet, but also the packet content. It can then determine more about the packet than just its source and destination information. Moreover, stateful inspection firewalls also close off ports until a connection to the specific port is requested.

1.2 Contents of the ADSL Wireless Router Package

After carefully unpacking the shipping carton, check the contents listed below.

- n 1 Aolynk ADLS2+ router
- n 1 Power adaptor
- n 1 Telephone cables
- n 1 Ethernet cable
- n 1 USB cable
- n 2 Screw and anchor
- n 1 Quick Start Manual
- n 1 Driver & Manual CD

- n 1 Quality card

1.3 Features of the ADSL Wireless Router

Your ADSL Wireless Router contains the following features which done the absolutely excellent work for network connections.

- n Asymmetrical data rates of up to 8Mbps downstream and 832kbps upstream.
- n Supports ITU G.dmt, ITU G.lite, ANSI T1.413 issue 2, ADSL2 and ADSL2+ standards.
- n Allows multiple users to access the Internet at the same time by providing maximum Internet utilization to multiple users sharing a single public IP Address.
- n Allows users on Ethernet LAN and Wireless LAN to transfer data to each other through wireless-to-wire Bridge.
- n Provides wireless access roaming, best access point selection, loading balance, network traffic filtering included in wireless roaming function.
- n Provides 64bits/128bits key WEP (Wired Equivalent Privacy) wireless data encryption to secure wireless communication.
- n Fully supports 802.11 open and shared key authentications.
- n Integrates four 10/100BASE-T/TX auto-sensing switch ports.
- n Uses NAT to allow your entire network's PCs to connect to the Internet using only one (purchased) IP address.
- n Supports PPPoE enabling users to seamlessly connect to ISPs with the familiar "dial-up" connection interface.
- n Built-in web-based user interface for easy configuration and management through common web browsers such as Netscape Communication 6.0 or later and Internet Explorer 5.0 or later.
- n Built-in firewall to protect your PCs from outside intruders (NAT).
- n Supports DHCP client to receive both a dynamic IP Address and a fixed IP Address from ISP.
- n Built-in DHCP server to automatically assign and manage LAN IP addresses.
- n Allow administrators to block specific internal users from accessing specified applications or services.
- n Allows external Internet users to access information from the internal target host by setting the Virtual Server.
- n Provides unrestricted two-way communication between one PC on your LAN and certain Internet services such as conferencing, video and gaming applications.
- n Enhances routing performance by using Dynamic and Static routing settings.
- n Compatible with all popular Internet applications.

2 Hardware Installation & Setup

This chapter provides information about your ADSL Wireless Router's physical features and gives step-by-step installation instructions for hardware installation and software configuration.

2.1 Rear Panel & Connections

The following figures show the rear view of the ADSL Wireless Router and illustrate how the cables connect to the interfaces on the rear panel.



- Step1** Plug one end of the ADSL line (Standard phone line) into the ADSL port, the other into the wall jack that is connected to the ADSL service.
- Step2** Connect the Ethernet NIC (Network Interface Card) port of a PC to one of the LAN Ports.
- Step3** Connect the external power supply to the ADSL Wireless Router.
- Step4** The Reset button is used to reboot and re-initialize the device (press once quickly), or for clearing configuration settings back to factory default values (press for longer than 3 seconds).

& Note:

*If you are Macintosh users, please refer to **Chapter 6 Macintosh Setup** for more*

detailed information about configuring TCP/IP, hardware installation and so on.

2.2 Front Panel LEDs

The following figure shows the front view of the ADSL Wireless Router. The LEDs on the front panel indicate the status of the unit. You can easily view the operation of your High-Performance Wireless Router from this panel.

& Note:

Please refer to the model on your hand to find proper description.



The LEDs on the front panel indicate the status of the unit. You can easily view the operation of your ADSL Wireless Router from this panel.

LED	Status	Description
Power	ON	Power has been switched on and is working normally
	OFF	Power is switched off or fails.
Diag	-	For factory test only
Link	ON	ADSL loop is brought UP.
	Blinking	Startup.
	OFF	ADSL loop is down.
Act	Blinking	Data is being transmitted or received through ADSL.
	OFF	No data transmission activities present on the link.
Wireless	ON	Wireless connection established
	OFF	Wireless function disabled
USB	ON	USB connection established
	OFF	No USB cable connected

LED	Status	Description
	ON	Ethernet link is up.
LAN0/1/2/3	Blinking	Ethernet interface is transmitting or receiving data.
	OFF	No link is up.

2.3 POTS Splitter

If your ISP offers ADSL services and *POTS* (*plain old telephone service*) in the same telephone line, you can connect and use ADSL and ordinary phone services at the same time by using a *POTS Splitter*. The following figure shows how to connect a POTS Splitter into your ADSL connection. (A POTS splitter is likely to be provided by your ISP)

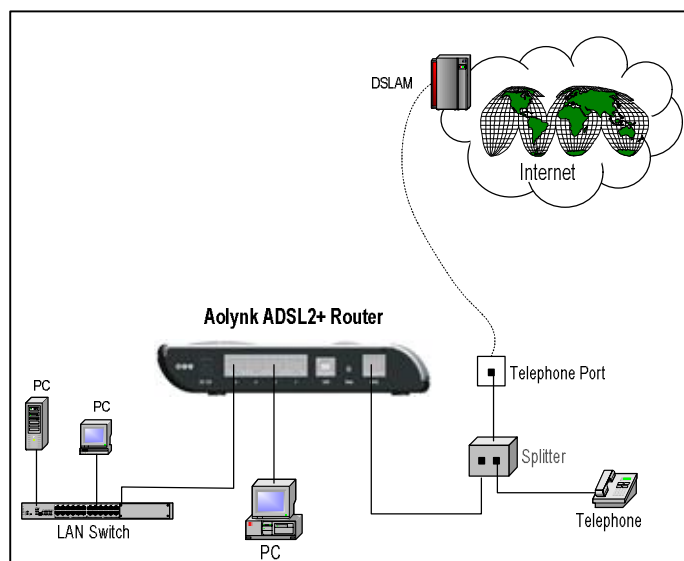

2.4 System Requirements and Setup

To connect to the Internet, an external ADSL or Cable modem and an Internet access account from an ISP is required. In order to operate with the ADSL Wireless Router, each PC that is to be connected to the ADSL Wireless Router should have the following things installed:

- n Ethernet NIC (Network Interface Card: a 10Base-T or 10/100Base-T/TX Ethernet card), or wireless client card for wireless connection.
- n Standard twisted-pair Ethernet cable (UTP network cable) with RJ-45 connectors. Or the USB cable.
- n System OS: Windows 95/98, Windows NT4.0, Windows 2000/XP, or other OS with web browser installed.
- n TCP/IP network protocol.
- n Web browser, such as Microsoft Internet Explorer 5.0 or later, or Netscape Navigator 6.0 or later.

2.4.1 Installing the TCP/IP Protocol

If you are not sure whether the TCP/IP Protocol has been installed, follow these steps to check, and if necessary, install TCP/IP onto your PCs.

Step1 Click the **“Start”** button. Choose **“Settings”**, then **“Control Panel”**. Double-click the **“Network”** icon. Your Network window should appear as follows:



Step2 Select the **“Configuration”** tab.

& Important Note:

Settings for Windows 2000/XP and Windows 98/ME/NT might differ slightly. See the following for reference.

Click the **“Local Area Connection”** icon on the lower right hand side of your desktop screen.



In the “**Local Area Connection Status**” window, click the “**Properties**” button then your Network window will appear.



Step3 Check whether the TCP/IP Protocol has already been installed onto your computer's Ethernet card. Note that TCP/IP Protocol can be installed for a computer's Dial-Up Adapter as well as for the Ethernet card.

- If yes, go to step 7.
- If no, click the “Add” button.

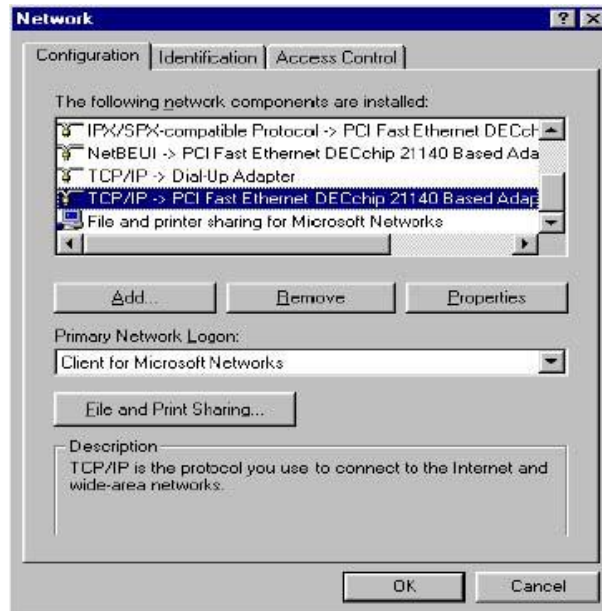

Step4 Double-click **“Protocol”** in the Select Network Component Type or highlight **“Protocol”** then click **“Add”**.

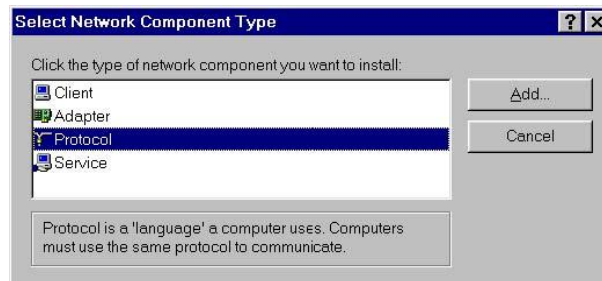

Step5 Highlight **“Microsoft”** under the list of manufacturers. Double-click **“TCP/IP”** from the list on the right or highlight **“TCP/IP”** then click **“OK”** to install TCP/IP.

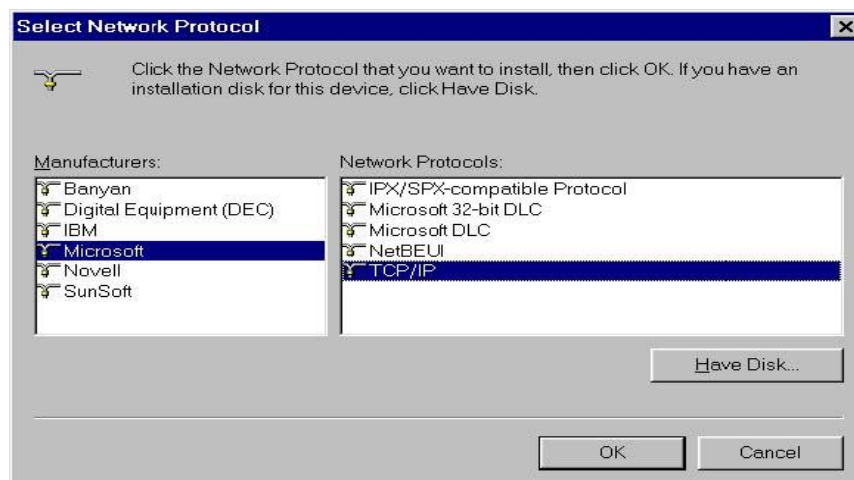

Step6 After a few seconds, you will be returned to the Network window. The TCP/IP Protocol should now be on the list of installed network components (see 3 above).

- Step7** Click the **“Properties”** button. The TCP/IP Properties window consists of several tabs. Choose the **“IP Address”** tab.
- Step8** Select **“Obtain an IP address automatically”**. Click **“OK”**. Restart your PC to complete the TCP/IP installation.

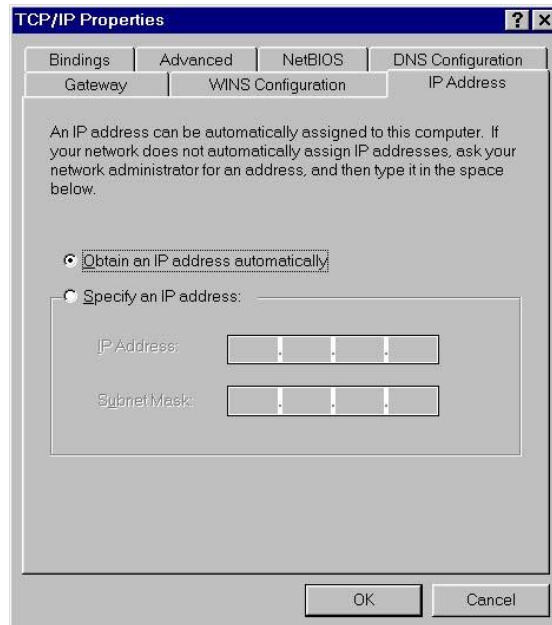

2.4.2 Fixed IP Addresses Configuration

Fixed IP addresses may be assigned to network devices for many reasons, such as the server PCs or printers which are consistently accessed by multiple users. To set up computers with fixed IP Addresses, go to the **“IP Address”** tab of the **“TCP/IP Properties”** window as shown above.

- Step1** Select **“Specify an IP address”** and enter **“192.168.1.xxx”** in the **“IP Address”** location (where xxx is a number between 2 and 254 used by the High-Performance Wireless Router to identify each computer), and the default **“Subnet Mask” 255.255.255.0**. Note that no two computers on the same LAN can have the same IP address.

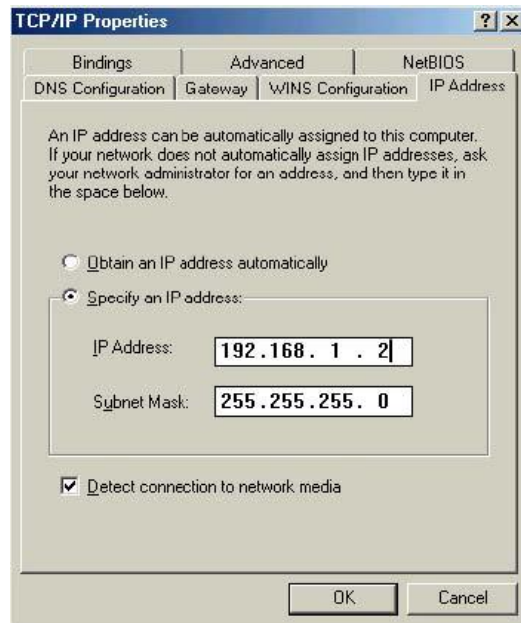

Step2 Click on the “**DNS Configuration**” tab and select “**Enable DNS**”. Enter the “**DNS IP Address**” obtained from your ISP in the “**Server Search Order**” location. Then click the “**Add**” button.

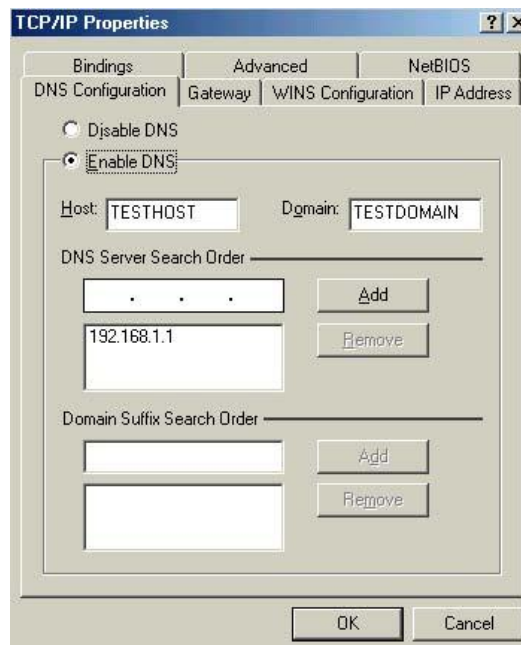

Step3 Click on the “**Gateway**” tab and enter the High-Performance Wireless Router’s default gateway value **192.168.1.1** in the “**New gateway**” field, then click “**Add**” Button.

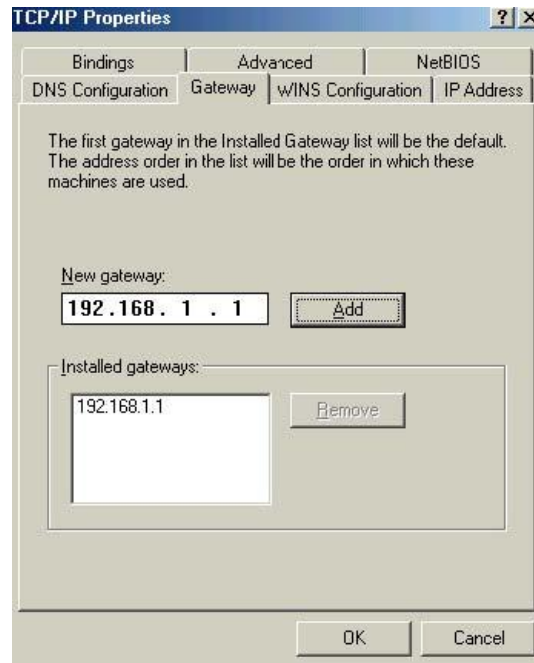

Step4 Click “OK”. Restart your PC to complete the TCP/IP installation.

2.4.3 Installing the USB driver

Before you start to enjoy the ADSL Wireless Router, you might need to install the USB driver first. Once you install the driver, you won't need to install again and you can use the USB port to surf the web. Please follow these steps to install the driver.

Step1 Plug the USB connectors into both your PC's USB port and the ADSL Wireless Router's USB port.

The operating system will auto-detect the new device plugged into the PC, and will pop up windows like the following:





Step2 Select “Install from a list or specific location” and click “Next”.

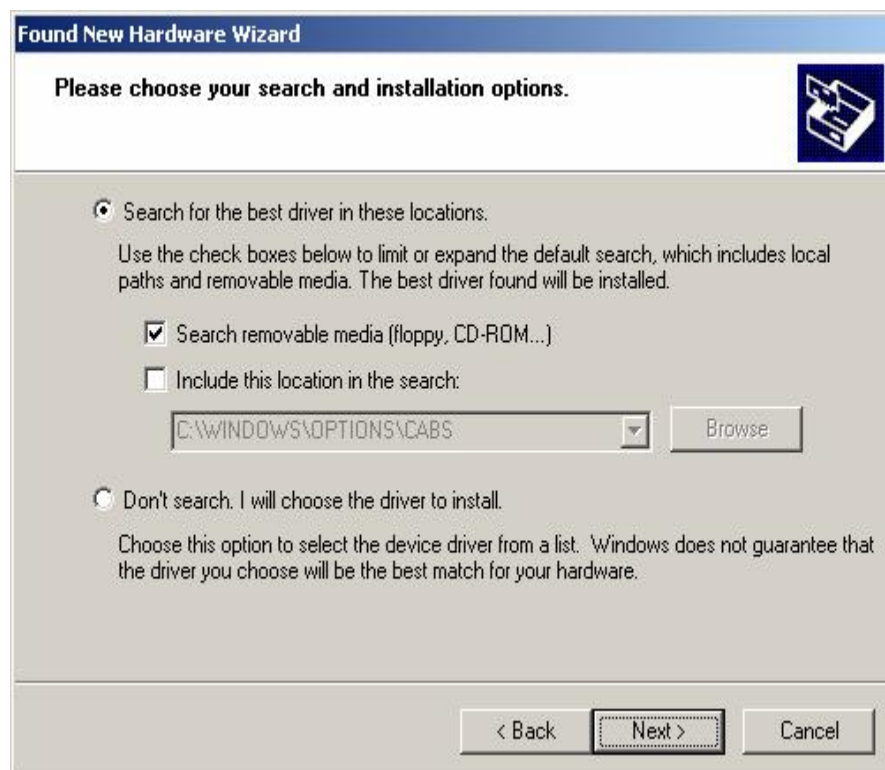

Step3 Select the “Search for the best driver in these locations”, and check the

“CD-ROM”. Notice: Before you check this item, please confirm that you have put the installer CD into your CD-ROM.

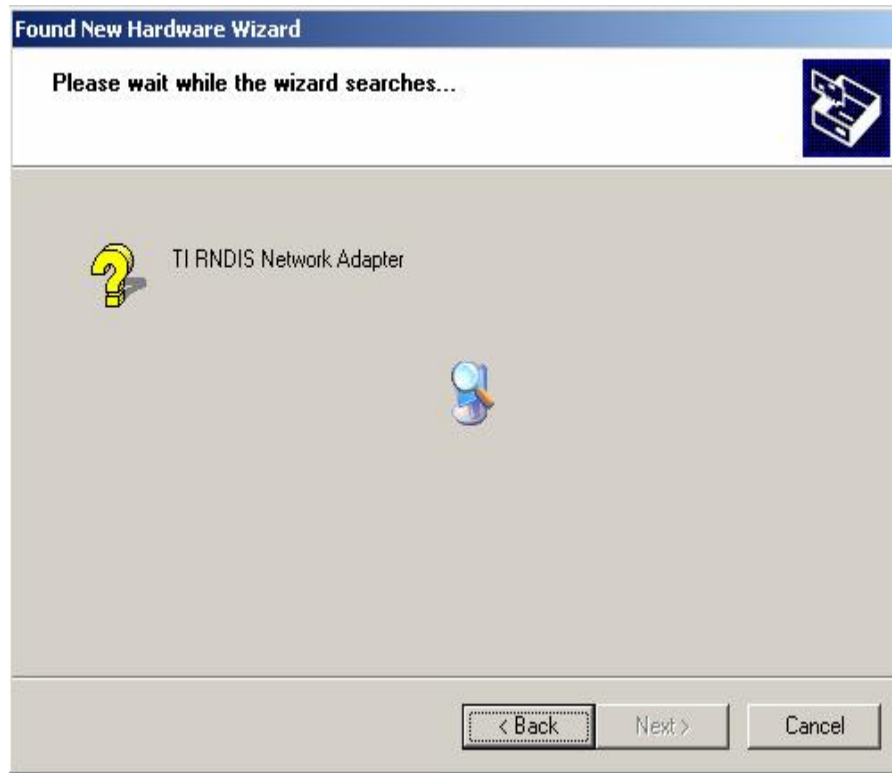

The driver now is searched and installed.



Congratulation! Now you have installed the USB driver. Please click the “**Finish**”

button to continue. This means you can enjoy the world by using the ADSL Wireless Router's USB port with this PC at anytime.

3 Internet Access

This chapter describes the procedures necessary to configure the basic functions and begin using your ADSL Wireless Router. If you follow these procedures correctly, there should be no problem in accessing the Internet via your ADSL Wireless Router.

3.1 Prepare your network

In order to allow quick referencing when setting up your ADSL Wireless Router, it is suggested you fill the table below with necessary information. This should be supplied by your ISP.

Provided by some ISPs	Host Name: Domain Name:
Internet Connected mode:	DHCP or Static(1483 bridged) IPoA(1483 Routed) PPPoE PPPoA Bridged

IP address given by ISP:	Dynamic Static : IP Address: Subnet Mask: Default Gateway: DNS Server Primary: DNS Server Secondary: DNS Server Third:
Frame type:	LLC VC
QoS type:	UBR CBR Pcr Rate: _____ cps VBR Pcr Rate: _____ cps Scr Rate: _____ cps
PPPoE/PPPoA setting	Username: _____ Password: _____ Connected type Connect on Demand Idle Time: _____ minutes. Keep Alive Redial Period: _____ Seconds.
Virtual Circuit Settings:	VPI: VCI:

3.2 Web-based User Interface

This ADSL Wireless Router is designed to use a Web-based User Interface for configuration. Open your web browser and type <http://192.168.1.1> in the browser's *address box*. This address is the factory set IP Address of your ADSL Wireless Router. Press "**Enter**".

The "**Username and Password Required**" prompt box will appear. Both Username

and Password are “**admin**” (default password) by default. Click “**OK**”. The configuration screen will then appear.



3.3 Quick Start this ADSL Wireless Router

The ADSL Wireless Router implements the “Quick Start” function to let you connect to your ISP quickly and easily. There are two connection types shown here, one is the 1483 bridge mode and the other is the PPPoE mode. Choose your connection mode and fill out needed information while connecting to your ISP. The 1483 bridge mode has two selections, one is the “Obtain IP address automatically” and the other is the “static IP address”. The values shown in the screen following should have been correctly configured when the router are successfully installed and set up.

Connection Type

RFC1483 Bridge

It is a zero configuration of this device while your PC shipped a PPPoE dial client.

PPPoE Login

This device would dial PPPoE instead of your PC, you should fill username and password here.

IP Setting

Obtain an IP Address Automatically

Use the following IP Address:

Internet IP Address:	<input type="text" value="0"/>	.	<input type="text" value="0"/>	.	<input type="text" value="0"/>	.	<input type="text" value="0"/>
Subnet Mask:	<input type="text" value="0"/>	.	<input type="text" value="0"/>	.	<input type="text" value="0"/>	.	<input type="text" value="0"/>
Gateway:	<input type="text" value="0"/>	.	<input type="text" value="0"/>	.	<input type="text" value="0"/>	.	<input type="text" value="0"/>
Primary DNS:	<input type="text" value="0"/>	.	<input type="text" value="0"/>	.	<input type="text" value="0"/>	.	<input type="text" value="0"/>
Secondary DNS:	<input type="text" value="0"/>	.	<input type="text" value="0"/>	.	<input type="text" value="0"/>	.	<input type="text" value="0"/>

Connection Type

RFC1483 Bridge

It is a zero configuration of this device while your PC shipped a PPPoE dial client.

PPPoE Login

This device would dial PPPoE instead of your PC, you should fill username and password here.

PPPoE Setting

User Name:	<input type="text" value="WDR814g"/>
Password:	<input type="password" value="••••••"/>
Retype Password:	<input type="password" value="••••••"/>

3.4 WAN Setup

3.4.1 Internet Connection Setup

1. PVC Connection

The ADSL Wireless Router implements **8** sets of PVC connections for you to configure different connections between you and the ISP. You can select which channel you want and click “**Enable Now**” to enable this connection. Next you have to configure the following settings to finish the internet connection setup.

Internet Connection Setting

PVC Connection:	<input type="text" value="1"/>														
Enable Now:	<input checked="" type="checkbox"/>														
Internet Connection Type:	<input type="text" value="DHCP or Static"/>														
VC Settings:	<table> <tr> <td>Multiplexing:</td> <td><input type="text" value="PPPoE"/></td> </tr> <tr> <td>QoS Type:</td> <td><input type="text" value="PPPoA"/></td> </tr> <tr> <td>Pcr Rate:</td> <td><input type="text" value="0"/> cps</td> </tr> <tr> <td>Scr Rate:</td> <td><input type="text" value="0"/> cps</td> </tr> <tr> <td>Autodetect:</td> <td><input checked="" type="radio"/> Enable <input type="radio"/> Disable</td> </tr> <tr> <td>Virtual Circuit:</td> <td>VPI <input type="text" value="8"/> (Range 0~255)</td> </tr> <tr> <td></td> <td>VCI <input type="text" value="35"/> (Range 1~65535)</td> </tr> </table>	Multiplexing:	<input type="text" value="PPPoE"/>	QoS Type:	<input type="text" value="PPPoA"/>	Pcr Rate:	<input type="text" value="0"/> cps	Scr Rate:	<input type="text" value="0"/> cps	Autodetect:	<input checked="" type="radio"/> Enable <input type="radio"/> Disable	Virtual Circuit:	VPI <input type="text" value="8"/> (Range 0~255)		VCI <input type="text" value="35"/> (Range 1~65535)
Multiplexing:	<input type="text" value="PPPoE"/>														
QoS Type:	<input type="text" value="PPPoA"/>														
Pcr Rate:	<input type="text" value="0"/> cps														
Scr Rate:	<input type="text" value="0"/> cps														
Autodetect:	<input checked="" type="radio"/> Enable <input type="radio"/> Disable														
Virtual Circuit:	VPI <input type="text" value="8"/> (Range 0~255)														
	VCI <input type="text" value="35"/> (Range 1~65535)														

2. ADSL Connection Type:

There are five options for WAN connection types, DHCP or Static IP (1483 bridged), IPoA (1483 Routed), PPPoE, PPPoA and bridge mode.

DHCP or Static, IPoA, PPPoE, and PPPoA are different *connection modes* that use different protocols to make the initial session between your ADSL Wireless Router and the ISP's equipment.

The connection type you need to choose is dependent upon the settings assigned by your ISP. It varies with ISPs as well as the service you applied for. If you are not sure which connection type you should use, contact your ISP to obtain the correct information.

3. DHCP or Static mode

The DHCP connection type is the default setting of this ADSL Wireless Router. Leave this setting on the column according to the following conditions: Your ISP uses DHCP to assign IP address when you connect to your ISP.

Some ISP might distribute unique IP address for you to access the internet. In this way, you have to enter the IP address, subnet mask, Gateway and DNS provided by the ISP.

IP Settings

- Obtain an IP Address Automatically
 Use the following IP Address:

Internet IP Address:	<input type="text"/>	.	<input type="text"/>	.	<input type="text"/>	.	<input type="text"/>
Subnet Mask:	<input type="text"/>	.	<input type="text"/>	.	<input type="text"/>	.	<input type="text"/>
Gateway:	<input type="text"/>	.	<input type="text"/>	.	<input type="text"/>	.	<input type="text"/>
Primary DNS:	<input type="text"/>	.	<input type="text"/>	.	<input type="text"/>	.	<input type="text"/>
Secondary DNS:	<input type="text"/>	.	<input type="text"/>	.	<input type="text"/>	.	<input type="text"/>

Internet IP Address:	Enter the IP address provided by your ISP.
Subnet Mask:	Enter the subnet mask values provided by your ISP.
Gateway:	Your ISP will provide you with the Default Gateway IP Address.
Domain Name Server (DNS):	Your ISP will provide you with at least one DNS IP Address. Multiple DNS IP settings are common. The first available DNS entry is used in most cases.

4. PPPoE (Point-to-Point Protocol over Ethernet)

Choose this setting according to your ISP to use PPPoE as the connection mode. You can find more information on RFC 2516.

PPPoE is a dial-up connection type provided by some ISPs. It is a cost-effective way for a user to access the internet using this connection type. If your ISP provides PPPoE connectivity, you should choose this item from the drop-down list. Note: if you select PPPoE mode, please remove any existing PPPoE applications on any PCs on your LAN.

PPPoE Settings

User Name:

Password:

Connect on Demand: Max Idle Time Min.

Keep Alive: Redial Period Sec.

User Name: Enter the user name your ISP provides you.

Password: Enter the password your ISP provides you.

Connect on Demand: It is a utility used to trigger the PPPoE session when there is a packet being sent through the WAN port while it is on disconnected situation. Check the radio button to make this function active, and then you must enter the number of minutes you wish the network to remain idle before disconnection occurs in the "Max Idle Time" location.

Keep Alive: This function keeps your PPPoE connection enabled even if it remains idle. However, in some situation, PPPoE session cannot be established immediately after disconnection. This is because the system on the ISP's site may need a little time to restore itself. You may need to check with your ISP to obtain details of how long you need to wait before re-establish the PPPoE session. Enter this information in the "Redial Period" field.

5. PPPoA (Point-to-Point Protocol over ATM)

Choose this setting according to your ISP used PPPoA as connection mode. You can find more information on RFC 2684.

PPPoA Settings

User Name:

Password:

Connect on Demand: Max Idle Time Min.

Keep Alive: Redial Period Sec.

User Name: Enter the user name your ISP provides you.

Password: Enter the password your ISP provides you.

Connect on Demand: It is a utility used to trigger the PPPoA session when there is a packet being sent through the WAN port while it is on disconnected situation. Check the radio button to make this function active, and then you must enter the number of minutes you wish the network to remain idle before disconnection occurs in the "Max Idle Time" location.

Keep Alive: This function keeps your PPPoA connection enable even if

it remains idle. However, in some situation, PPPoA session cannot be established immediately after disconnection. This is because the system on the ISP's site may need a little time to restore itself. You may need to check with your ISP to obtain detail of how long you need to wait before re-establish the PPPoA session. Enter this information in the "Redial Period" field.

6. Bridged mode

If you choose this mode, this ADSL Wireless Router will act as a layer 2 bridge. It only forwards your packets to other routers.

7. VC (Virtual Circuit) Setting

There are two framing types LLC or VC for you to click. This selection depends on your ISP's implementation.

Also there are three types of QoS mode for you to select, UBR, CBR and VBR.

If you select UBR, you don't have to fill the Pcr rate. Only CBR and VBR mode need the Pcr rate value. If the mode is VBR, then you also need to fill the Scr rate.

The ADSL Wireless Router implements "**Autodetect**" function for you to connect to the ISP. If the ISP provides unique VPI and VCI value, then you should click the **Disable** item and input the VPI and VCI values provided by your ISP.

VC Settings:

Multiplexing: LLC VC

QoS Type:

Pcr Rate: cps

Scr Rate: cps

Autodetect: Enable Disable

Virtual Circuit: VPI (Range 0~255)

VCI (Range 1~65535)

8. Optional Setting

Some ISP might need the host name, domain name and MTU data size to recognize the connection. MTU is the Maximum Transmission Unit. It specifies the largest packet size permitted for Internet transmission. Keep the default setting, **Auto**, to have the Router select the best MTU for your Internet connection. To specify an MTU size, select **Manual**, and enter the value desired (default is **1400**). You should leave this value in the range 576 to 1492.

Optional Settings (required by some ISPs)

Host Name:

Domain Name:

MTU:

Size:

When you have properly configured the Setup page, click “[Save Settings](#)”. You can now test to see if the settings are all correct by attempting to connect to the Internet.

A rectangular button with a light gray background and a thin black border. The text "Save Settings" is centered in a blue, sans-serif font.A rectangular button with a light gray background and a thin black border. The text "Undo" is centered in a blue, sans-serif font.

& Note:

You must click “[Save Settings](#)” to apply all the configurations. If you would like to reset the settings, just click “[Undo](#)” to refresh the web page.

3.4.2 DDNS Setup

“**DDNS**” is an acronym for Dynamic Domain Name Service. Whenever you set up web servers, mail servers, or sometimes ftp servers, you need “**Domain Name**” to help Internet users reach your servers easily.

Internet actually runs on IP Addresses which are in numerical order, for example “66.37.215.53”. These IP addresses identify the location of each device connected to Internet. However, the human brain cannot easily remember this numbering system, so a system that allocates domain name such as “[www.dyndns.org](#)” provides an easier method. If you type “66.37.215.53” or “[www.dyndns.org](#)” in the web browser’s address bar, the browser will show the same web page. This is because both input relate to the same web server. The “**Domain Name Server**” used to manage the Internet will translate “[www.dyndns.org](#)” into the IP address “66.37.215.53” in order to allow your browser to find the web server and display the correct web page in your browser.

If your “WAN Connection Type” is “PPPoE” with dynamic IP address assigned by the ISP, it will cause an error when you set up the public computer servers in your LAN side PCs. Internet users may not be able to reach your servers because your WAN side IP address may change each time you initiate the connection to your ISP. The DDNS function will help to map your IP address to your domain name when your ISP assigns a new dynamic IP Address.

Note that this DDNS function acts as the client appliance of DDNS service and is only able to be used in conjunction with the service provided by DynDNS.org. Before you begin using this function, you will need to apply to DynDNS.org to be able to use the service. Please visit [www.dyndns.org](#) for further information.

DDNS Service: 

E-mail Address:

Password:

Domain Name:

DDNS Connect IP Address: 0.0.0.0

Status:

DDNS Service:	Check the "Enable" option if you wish to activate this function.
Username:	After you have applied for the DDNS service from DynDNS.org, you will be issued with a Username. Enter this username in the "Username" field.
Password:	Enter the Password issued by DynDNS.org
Host Name:	DynDNS.org will provide you with a Host Name. Enter this name in the "Host Name" field.
IP Address	It displays the IP Address currently assigned by your ISP.
Status:	This displays the current status of the DDNS function.

3.4.3 NTP Setup

Select the time zone for your location. If your location experiences daylight savings, leave the checkmark in the box next to *Automatically adjust clock for daylight saving changes*.

(GMT-08:00) Pacific Time (USA & Canada) ▼

Automatically adjust clock for daylight saving changes



3.5 LAN Setup

3.5.1 LAN IP setting & DHCP setting

This is the Router IP Address and Subnet Mask as seen on the Local Area Network. The default value is 192.168.1.1 for IP Address and 255.255.255.0 for Subnet Mask.

Router LAN IP Setting

Local IP Address: . . .
 Subnet Mask: ▼

This ADSL Wireless Router also implements DHCP server function to dispatch LAN IP addresses to the clients connected to the router.

Network DHCP Server Setting

Local DHCP Server: Enable Disable DHCP Relay

DHCP Server: . . .

Starting IP Address: 192.168.1.

DHCP Assigned User Number:

Client Lease Time: minutes (0 means one day)

Static DNS 1: . . .

Static DNS 2: . . .

Static DNS 3: . . .

WINS: . . .

DHCP Server:	Keep the default, Enable, to enable the Router' DHCP server option. If you already have a DHCP server on your network or you do not want a DHCP server, then select Disable.
Starting IP Address:	Enter a numerical value for the DHCP server to start with when issuing IP addresses. Do not start with 192.168.1.1 (the IP address of the Router).
Maximum Number of DHCP Users	Enter the maximum number of PCs that you want the DHCP server to assign IP addresses to. The absolute maximum is 253--possible if 192.168.1.2 is your starting IP address.
Client Lease Time	The Client Lease Time is the amount of time a network user will be allowed to connect to the Router with their current dynamic IP address. Enter the amount of time, in minutes, that the user will be "leased" this dynamic IP address.
Static DNS 1-3	The Domain Name System (DNS) is how the Internet translates domain or website names into Internet addresses or URLs. Your ISP will provide you with at least one DNS Server IP Address. If you wish to utilize another, enter that IP Address in one of these fields. You can enter up to three DNS Server IP Addresses here. The Router will utilize these for quicker access to functioning DNS servers.
WINS	The Windows Internet Naming Service (WINS) manages each PC's interaction with the Internet. If you use a WINS server, enter that server's IP Address here. Otherwise, leave this blank.

3.5.2 Routing Setting

To make the internet connection more secure, the NAT operating mode is strongly recommended to be enabled. Because the hacker might directly enter your PC

without efforts by the IP address you exposed on the internet.

Operating Mode

NAT

Enabled Disabled

Dynamic Routing enables the Router to automatically adjust to physical changes in the network's layout and exchange routing tables with other routers. The Router determines the network packets' route based on the number of hops between the source and destination.

Dynamic Routing

RIP:

Enable Disable

Transmit RIP Version:

RIP1

Receive RIP Version:

RIP1

Static Routing

Select set number:

1

Delete This Entry

Destination IP Address:

0 . 0 . 0 . 0

Subnet Mask:

0 . 0 . 0 . 0

Gateway:

0 . 0 . 0 . 0

Hop Count:

1

Show Routing Table

To set up a static route between the Router and another network, select a number from the *Static Routing* drop-down list. (A static route is a pre-determined pathway that network information must travel to reach a specific host or network.) Enter the following data:

- n **Destination IP Address** — The Destination IP Address is the address of the network or host to which you want to assign a static route.
- n **Subnet Mask** — The Subnet Mask determines which portion of an IP address is the network portion, and which portion is the host portion.
- n **Gateway** — This is the IP address of the gateway device that allows for contact between the Router and the network or host.
- n **Hop Count** — This is the rip protocol implementation parameter.

Depending on where the Destination IP Address is located, select **LAN & Wireless** or **WAN** from the *Interface* drop-down menu.

The Static Routing feature allows PCs that are connected to the Wireless Security Router, either directly or through a hub/switch (in the immediate LAN), to communicate with other PCs in the respective LAN segment which are connected to the Wireless Security Router through another router (destination LAN). Up to 20 route entries may be input into the Wireless Security Router. The diagram below gives an example of the physical connections required to use Static Routing.

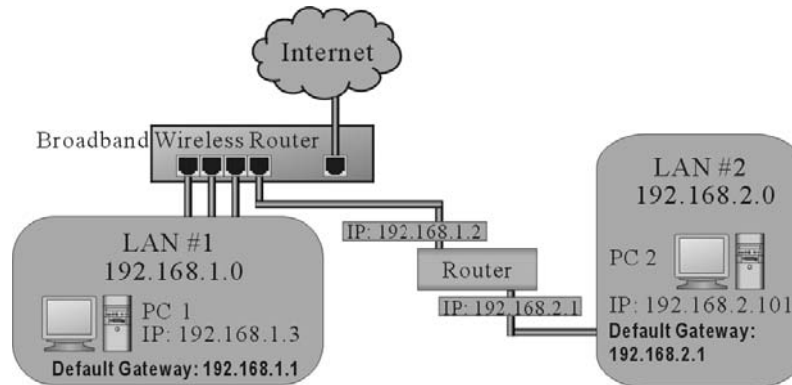

In the above diagram, PC2 in LAN#2 is connected to the Wireless Security Router via another router while PC1 in LAN#1 is connected to the Wireless Security Router directly. Without configuring the Static Routing function, the two PCs would not be able to communicate with each other.

3.6 Wireless Setup

Wireless Network Mode:

SSID:

Wireless Channel:

Wireless SSID Broadcast: Enable Disable

Wireless Network Mode: The ADSL Wireless Router can reach the connection speed of 54Mbps over the 802.11g wireless standard. Also it implements 802.11b for users using early version of wireless. If you have Wireless-G and 802.11b devices in your network, then keep the default setting, Mixed. If you have only Wireless-G devices, select G-Only. If you want to disable wireless networking, select Disable. If you would like to limit your network to only 802.11b devices, then select B-Only.

SSID: As the acronym for Basic Service Set Identifier, BSSID is the unique name shared among all clients and Wireless Broadband Router in the same wireless network. The BSSID must be identical for all points and must not exceed 32 characters.

Channel: Select the appropriate channel number from the drop-down. The permissible channels are different from Regulatory Domains. Make sure that all nodes in the same wireless LAN network use the same channel, or the channel usage is automatic when a connection between a client and an access point is made.

Wireless SSID Broadcast: When wireless clients survey the local area for wireless networks to associate with, they will detect the SSID broadcast by the Router. To broadcast the Router SSID, keep the default setting, Enable. If you do not want to broadcast the Router SSID, then select Disable.

3.7 Advanced Wireless Setting

Security Mode:

Default Transmit Key: 1 2 3 4

WEP Encryption:

Passphrase:

Key 1:

Key 2:

Key 3:

Key 4:

Authentication Type: (Default: Auto)

Control TX Rate: (Default: Auto)

Beacon Interval: (Default: 100, Milliseconds, Range: 1 - 65535)

DTIM Interval: (Default: 1, Range: 1 - 255)

Fragmentation Threshold: (Default: 2346, Range: 256 - 2346)

RTS Threshold: (Default: 2347, Range: 0 - 2347)

WEP: As the acronym for Wired Equivalent Privacy, WEP is

	<p>an encryption mechanism used to protect your wireless data communications. WEP uses a combination of 64-bit/128-bit keys to encrypt data that is transmitted between all points in a wireless network to insure data security. To code/decode the data transmission, all points must use the identical key. To make the WEP encryption active or inactive, select "Mandatory" or "Disable".</p>
WEP Key Setting:	<p>As the WEP is active, click the button of "WEP Key Setting" to go to the setting page. Select "64Bit" or "128Bit" encryption algorithm from the drop-down list. There are two ways to generate WEP key:</p> <p>Passphrase Enter an alphanumeric text string in this column then click "Generate" button, and four 64-bit encryption keys will be created automatically. Note that only one 128-bit key will be generated in 128-bit encryption mode.</p> <p>Manually You may need to enter the WEP key manually in case to join the existing wireless network. However, if not, the Pass phrase method is recommended. If you are not sure which way to use, check with your network administrator.</p> <p>Default Transmit Key Select one of the four keys to be the encryption key you are going to use in the wireless network. Make sure that all the points in a same wireless network have the same encryption key.</p>
Beacon Interval:	<p>It's the signal sent periodically by wireless access point to provide synchronization among the stations in wireless LAN.</p>
RTS Threshold:	<p>RTS packet is use to account for potential hidden stations. This feature allows you to set the size of RTS packet.</p>
Fragmentation Threshold:	<p>If the length of data frame needing transmission exceeds the fragmentation threshold you set in the column, the data frame will be fragmented. If there is significant interference or high utilization in your wireless network, a smaller fragmentation value can increase the reliability of transmission. However, it is more efficient to set a large fragment size.</p>
DTIM Interval:	<p>DTIM is the acronym of Delivery Traffic Indication Message. It determines how often the MAC Layer forwards multicast traffic.</p>
Basic Rate:	<p>Leave "Mixed" as default setting to compatible with different wireless standard or select other rates you wish to use to connect with specific wireless standard devices.</p>
Transmission Rate:	<p>Leave "Default" setting or select other speed you wish to use.</p>
Preamble Type:	<p>Leave "Dynamic" as default setting or select other type to compatible with special settings your client devices use.</p>

Authentication Type: Select either Open System or Share Key as authentication type. If you are not sure, select both.

3.8 Advanced Applications

This chapter provides information on how to set up and use the advanced functions of your ADSL Wireless Router.

3.9 Security

This selection includes two settings: Access Policy, Firewall.

3.9.1 Access Policy

The settings page allows you to configure Internet Access Policy, providing superior security for your network environment.

Internet Access Policy: 1 () Delete Summary

Status: Enable Disable

Enter Policy Name:

PCs: Edit List of PCs

Deny Allow **Internet access during selected days and hours.**

Days Everyday
 Sun Mon Tue Wed
 Thu Fri Sat

Hours 24 Hours
 From : To :

Blocked Services Add/Edit Service

<input type="text" value="None"/>	None	~	None
<input type="text" value="None"/>	None	~	None

Website Blocking by URL Address

<input type="text"/>	<input type="text"/>
<input type="text"/>	<input type="text"/>

Website Blocking by Keyword

<input type="text"/>	<input type="text"/>
<input type="text"/>	<input type="text"/>
<input type="text"/>	<input type="text"/>

Internet Access This feature allows you to customize up to ten different Internet

Policy	Access Policies for particular PCs, which are identified by their IP or MAC addresses. For each policy designated PCs, during the days and time periods specified, only PCs listed on the list will be enabled/disabled at the policy.
Blocked Services	You may choose to block access to certain services. Click Add/Edit Services to modify these settings.
Website Blocking by URL	You can block access to certain websites by entering their URL.
Website Blocking by Keyword	You can block access to certain websites by the keywords contained in their web pages.

This feature allows you to restrict user access to specific web sites. To block a site, you can enter either a complete URL (Internet address) or keywords included in the URL.

3.9.2 Firewall

The settings page allows you to configure Firewall functions, providing superior security for your network environment.

Firewall Protection: Enable Disable

Additional Filters Filter Proxy Filter Cookies

Filter Java Applets Filter ActiveX

Block WAN Requests Block Anonymous Internet Requests

Firewall Protection: Enabling this function will prevent DoS (Denial of Service) attacks and activates the SPI (Stateful Packet Inspection). The SPI function will check any incoming data packets, particularly whenever there is a TCP connection initiated by your LAN PCs.

Web Filter: This feature provides options allowing you to filter any potential risk contained in some web technologies by individually checking "Allow" or "Deny".

Web proxy is a server your device will connect to when you access any web site. Setting web proxy can speed up access time but also can create other potential security issues. For example, if you configure the Wireless Security Router to block access to 216.115.102.76, which is the IP address of www.yahoo.com, it will fail. This is because your PC will connect to web proxy server instead of connecting to Yahoo's IP address.

Java & Active X are programming languages for web page. However, some potentially harmful Trojan programs and viruses are also written in these languages. If you deny access to either of these, you may run the risk of not having access to certain web pages.

A cookie is a small piece of data (usually in the form of a text file), which is stored on your PC when you visit certain web sites. This allows the server to identify your machine at a future date. The cookie normally contains an ID number but can also contain other information.

Block WAN Request: By enabling the Block WAN Request feature, you can prevent your network from being "pinged," or detected, by other Internet users. The Block WAN Request feature also reinforces your network security by hiding your network ports. Both functions of the Block WAN Request feature make it more difficult for outside users to work their way into your network. This feature is enabled by default. Check this to enable this feature.

3.10 Services

3.10.1 Virtual Server

The Virtual Server Settings application allows you to set up more than ten public services that can be accessed by external users of the Internet, such as a Web, Email, FTP etc. Each service is provided by a dedicated network computer (server) configured with a fixed IP Address. Although the internal service addresses are not directly accessible to the external user, the Wireless Security Router is able to identify the service requested by the service port number and redirects the request to the appropriate internal IP Address/server. To use this application, it is recommended you use a fixed Public IP Address from your ISP. Note that your Wireless Security Router supports only one server for each particular type.

Application	External Port	Internal Port	Protocol	IP Address	Enable
CVS	2401	2401	TCP	192.168.1.0	<input type="checkbox"/>
RemoteDesk	3389	3389	TCP	192.168.1.100	<input checked="" type="checkbox"/>
SNMP	161	161	UDP	192.168.1.0	<input type="checkbox"/>
NNTP	119	119	TCP	192.168.1.0	<input type="checkbox"/>
POP3	110	110	TCP	192.168.1.0	<input type="checkbox"/>
NTP	123	123	UDP	192.168.1.0	<input type="checkbox"/>
finger	79	79	TCP	192.168.1.0	<input type="checkbox"/>
TFTP	69	69	UDP	192.168.1.0	<input type="checkbox"/>
SMTP	25	25	TCP	192.168.1.0	<input type="checkbox"/>
Telnet	23	23	TCP	192.168.1.254	<input checked="" type="checkbox"/>
FTP	21	21	TCP	192.168.1.0	<input type="checkbox"/>

Set up individual network computers to act as servers and configure each with a fixed IP Address.

Application: Enter the name of application you wish to configure in the column to identify this setting.

Ext. Port Most of the applications usually use their individual port number for its incoming and outgoing data packets. However, some of the applications may use different port number for incoming and outgoing data packets. In this case, you have to enter the port number used by incoming data packets here.

Int. Ports Most of the applications usually use their individual port number for its incoming and outgoing data packets. However, some of the applications may use different port number for incoming and outgoing data packets. In this case, you have to enter the port number used by outgoing data packets here.

Protocol You can specify the protocol type as "TCP" or "UDP" from the drop-down list. If you are not sure which one to select, choose "Both". A selection of well-known service port numbers is provided on this screen.

IP Address Enter the appropriate IP Addresses of the service computers in the "IP Address" locations.

Example: If the service port number **80~80** (representing an HTTP web server) is entered in "**External Port**" and "**Internal Port**" while **192.168.1.100** is entered in "**IP Address**", then all HTTP requests from external Internet users will be directed to the

PC/server with the 192.168.1.100 fixed IP Address.

Below is a list of the protocols and port ranges that are used by some common applications.

Application	Protocol	Port Range
FTP Server	TCP	21
Half Life	UDP	6003, 7002, 27010, 27015, 27025
MSN Messenger	TCP	6891-6900 (File-send) 1863 1863 5190
	TCP	6901 (Voice)
	UDP	6901 (Voice)
PC Anywhere host	TCP	5631
	UDP	5632
Quake 2	UDP	27910
Quake III	UDP	27660 (first player) "C:\Program Files\Quake III Arena\quake3.exe" +set net_port 27660 27661 (second player)
Telnet Server	TCP	23
Web Server	TCP	80

3.10.2 Forwarding

This router also supports Port Forwarding. Some applications use consecutive TCP/UDP ports to transmit data. Please note that do not configure the server of the same function with different IP Addresses even through different configuration pages.

Forwarding Setting

Application	Start Port	End Port	Protocol	IP Address	Enable
BitTorrent	6881	6889	TCP	192.168.1.100	<input checked="" type="checkbox"/>
	0	0	Both	192.168.1.0	<input type="checkbox"/>
	0	0	Both	192.168.1.0	<input type="checkbox"/>

Application Enter the name of application you wish to configure in the Name column to identify this setting.

Start Port Enter the start port number used by incoming data packets here.

End Ports Enter the end port number used by incoming data packets here.

IP Address Enter the appropriate IP Addresses of the service computers in the "IP Address" locations.

Enable Check to make this trigger setting active.

For detailed port information of your desired applications, please refer to the internet resources.

3.10.3 Trigger

Some applications use multiple TCP/UDP ports to transmit data. Due to the NAT, these applications cannot work with the Wireless Security Router. Port Triggering allows some of these applications to work properly. Note that only one PC can use each Port Triggering setting at any time.

Port Trigger Setting

Application	Triggered Range		Forwarded Range		Enable
	Start Port	End Port	Start port	End Port	
DialPad	7175	7175	51200	51201	<input type="checkbox"/>
DialPad	7175	7175	51210	51210	<input type="checkbox"/>

Application Enter the name of application you wish to configure in the Name column to identify this setting.

Triggered Port Range Enter the port number or range numbers the application uses when it sends packets outbound. The Triggered Port acts as the trigger. When the Wireless Security Router detects the outgoing packets with these port numbers, it will allow the inbound packets with the Forwarded Port Numbers that you set in the next column to pass through the Wireless Security Router.

Forwarded Port Range: Enter the port number or range numbers the inbound packets carry.

Enable Check to make this trigger setting active.

The following is a list of port numbers used on some popular applications:

Application	Outgoing Control	Incoming Data
Battle.net	6112	6112
DialPad	7175	51200, 51201, 51210
ICU II	2019	2000-2038, 2050-2051 2069, 2085, 3010-3030
MSN Gaming Zone	47624	2300-2400, 28800-29000
PC to Phone	12053	12120, 12122, 24150-24220
Quick Time4	554	6970-6999

wowcall	8000	4000-4020
---------	------	-----------

Example: In the Battle.net application, only if the triggering port is configured to 6112 can the incoming packet with the destination port 6112 be forwarded to the desired PC, no matter the protocol is TCP or UDP.

3.10.4 DMZ Host

The DMZ Host application allows unrestricted 2-way communication between a single LAN PC and other Internet users or servers. This application is useful for supporting special-purpose services such as video-conferencing and gaming that require proprietary client software and/or 2-way user communication.

To use this application, you must first obtain a fixed Public IP Address from your ISP. Note that in order to provide unrestricted access, the Firewall provided by the Wireless Security Router to protect this port is disabled, thus creating a potentially serious security risk.

DMZ Hosting: Enable Disable

DMZ Host IP Address: 192.168.1. (valid range is 1-254)

It is recommended that this application is disabled when it is not in use by entering “0” in the “DMZ Host” field.

The Multi DMZ allows you to map the public IP addresses to your LAN PCs, should you get more than one public IP address from your ISP. This function is useful to set up your servers, such as an FTP server, web server, and so on, with public IP addresses, but still keep them within your LAN group.

With the public IP addresses, Internet users will access your servers more easily and those servers can still communicate with other PCs in you LAN by using Network Neighborhood.

Before setting up a LAN PC to act as a DMZ Host, you should configure it using a fixed IP Address.

4 Management

This chapter provides information on using Macintosh computers in your network. The instructions given here are for system software version 8.0 or above, which comes with the TCP/IP Protocol preloaded and supports DHCP Addressing.

4.1 Management Settings

This feature allows the administrator to manage the Wireless Security Router by setting certain parameters. For security reasons, it is strongly recommended that you set Passwords so that only authorized persons are able to manage this Wireless Security Router. If the Password is left blank, all users on your network can access this router simply by entering the unit's IP Address into their web browser's location window.

Gateway Username:	<input type="text" value="admin"/>
Gateway Password:	<input type="password" value="....."/>
Re-enter to confirm:	<input type="password" value="....."/>
Remote Management:	<input type="radio"/> Enable <input checked="" type="radio"/> Disable
Management Port:	<input type="text" value="8080"/>
Device Name:	<input type="text" value="WDR814g"/>
SNMP	<input type="radio"/> Enable <input checked="" type="radio"/> Disable
Get Community:	<input type="text" value="public"/>
Set Community:	<input type="text" value="private"/>
UPnP	<input checked="" type="radio"/> Enable <input type="radio"/> Disable

User Name: Enter the username you want. Be sure that the

	username is less than 64 characters long and without any special characters or spaces.
Password:	Enter the password you want to use into the “Password Change” field and re-enter it into the “Password Confirm” field for confirmation. Be sure that the password is less than 64 characters long and without any special characters or spaces.
Remote Management:	Check “Enable” to allow you to configure the Wireless Security Router from the WAN side. To access the setting page from the external side, enter “http://<WAN IP Address>:8080” into the web browser address bar and press the “Enter” key.
SNMP Function:	As with the Password, SNMP community allows authorized persons to access this router through the SNMP Management tool. The Wireless Security Router provides three fields to enter these communities. The default words Public and Private are well-known communities that allow authorized persons who know the IP Address of this router to access the read-only information about this router or have the authority to change the configuration. Also, the administrator can define any specific community and configure its limits as Read-Only or Read-Write from the right side drop-down box.
UPnP	UPnP (Universal Plug and Play) is a standard introduced from Microsoft and UPnP Forum for interoperability. Currently, this function supported by this device allows you to set virtual server from Windows OS that supports UPnP, such as Windows XP. Check “Enable” to allow the UPnP enabled.

4.2 Log

The Log application provides the administrator with the ability to trace Internet connection. With viewing the Log information, an administrator can send the record to a specific LAN PC to have the real time monitor.

Log	<input type="radio"/> Enable <input checked="" type="radio"/> Disable	<input type="button" value="View Logs"/>
Logviewer IP Address:	192.168.1.	<input type="text" value="255"/>
Email Alerts:	<input type="radio"/> Enable <input checked="" type="radio"/> Disable	
Denial of Service Thresholds:	<input type="text" value="20"/>	events (20 - 100)
SMTP Mail Server:	<input type="text"/>	
Email Address for Alert Logs:	<input type="text"/>	
Return Email Address:	<input type="text"/>	

Log:	Check the "Enable" option if you want to activate this function.
Send Log To:	Enter the IP address of the PC that you wish to use to view the Log information.
View Log:	Click this button to view the log on-line.
Send Log via E-mail:	The Firewall log can be sent via e-mail.
Denial of Service Thresholds:	The threshold is used to determine whether the attempt of establishing connection is DoS attack or not.
SMTP Mail Server:	The domain name of IP Address of your ISP's outgoing e-mail server. You may find this information when you apply for e-mail service from your ISP.
E-mail Alert to:	Enter the e-mail address you wish to send to.
Return Address:	Enter the e-mail address you wish to send to if the alert e-mail cannot be sent to the address above.

4.3 Diagnostic-Ping

This function allows you to test the connection between a router and LAN or between a router and the Internet.

Ping Test Target IP: . . .

Ping Size: Bytes

Number of Pings: (Range 1~100)

Ping Interval: Milliseconds

Ping Timeout: Milliseconds

Ping Result: **Pkt Sent:0 PktRecv:0 Avg Rtt:0**

Source IP:	You can chose to issue the ping test from the LAN side by selecting Router's private IP Address or from the WAN side by selecting Router's WAN IP Address.
Destination IP:	Enter the IP Address of the destination device you want to ping. If Router's LAN IP address is selected as Source IP, you only can ping LAN side device and vice versa.
Packet Number:	Enter the packet number you wish to use to ping the destination device. The maximum number is 50.
Packet Size:	Enter the number of packet size you wish to use to ping the destination device. The maximum packet size is 1514.
Time Between	Enter the time between two packets.
Time out:	Enter the time period waiting for response from destination device
Start:	Click this button to begin the ping test.
Ping Result:	The result will show the number of sending packets, number of packets received, and the average return time.

4.4 Upgrade Firmware

This setting page allows you to upgrade the firmware to the latest version to keep your router up-to-date. Before you upgrade the firmware, you have to get the latest firmware and save it on the PC you use to configure the router.

Firmware Upgrade :

Warning: Upgrading firmware may take a few minutes, please do **NOT** turn off the power or press the reset button.

Browse.. To select a file to upgrade, you have to enter path of the latest firmware you saved on the PC. You can choose “Browse” to view the folders and select the firmware.

Upgrade After you enter or select the path, click “Upgrade” to start the firmware upgrade process.

& Note:

Don't power off the router during the firmware upgrading, otherwise the incompleton of firmware upgrading will cause serious damage to the integrity of the router's firmware that will lead to router reboot failure.

5 Troubleshooting

This chapter provides solutions to problems you may encounter during installation and operation of your ADSL Wireless Router.

Hardware

Q: *The Power LED is off.*

Check that the power cable is properly connected to the ADSL Wireless Router, the power adapter and the socket.

Q: *The LAN Link LED is off.*

Check that the computer, hub or switch is properly connected to the ADSL Wireless Router.

Check that the computer's Ethernet card is properly installed.

Check that the ADSL Wireless Router and the computer are on the same network segment. If you are not sure, initiate the DHCP function (4-1) and set your computer to obtain an IP address automatically (3-3).

Check that the computer is using an IP address in the range of 192.168.1.2 ~ 192.168.1.254 and is therefore compatible with the ADSL Wireless Router's default IP address of 192.168.1.1 (3-3). Check also the Subnet Mask is set to 255.255.255.0

Q: *The DIAG LED stays lit.*

The DIAG LED should light up when the device is first powered up to indicate it is checking for proper operation. After a few seconds, the LED should go off. If it stays lit, the device is experiencing a problem. Please contact your dealer.

Q: *Why can't I configure the ADSL Wireless Router?*

First, check whether the ADSL Wireless Router is properly installed or not, including the LAN and WAN connections, and that all devices are switched on.

Next, check the IP configuration of your PC:

- n . For Windows 95/98 users: Run winipcfg.exe or winipcfg from *Run* on the *Start* menu. If there are no IP addresses shown, click Release All and then click Renew All to get the IP addresses.
- n . For Windows NT 4.0 users: run ipconfig.exe or ipconfig from *Run* on the *Start*

menu and follow the instruction as above.

Ensure that your PC and the ADSL Wireless Router are on the same network segment. If you are not sure, initiate the DHCP function and set you PC to obtain an IP address automatically.

Ensure that your PC is using an IP Address within the range 192.168.1.2 to 192.168.1.254 and thus compatible with the ADSL Wireless Router default IP address of 192.168.1.1

Finally, use the Ping command in MS-DOS mode to verify the network connection:

Ping 127.0.0.1 to check the TCP/IP stack of your computer

Ping gateway IP (Default: 192.168.1.1) to check the internal link of network.

Note if you're not able to view the web configuration screen for the ADSL Wireless Router, make sure that you remove any proxy setting within your Internet browser, or remove the dial-up settings within your browser.

Q: What can I do if I have forgotten the password for the ADSL Wireless Router?

You have to reset the Wireless Security Router back to the factory default setting by pushing the Reset button for longer than 5 seconds. Refer to the user's manual to re-configure the settings.

Q: I cannot access my ISP's home page, why?

Some ISPs, such as @Home, require that their host name be specifically configured into your computer before you can surf their local web pages. If you are unable to access your ISP's home page, enter your ISP's Domain Name into the OnePage Setup (3-3) to enable all computers in your LAN to have access to it. If you only want to allow specific computers to access these home pages, open the TCP/IP Properties window (2-4) on these computers, click the **"DNS Configuration"** tab and enter your ISP's Domain Name in the **"Domain Name Search Suffix"** location.

Client Side (Computers)

Q: I can't browse the Internet via the ADSL Wireless Router

Check the following:

- n . Check that the LAN Link/ACT LED on the front panel is lit to indicate proper connection between the computer and the ADSL Wireless Router.
- n . Check if both ends of the network cable are properly connected.
- n . Check that TCP/IP is installed on your computer (2-4).

For Windows 95/98, use an MS-Dos prompt to run "winipcfg" ("Ipconfig" for Windows NT). Check that the computer's IP Address is within the range of 192.168.1.2 ~ 192.168.1.254 and the Subnet Mask is 255.255.255.0. If you are using a fixed IP address, also check the Default Gateway IP Address and DNS address in **"More"**.

- n . Check that the values as stated above are the same in Status Monitor (4-7).

Q: I get a time out error when I enter a URL or IP address.

Check whether other computers work. If they do, ensure the computer's IP settings are correct (IP Address, Subnet Mask, Gateway IP Address and DNS) (3-3). Then check whether the ADSL Wireless Router's settings are correct (3-3).

A FAQ

Q: What is the maximum number of IP Addresses the ADSL Wireless Router can support?

The ADSL Wireless Router can support up to 253 IP Addresses in the range of 192.168.1.2~192.168.1.254.

Q: Where should the ADSL Wireless Router be installed on the network?

In a typical environment, the ADSL Wireless Router should be installed between the ADSL/Cable modem and your LAN. Connect the ADSL Wireless Router to the Ethernet port of the ADSL/Cable modem, and connect your PCs to the RJ45 jack on the LAN side.

Q: Does the ADSL Wireless Router support IPX or AppleTalk?

No. The ADSL Wireless Router was designed to provide a LAN with shared Internet access and supports only the TCP/IP Protocol. If your Novell or Apple system is configured with TCP/IP, the ADSL Wireless Router can support them.

Q: Does the ADSL Wireless Router support 100Mb Ethernet?

Yes, the ADSL Wireless Router supports both 10Mb & 100Mb Ethernet on the LAN side.

Q: What is "NAT" and what is it used for?

The Network Address Translation (NAT) Protocol translates multiple IP Addresses on a private LAN into a single public IP Address that is accessible to the Internet. NAT not only provides the basis for multiple IP Address sharing but also adds to the LAN's security since the multiple IP Addresses of LAN computers are never transmitted directly to the Internet.

Q: How can ADSL Wireless Router enable share of a single account by multiple users?

ADSL Wireless Router combines the following technologies to enable this function.

NAT (Network Address Translation): NAT is a technology which can create a private network domain behind a public IP. It is usually used as a firewall. It can also be used when there are not enough IP Addresses.

DHCP (Dynamic Host Configuration Protocol): DHCP is a protocol used to assign IP Address to internal computers automatically. It can save a lot of IP configuration. This protocol is supported by Windows 95/NT, Mac OS, and many other popular OS.

DNS (Domain name service): DNS is a protocol which translates a Domain Name to IP Addresses that Internet host can handle. Addressing systems using Domain name, like www.yahoo.com, is easier to use than an IP address, such as 204.71.177.70.

Q: What operating systems does ADSL Wireless Router series support?

ADSL Wireless Router uses standard TCP/IP protocol, it can work as long as you have the TCP/IP protocol installed in your operating system (For example: Windows 9x, Windows NT, Windows 2000, etc.)

Q: Can I use multiple E-mail accounts if I use ADSL Wireless Router?

Yes, you can. Some people think having one Internet account mean that they can only have one E-mail account. However, E-mail is set by mailbox accounts and is different from the account you use to connect to your ISP. If you want more E-mail accounts, you should contact your ISP or you can browse the Internet to apply for a free E-mail account.

Q: Can Internet users access LAN computers?

ADSL Wireless Router uses NAT to route all in/out packets. All external users can only see the IP of the ADSL Wireless Router and cannot access LAN computers. The LAN computers are well protected with the ADSL Wireless Router's natural firewall.

Q: When should I use DMZ host?

Enable DMZ host when you want to have unrestricted communication between your PC and the Internet, for example, playing Internet games (i.e. Ages of Empire) or having multimedia conferences (i.e. NetMeeting).

Q: Does the ADSL Wireless Router support PPTP of VPN packets pass through?

Yes. ADSL Wireless Router supports single session PPTP pass through.

Q: Does the ADSL Wireless Router series support IPsec?

Yes. ADSL Wireless Router supports single session IPsec pass through.

B Technical Specifications

Standards Compliance

ADSL G.dmt for 8Mbps downstream & 640Kbps upstream
ADSL G.lite for 1.5Mbps downstream & 512Kbps upstream
ADSL2 (G.992.3 and G.992.4) for full-rate ADSL and splitterless ADSL
ADSL2+(G.992.5) for 25Mbps downstream data rate
IEEE 802.3 10/100BASE-T/TX
IEEE 802.11g Wireless

Interface

One ADSL interface RJ-11 connector (WAN)
Four 10/100Mbps auto-sensing Ethernet RJ-45 ports with auto cross-over.
Wireless access point

Management

Web-based UI Management

LED Display

Power
Diag
Link for ADSL
Active for ADSL
Enable/Activity for Wireless interface
Enable/Activity for USB interface
Link/Activity for LAN port(s)

Environment

Operation Temperature: 0 ~ 40 degrees C (32 ~ 104 degrees F)
Storage Temperature: -20 ~ 60 degrees C (-4 ~ 140 degrees F)
Humidity: Operating 10 ~ 85% non-condensing
Storage 5% ~ 90% non-condensing

Dimension

193 (L) x 123 (W) x 32 (H) mm

Power

External, DC 12V, 1A

Mounting

Desktop / Wall-mounting

C Glossary

10Base-T / 100Base-T

The adaptation of the Ethernet standard for Local Area Networks (LANs). 10Base-T uses a twisted pair cable with maximum lengths of 100 meters and transmits data at 10Mbps maximum. 100Base-T is similar, but uses two pairs of high-quality twisted-pair wires and transmits at 100Mbps maximum.

Ad-hoc Network

Also known as the peer-to-peer network, an ad-hoc network allows all PCs participating in a wireless network and being within range, to communicate with each other. Users in the same ad-hoc network can share files, printers, and other network resources.

Adapter

A device that makes the connection to a network segment, such as Ethernet and modem cards and adapters.

ADSL

Asymmetric Digital Subscriber Line (ADSL), as its name indicates, is an asymmetrical data transmission technology with higher traffic rate downstream and lower traffic rate upstream. ADSL technology satisfies the bandwidth requirements of applications which demand “asymmetric” traffic, such as web surfing, file downloads and telecommuting.

Bandwidth

The amount of data that can be transmitted in a fixed amount of time.

Browser

A software application used to locate and display Web pages. Examples include Netscape Navigator and Microsoft Internet Explorer.

BSS

BSS is the acronym of Basic Service Set that consists of a wireless access point and a group of wireless client PCs.

Communication Protocols

Communication between devices requires they agree on the format in which the data is to be transmitted, sent and received. The communication protocols are a set of rules that define the data format.

Cookie

A Cookie is a piece of data stored on your PC that a web server can retrieve later to identify your machine. It is normally a text with ID number, but can include other information.

DHCP

DHCP, short for Dynamic Host Configuration Protocol, is a protocol for assigning dynamic IP Addresses to devices on a network. Dynamic Addressing means that a device can have a different IP Address each time it connects to the network.

Domain Name

A name that identifies one or more IP Addresses. For example, the domain name microsoft.com represents about a dozen IP Addresses. Domain names are used in URLs to identify particular Web pages. For example, in the URL <http://www.pcwebopedia.com/index.html>, the domain name is pcwebopedia.com.

DoS

DoS is the abbreviation for Denial of Service. This occurs when a computer or network is overwhelmed to the point that it can no longer function normally. For example, a hacker may use fake IP addresses to accumulate numerous connections to flood the server he wants to attack.

DDNS

DDNS is an acronym for Dynamic Domain Name Service. It helps map your dynamic(changing) IP address to the domain name of your host.

DNS

Short for Domain Name Server, DNS translates domain names into IP Addresses and help us recognize and remember domain names as they are alphabetic in form. The Internet actually runs on numbered IP Addresses. DNS servers translate domain names into their respective IP Addresses.

Ethernet

One of the most common Local Area Network (LAN) protocols. Ethernet uses a bus topology which supports a data transfer rate of 10 Mbps.

Firewall

A security system used to enforce an access control policy between an organization's networks and the Internet.

IEEE

Short for Institute of Electrical and Electronics Engineers, an organization best known for developing standards for the computer and electronics industry.

Internet

A global network connecting millions of computers for the exchange of data, news and opinions.

Intranet

A network based on the TCP/IP Protocol (an internet) belonging to an organization,

and accessible only by that organization's members, employees, or others with authorization.

Infrastructure Network

Unlike “ad-hoc” network, where users on a wireless LAN send data to each other directly, users on an “Infrastructure” network send data to another point through a dedicated access point. Additionally, the access point enables users on a wireless LAN to access an existing wired network to take advantage of sharing the wired networks resources, such as files, printers, and Internet access.

IP Address

An identifier for a computer or device on a TCP/IP network. Networks using the TCP/IP Protocol route messages based on the IP Address of the destination. The format of an IP address is a 32-bit numeric address written as four numbers separated by periods. Each number can be from zero to 255.

IPSec

Internet Protocol Security is a security standard for network transmission. It provides authentication and packet encryption over the Internet.

ISP

Short for Internet Service Provider, a company that provides access to the Internet, usually for a monthly fee. The ISP provides a software package, username, password and access phone number allowing users to log on to the Internet, browse the World Wide Web and send and receive e-mail.

Local Area Network (LAN)

A computer network that spans a relatively small area. Most LANs are confined to a single building or group of buildings. However, one LAN can be connected to other LANs over any distance via telephone lines and radio waves. A system of LANs connected in this way is called a wide area network (WAN)

MAC Address

Short for Media Access Control Address and in a hardware address that uniquely identifies each node of a network.

NAT

Short for Network Address Translation, a routing protocol that allows global IP Addresses to be translated into multiple private IP Addresses for use on internal LAN networks. The explosion in the use of the Internet has created a critical problem for the Internet Assigned Numbers Authority (IANA) which is in charge of assigning IP Addresses to Internet users, ISPs etc.. NAT is a technology that has been introduced to help maximize the utilization of assigned IAN and global IP Addresses.

Network Protocol

Network protocols encapsulate and forward data packets from one interface to another.

PAP/CHAP ISP

Short for Password Authentication Protocol and Challenge Handshake Authentication Protocol. Most ISPs use either one for user identification. If your ISP doesn't support

these two protocols, contact your ISP for an authentication script.

PPP

Short for Point-to-Point Protocol, a communications protocol for transmitting information over standard telephone lines between devices from different manufacturers.

PPPoE

Short for PPP over Ethernet, relying on two widely accepted standards, Ethernet and the Point-to-Point Protocol. It's a communications protocol for transmitting information between devices from different manufacturers over an Ethernet.

PPTP

Short for Point to Point Tunneling Protocol, PPTP encapsulates the packet for transmission over the Internet. It is similar to creating a private "tunnel" over a large public network and has almost equal security to a private network without actually leasing a private line.

Protocol

An agreed format for transmitting, sending and receiving data between two devices.

Roaming

The ability for a wireless device moving from one access point's range to another without losing the connection.

Router

An Internet device that routes requests for information to other routers until the information's location is found and the data can be transmitted back to the origin of the request.

SPI

SPI is an acronym for Stateful Packet Inspection. The SPI engine examines not just the headers of the packet, but also the packet contents, it can then determine more about the packet than just its source and destination information. Moreover, stateful inspection firewalls also close off ports until a connection to the specific port is requested.

TCP/IP

Short for Transmission Control Protocol and Internet Protocol, the suite of communications protocols that enable hosts on the Internet to connect and exchange streams of data.

VPN

VPN is an acronym for Virtual Private Network. Via access control and encryption, VPN brings the same security to data transmission through the Internet as if it is being transmitted through a private network. It not only takes advantage of economies of scale but also ensures high level security while the packet is sent over the large public network.

Wide Area Network (WAN)

A system of LANs being connected by telephone lines and radio waves. Although

some WANs may be privately owned, they are usually considered a means of public access.

WEP

An acronym for **Wired Equivalent Privacy**. It is an encryption mechanism used to protect your wireless data communications. WEP uses a combination of 64-bit/128-bit keys to encrypt data that is transmitted between all points in a wireless network to insure data security. It is described in the IEEE 802.11 standard.