



Operating Instructions and Parts Manual

Oscillating Edge Sander

Model: OES-80CS



WMH TOOL GROUP

2420 Vantage Drive
Elgin, Illinois 60124
Ph.: 800-274-6848
www.wmhtoolgroup.com

Part No. M-708447
Revision B1 1/07
Copyright © WMH Tool Group

Warranty and Service

WMH Tool Group, Inc., warrants every product it sells. If one of our tools needs service or repair, one of our Authorized Service Centers located throughout the United States can give you quick service. In most cases, any of these WMH Tool Group Authorized Service Centers can authorize warranty repair, assist you in obtaining parts, or perform routine maintenance and major repair on your JET® tools. For the name of an Authorized Service Center in your area call 1-800-274-6848.

MORE INFORMATION

WMH Tool Group is consistently adding new products to the line. For complete, up-to-date product information, check with your local WMH Tool Group distributor, or visit jettools.com.

WARRANTY

JET products carry a limited warranty which varies in duration based upon the product (MW = Metalworking, WW = Woodworking).

90 DAY WARRANTY	1 YEAR WARRANTY	2 YEAR WARRANTY	5 YEAR WARRANTY	LIFE LIFETIME WARRANTY
Lathe Accessories Machine Accessories Mobile Bases Safety Equipment Specialty Items Vise Accessories	Air Tools- Contractor Air Tools-Industrial Air Tools-Light Industrial Lubrication	Body Repair Kits Bottle Jacks Cable Pullers Cold Saws Hoists-Air Hoists-Electric Metalforming Mill/Drills Milling Machines	MW Bandsaws MW Drill Presses MW Finishing Equipment MW Lathes MW Precision Vises Pallet Trucks Rigging Equip. Service Jacks	Stackers Surface Grinders Tapping Trolleys-Air Trolleys-Electric Web Slings Winches-Electric
			Beam Clamps Chain Hoist-Manual Lever Hoists Pullers-JCH Models Scissor Lift Tables Screw Jacks Trolleys-Geared	Trolleys-Plain Winches-Manual WW Air Filtration WW Bandsaws WW Buffers WW Drill Presses WW Dust Collectors WW Dust Filters
			WW Dust Fittings WW Jointers WW Lathes WW Planers WW Sanders WW Shapers WW Tablesaws	Fastening Tools Mechanics Hand Tools Striking Tools Vises (non-precision) Clamps

WHAT IS COVERED?

This warranty covers any defects in workmanship or materials subject to the exceptions stated below. Cutting tools, abrasives and other consumables are excluded from warranty coverage.

WHO IS COVERED?

This warranty covers only the initial purchaser of the product.

WHAT IS THE PERIOD OF COVERAGE?

The general JET warranty lasts for the time period specified in the product literature of each product.

WHAT IS NOT COVERED?

Five Year Warranties do not cover woodworking (WW) products used for commercial, industrial or educational purposes. Woodworking products with Five Year Warranties that are used for commercial, industrial or education purposes revert to a One Year Warranty. This warranty does not cover defects due directly or indirectly to misuse, abuse, negligence or accidents, normal wear-and-tear, improper repair or alterations, or lack of maintenance.

HOW TO GET SERVICE

The product or part must be returned for examination, postage prepaid, to a location designated by us. For the name of the location nearest you, please call 1-800-274-6848.

You must provide proof of initial purchase date and an explanation of the complaint must accompany the merchandise. If our inspection discloses a defect, we will repair or replace the product, or refund the purchase price, at our option. We will return the repaired product or replacement at our expense unless it is determined by us that there is no defect, or that the defect resulted from causes not within the scope of our warranty in which case we will, at your direction, dispose of or return the product. In the event you choose to have the product returned, you will be responsible for the shipping and handling costs of the return.

HOW STATE LAW APPLIES

This warranty gives you specific legal rights; you may also have other rights which vary from state to state.

LIMITATIONS ON THIS WARRANTY

WMH TOOL GROUP LIMITS ALL IMPLIED WARRANTIES TO THE PERIOD OF THE LIMITED WARRANTY FOR EACH PRODUCT. EXCEPT AS STATED HEREIN, ANY IMPLIED WARRANTIES OR MERCHANTABILITY AND FITNESS ARE EXCLUDED. SOME STATES DO NOT ALLOW LIMITATIONS ON HOW LONG THE IMPLIED WARRANTY LASTS, SO THE ABOVE LIMITATION MAY NOT APPLY TO YOU.

WMH TOOL GROUP SHALL IN NO EVENT BE LIABLE FOR DEATH, INJURIES TO PERSONS OR PROPERTY, OR FOR INCIDENTAL, CONTINGENT, SPECIAL, OR CONSEQUENTIAL DAMAGES ARISING FROM THE USE OF OUR PRODUCTS. SOME STATES DO NOT ALLOW THE EXCLUSION OR LIMITATION OF INCIDENTAL OR CONSEQUENTIAL DAMAGES, SO THE ABOVE LIMITATION OR EXCLUSION MAY NOT APPLY TO YOU.

WMH Tool Group sells through distributors only. The specifications in WMH catalogs are given as general information and are not binding. Members of WMH Tool Group reserve the right to effect at any time, without prior notice, those alterations to parts, fittings, and accessory equipment which they may deem necessary for any reason whatsoever. JET® branded products are not sold in Canada by WMH Tool Group.

Table of Contents

Warranty and Service	2
Table of Contents	3
Warnings	4
Introduction	6
Specifications	6
Unpacking	7
Shipping Contents.....	7
Tools Needed for Assembly	7
Assembly	8
Stand Assembly	8
Installing Table and Motor Unit to Stand	8
Sanding Belt Installation.....	9
Drum Guard & Dust Port	10
Extension Table	10
Electrical	11
Grounding Instructions	11
115 Volt Operation	11
230 Volt Operation	11
Adjustments	12
Sanding Platen Angle Adjustment	12
Platen Lock Tension Adjustment	12
Changing the Sanding Belt.....	13
Belt Tracking Adjustment	13
Motor Mount Tracking Adjustment.....	14
Table Adjustment	14
Basic Operations	15
Horizontal Sanding.....	15
Vertical Sanding.....	15
Contour Sanding.....	16
Troubleshooting Operating Problems.....	17
Parts	17
Ordering Replacement Parts	17
Table and Motor – Parts.....	18
Sanding Belts.....	19
Table and Motor – Assembly.....	20
Idle Drum – Parts	21
Stand Assembly	23
Wiring Diagram.....	24

The specifications in this manual are given as general information and are not binding. WMH Tool Group reserves the right to effect, at any time and without prior notice, changes or alterations to parts, fittings, and accessory equipment deemed necessary for any reason whatsoever.

Warnings

1. Read and understand the entire owner's manual before attempting assembly or operation.
2. Read and understand the warnings posted on the machine and in this manual. Failure to comply with all of these warnings may cause serious injury.
3. Replace the warning labels if they become obscured or removed.
4. This Oscillating Edge Sander is designed and intended for use by properly trained and experienced personnel only. If you are not familiar with the proper and safe operation of an edge sander, do not use until proper training and knowledge have been obtained.
5. Do not use this machine for other than its intended use. If used for other purposes, WMH Tool Group disclaims any real or implied warranty and holds itself harmless from any injury that may result from that use.
6. Always wear approved safety glasses/face shields while using this Oscillating Edge Sander. Everyday eyeglasses only have impact resistant lenses; they are not safety glasses.
7. Before operating this edge sander, remove tie, rings, watches and other jewelry, and roll sleeves up past the elbows. Remove all loose clothing and confine long hair. Non-slip footwear or anti-skid floor strips are recommended. Do **not** wear gloves.
8. Wear ear protectors (plugs or muffs) during extended periods of operation.
9. Some dust created by power sanding, sawing, grinding, drilling and other construction activities contain chemicals known to cause cancer, birth defects or other reproductive harm. Some examples of these chemicals are:
 - Lead from lead based paint.
 - Crystalline silica from bricks, cement and other masonry products.
 - Arsenic and chromium from chemically treated lumber.Your risk of exposure varies, depending on how often you do this type of work. To reduce your exposure to these chemicals, work in a well-ventilated area and work with approved safety equipment, such as face or dust masks that are specifically designed to filter out microscopic particles.
10. Do not operate this machine while tired or under the influence of drugs, alcohol or any medication.
11. Make certain the switch is in the **OFF** position before connecting the machine to the power source.
12. Make certain the machine is properly grounded.
13. Make all machine adjustments or maintenance with the machine unplugged from the power source.
14. Form a habit of checking to see that all extra equipment such as adjusting keys, wrenches, scrap, stock, and cleaning rags are removed away from the machine before turning on.
15. Keep safety guards in place at all times when the machine is in use. If removed for maintenance purposes, use extreme caution and replace the guards immediately when maintenance is complete.
16. Make sure the edge sander is firmly secured to the floor before use.
17. Check damaged parts. Before further use of the machine, a guard or other part that is damaged should be carefully checked to determine that it will operate properly and perform its intended function. Check for alignment of moving parts, binding of moving parts, breakage of parts, mounting and any other conditions that may affect its operation. A guard or other part that is damaged should be properly repaired or replaced.
18. Provide for adequate space surrounding work area and non-glare, overhead lighting.
19. Keep the floor around the machine clean and free of scrap material, oil and grease.



Warnings

20. Keep visitors a safe distance from the work area. **Keep children away.**
21. Make your workshop child proof with padlocks, master switches or by removing starter keys.
22. Give your work undivided attention. Looking around, carrying on a conversation and “horse-play” are careless acts that can result in serious injury.
23. Maintain a balanced stance at all times so that you do not fall or lean against the sanding belt or other moving parts. Do not overreach or use excessive force to perform any machine operation.
24. Use the right tool at the correct speed and feed rate. Do not force a tool or attachment to do a job for which it was not designed. The right tool will do the job better and safer.
25. Use recommended accessories; improper accessories may be hazardous.
26. Maintain machinery with care. Follow instructions for lubricating and changing accessories.
27. Turn off the machine before cleaning. Use a brush or compressed air to remove dust or debris — do not use your hands.
28. Do not stand on the machine. Serious injury could occur if the machine tips over.
29. Never leave the machine running unattended. Turn the power off and do not leave the machine until it comes to a complete stop.
30. At all times hold the stock firmly.
31. Do not use this sander for other than it intended use. If used for other purposes, WMH Tool Group disclaims any real or implied warranty and holds itself harmless for any injury or damage which may result from that use.

Familiarize yourself with the following safety notices used in this manual:

CAUTION

This means that if precautions are not heeded, it may result in minor injury and/or possible machine damage.

WARNING

This means that if precautions are not heeded, it may result in serious injury or possibly even death.

Introduction

This manual is provided by WMH Tool Group covering the safe operation and maintenance procedures for a JET Model OES-80CS Sander. This manual contains instructions on installation, safety precautions, general operating procedures, maintenance instructions and parts breakdown. This machine has been designed and constructed to provide years of trouble free operation if used in accordance with instructions set forth in this manual. If there are any questions or comments, please contact either your local supplier or WMH Tool Group. WMH Tool Group can also be reached at our web site: www.wmhtoolgroup.com.

Specifications

Stock Number.....	708447
Fence	4"H x 24"L
Abrasive Belt Size	6"W x 89"L
Dust Chute Diameter	4"
Extension Table Size	9-7/8 x 11-7/8
Table Size	32"L x 7"W
Table Tilt	90°
Motor.....	1-1/2 HP, 1 Ph
.....	115/230V, prewired 115
Belt Speed (SPFM).....	3,900
Overall Dimensions	51"L x 26.5"W x 20"H
Net Weight (approx.).....	258 lbs.
Shipping Weight (approx.)	275 lbs.

The above specifications were current at the time this manual was published, but because of our policy of continuous improvement, WMH Tool Group reserves the right to change specifications at any time and without prior notice, without incurring obligations.

Unpacking

Upon delivery, open shipping containers and check that all parts are in good condition. Any damage should be reported to your distributor and shipping agent immediately. Before proceeding further, read your manual and familiarize yourself thoroughly with assembly, maintenance and safety procedures.

Compare the contents of your container with the following parts list to make sure all parts are intact. Missing parts, if any, should be reported to your distributor. Read the instruction manual thoroughly for assembly, maintenance and safety instructions.

Tools Needed for Assembly

- 2 12mm Wrench or sockets
- 1 10mm Wrench or sockets
- 1 Flat Head Screw Driver
- 1 Cross Point Screw Driver

Shipping Contents

- 1 Front Panel with Door (Stand)
- 1 Rear Panel (Stand)
- 2 Side Panel (Stand)
- 1 Shelf
- 2 M5x10 Screw
- 2 M5 Flat Washer
- 2 M5 Lock Washer
- 1 Extension Table Assembly
- 1 Drum Guard & Dust Port
- 1 Owner's Manual
- 1 Warranty Card
- 1 Table and Motor Unit
- 1 Back Stop Bracket
- 1 Belt Tension Handle
- 1 Belt Tracking Tool
- 1 Miter Gauge Assembly
- 1 Sanding Belt

Cabinet Hardware

- 1 Lock Knob (20mm Length)
- 2 Lock Knob (12mm Length)
- 1 Lock Knob (35mm Length)
- 4 Cabinet Pads
- 4 5/16" x 5/8" Screws
- 22 5/16" Flat Washers
- 12 5/16" Hex Nuts
- 8 5/16" x 5/8" Hex Cap Bolts
- 2 5/16" x 1-1/4" Hex Cap Bolts
- 4 Larger O/D 5/16" Flat Washers
- 10 5/16" Lock Washers

Extension Table Hardware

- 5 1/4" x 5/8" Hex Cap Bolts
- 5 1/4" Flat Washers
- 5 1/4" Lock Washers
- 1 Bracket
- 2 10-24x3/4 Socket Head Cap Screws

Dust Chute Hardware

- 3 Pan Head Screws

Assembly

Stand Assembly

Referring to Figure 1:

1. Remove all contents from the shipping container.
2. Clean all rust protected surfaces with a mild solvent. Do not use paint or lacquer thinner, gasoline, or mineral spirits; these will damage painted surfaces.
3. Attach the four *rubber pads* (A) to the bottoms of the *side panels* (C) with four each 5/16" x 5/8" screws, 5/16" flat washers and 5/16" hex nuts (B). The hardware can be found in the bag with the rubber pads.
4. Attach the *side panels* (C) to the *front panel* (D) with four 5/16" x 5/8" hex cap screws, eight 5/16" flat washers, four 5/16" lock washers, and four 5/16" hex nuts (E). Hand tighten the hardware at this point.

Note: Assemble the stand upside down to make sure that the tops of the panels are flush.

5. Mount the *shelf* (F) to the inside of the stand with two M5x10 pan head screws, two M5 flat washers and two M5 lock washers (G).
6. Finish the stand assembly by attaching the *rear panel* (H) to *side panels* (C) with four 5/16" x 5/8" hex cap screws, eight 5/16" flat washers, four 5/16" lock washers, and four 5/16" hex nuts (J).
7. Make sure stand is sitting evenly on a level surface before tightening hardware.

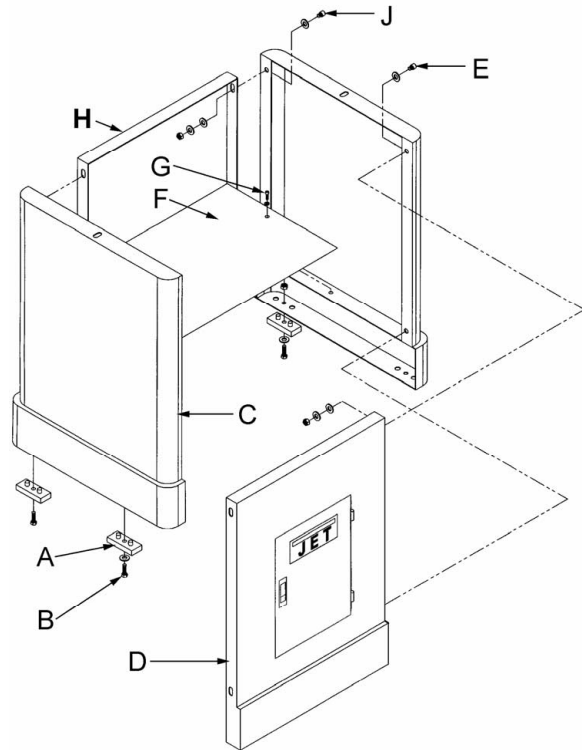

Figure 1

Installing Table and Motor Unit to Stand

⚠WARNING The Table and Motor Unit is heavy! Use great care and adequate resources when lifting the unit up onto the stand! Failure to comply may cause serious injury and/or damage to the sander and/or property!

Referring to Figure 2:

1. With the aid of another person, carefully lift the *table and motor unit* (A) out of the shipping box, and up onto the *stand* (B).
2. Line up threaded holes in the *base* (C) with the holes in the *stand* (D).
3. Open the *cabinet door* (E) and through the opening attach main unit to stand with two 5/16" x 1-1/4" hex cap screws (F), two 5/16" lock washers (G) and two 5/16" flat washers (H). Tighten with a 12mm wrench.

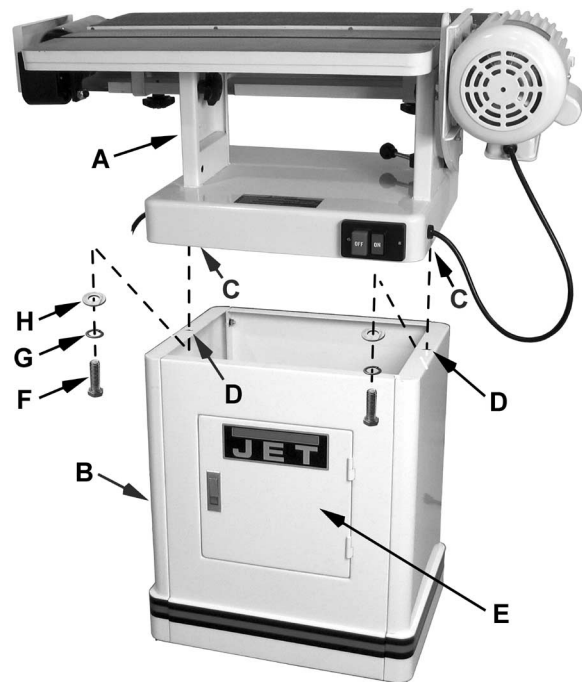

Figure 2

Referring to Figure 3:

4. The *sanding platen* (A) is presently in the horizontal position. Pull *lock handle* (B) forward to unlock the platen assembly.
5. Tilt sanding platen to the *vertical position* (C), which will look like D in Fig. 4; then push the *lock handle* (B) to lock the platen assembly in place.

Note: Do not *turn* the lock handle. *Turning* or *rotating* the lock handle will change the tension of the locking assembly. This may cause the locking assembly not to work, making it necessary for adjustment before using the machine.

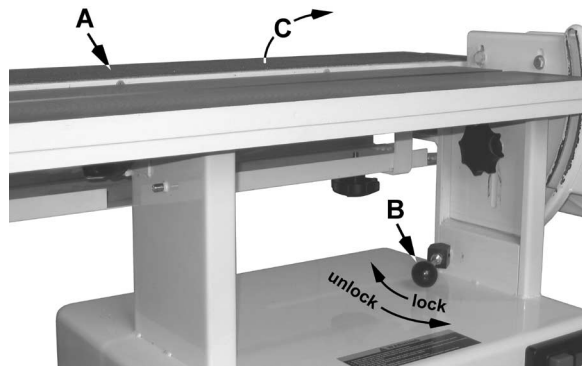

Figure 3



Figure 4

Sanding Belt Installation

Referring to Figure 5:

1. From the rear of the sander, remove the *belt guard* (A) by unscrewing two *lock knobs* (B). Take out the *sanding belt* and *removable fence* from behind the belt guard.
2. Place the *handle* (C) on *belt tensioning lever* (D). Remove the tension from the mechanism by moving the *handle* (C) to the *Loose* position.

3. Place belt on both rollers so that the edge of the belt is even with the edge of the rollers.

Note: Make sure that direction arrow on belt matches the direction indicator on the top of the platen.

4. Tighten the belt by moving the *tension arm handle* (C) to the *Tight* position. Rotate the belt by hand in the direction indicated by the arrow on top of the platen. If the belt tracking needs adjustment, see *Belt Tracking Adjustment* on page 13.

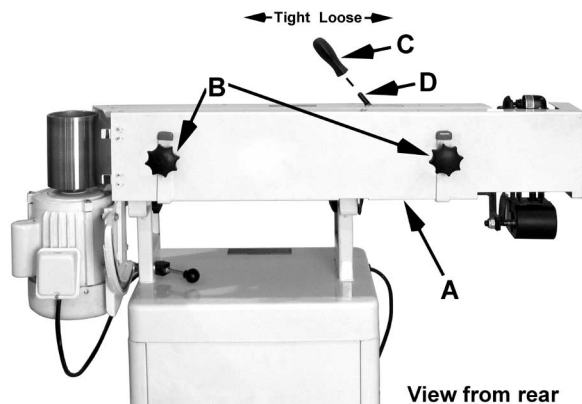

Figure 5

Drum Guard & Dust Port

Referring to Figure 6:

Mounting the Drum Guard & Dust Port (referred to below as *drum guard*)

1. Insert four M4x20 *flat head screws* (A) through the two *hinges* (B) of the *drum guard* (C). Then place two rectangular *spacers* (D) on the threaded ends of the screws.

Note: Orient the spacers so the slightly *rounded side* sits against the hinge and the edge *farther* from the screws lines up with the edge of the hinge.

2. Secure the *drum guard* (A) to the *belt guard* on the rear side of the sander by threading the screws through the *mounting holes* (E) in the belt guard. Tighten the screws.

Mounting the Connection Plate

3. Place the *drum guard* (C) in the closed position – this will cover the *drive drum* (J).

Note: You may have to slightly lift the cover when closing in order to clear the motor case. This is normal.

4. Place *washers* (G) on two small *lock knobs* (H) and then insert the threaded end of one lock knob through the slot of the *connection plate* (F) and the other lock knob through the hole of the *connection plate*.
5. Secure the slotted side of the extension plate to the *drum guard* (C) and the side with the hole to the *belt guard* (E).

When repositioning the drum guard, slightly loosen both lock knobs, open or close the cover, then secure the lock knobs.

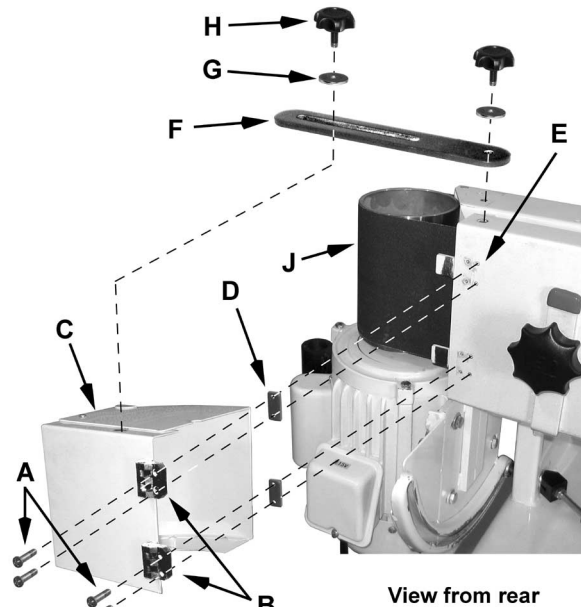

Figure 6

Extension Table

Referring to Figure 7:

1. Attach the *bracket* (E) for the extension table to the side of the *motor housing* (D) and secure with two *socket head cap screws* (F).
2. Slide the shaft of the *extension table* (C) into the *bracket* (E), positioning the table so the *opening* (B) wraps around the *drive drum* (A).
3. Insert *lock knob* (G) into the threaded hole on the side of the *bracket* (E) visible from the rear of the sander.

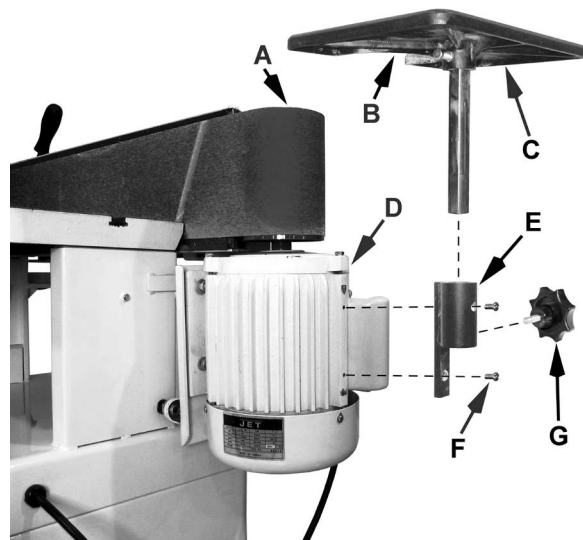

Figure 7

Electrical

Grounding Instructions

CAUTION This sander must be grounded while in use to protect the operator from electric shock.

In the event of a malfunction or breakdown, grounding provides a path of least resistance for electric current to reduce the risk of electric shock. This tool is equipped with an electric cord having an equipment-grounding conductor and a grounding plug. The plug must be plugged into a matching outlet that is properly installed and grounded in accordance with all local codes and ordinances.

Do not modify the plug provided. If it will not fit the outlet, have the proper outlet installed by a qualified electrician. Improper connection of the equipment-grounding conductor can result in a risk of electric shock. The conductor, with insulation having an outer surface that is green with or without yellow stripes, is the equipment-grounding conductor. If repair or replacement of the electric cord or plug is necessary, do not connect the equipment-grounding conductor to a live terminal.

Check with a qualified electrician or service personnel if the grounding instructions are not completely understood, or if in doubt as to whether the tool is properly grounded. Use only three wire extension cords that have three-prong grounding plugs and three-pole receptacles that accept the tool's plug.

Repair or replace a damaged or worn cord immediately.

115 Volt Operation

Referring to Figure 8:

As received from the factory, your Oscillating Edge Sander is ready to run at 115-volt operation. This Oscillating Edge Sander, when wired for 115 volt, is intended for use on a circuit that has an outlet and a plug that looks like the one illustrated in (A). A temporary adapter, which looks like the adapter shown in (B), may be used to connect this plug to a two-pole receptacle if a properly grounded outlet is not available.

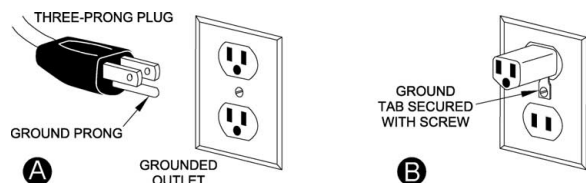

Figure 8

The temporary adapter should only be used until a properly grounded outlet can be installed by a qualified electrician. This adapter is not applicable in Canada. The green colored rigid ear, lug, or tab, extending from the adapter, must be connected to a permanent ground such as a properly grounded outlet box.

230 Volt Operation

Referring to Figure 9:

If 230V, single-phase operation is desired, the following instructions must be followed:

1. Disconnect the machine from the power source.
2. The JET Oscillating Edge Sander motor has four numbered leads that are factory connected for 115V operation, as shown in (A). For 230V operation reconnect the leads as shown in (B).
3. The 115V attachment plug (C) supplied with the Oscillating Edge Sander must be replaced with a UL/CSA listed plug suitable for 230V operation (D). Contact your local Authorized JET Service Center or qualified electrician for proper procedures to install the plug. The Oscillating Edge Sander must comply with all local and national codes after the 230-volt plug is installed.
4. The Oscillating Edge Sander with a 230-volt plug should only be connected to an outlet having the same configuration as shown in (D). No adapter is available nor should be used with the 230-volt plug.

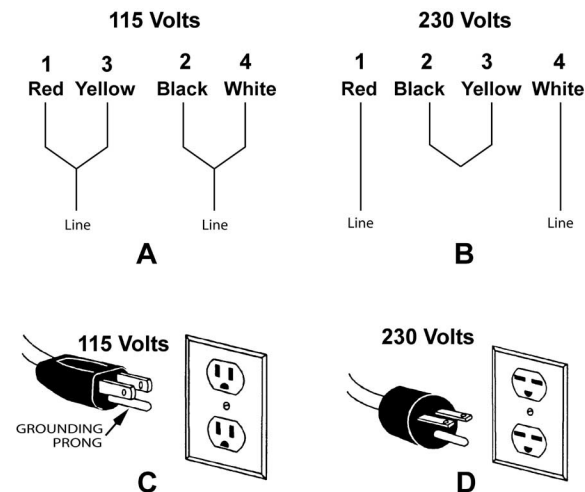

Figure 9

Extension Cords

Make sure your extension cord is in good condition. When using an extension cord, be sure to use one heavy enough to carry the current your machine will draw. An undersized cord will cause a drop in the line voltage resulting in power loss and overheating. Table 1 shows the correct size to use depending on the cord length and nameplate ampere rating. If in doubt, use the next heavier gauge. Remember, the smaller the gauge number, the heavier the cord.

Recommended Extension Cord Gauges

Amps	Extension Cord Length in Feet *					
	25	50	75	100	150	200
< 5	16	16	16	14	12	12
5 to 8	16	16	14	12	10	NR
8 to 12	14	14	12	10	NR	NR
12 to 15	12	12	10	10	NR	NR
15 to 20	10	10	10	NR	NR	NR
21 to 30	10	NR	NR	NR	NR	NR

*based on limiting the line voltage drop to 5V at 150% of the rated amperes.

NR: Not Recommended.

Table 1

Adjustments

Sanding Platen Angle Adjustment

Referring to Figure 10:

1. Disconnect the machine from the power source.
2. Pull the *lock handle* (B) forward (unlock) to release tension.

Move the *sanding platen* (A) to the desired position. Use a combination square between the table and sanding platen to get precise angles.

3. Hold the *platen* (A) while locking the handle.

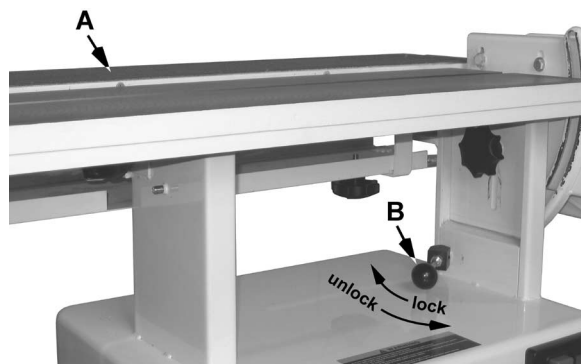

Figure 10

Platen Lock Tension Adjustment

1. Disconnect the machine from the power source.
2. Loosen (unlock) the *handle* (B, Fig. 10) and place the platen in the horizontal position as shown in (A, Fig. 10). Do not lock.
3. Tension eccentric block by tightening the nylon nut (B, Fig. 11) with a 14mm wrench. Turn the nut in by 1/4 turn increments and test locking handle for proper tension.

The *lock handle* is properly tensioned when it requires positive force to move the eccentric block (attached to the locking handle) from one side to the other. The platen and motor assembly must stay in a locked position without sliding once the handle has been moved to the locked position. Re-adjust as necessary.

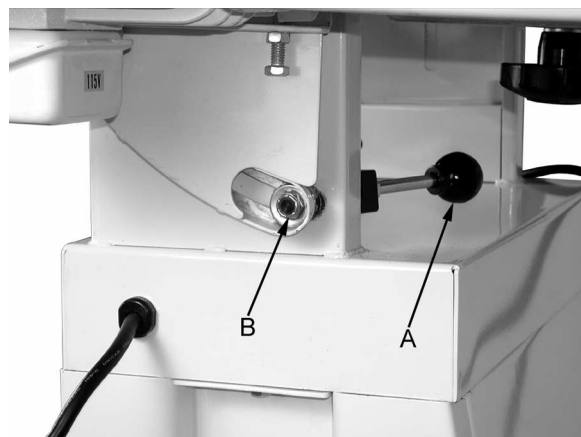

Figure 11

Changing the Sanding Belt

Referring to Figure 12:

1. Disconnect the machine from the power source.
2. Lock the sanding platen in the vertical position (see the *Sanding Platen Angle Adjustment* section on page 12).
3. Release tension on the belt by loosening the *handle (C)*.
4. Loosen or remove the *lock knobs (B)* and remove the *belt guard (A)*.
5. Remove the old belt and install the new belt matching the direction of the arrows on the belt with the arrow label on the top of the platen.
6. Line up edge of belt with edge of rollers.
7. Place tension on the belt by moving the *tension arm handle (C)* to the *Tight* position.
8. Reinstall the *belt guard (A)* and tighten the *lock handles (B)*

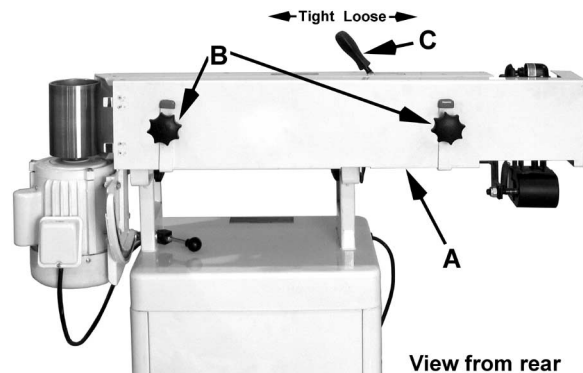

Figure 12

Note: Belts stretch with wear. When a belt is replaced, you may have to adjust tracking.

Belt Tracking Adjustment

The *Belt Tracking Adjustment* is a fine adjustment procedure. The *Motor Mount Tracking Adjustment* (following section) is a course adjustment.

To adjust the belt tracking:

1. Disconnect the machine from the power source.
2. Push the belt by hand from left to right (the direction indicated top of the platen) and observe the belt's position on the rollers. The oscillating movement of the belt is by design. Observe the belt's range of movement from its highest to lowest position. The edges of the belt should not have a tendency to move above or below the edges of the rollers.

If adjustment is still necessary:

3. Insert the round shaft of the *belt tracking tool* (provided) into the *micro adjust lock nut (A)* and turn away from you to loosen.
4. Turn the *micro adjusting screw (B)* in 1/4 turn increments until the belt tracks evenly on the rollers when rotated by hand.

Tip: Moving the belt tracking tool *away* from you *raises* the belt on the drum and *towards* you *lowers* the belt on the drum.

5. Tighten the micro adjusting nut (A).

Viewed from front

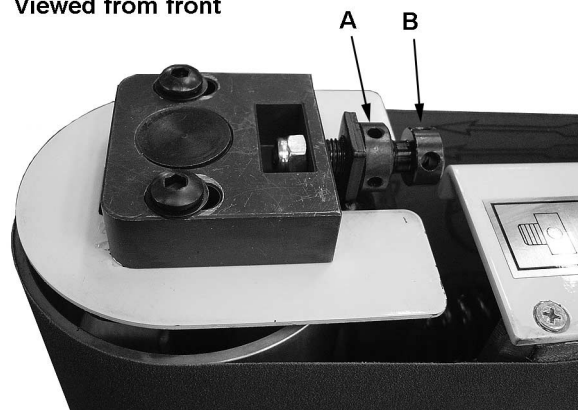

Figure 13

6. Connect the machine to power.
7. Turn on the power to the machine and observe the belt's up and down range of movement. Adjustment is correct when the edges of the belt do not move above or below the edges of the rollers.
8. When adjustment is complete, tighten the *micro adjust lock nut (A)*.

If the tracking cannot be corrected go to the *Motor Mount Tracking Adjustment* section (next page).

Motor Mount Tracking Adjustment

Referring to Figure 14:

The OES-80CS comes with tracking adjustment bolts (A) on the motor plate. These are set at the factory and should not require any further adjustment. If, however, you are not able to track the belt with the *Belt Tracking Adjustment* described in the previous section, the motor mount bolts will have to be adjusted.

Note: The *Motor Mount Tracking Adjustment* is a *course* adjustment. Use the *Belt Tracking Adjustment* first for *fine* adjustment. If it cannot be adjusted, *then* use the procedure described below.

To adjust:

1. Disconnect the machine from the power source.
2. Slightly loosen the four *motor mount nuts* (B) just enough so the *tracking screws* (A) can be turned to make an adjustment.
3. Loosen the two *locking hex nuts* (C) that secure the *tracking screws* (A).
4. Turn one *screw* (A) a 1/4 turn and rotate the sanding belt by hand to observe which direction the adjustment is causing the belt to move. If it is traveling in the direction needed to correctly track the belt go to step 6.
5. If the belt starts to travel in the wrong direction, back off a quarter turn and *tighten the other screw* a quarter turn. This should start the belt moving in the proper direction.
6. Tighten both *locking nuts* (C) and *motor mount nuts* (B). Then return to the Belt Tracking Adjustment section (previous page) and again attempt to fine tune the tracking.

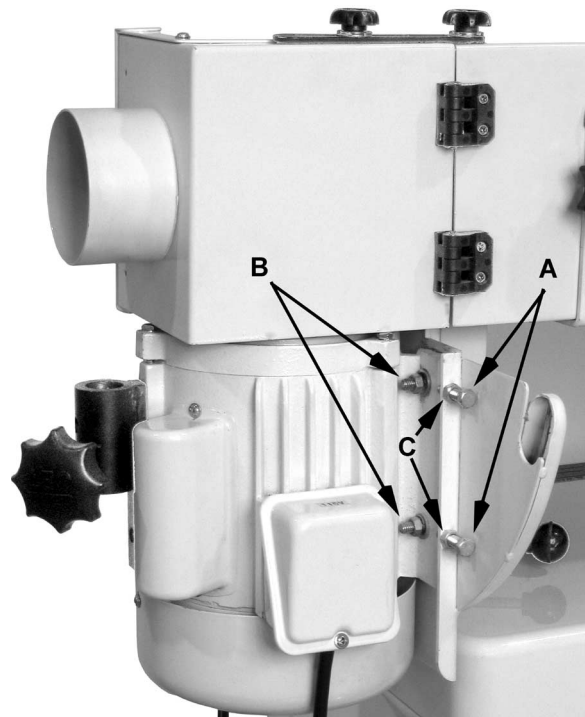

Figure 14

Table Adjustment

⚠WARNING Do not position table below sanding belt! Keep an overlap of at least 1/16" between table and sanding belt to avoid material and/or fingers getting caught! Failure to comply may cause serious injury!

1. Loosen two lock knobs (A, Fig. 15).
2. Raise or lower work table to desired level.
3. Tighten two lock knobs.

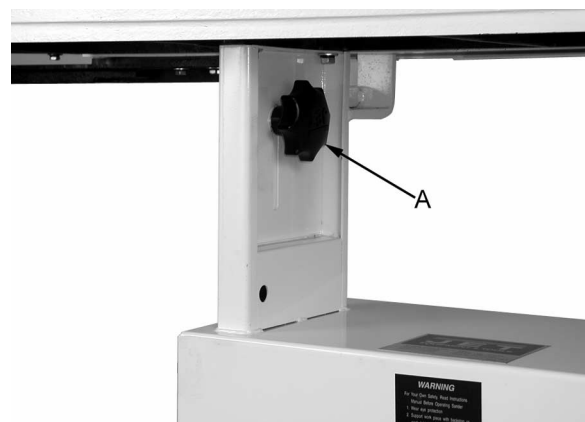

Figure 15

Basic Operations

⚠WARNING Removing the belt guard exposes more of the sanding belt! Replace the belt guards immediately after completing any sanding that requires its removal! Failure to comply may cause serious injury!

Horizontal Sanding

For *horizontal sanding*, the *platen* is locked in the horizontal position as shown (F) and the *removable fence* (D) is secured to the *table* (E) as follows.

Referring to Figure 16:

1. Place 5/16" *flat washers* (not shown) and *guide blocks* (B) on two 12mm *lock knobs* (A) – Note: the 12mm refers to the threaded shaft length.
2. Insert the *guide blocks* (B) into the *miter slot* (C) and position the *lock knobs* (G) on the *table* (E) as shown.
3. Place the *removable fence* (D) on the table and secure by tightening the *lock knobs* (G, Fig. 16 and Figure 17).

The *backstop* (H, Fig. 17) can also be used by swiveling the *drum guard & dust port* (J, Fig. 17) out of the way and placing the backstop pin in the positioning hole and securing in place with the *lock knob* (K, Fig. 17) and 5/16" *flat washer*. **Note:** This is better shown in Figure 18. The *drum guard & dust port* (J, Fig. 17) can then be returned to the position shown.

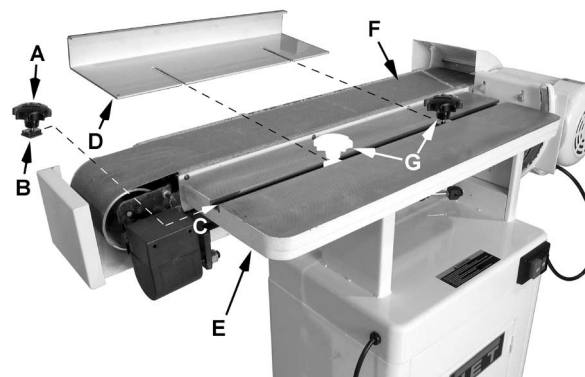

Figure 16

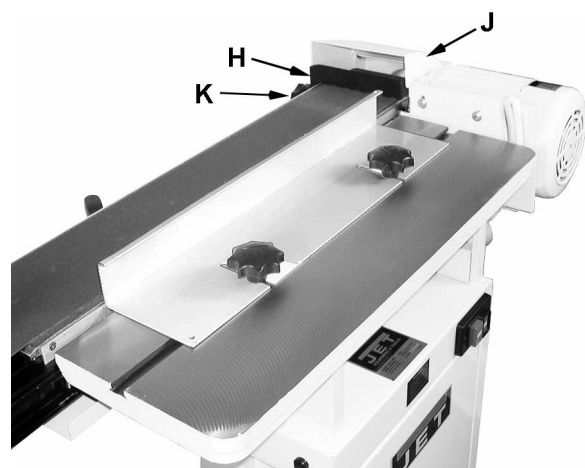

Figure 17

Vertical Sanding

Referring to Figure 18:

For *vertical sanding*, the *platen* (G) is locked in the vertical position as shown and the *backstop* (H) and/or the *miter gauge* (B) may be used.

Miter Gauge

1. Slide the *guide bar* (D) of the *miter gauge* (A) into the *miter slot* (C) on the table.
2. Set the miter angle; then secure the miter by tightening the *lock handle* (B).

Backstop

Place the backstop pin in the positioning hole and secure in place with the *lock knob* (E) and 5/16" *flat washer* (F).

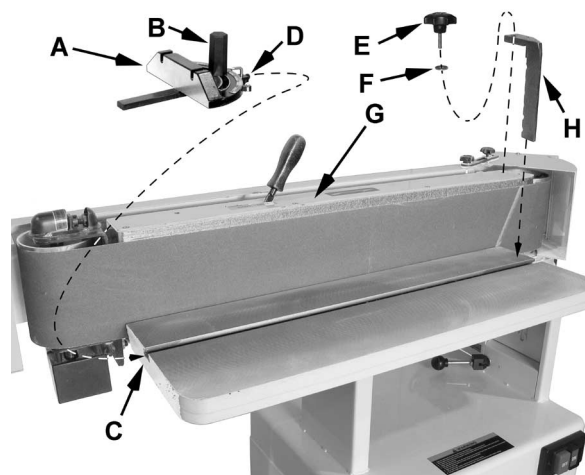

Figure 18

Contour Sanding

Referring to Figure 19:

Contour sanding is done from the extension table mounted on the motor where the sanding belt wraps around the *drive drum* (D). To set up the sander for contour sanding:

1. Loosen the two *lock knobs* (C) that secure the *drum guard & dust port* (E).
2. Swing the *end guard* (E) back, bringing the *drive drum* (D) into view.
3. Tighten the *lock knobs* (C).
4. Mount the *extension table* (A) to the sander by inserting the *post* (B) into the *bracket* (F).
5. Set the table to the desired height, then secure into position by tightening the *lock knob* (G).

Important: When the *extension table* (B) is not in use, the *drum guard & dust port* (E) should always be in the closed position so the *drive drum* (D) is not in view.

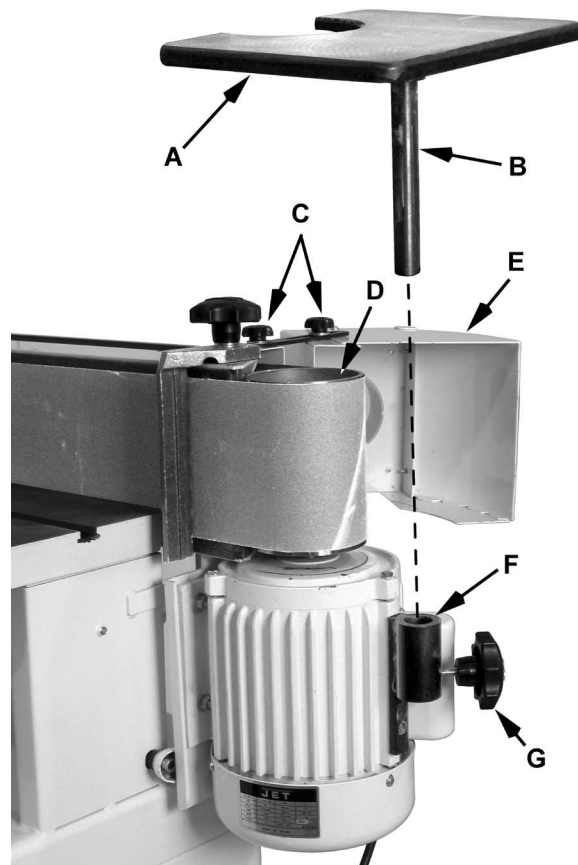

Figure 19

Troubleshooting Operating Problems

Trouble	Possible Cause	Solution
Sander will not start	<ol style="list-style-type: none"> 1. Sander unplugged from wall or motor 2. Fuse blown or circuit breaker tripped 3. Cord damaged 	<ol style="list-style-type: none"> 1. Check all plug connections 2. Replace fuse or reset circuit breaker 3. Replace cord
Sanding belt does not come up to speed	<ol style="list-style-type: none"> 1. Extension cord too light or too long 2. Motor not wired for proper voltage 3. Low current 	<ol style="list-style-type: none"> 1. Replace with adequate size and length cord (see <i>Recommended Extension Cord Gauges</i> on page 12) 2. Refer to motor junction cover for proper wiring 3. Contact a qualified electrician
Machine vibrates excessively	<ol style="list-style-type: none"> 1. Stand on uneven floor 2. Motor mounts are loose 3. Tension spring is worn or broken 	<ol style="list-style-type: none"> 1. Adjust stand so that it rests evenly on the floor 2. Tighten motor mount bolts 3. Replace spring
Abrasive belt keeps tearing	<ol style="list-style-type: none"> 1. Belt is running in the wrong direction 	<ol style="list-style-type: none"> 1. Arrow on the sanding belt and machine should be pointing in the same direction.
Sanded edge not square	<ol style="list-style-type: none"> 1. Table not square to sanding platen 	<ol style="list-style-type: none"> 1. Use a square to adjust table to sanding platen
Sanding marks on wood	<ol style="list-style-type: none"> 1. Wrong grit sanding belt 2. Feed pressure too great 3. Sanding against the grain 	<ol style="list-style-type: none"> 1. Use coarser grit for stock removal and fine grit for finish sanding. 2. Never force work into sanding platen 3. Sand with the grain

Parts

Ordering Replacement Parts

To order parts or reach our service department, call 1-800-274-6848 between 7:30 a.m. and 5:30 p.m. (CST), Monday through Friday. Having the Model Number and Serial Number of your machine available when you call will allow us to serve you quickly and accurately.

Table and Motor – Parts

Index No.	Part No.	Description	Size	Qty.
1	EHVS80CS-01	Base		1
2	EHVS80-02N	Push Button Switch		1
3	EHVS80-03N	Switch Panel		1
4	TS-081C082	Pan Head Screw	#10-24x1-1/2"	3
5	EHVS80-02B	Switch Box		1
6	TS-0560071	Hex Nut	#10-24	5
7	EHVS80-07	Strain Relief		2
8	EHVS80-08	Work Table Bar		1
9	TS-0640091	Nylon Insert Lock Nut	3/8"-16	1
10	EHVS80-10	Locking Block		1
11	EHVS80-11	Spring Pin	Ø4	1
12	EHVS80-12	Lock Handle		1
13	10102023A	Knob		1
	EHVS80-12A	Lock Handle Assembly (#12, #13)		1
14	S0430525	Key	5x5x25	1
15	TS-0050031	Hex Cap Screw	1/4"-20x3/4"	1
16	TS-0680021	Flat Washer	1/4"	5
17	EHVS80-17	Table		1
18	EHVS80-18	Screw	M10	2
19	TS-1540071	Hex Nut	M10	2
20	EHVS80-20	Guide Block		2
21	EHVS80-21	Fence		1
22	EHVS80-22A	JET Knob	M8x12mm	3
23	EHVS80-23	Drive Drum		1
24	EHVS80-24	Guide Bar		1
25	S0310306	Pin	Ø3	1
26	TS-0267021	Set Screw	1/4"-20x1/4"	1
27	EHVS80-27	Location Plate		1
28	EHVS80-28	Pointer		1
29	(See Below)	Sanding Belt	6"W x 89"L	1
30	10104046	Miter Gauge Body		1
	EHVS80-MG	Miter Gauge Assembly		
31	TS-081B042	Pan Head Screw	#8-32x5/8"	3
32	TS-0560061	Hex Nut	#8-32	3
33	EHVS80-33	Knob		1
34	20101048	Platen		1
35	OES80CS-135	Side Plate		1
	TS-0051061	Hex Cap Screw (motor plate – not shown)	5/16"-18x1-1/4"	2
	TS-0561021	Hex Nut (motor plate – not shown)	5/16"-18	2
36	EHVS80-36A	JET Knob	M8x35mm	1
37	EHVS80-37A	Pin	Ø6x40mm	1
38	TS-0561011	Hex Nut	1/4"-20	2
39	EHVS80-39A	Spacer		1
40	TS-0733031	External Tooth Lock Washer	#10	11
41	EHVS80-28A	Location Block		1
42	TS-0561031	Hex Nut	3/8"-16	1
43	TS-0051021	Hex Cap Screw	5/16"-18x5/8"	4
44	TS-0720091	Lock Washer	3/8"	2
45	EHVS80-49	Washer Head Screw	#10-24 x 3/8"	3
46	EHVS80-57	Tilt Scale		1
47	TS-081C052	Pan Head Screw	#10-24x3/4"	1
48	EHVS80-59	Pointer		1
49	TS-081C022	Pan Head Screw	#10-24x3/8"	2
50	OES80CS-150	Motor	1-1/2HP, 1Ph	1
51	TS-0051061	Hex Cap Screw	5/16"-18x1-1/4"	5
52	TS-0680031	Flat Washer	5/16"	10

Table and Motor – Parts

Index No.	Part No.	Description	Size	Qty.
53	OES80CS-153	Pin		2
54	EHVS80-67	Motor Cord		1
55	OES80CS-155	Dust Port		1
56	OES80CS-156	Sanding Belt Cover		1
57	EHVS80-70A	Up-Down Table Mount Plate		2
58	EHVS80-71A	JET Knob	M8X20mm	4
59	EHVS80-72	Back Stop Bracket		1
60	TS-0720081	Lock Washer	5/16"	14
61	TS-0561021	Hex Nut	5/16"-18	6
62	TS-0051061	Hex Cap Screw	5/16"-18x1-1/4"	2
63	TS-2285121	Flat Head Screw	M5x12	8
64	TS-2284201	Flat Head Screw	M4x20	8
65	EHVS80-94	Extension Table		1
66	EHVS80-96	Supporting Rod		1
67	EHVS80-57A	Tilt Angle Scale Label		1
68	EHVS80-108	Direction Label		1
69	EHVS80-107	Warning Label		1
70	EHVS80-68	Power Cord		1
71	OES80CS-171	Hinge		2
72	OES80CS-172	Knob	M6	2
73	OES80CS-173	Supporting Seat		1
74	TS-0206041	Socket Head Cap Screw	#10-24x3/4"	2
75	OES80CS-175	Spacer		2
76	EHVS80-34G	Graphite Pad		1
77	EHVS80-51	Belt Tension Arm		1
78	EHVS80-54	Tension Arm Handle		1
79	OES80CS-179	Connection Plate		1
80	EHVS80-111	Drum Guard		1
81	OES80CS-181	ID Label		1
82	OES80CS-182	Hinge Bracket		2

Sanding Belts

.....	57422810	040 Grit Open Coat
.....	57422910	060 Grit Open Coat
.....	57423010	080 Grit Open Coat
.....	7423110	100 Grit Open Coat
.....	57423210	120 Grit Open Coat
.....	57423310	150 Grit Open Coat
.....	57423410	180 Grit Open Coat
.....	57618210	040 Grit Closed Coat
.....	57618410	060 Grit Closed Coat
.....	57618510	080 Grit Closed Coat
.....	57618610	100 Grit Closed Coat
.....	57618710	120 Grit Closed Coat
.....	57512410	150 Grit Closed Coat
.....	57512510	180 Grit Closed Coat

Table and Motor – Assembly

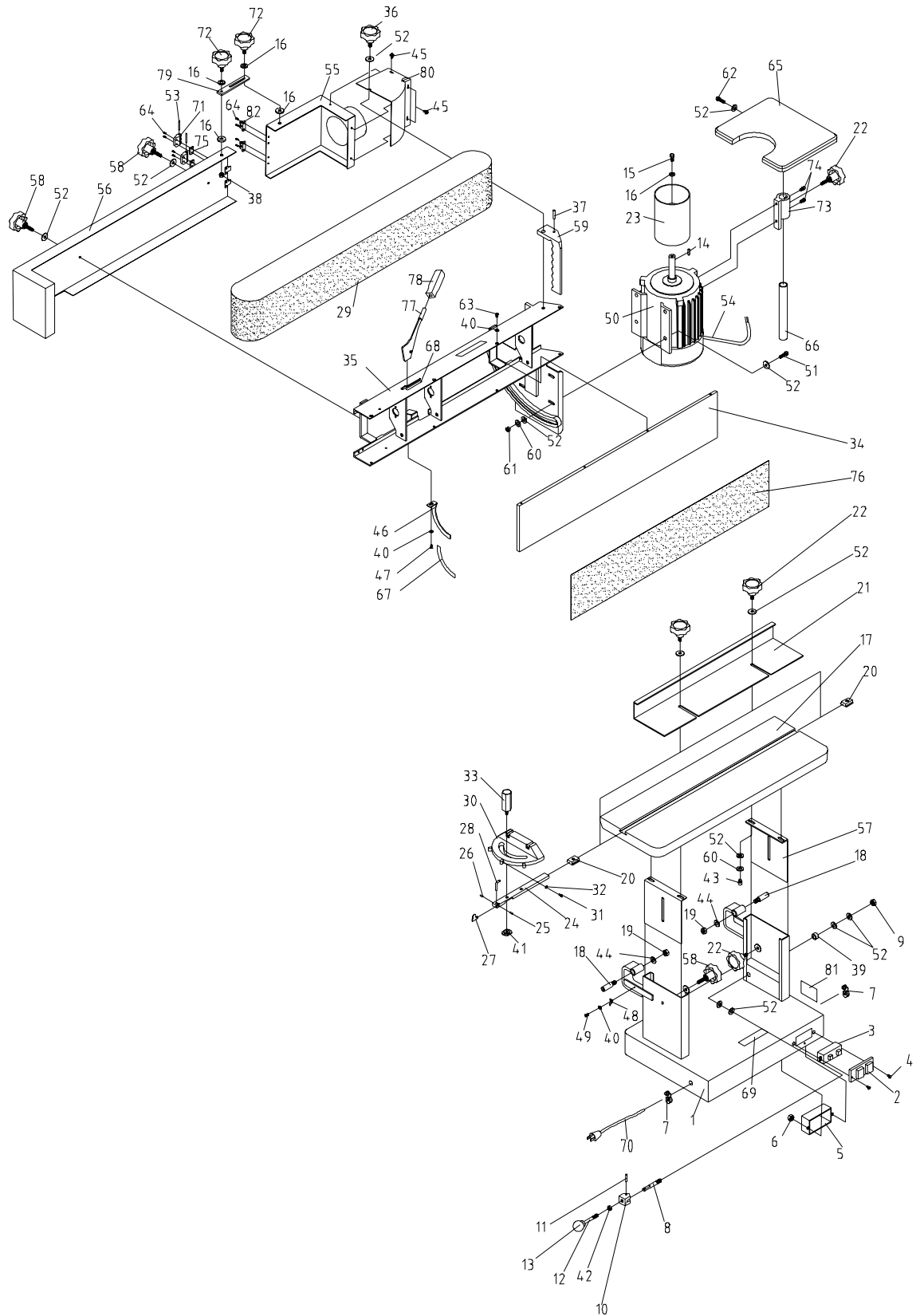

Idle Drum – Parts

Index No.	Part No.	Description	Size	Qty.
1	OES80CS-201	Tension Bar		1
2	OES80CS-203	Spring		1
3	TS-0561021	Hex Nut	5/16"	1
13	TS-1523011	Socket Set Screw	M6x6	2
15	S0400545	Key	5x5x45mm	1
16	OES80CS-216	Worm		1
17	OES80CS-217	Spacer		1
18	S0400425	Key	4x4x25	1
19	TS-0640081	Nylon Insert Lock Nut	5/16"	6
20	TS-0680031	Flat Washer	5/16"	4
22	TS-0720081	Lock Washer	5/16"	6
23	TS-2342141	Nylon Insert Lock Nut	M14	2
24	OES80CS-224	Bracket		1
25	TS-0050031	Hex Cap Screw	1/4"-20x3/4"	2
26	OES80CS-226N	Lead Screw		1
27	OES80CS-227	Spring		1
28	OES80CS-228	Ball Bearing	698	3
29	OES80CS-229	Retaining Ring	STW-8	1
30	TS-1502051	Socket Head Cap Screw	M5x20	2
31	TS-0208061	Socket Head Cap Screw	5/16"x1"	1
32	TS-2284121	Flat Head Screw	M4x12	3
34	BB-6202VV	Ball Bearing	6202LLU	2
35	OES80CS-235	Bearing Housing		1
36	BB6003ZZ	Ball Bearing	6003ZZ	1
37	S0400430	Key	4x4x30	1
38	OES80CS-238	Gear Housing		1
39	TS-1502021	Socket Head Cap Screw	M5x10	5
40	OES80CS-240	Bushing		2
41	OES80CS-241	Cam		1
42	OES80CS-242	Worm Gear		1
43	OES80CS-243	Worm Gear Shaft		1
44	OES80CS-244	Column		2
48	TS-0051081	Hex Cap Screw	5/16"-18x1-3/4"	1
49	TS-1551031	Lock Washer	M5	6
50	OES80CS-250	Rod		1
52	EHVS80-81	Belt Tracking Tool		1
53	TS-0810012	Round Head Slotted Machine Screw	#10-24x1/4"	4
54	OES80CS-254	Self Tapping Screw	M3x6	1
55	OES80CS-255	Dust Hood (Left)		1
56	OES80CS-256	Dust Hood (Right)		1
57	OES80CS-257	Ring		2
58	OES80CS-258	Wave Washer		2
59	OES80CS-259	Idle Drum		1
60	OES80CS-260	Track Adjusting Block		1
61	OES80CS-261	Drive Shaft		1
62	OES80CS-262	Button Head Socket Screw	5/16"X1-3/4	2
63	OES80CS-263	Guard		1
65	OES80CS-265	Foam Sheet for Drive Shaft		1
66	OES80CS-266	Idle Drum Bracket		1
67	OES80CS-267	Track Adjusting Screw		1
68	OES80CS-268	Track Adjusting Nut		1
69	OES80CS-269	Retaining Ring	S10	1
70	OES80CS-270	Bearing Housing		1
71	OES80CS-271	Foam Sheet for Lead Screw		1
72	OES80CS-272	Cone Disc Spring		2
	OES80CS-IDRA	Idle Drum Complete Assembly (index # 1-72)		

Idle Drum – Assembly

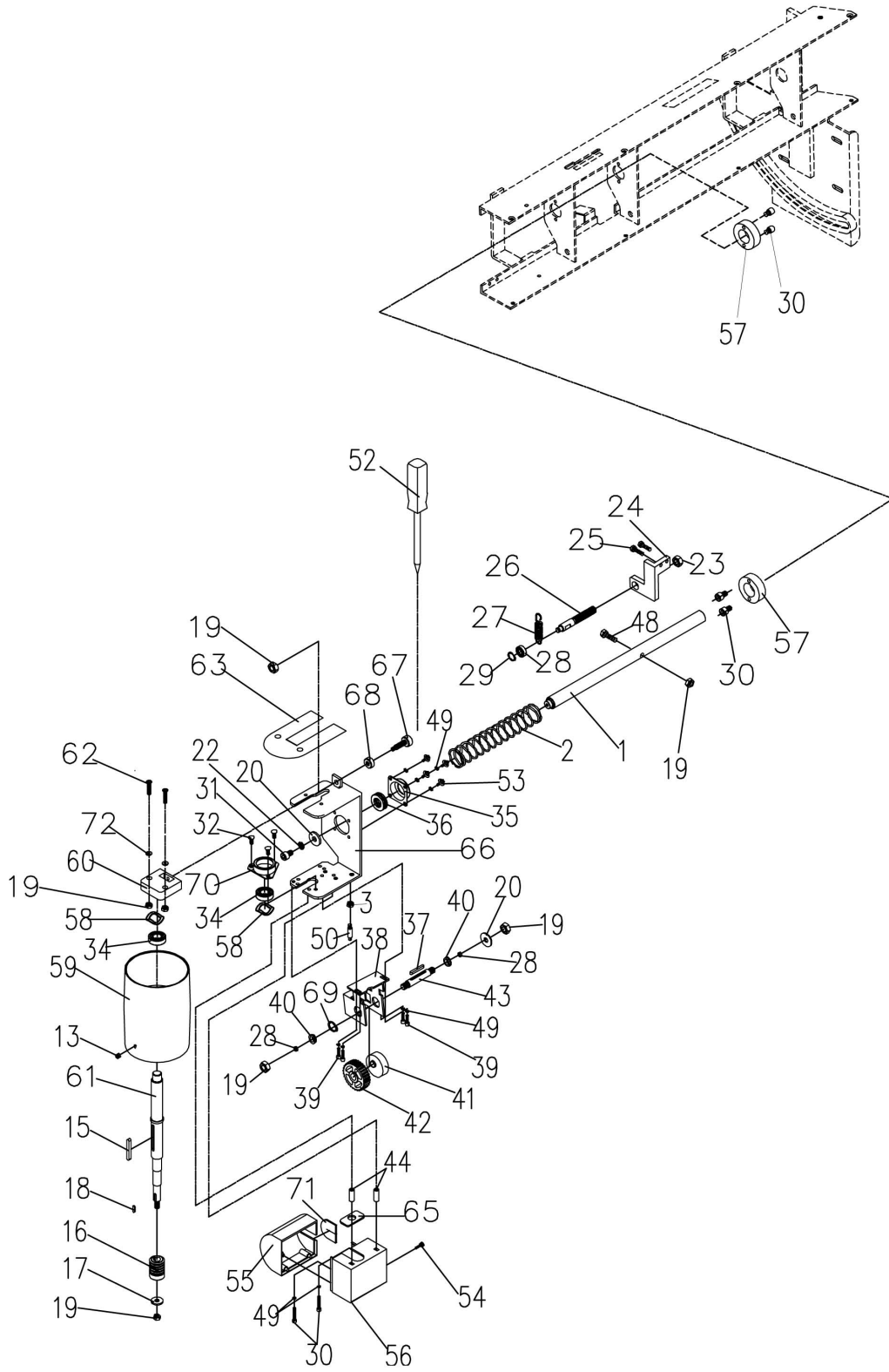

Stand Assembly

Index No.	Part No.	Description	Size	Qty.
1	TS-0680031	Flat Washer	5/16"	22
2	TS-0720081	Lock Washer	5/16"	10
3	TS-0561021	Hex Nut	5/16"-18	8
4	EHVS80CS-S04	Side Panel		2
5	EHVS80CS-S05	Pad		4
6	EHVS80CS-S06	Screw		4
7	EHVS80CS-S07	Rear Panel		1
8	TS-0561021	Hex Nut	5/16"-18	4
9	TS-0051061	Hex Cap Screw	5/16"-18x1-1/4"	2
10	TS-1533032	Pan Head Screw	M5x10	2
11	EHVS80CS-S11	Door		1
12	EHVS80CS-S12	Shelf		1
13	EHVS80CS-S13	Latch Assembly		1
14	TS-1551031	Lock Washer	M5	2
15	EHVS80CS-S15	Front Panel (W/Door)		1
16	EHVS80CS-S16	Screw		2
17	EHVS80CS-S17	JET Label		1
18	TS-1550031	Flat Washer	M5	2
19	TS-0081031	Hex Cap Screw	5/16"-18x3/4"	8

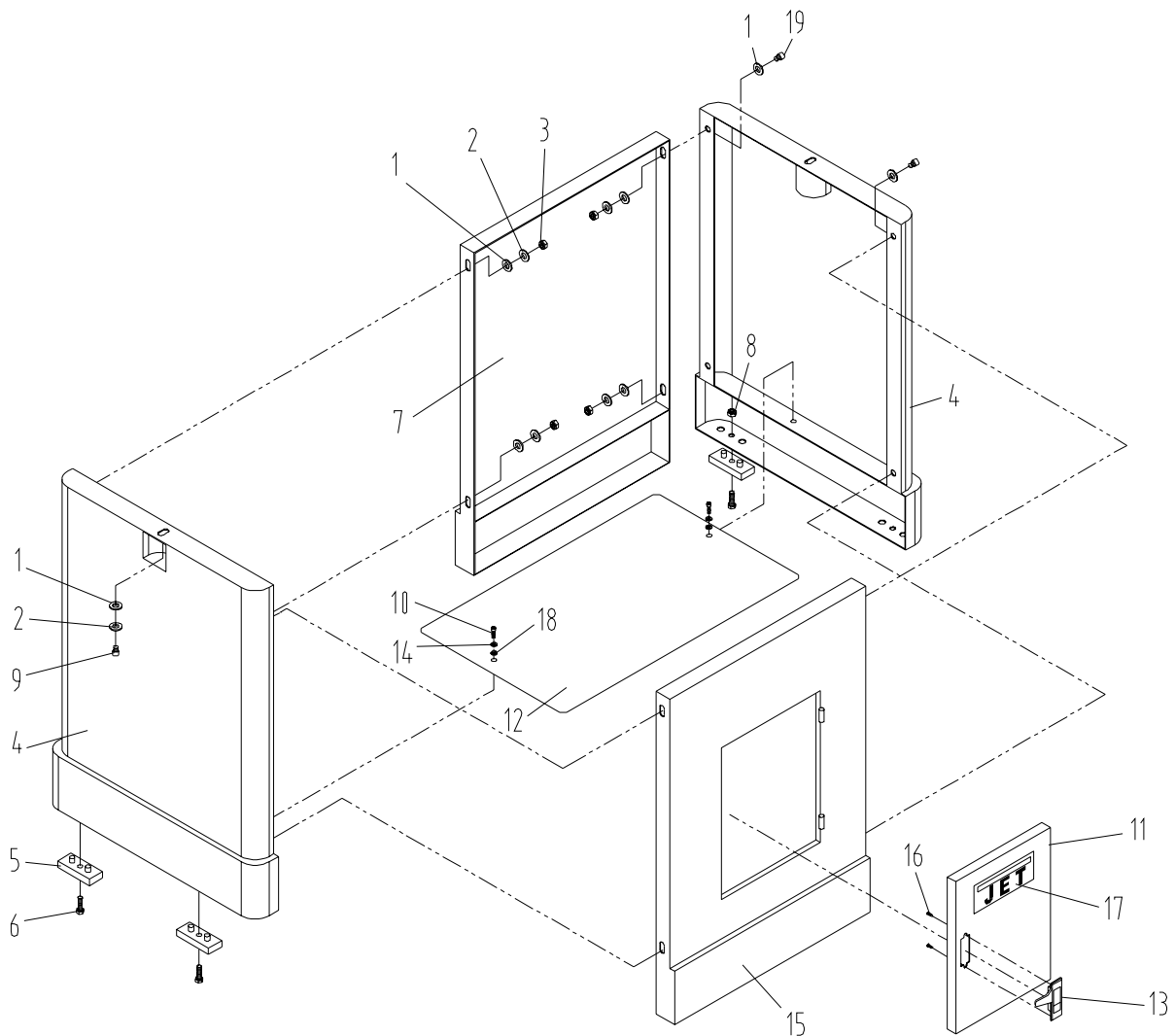

Wiring Diagram

EHVS-80CS ELECTRICAL SCHEMATIC-115V

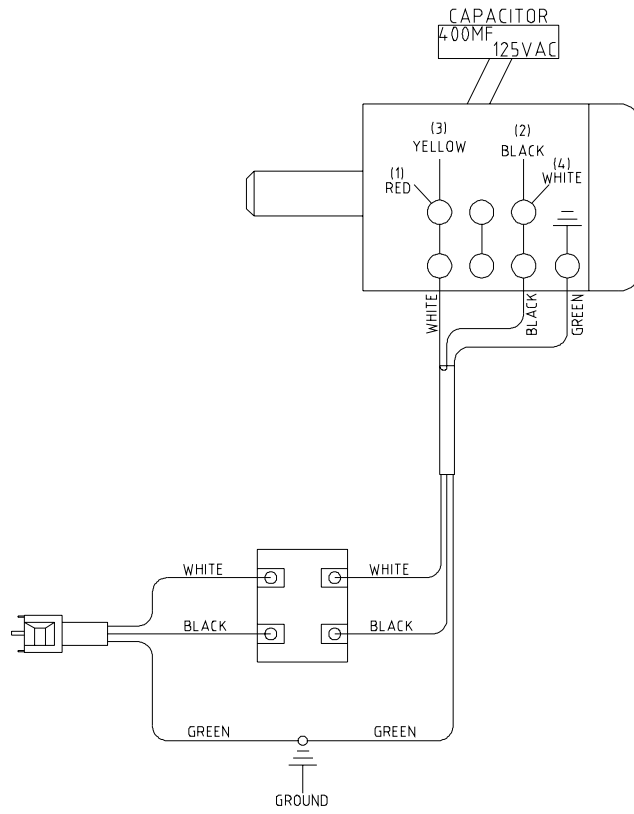

EHVS-80CS ELECTRICAL SCHEMATIC-230V

