



D2267

Dust Collection Nozzle

The Shop Fox® D2267 is designed to position the suction of your dust collector near machines that are not equipped with dust ports and near other sources of wood chips. The nozzle is attached to a fully adjustable stand that permits an endless combination of nozzle positions.

Tools Needed:

Phillips Screwdriver

! WARNING

Be sure to read the entire instruction sheet before beginning the construction of this product. Follow every step and use the recommended tools and supplies. Also, read the instruction manuals for any tools you are using to complete this project. Be certain that the tools used for this installation are intended for the task which will be performed. Failure to do this could result in serious personal injury.



! WARNING

Wear safety glasses during the entire assembly process. Failure to comply may result in serious personal injury.

NOTICE

The performance of your Model D2267 will only be as good as the performance of your dust collector. Regular maintenance of your dust collector will ensure maximum performance from your Model D2267, within the limitations of your dust collector.

Assembly:

1. Thread the (3) M8-1.25 x 25 Feet into the bottoms of the (3) Legs.
2. Using the (12) M6-1 x 8 Phillips Head Screws, 6mm Lock Washers, and 6mm Flat Washers, attach the (3) Legs to the Main Tube Body. Be sure the Lock Washers are between the Flat Washers and the Phillips Screw heads when tightened down.
3. Thread the M8-1.25 x 20 Lock Knob into the threaded hole on the side of the Main Tube Body.
4. Attach the Fixed Support to the top end of the Silver Main Tube Body using (2) M6-1.0 x 20 Phillips Head Screws.
5. Thread the M10-1.5 Hex Nut onto the end of the M10-1.5 x 15 Lock Knob. Place the end of the Lock Knob and Hex Bolt assembly through the slot on the Vacuum Tube. After the knob has been slide through the slot, place the 10mm Flat Washer on the threaded end of the Knob.
6. Carefully thread the Knob into the threaded hole in the Fixed Support. Be sure the Flat Washer is between the Fixed Support and the Vacuum Tube. This Washer acts as a pivot point when adjusting the Nozzle position. Tighten the Knob until the Vacuum Tube remains stationary.
7. Slide the Nozzle into the end of the Vacuum Tube. The Nozzle can be rotated 360° within the Vacuum Tube. Thread the M6-1 x 15 Lock Knob into the threaded hole on the top of the Vacuum Tube. This Knob locks the Nozzle into position.
8. You are now ready to enjoy dust collection in just about any location of your shop. If the Stand is unlevel, thread the Feet in and out until proper adjustment is achieved.

If You Need Assistance:

We hope you will find that your Shop Fox® Model D2267 is easily assembled and put to use. Should you have any questions about this product, please contact the dealer where you purchased it, or you can contact the Woodstock International Technical Department at 1-360-734-3482, Monday through Friday, between the hours of 7:00 am to 5:00 pm PST or e-mail us at: tech-support@woodstockint.com

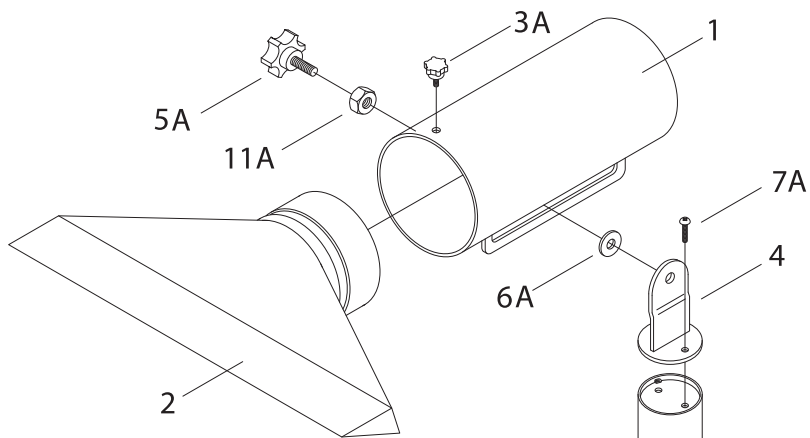

REF	PART #	DESCRIPTION
1	XD2267001	VACUUM TUBE
2	XD2267002	NOZZLE
3A	XD2267003A	LOCK KNOB M6-1 X 15
4	XD2267004	FIXED SUPPORT
5A	XD2267005A	LOCK KNOB M10-1.5 X 15
6A	XPW04M	FLAT WASHER 10MM
7A	XPS26M	PHLP HD SCR M6-1 X 20
8A	XD2267008A	MAIN TUBE BODY
9A	XD2267009A	LOCK KNOB M8-1.25 X 20
10	XD2267010	SILVER MAIN TUBE BODY
11A	XPN02M	HEX NUT M10-1.5
12A	XPS03M	PHLP HD SCR M6-1 X 8
13A	XD2267013A	LEG
14A	XPLW03M	LOCK WASHER 6MM
15A	XPW03M	FLAT WASHER 6MM
16A	XD2267016A	FOOT M8-1.25 X 25

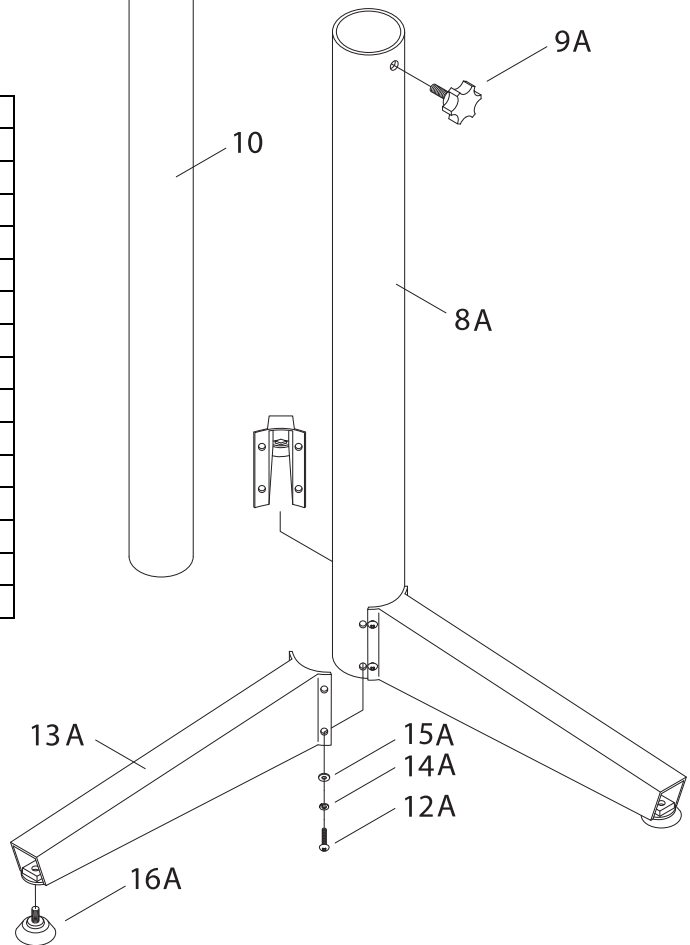

COPYRIGHT © APRIL 2002 BY WOODSTOCK INTERNATIONAL, INC. REVISED SEPTEMBER, 2010 (TR)

WARNING: NO PORTION OF THIS MANUAL MAY BE REPRODUCED IN ANY SHAPE OR FORM WITHOUT THE WRITTEN APPROVAL OF WOODSTOCK INTERNATIONAL, INC.

www.woodstockinternational.com

433402922