



MODEL W1671 Mortising Machine



INSTRUCTION MANUAL

Phone: 1-360-734-3482 • On-Line Technical Support: tech-support@woodstockint.com

COPYRIGHT © 2002 BY WOODSTOCK INTERNATIONAL, INC. REVISED JANUARY, 2012 (TR)

WARNING: NO PORTION OF THIS MANUAL MAY BE REPRODUCED IN ANY SHAPE OR FORM WITHOUT

THE WRITTEN APPROVAL OF WOODSTOCK INTERNATIONAL, INC.

Printed in China



WARNING!

This manual provides critical safety instructions on the proper setup, operation, maintenance and service of this machine/equipment.

Failure to read, understand and follow the instructions given in this manual may result in serious personal injury, including amputation, electrocution or death.

The owner of this machine/equipment is solely responsible for its safe use. This responsibility includes but is not limited to proper installation in a safe environment, personnel training and usage authorization, proper inspection and maintenance, manual availability and comprehension, application of safety devices, blade/cutter integrity, and the usage of personal protective equipment.

The manufacturer will not be held liable for injury or property damage from negligence, improper training, machine modifications or misuse.



WARNING!

Some dust created by power sanding, sawing, grinding, drilling, and other construction activities contains chemicals known to the State of California to cause cancer, birth defects or other reproductive harm. Some examples of these chemicals are:

- Lead from lead-based paints.
- Crystalline silica from bricks, cement and other masonry products.
- Arsenic and chromium from chemically-treated lumber.

Your risk from these exposures varies, depending on how often you do this type of work. To reduce your exposure to these chemicals: Work in a well ventilated area, and work with approved safety equipment, such as those dust masks that are specially designed to filter out microscopic particles.

Table Of Contents

	PAGE
1. INTRODUCTION	2
ABOUT YOUR NEW MORTISING MACHINE	2
WOODSTOCK SERVICE AND SUPPORT.....	2
WARRANTY, RETURNS AND SPECIFICATIONS.....	3
2. SAFETY.....	4
STANDARD SAFETY INSTRUCTIONS.....	4-5
MORTISING MACHINE SAFETY	5
ELECTRICAL REQUIREMENTS	6
AVOIDING POTENTIAL INJURIES	7
3. ASSEMBLY INSTRUCTIONS	8
BOX CONTENTS	8
MOUNTING	9-10
HAND LEVER.....	11
GAS SPRING	12
WORK TABLE	13
FENCE.....	13
HOLD DOWN	14
INSTALLING CHISELS	15
4. ADJUSTMENTS	16
GAS SPRING LOCATIONS.....	16
GAS SPRING PLACEMENT	17
PIVOT FEATURE.....	18
FENCE ADJUSTMENTS.....	18-19
WIDER STOCK.....	19
5. OPERATIONS	20
TEST RUN	20
MAKING A MORTISE.....	20-21
6. MAINTENANCE	22
GENERAL	22
FENCE AND CHISELS.....	22
LUBRICATION	22
7. CLOSURE.....	23
PARTS BREAKDOWN AND PARTS LISTS	24-25
YOUR NOTES.....	26

USE THE QUICK GUIDE PAGE LABELS TO SEARCH OUT INFORMATION FAST!





INTRODUCTION

ABOUT YOUR NEW MORTISING MACHINE

This Shop Fox® Mortising Machine has been specially designed by Woodstock International, Inc. to provide many years of trouble free service. Close attention to detail, ruggedly built parts and a rigid quality control program assure safe and reliable operation.

The Model W1671 Mortising Machine features a 1/2" drill chuck, a quick-setting handle, an adjustable depth stop and a reliable rack and pinion elevation system. Combined with a 3/4 H.P. motor, a safety switch with removable key and a cord set, the Shop Fox® Mortising Machine will give years of satisfying use.

Woodstock International, Inc. is committed to customer satisfaction in providing this manual. It is our intent to make sure all the information necessary for safety, ease of assembly, practical use and durability of this product be included.

If you should have any comments regarding this manual, please feel free to contact us at:

Woodstock International, Inc.
P.O. Box 2309
Bellingham, WA 98227
manuals@woodstockint.com

WOODSTOCK SERVICE AND SUPPORT

We stand behind our machines! In the event that a defect is found, parts are missing or questions arise about your machine, please contact Woodstock International Service and Support at 1-360-734-3482 or tech-support@woodstockint.com. Our knowledgeable staff will help you troubleshoot problems, send out parts or arrange warranty returns.

WARRANTY, RETURNS AND SPECIFICATIONS

Woodstock International, Inc. warrants all SHOP FOX® machinery to be free of defects from workmanship and materials for a period of 2 years from the date of original purchase by the original owner. This warranty does not apply to defects due directly or indirectly to misuse, abuse, negligence or accidents, lack of maintenance, or to repair or alterations made or specifically authorized by anyone other than Woodstock International, Inc.

Woodstock International, Inc. will repair or replace, at its expense and at its option, the SHOP FOX® machine or machine part which in normal use has proven to be defective, provided that the original owner returns the product prepaid to the SHOP FOX® factory service center or authorized repair facility designated by our Bellingham, WA office, with proof of their purchase of the product within 2 years, and provides Woodstock International, Inc. reasonable opportunity to verify the alleged defect through inspection. If it is determined there is no defect, or that the defect resulted from causes not within the scope of Woodstock International Inc.'s warranty, then the original owner must bear the cost of storing and returning the product.

This is Woodstock International, Inc.'s sole written warranty and any and all warranties that may be implied by law, including any merchantability or fitness, for any particular purpose, are hereby limited to the duration of this written warranty. We do not warrant that SHOP FOX® machinery complies with the provisions of any law or acts. In no event shall Woodstock International, Inc.'s liability under this warranty exceed the purchase price paid for the product, and any legal actions brought against Woodstock International, Inc. shall be tried in the State of Washington, County of Whatcom. We shall in no event be liable for death, injuries to persons or property or for incidental, contingent, special or consequential damages arising from the use of our products.

Every effort has been made to ensure that all SHOP FOX® machinery meets high quality and durability standards. We reserve the right to change specifications at any time because of our commitment to continuously improve the quality of our products.

Machine Specifications

Capacities:

Head Travel	9"
Chuck	1/2"
Chisel Shank	5/8" or 3/4"
Hold Down Height	4 1/2", 6 1/2", 8 1/2"

Motor:

Type	TEFC Capacitor Start Induction
Horsepower	3/4 H.P.
Phase / Cycle	Single Phase / 60 Hz
Voltage	110V
Amps	8
R.P.M.	3450
Power Transfer	Direct Drive
Bearings	Sealed & Permanently Lubricated Ball Bearing
Switch	Paddle Safety Switch

SAFETY FIRST!

READ MANUAL BEFORE OPERATING MACHINE FAILURE TO FOLLOW INSTRUCTIONS BELOW WILL RESULT IN PERSONAL INJURY



Indicates an imminently hazardous situation which, if not avoided, **WILL** result in death or serious injury.



Indicates a potentially hazardous situation which, if not avoided, **COULD** result in death or serious injury.



Indicates a potentially hazardous situation which, if not avoided, **MAY** result in minor or moderate injury. It may also be used to alert against unsafe practices.

NOTICE

This symbol is used to alert the user to useful information about proper operation of the equipment.

1. **Thoroughly read the instruction manual before operating your machine.** Learn the applications, limitations and potential hazards of this machine. Keep manual in a safe, convenient place for future reference.
2. **Keep work area clean and well lighted.** Clutter and inadequate lighting invite potential hazards.
3. **Ground all tools.** If a machine is equipped with a three-prong plug, it must be plugged into a three-hole electrical outlet or grounded extension cord. If using an adapter to aid in accommodating a two-hole receptacle, ground using a screw to a known ground.
4. **Wear eye protection at all times.** Use safety glasses with side shields or safety goggles, meeting the national safety standards, while operating this machine.
5. **Avoid dangerous environments.** Do not operate this machine in wet or open flame environments. Airborne dust particles could cause an explosion and severe fire hazard.
6. **Ensure all guards are securely in place and in working condition.**
7. **Make sure switch is in the "OFF" position** before connecting power to machine.
8. **Keep work area clean;** free of clutter, grease, etc.
9. **Keep children and visitors away.** All visitors should be kept a safe distance away while operating unit.
10. **Childproof workshop** with padlocks, master switches or by removing starter keys.
11. **Disconnect machine when cleaning, adjusting or servicing.**
12. **Do not force tool.** The machine will do a safer and better job at the rate for which it was designed.
13. **Use correct tool.** Do not force machine or attachment to do a job for which it was not designed.

14. **Wear proper apparel.** Do not wear loose clothing, neck ties, gloves, jewelry, etc.
15. **Remove adjusting keys and wrenches.** Before turning the machine on, make it a habit to check that all adjusting keys and wrenches have been removed.
16. **Use proper extension cord.** When using an extension cord, make sure it is in good condition. When extension cord is 100' and less in length, use those that are rated Hard Service (grade S) or better, and that have a conductor size of 16 A.W.G. A drop in line voltage, loss of power and overheating can result when using an undersized cord. The extension cord should have a ground wire and ground plug pin, as well.
17. **Keep proper footing and balance** at all times.
18. **Do not leave machine unattended;** wait until it comes to a complete stop before leaving the area.
19. **Perform machine maintenance and care.** Follow lubrication and accessory attachment instructions in the manual.
20. **Keep machine away from open flame.** Operating machines near pilot lights and/or open flames creates a high risk if dust is dispersed in the area. Dust particles and an ignition source may cause an explosion. Do not operate the machine in high risk areas, including but not limited to, those mentioned above.

Additional Safety Instructions For Mortising Machines

1. **Do not use Mortising Machine for anything except mortising in wood.** Materials such as metals, plastics and glass can damage the machine resulting in personal injury.
2. **Do not adjust machine or workpiece while running.** Wait for spindle to come to a complete stop and unplug the machine before continuing.
3. **Do not place your hands near the chisel while spindle is in motion.**
4. **Always wear a respirator and safety glasses while operating mortising machine.** Dust and chips are created when mortising. Some debris will be ejected becoming eye and breathing hazards.
5. **Never use tools that are in poor condition.** Inspect Mortising Machine for free motion of the head casting, loose drill bit/chisel housing, loose nuts/bolts and unusual sounds before connecting machine to power and operating. Correct any problems before use.
6. **Chisels are sharp!** Always use caution when handling, especially when installing or removing.
7. **Never allow hands to be under installed chisel at any time.**
8. **Chisels may become hot during operation.** Allow chisels to cool before handling.
9. **If at any time you are experiencing difficulties performing the intended operation, stop using the machine!** Then contact our service department or ask a qualified expert how the operation should be performed.
10. **Always set depth stop to bottom and lock** before adjusting quick-setting handle or changing air spring locations.
11. **Habits - good and bad - are hard to break.** Develop good habits in your shop and safety will become second-nature to you.

ELECTRICAL REQUIREMENTS

110V Operation

The Shop Fox® W1671 Mortising Machine can only be operated at 110 volts. The motor supplied with your new Mortising Machine is rated at $\frac{3}{4}$ H.P. and will draw approximately 8 amps. When choosing an outlet for this machine, consider using one with a 10 amp circuit breaker or fuse. Keep in mind that a circuit being used by other machines or tools at the same time will add to the electrical load being applied by the Mortising Machine. Add up the load ratings of all machines on the circuit. If this number exceeds the rating of the circuit breaker or fuse, use a different outlet.

Extension Cords

When it is necessary to use an extension cord, use the following guidelines:

- Use cords rated for Hard Service
- Never exceed a length of 100 feet
- Use cords with 14 ga. wire or bigger
- Insure cord has a ground wire and pin
- Do not use cords in need of repair

Grounding

This machine must be grounded! See Figure 1. The electrical cord for the Model W1671 is supplied with a 3 prong plug. If your outlet does not accommodate a ground pin, have it replaced by a qualified electrician or have an appropriate adapter installed and grounded properly. An adapter with a grounding wire does not guarantee the machine will be grounded. The ground source must be verified.

WARNING

This equipment must be grounded. Verify that any existing electrical outlet and circuit you intend to plug into is actually grounded. If it is not, it will be necessary to run a separate 12 A.W.G. copper grounding wire from the outlet to a known ground. Under no circumstances should the grounding pin from any three-pronged plug be removed. Serious injury may occur.

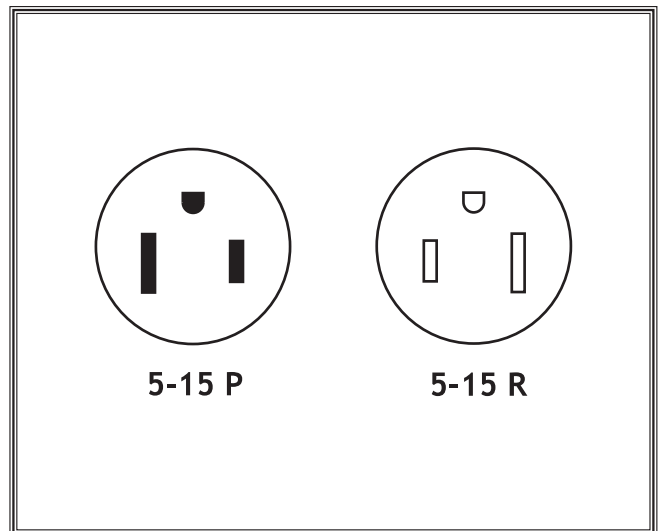
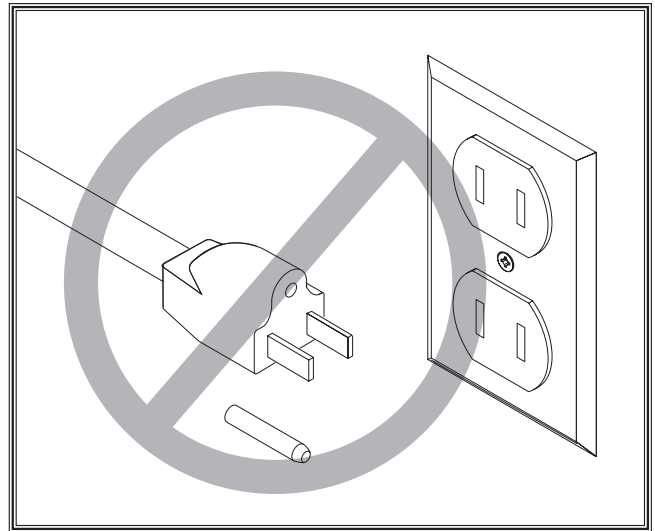

Figure 1. Typical 110V 3-prong plug and outlet.

AVOIDING POTENTIAL INJURIES



Figure 2. Unplug before changing chisels.



Figure 3. Always clamp workpiece.

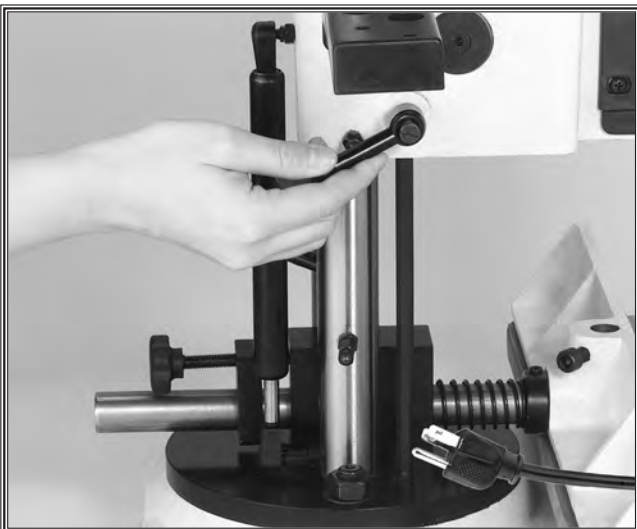

Fig. 4. Secure depth stop before removing gas spring.



Figure 5. Remove safety key when not in use.



Figure 6. Never place hands under chisel.



Fig. 6A. Secure depth stop before adjusting quick-set handle above. See Fig. 4.

ASSEMBLY INSTRUCTIONS

ASSEMBLY

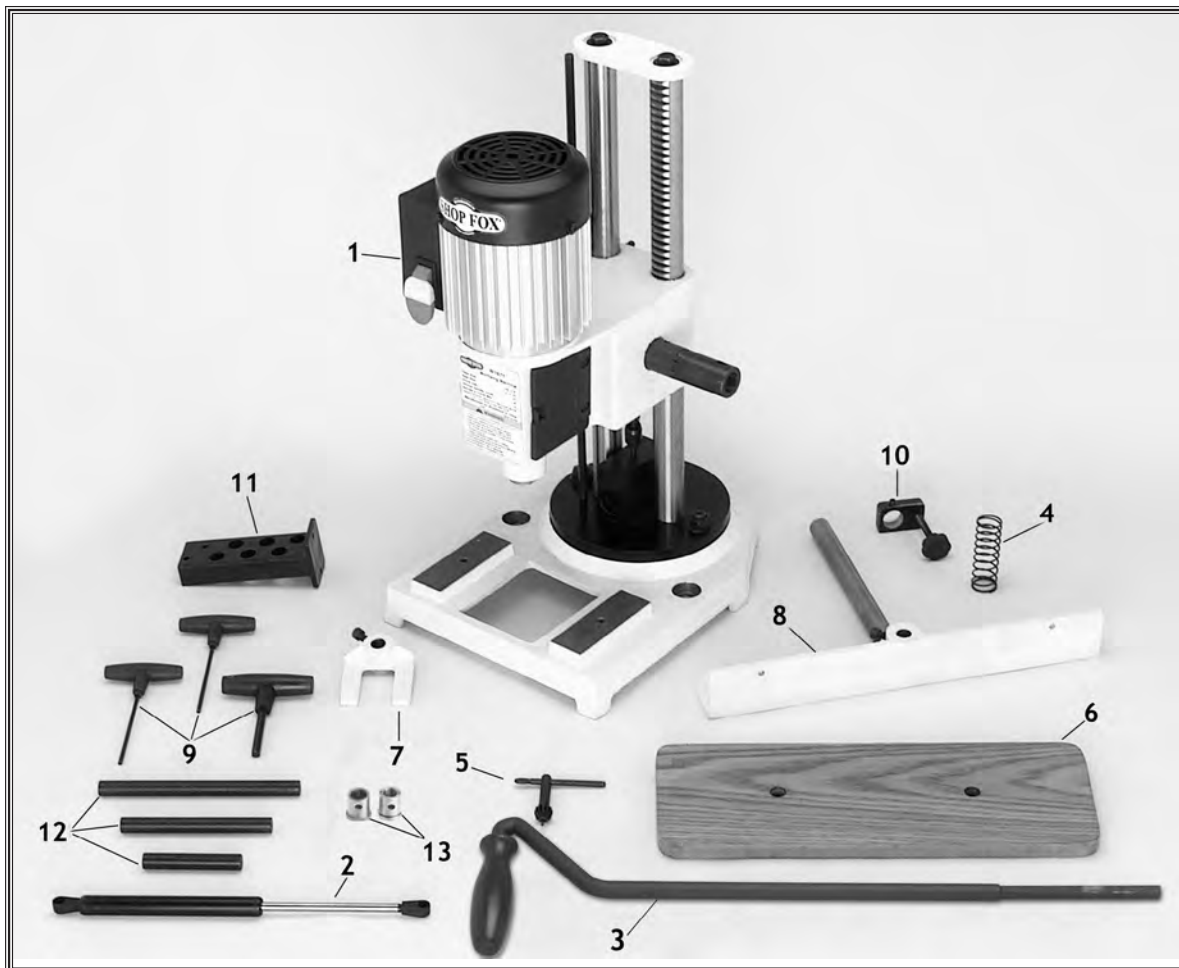

Figure 7. Components laid out for identification.

The following is a description of the components shipped with the Shop Fox® W1671 Mortising Machine. It is recommended that all the parts be laid out in a similar fashion to those in Figure 7. This will help in identification before beginning assembly. Should any part be missing, examine the packaging carefully. If any key parts are missing call Woodstock International, Inc. at 360-734-3482 or contact on the internet at: tech-support@woodstockint.com.

Box Contents

- | | |
|----------------------|-------------------------------------|
| 1. Mortising Machine | 8. Fence |
| 2. Gas Spring | 9. 4mm, 6mm and 8mm Allen® Wrenches |
| 3. Hand Lever | 10. Fine Adjusting Bracket |
| 4. Spring | 11. Tool Tray |
| 5. Chuck Key | 12. Hold Down Rods (3) |
| 6. Wood Table | 13. Chisel Bushings (2) |
| 7. Hold Down | |

While the main mortising assembly of the Shop Fox® W1671 Mortising Machine is assembled at the factory, other components require assembly. The following is the recommended sequence best suited for final assembly.

TOOLS REQUIRED: You will need the 4, 5 & 6mm Allen® wrenches (supplied), a hand drill, a 1/4" or 5/16" drill bit and a Phillips® screw driver.

	<p>! WARNING Wear safety glasses during the entire assembly process. Failure to comply may result in serious personal injury.</p>
--	--

	<p>! WARNING Do not connect the machine to power at this time. The machine must remain unplugged throughout the entire assembly process. Failure to do this may result in serious personal injury.</p>
--	---



Figure 8. Machine positioned near edge of bench.

Mounting

The Model W1671 Mortising Machine can be mounted to any workbench sturdy enough to support the combined weight of the machine and workpiece and which allows a comfortable working height. The bench should be located where plenty of working clearance exists for larger workpieces. The mortising machine must be bolted to the bench, and to help avoid a tipping hazard, *should be bolted away from the front edge*. The mortising machine has a pivoting feature which allows the head and column assembly to pivot around the base. For this reason, the machine should be located near enough to one end of the bench top to allow mortising long workpieces. **See Figure 8.**

Follow the instructions on the next page to mount the mortising machine.

Mounting, Cont.

1. Plan the placement of the mortiser. Take measurements of the base and layout a pencil drawing for the best location on the work bench. See Figure 9.

	<p>CAUTION The Mortiser represents a heavy load that must be lifted from the bottom. Seek assistance before beginning assembly.</p>
--	---

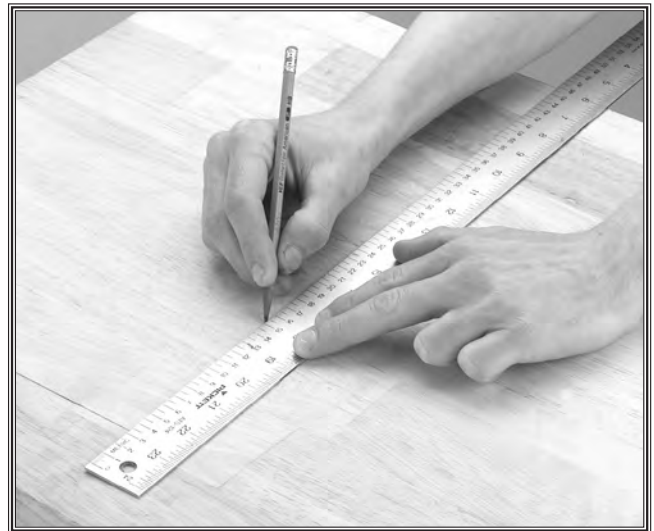

Figure 9. Layout penciled in.

2. Seek assistance and lift the mortising machine to the workbench. *Lift the mortising machine from its base, only.* Slide it over the pencil layout. Recheck for proper working clearance and adjust as needed.

The mortising machine may be secured with $\frac{5}{16}$ " lag bolts or through bolts with washers and nuts (not supplied).

3. Use the mounting holes in the base as drill guides and drill holes. See Figure 10. Drill a $\frac{1}{4}$ " hole for $\frac{5}{16}$ " lag bolts. For through bolts drill a $\frac{5}{16}$ " hole.
4. Secure the base with the bolts.



Figure 10. Using mounting holes as drill guides.

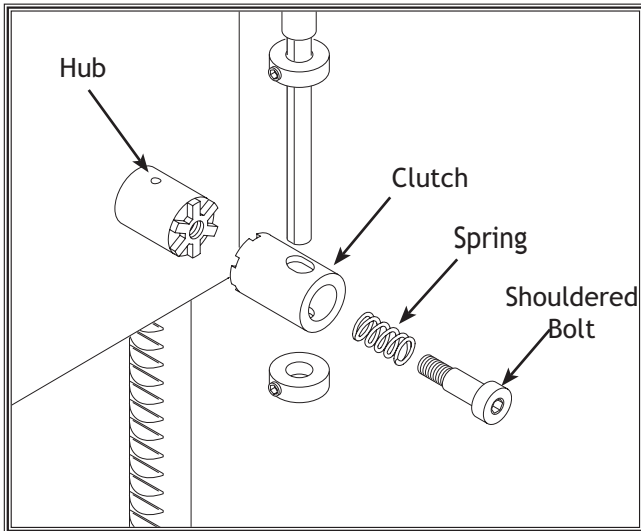
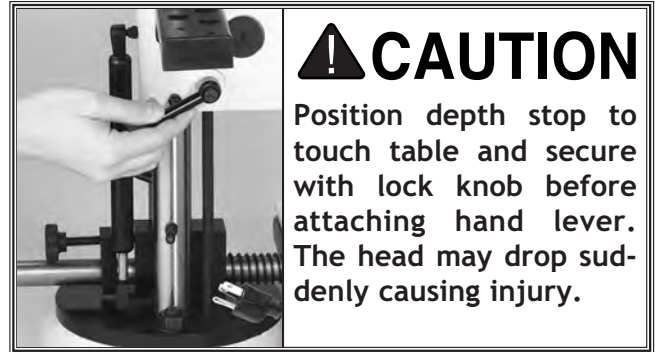

Figure 11. Assembly break down.



Figure 11A. Secure collar onto hand lever.

Hand Lever



CAUTION

Position depth stop to touch table and secure with lock knob before attaching hand lever. The head may drop suddenly causing injury.

Attaching the hand lever requires the use of the 4 and 5mm Allen® wrenches supplied.

1. Locate the shouldered bolt, clutch and small spring.
2. Insert the spring into the clutch and place the clutch on the hub.
3. Secure the spring and clutch using the shouldered bolt. Insert the bolt and tighten. Refer to **Figure 11** for the layout of the parts.
4. Loosen the setscrew securing the collar closest to the end of the hand lever and remove the collar.
5. Insert the end of the hand lever into the *smaller slot* in the clutch. Slide the collar back onto the end of the hand lever and secure by tightening the setscrew. The lower collar should be set below the clutch by 1" to allow working clearances when the lever is swung out for indexing.

The hand lever can be adjusted for height by moving both of the collars up or down. Adjust these collars to accommodate the most comfortable height for operation.

Gas Spring

The gas spring can be secured to 3 different locations along the side or back of the left column. Each location offers a different range of motion for the mortising head. In the instructions below, we will cover only the side location. Further explanation will follow in the **Adjustments** section.



CAUTION

Position depth stop to touch table and secure with lock knob before indexing the hand lever. The head may drop suddenly, causing injury.

1. Adjust the depth stop lever until it touches the table surface.
2. Lift the head using the hand lever. If necessary, index the lever (**Figure 12**) to make multiple turns of the hub so the head moves to its highest elevation. **Be sure to position the depth stop rod so that it touches the base of the machine and lock it in place before indexing the handle. This ensures the weight of the head casting is supported while adjustments are made.**
3. The gas spring ends snap into place over the ball-end junction. It may be necessary to compress the gas spring slightly to align sockets in gas springs with ball-end junction. See **Figure 13**.



Figure 12. Indexing handle by swinging out.

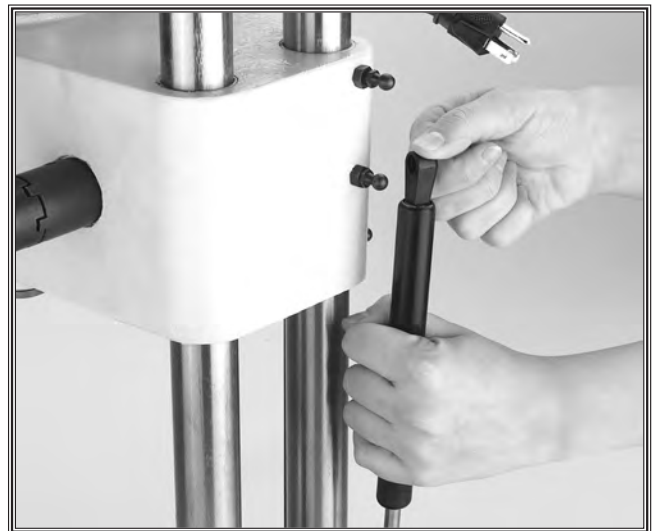

Figure 13. Compressing gas spring to assemble.



Figure 14. Work table secured with screws.

Work Table

1. Secure the wooden work table with the 2 Phillips® head screws provided. See Figure 14.



Figure 15. Slide fence support through block.

Fence

1. The fence comes with a micro-adjustable stop attached to the fence support rod, which retains a spring. Loosen the setscrew with the 4mm Allen® provided and remove the stop but not the spring.
2. Slide the support rod into the mounting block located between the columns. See Figure 15.
3. Replace the micro-adjustable stop and secure with the setscrew. See Figure 16.

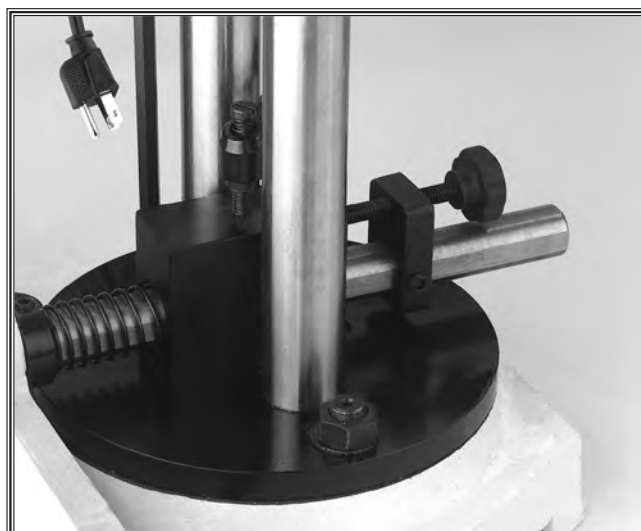

Figure 16. Micro-adjustable stop in position.

Hold Down

The hold down acts as a clamp, holding the workpiece to the table surface. This helps to keep the workpiece from raising when extracting the chisel after a cut is made. **The hold down must be used.**

1. Support the head with the hand lever and unlock the depth stop lock knob. Allow depth stop rod to touch the base surface and secure the rod in place.
2. The hold down support rod has a flat portion along its length. Place the completely round portion into the fence. Do not tighten the screw in the fence at this time.
3. The hold down bracket may be placed on the support rod in two positions. If placed on the support rod as in **Figure 17**, the bracket will hold down a workpiece slightly taller than the fence. When placed in the position shown in **Figure 18**, the bracket will hold down a workpiece that measures $\frac{3}{8}$ " less than the height of the support rod.

There are 3 hold down support rods supplied with the mortising machine. The length of the support rod used will be determined by the height of the workpiece. More information about using the hold down is detailed in the section titled **Adjustments**.

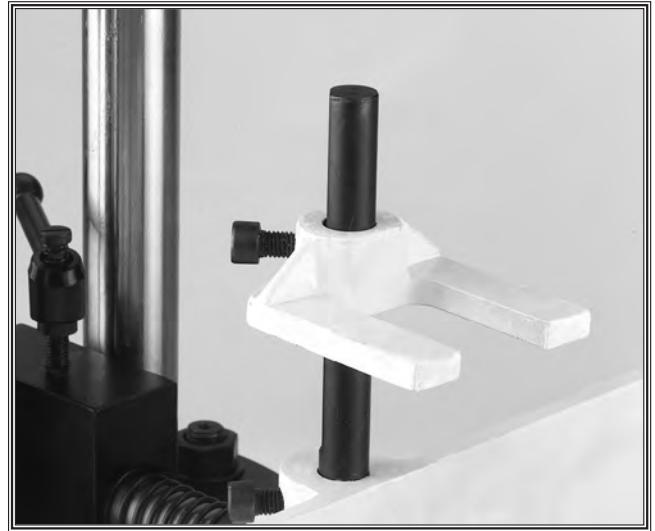

Figure 17. Bracket in the lowest position.

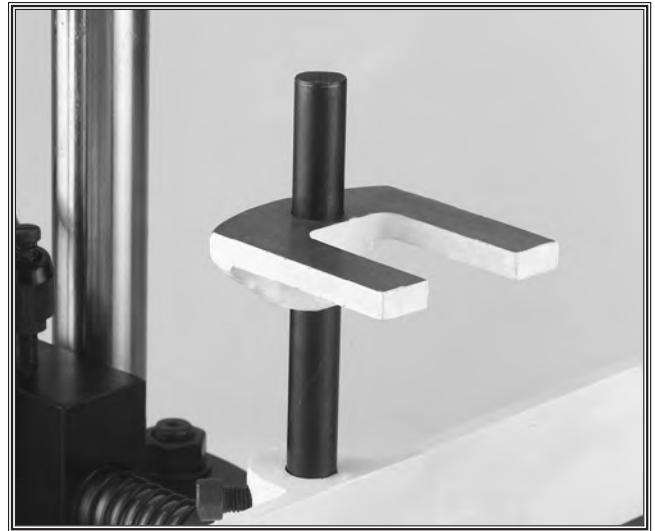

Figure 18. Bracket in the highest position.

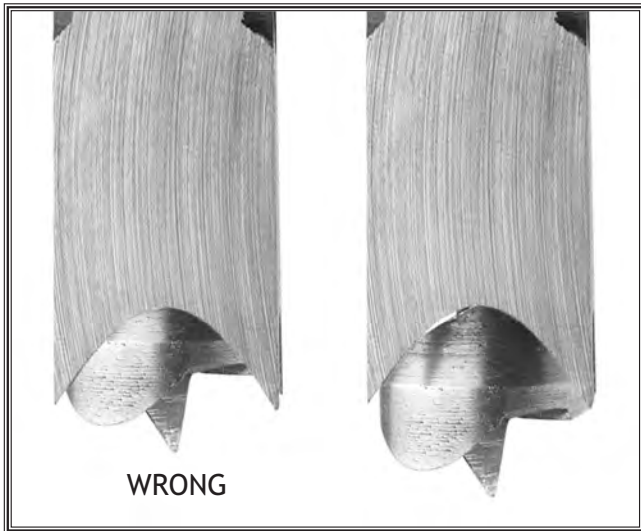
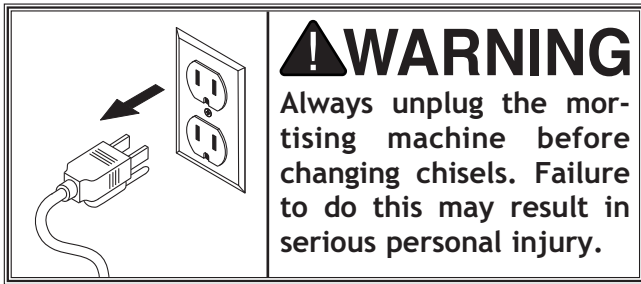

Figure 19. Drill bit must extend beyond chisel.



Figure 20. Back edge of chisel parallel with fence.

Installing Chisels

Select the size needed for your project and follow the instructions below.

1. Support the head with the hand lever and unlock the depth stop lock knob. Allow depth stop rod to touch the base surface and secure the rod in place.
2. Remove the hold down bracket from the support rod and move the fence to the back edge of the work table.
3. **Protect your hands.** Use gloves or wrap a shop towel around the sharp end of the chisel.
4. Slide the end of the chisel housing into the bushing located just under the chuck. **Make sure the opening in the chisel face is away from the operator.**
5. Tighten the cap screw to the side of the chisel mount with the 5mm Allen® wrench provided.
6. Tighten the drill bit into the drill chuck with the chuck key provided. Make sure the drilling end of the drill bit is positioned just outside the end of the chisel housing. **See Figure 19.**
7. Place a straight, tall board against the fence and adjust the fence until the board touches the back edge of the chisel. Tighten the lock handle for the fence.
8. Loosen the cap screw holding the chisel housing and rotate the chisel until the back surface is parallel-with the board. **See Figure 20.** Tighten the cap screw.

ADJUSTMENTS

Gas Spring Locations

The gas spring can be positioned in 1 of 3 locations to allow clearance for different board thicknesses or to mortise a board on edge. To determine which setting to use, look at the chart in **Figure 21** and find the board thickness that most closely fits your workpiece. Note the number that corresponds with that board. This will be the position number shown in **Figure 22**. Follow the instructions on the following page to place the gas spring in the new location.

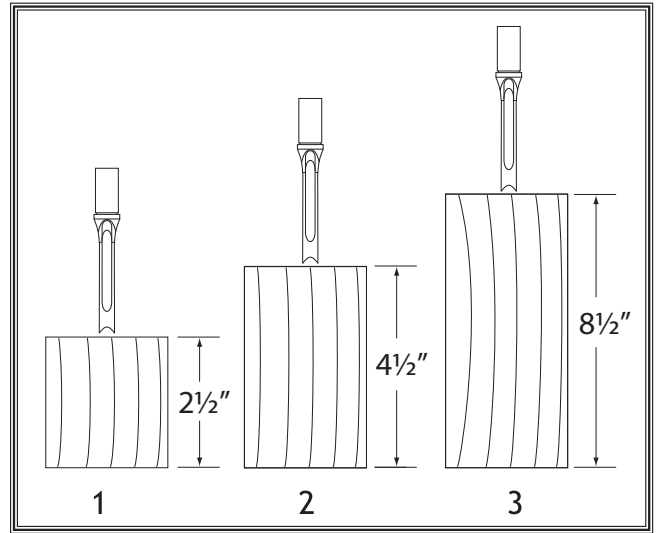

Figure 21. Maximum board thicknesses.

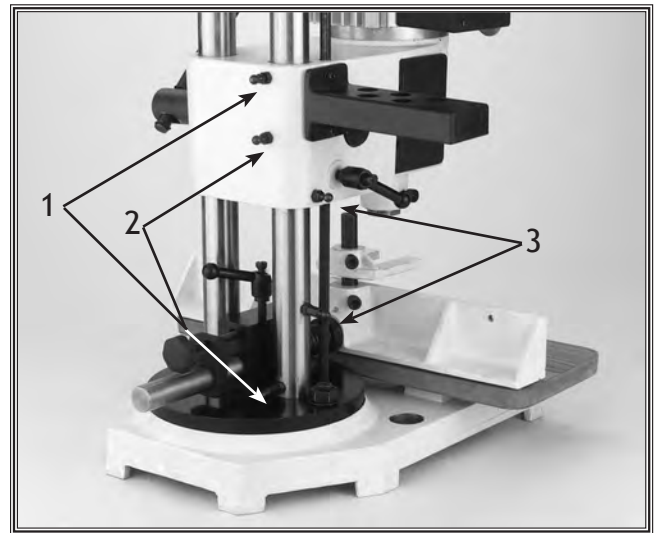

Figure 22. Gas spring positions.

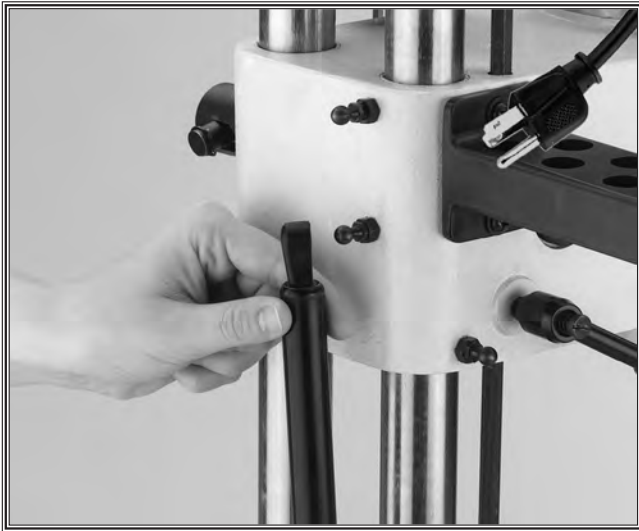



Figure 23. Snapping gas spring into place.

Gas Spring Placement

Swinging the handle out will cause the head casting to fall when the gas spring is removed. The gas spring supports the weight of the head casting and the hand lever regulates its height. However, if the handle is pulled while the gas spring is removed the head will drop suddenly. Please read the **Caution** to the left.

Upon determining which location the gas spring is to be placed, follow the instructions below.

1. Support the head with the hand lever and unlock the depth stop lock knob. Allow the depth stop rod to touch the base surface and secure the depth stop rod in place.
2. The gas spring ends will snap off of the ball end junctions. Remove the gas spring.
3. Snap the gas spring into place over the desired ball-end junction locations. See **Figure 23**. It may be necessary to compress gas spring slightly or to further lift or lower the head using the handle to align the sockets in the gas springs with the ball-end junctions.



⚠ CAUTION

Position depth stop rod to touch table and secure with lock knob before removing the gas spring. The head may drop suddenly, causing injury.



⚠ WARNING

Never make adjustments to the head when a chisel is installed into the mortising machine. Serious injury will occur if the head drops suddenly.

Pivot Feature

The head and column assembly can be adjusted for mortising off of the base. This will allow the mortising machine to accommodate a larger workpiece than those previously listed. To change the position of the head and column assembly:

1. Support the head with the hand lever and unlock the depth stop lock knob. Allow the depth stop rod to touch the base surface and secure the rod in place.
2. Loosen the two hex nuts in the pivoting base.
3. Rotate the assembly to the desired angle.
4. Tighten the hex nuts.
5. The worktable should be removed before operating the machine.

Secure the workpiece with clamps before using the machine. See Figure 24.

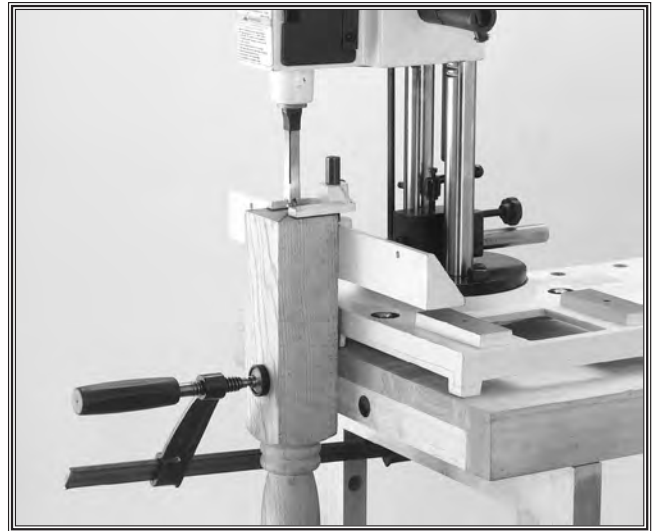

Figure 24. Workpiece clamped to edge of table.

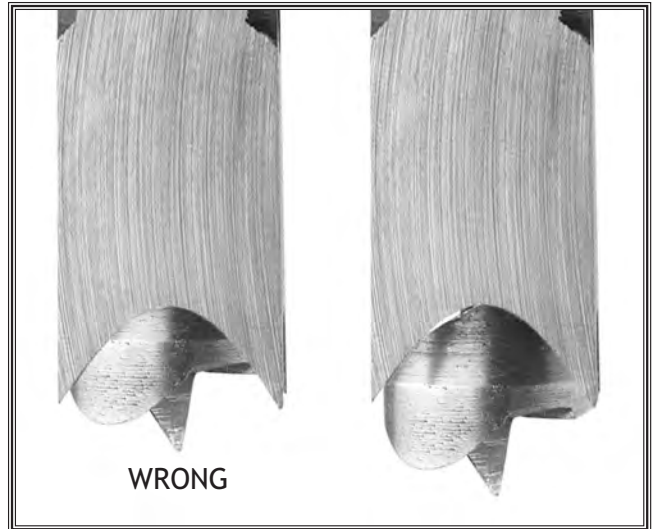

Figure 25. Drill bit must extend beyond chisel.



Figure 26. Setting micro-adjusting block.

Fence Adjustments

The fence is supplied with a fine adjusting assembly, a spring and a collar. These enable centering the chisel to the workpiece quickly and with accuracy.

1. Support the head with the hand lever and unlock the depth stop lock knob. Allow depth the stop rod to touch the base surface and secure the rod in place.
2. Loosen the locking lever for the fence.
3. Use a pencil to mark the mortise on the workpiece.
4. Install the mortising chisel with the drill bit. The drill bit must be positioned so the end extends beyond the chisel body for proper chip clearance. See Figure 25.

ADJUSTMENTS

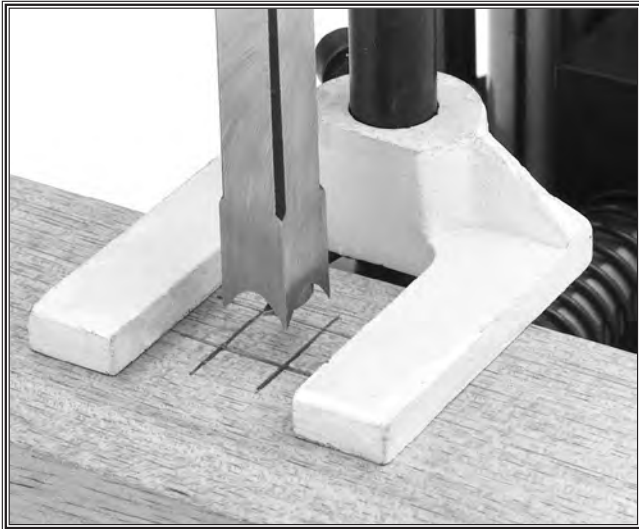

Figure 27. Aligning chisel to marked workpiece.



Figure 28. Repositioning the support block.

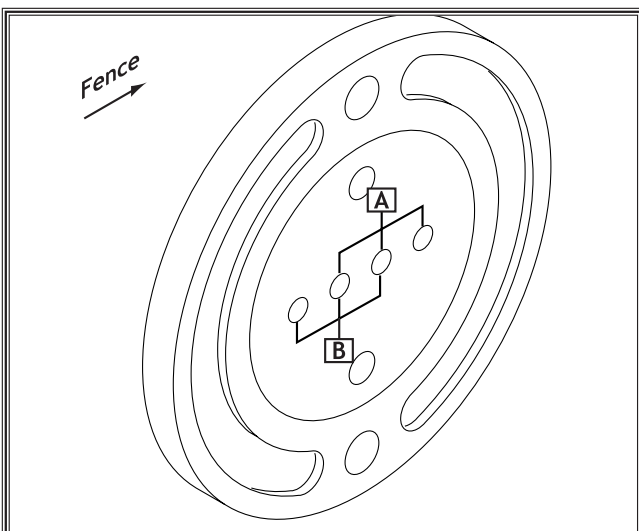

Figure 29. Support block locations.

5. Place the workpiece against the fence and position the fence so the chisel is near the penciled in marks. Lock the fence.
6. Loosen the setscrew holding the micro adjustment block on the fence mounting rod and move the block until the screw fits into the back of the support block. See Figure 26 on the previous page.
7. Unlock the fence and rotate the micro adjustable knob until the chisel lines up with the penciled in lines as in Figure 27.

Wider Stock

1. Remove the mortising chisel and drill bit.
2. Loosen and remove the 2 hex nuts on the top of the pivot base.
3. Carefully lift the head stock assembly until pivot base clears the locking studs. Lay the assembly on its side on the workbench.
4. Remove the 3 cap screws holding the support block to the pivot base as in Figure 28.

Note that the support block is in position A (in Figure 29) when the block is closest to the fence and position B when the block is furthest from the fence.

5. Reposition the support block to position B.
6. Reattach the support block with the 3 cap screws.

Reattach the head casting assembly and follow the instructions above for fence and workpiece setup.

OPERATIONS

Test Run

Once assembly is complete and adjustments are done to your satisfaction, you are ready to test run the machine.

	<p>⚠ WARNING Always wear safety glasses when operating this Mortising Machine. Failure to comply may result in serious personal injury.</p>
---	--

Make sure the starting switch is off. The paddle is down for off. Make sure all the fasteners and lock handles are tight. Plug in the power cord. Pull the START paddle. Make sure that your finger is poised over the paddle, **Figure 30**, just in case there is a problem. The Mortising Machine should run smoothly, with little or no vibration or rubbing noises. Normally, there is some noise generated by the drill bit turning inside the chisel. If noise is excessive, it is likely the drill bit needs to be lowered a little inside the chisel. Any strange or unnatural noises require you to stop the machine, wait for it to stop moving, unplug the machine, investigate and correct the problem before further operation.

If the source of an unusual noise or vibration is not readily apparent, please contact our service department for help at 1-360-734-3482 or by email at: tech-support@woodstockint.com.

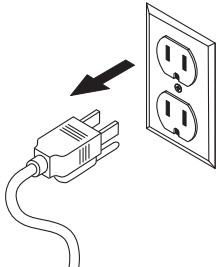

Figure 30. Hand poised over stop paddle.

	<p>⚠ WARNING DO NOT attempt to investigate or adjust the machine while it is running. Wait until the machine is turned off, unplugged and all working parts have come to a stop before proceeding!</p>
---	---

Making A Mortise

1. Support the head with the hand lever and unlock the depth stop lock knob. Allow the depth stop rod to touch the base surface and secure the rod in place.
2. Check the set up of the mortising machine to ensure head height and range of motion is sufficient. Also, check fasteners and locks.
3. Adjust the depth stop rod to correct depth for producing blind mortises. In **Figure 31**,

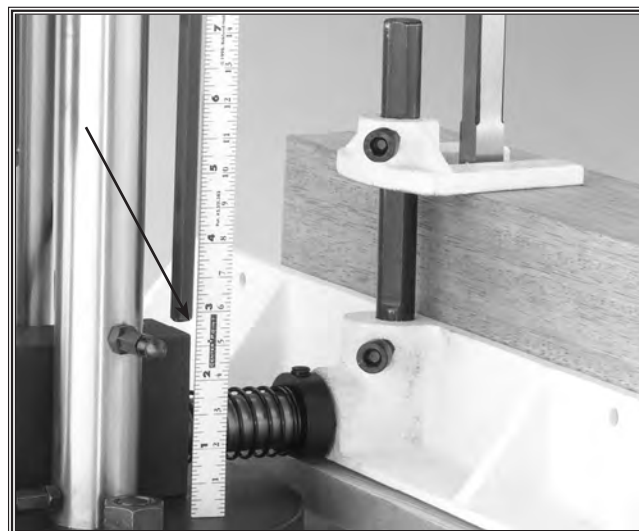

Figure 31. Setting the depth stop to $2\frac{7}{8}$ \".

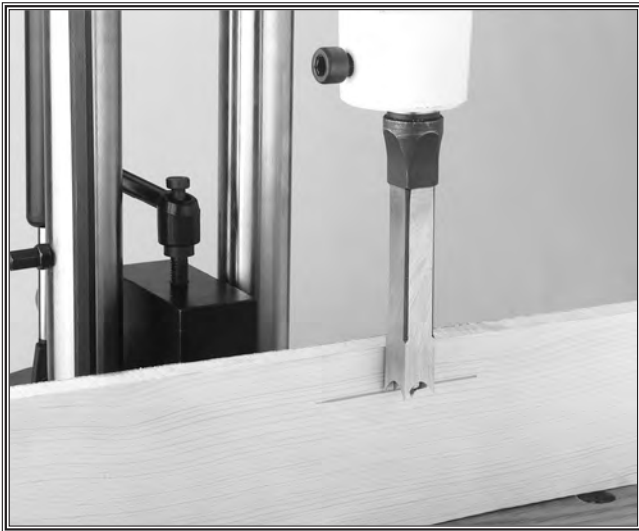
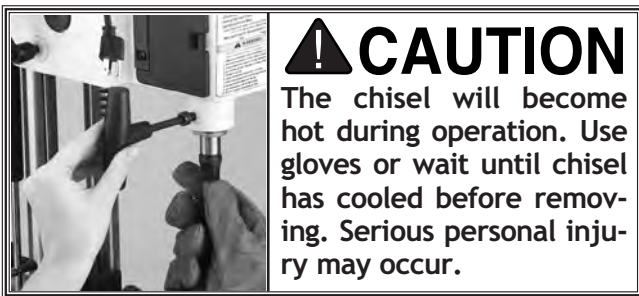

Figure 32. Use penciled line to gauge depth.



CAUTION
 The chisel will become hot during operation. Use gloves or wait until chisel has cooled before removing. Serious personal injury may occur.

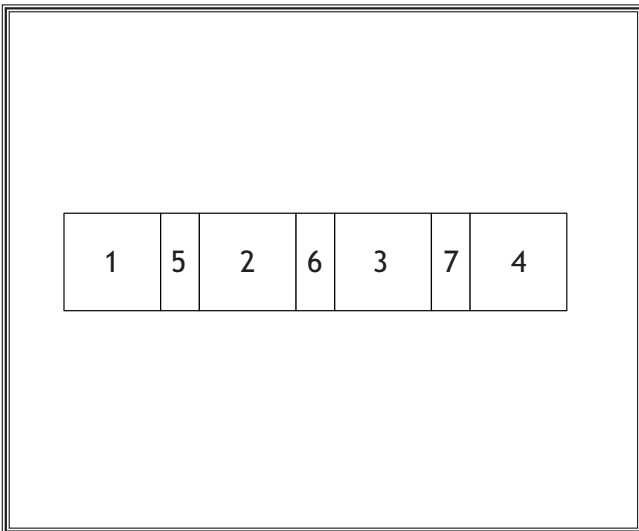

Figure 33. Sequence of cuts.

the head is lowered so the chisel rests on the workpiece. The depth stop rod is adjusted using a measuring tape, to the desired depth. **Figure 32** shows the chisel being lowered until the chisel is even with a depth line on the workpiece. The fence is adjusted before and after the depth stop is locked.

4. Carefully mark the outline of the mortise on the workpiece. Align the fence and workpiece so the chisel aligns with the markings. **See section on Fence Adjustments.** A *sacrificial board* should be used under the workpiece whenever through-holes are produced to minimize tear out and protect the work table.
5. Test the positioning setup with a piece of scrap lumber of the same dimensions as the workpiece. Position the hold down on top of the workpiece and secure with cap screw. **Do Not mortise without a hold down.**
6. Turn the power ON.
7. Lower the head by pulling the hand lever down with your right hand. Be sure not to feed the chisel too fast or too slow. Feeding too fast can cause the drill bit to clog with chips causing the motor to slow down and overheat. Feeding too slow may cause excessive heat, ruining the chisel. However, it is normal for some discoloring of the chisel to occur due to heat generated during use.
8. When desired depth is achieved, move the hand lever back to its original position. The workpiece should remain in place as this is done.
9. Check the placement of hole on the test piece and adjust the fence if necessary. Continue with the actual workpiece when the desired accuracy of placement is achieved.
10. When making rectangular mortises, we recommend you follow the sequence of cuts shown in **Figure 33**. Please note that cuts 5, 6 and 7 will only use a portion of the chisel and so the chisel should be positioned over the center of each space.

MAINTENANCE

General

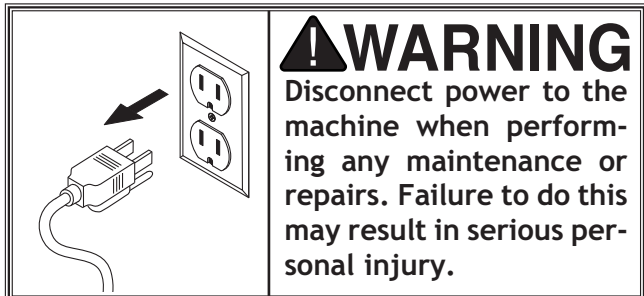

Regular periodic maintenance on your Model W1671 Mortising Machine will ensure its optimum performance. Make a habit of inspecting the machine each time you use it. Check for the following conditions and repair or replace when necessary.

1. Loose mounting bolts.
2. Worn switch.
3. Worn or damaged cords and plugs.
4. Any other condition that could hamper the safe operation of this machine.

Fence And Chisels

The cast iron fence and steel chisels/bits can be kept rust-free with regular applications of products like Boeshield® T-9. For long term storage you may want to consider products like Kleen Bore's Rust Guardit™.

Lubrication

Since all bearings are sealed and permanently lubricated, simply leave them alone until they need to be replaced. Do not lubricate them.

For other items on this machine, such as the gear, base and columns, an occasional application of light machine oil is all that is necessary. Before applying lubricant, clean off sawdust and wood chips.

Your goal is to achieve adequate lubrication. Too much lubrication will attract dirt and sawdust. Various parts of your machine could lose their freedom of movement as a result.

Lubricating Drill Bits

The drill bits for mortising chisels operate under extreme conditions. A small amount of bees wax applied to the drill bit can aid in reducing heat and expelling chips. It is important that a small amount is used and none is applied to the chisel. Bees wax coming into contact with the finished surfaces will impede adhesion of glues and finishes.

CLOSURE

The following pages contain general machine parts diagrams/lists and warranty/return information for your Shop Fox® Model W1671 Mortising Machine.

If you need parts or help in assembling your machine, or if you need operational information, we encourage you to call our service department. Our trained service technicians will be glad to help you.

If you have comments dealing specifically with this manual, please write to us using the address in the General Information. The specifications, drawings, and photographs illustrated in this manual represent the Model W1671 as supplied when the manual was prepared. However, due to Woodstock International, Inc.'s policy of continuous improvement, changes may be made at any time with no obligation on the part of Woodstock International, Inc. Whenever possible, though, we send manual updates to all owners of a particular tool or machine. Should you receive one, add the new information to this manual and keep it for reference.

We have included some important safety measures that are essential to this machine's operation. While most safety measures are generally universal, we remind you that each workshop is different and safety rules should be considered as they apply to your specific situation.

We recommend you keep this manual for complete information regarding Woodstock International, Inc.'s warranty and return policy. If you need additional technical information relating to this machine, or if you need general assistance or replacement parts, please contact the Service Department at 360-734-3482 or tech-support@woodstockint.com on the internet.

Additional information sources are necessary to realize the full potential of this machine. Trade journals, woodworking magazines, and your local library are good places to start. The Model W1671 was specifically designed for

! WARNING

As with all power tools, there is danger associated with the Model W1671 Mortising Machine. Use the tool with respect and caution to lessen the possibility of mechanical damage or operator injury. If normal safety precautions are overlooked or ignored, injury to the operator or others in the area is likely.

mortising operations. **DO NOT MODIFY AND/OR USE THIS MORTISING MACHINE FOR ANY OTHER PURPOSE.** Modifications or improper use of this tool will void the warranty. If you are confused about any aspect of this machine, **DO NOT** use it until all your questions have been answered.



! WARNING
 Keep your shop "Child Safe." Always remove the switch safety key when Mortising Machine is not in use. Serious injury may occur.

MAINTENANCE

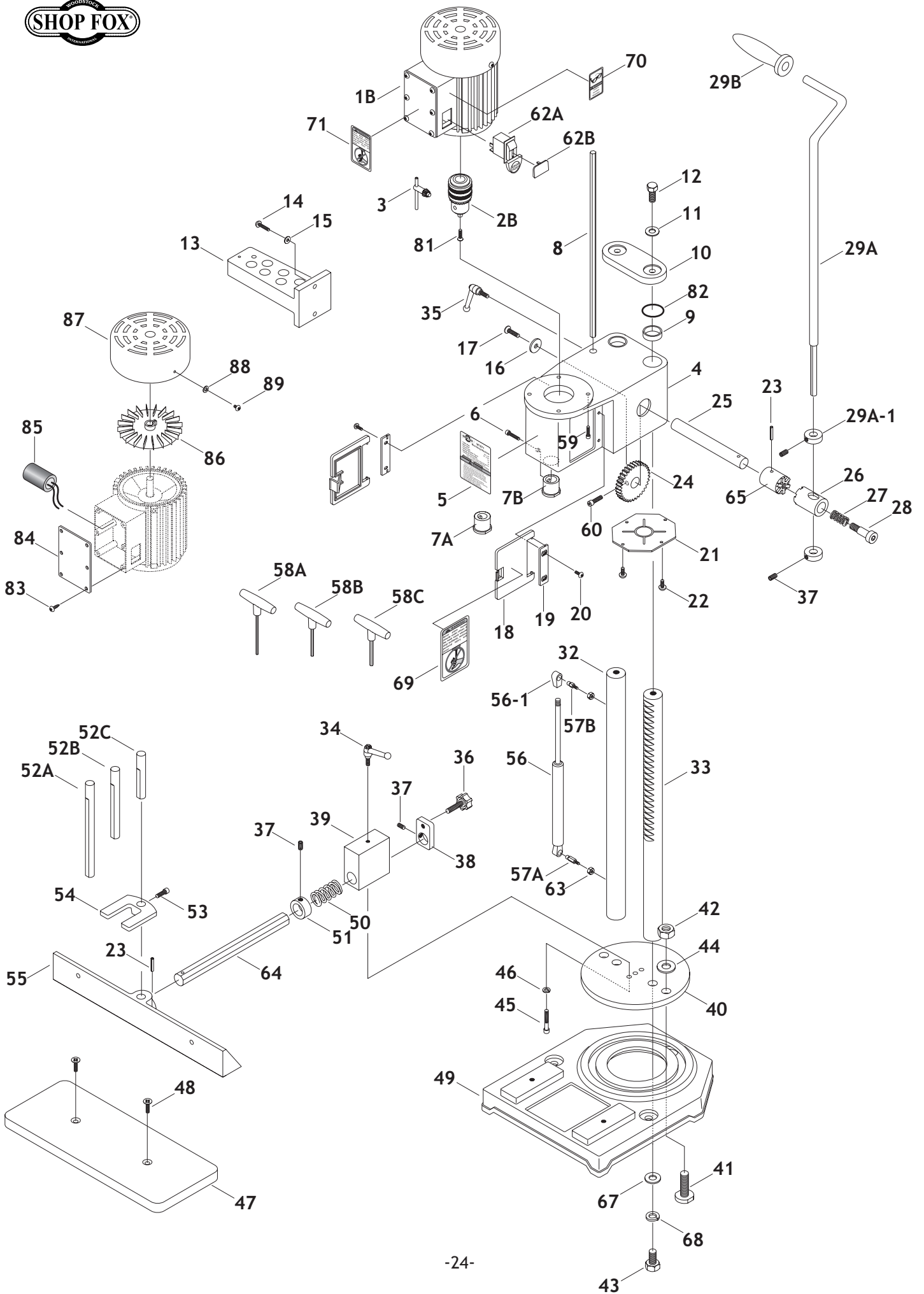

REF	PART #	DESCRIPTION
01B	X1671001B	MOTOR
02B	X1671002B	CHUCK JT MOUNT
3	X1671003	CHUCK KEY
4	X1671004	HEAD CASTING
5	X1671005	LABEL
6	XPSB14M	CAP SCREW M8-1.25 X 20
07A	X1671007A	5/8" BUSHING
07B	X1671007B	3/4" BUSHING
8	X1671008	DEPTH STOP ROD
9	X1671009	GUIDE BUSHING
10	X1671010	STOP PLATE
11	XPW04M	FLAT WASHER 10MM
12	XPB32M	HEX BOLT M10-1.5 X 25
13	X1671013	HOLDER
14	XPS14M	PHLP HD SCR M6-1 X 12
15	XPW03M	FLAT WASHER 6MM
16	X1671016	SPECIAL WASHER 6MM
17	XPFH02M	FLAT HD SCR M6-1 X 12
18	X1671018	COVER
19	X1671019	HINGE
20	XPS09M	PHLP HD SCR 5-.8 X 10
21	X1671021	COVER PLATE
22	XPS02M	PHLP HD SCR M4-.7 X 12
23	XPRP05M	ROLL PIN 5 X 30
24	X1671024	GEAR
25	X1671025	GEAR SHAFT
26	X1671026	CLUTCH COLLAR
27	X1671027	SPRING
28V2	X1671028V2	SHOULDER BOLT M10-1.5 X 28 V2.11.11
29A	X1671029A	HANDLE
29A-1	X1671029A-1	STOP COLLAR
29B	X1671029B	HAND GRIP
32	X1671032	COLUMN
33	X1671033	RACK COLUMN
34	X1671034	LOCK KNOB M8-1.25 X 35
35	X1671035	LOCK KNOB M8-1.25 X 20
36	X1671036	KNOB M8-1.25 X 56
37	XPSS16M	SETSCREW M8-1.25 X 10
38	X1671038	STOP BRACKET
39	X1671039	GUIDE BRACKET
40	X1671040	ROTARY TABLE TOP
41	X1671041	STUD
42	XPN25M	HEX NUT M14-2
43	XPB32M	HEX BOLT M10-1.5 X 25

REF	PART #	DESCRIPTION
44	XPW16	FLAT WASHER 9/16"
45	XPSB13M	CAP SCREW M10-1.5 X 25
46	XPLW04M	LOCK WASHER 8MM
47	X1671047	TABLE
48	XPFH21M	FLAT HD SCR M8-1.25 X 25
49	X1671049	BASE
50	X1671050	SPRING
51	X1671051	COLLAR
52A	X1671052A	ROD
52B	X1671052B	ROD
52C	X1671052C	ROD
53	XPSB14M	CAP SCREW M8-1.25 X 20
54	X1671054	HOLD DOWN
55	X1671055	FENCE
56	X1671056	GAS SPRING
56-1	X1671056-1	GAS SPRING END
57A	X1671057A	LOWER JUNCTION SCREW
57B	X1671057B	UPPER JUNCTION SCREW
58A	XPAW04M	ALLEN WRENCH 4MM
58B	XPAW05M	ALLEN WRENCH 5MM
58C	X1671058C	ALLEN WRENCH 6MM
59	XPSB06M	CAP SCREW M6-1 X 25
60	XPSB31M	CAP SCREW M8-1.25 X 25
62A	X1671062A	SWITCH
62B	X1671062B	SWITCH KEY
63	XPN01M	HEX NUT M6-1
64	X1671064	FENCE SUPPORT ROD
65	X1671065	CLUTCH
67	XPW04M	FLAT WASHER 10MM
68	XPLW06M	LOCK WASHER 10MM
69	X1671069	HAND/CHISEL WARNING
70	X1671070	SAFETY GLASSES WARNING
71	X1671071	DEPTH STOP WARNING
80	X1671080	COLLAR
81	XPFH06M	FLAT HD SCR M6-1 X 20
82	X1671082	O-RING 32 X 3
83	X1671083	WOOD SCREW M3 X 12
84	X1671084	LID
85	X1671085	CAPACITOR 30 MFD
86	X1671086	MOTOR FAN
87	X1671087	FAN COVER
88	XPW02M	FLAT WASHER 5MM
89	XPS05M	PHLP HD SCR M5-.8 X 8MM



Your Notes:

WARRANTY CARD

Name _____
Street _____
City _____ State _____ Zip _____
Phone Number _____ E-Mail _____ FAX _____
MODEL # _____ SERIAL # _____

The following information is given on a voluntary basis and is strictly confidential.

CUT ALONG DOTTED LINE

- Where did you purchase your Shop Fox® machine?

- How did you first learn about us?
___Advertisement ___Friend
___Mail order Catalog ___Local Store
___World Wide Web Site
___Other _____
- Which of the following magazines do you subscribe to.
___American Woodworker ___Today's Homeowner
___Cabinetmaker ___WOOD
___Family Handyman ___Wooden Boat
___Fine Homebuilding ___Woodshop News
___Fine Woodworking ___Woodsmith
___Home Handyman ___Woodwork
___Journal of Light Construction ___Woodworker
___Old House Journal ___Woodworker's Journal
___Popular Mechanics ___Workbench
___Popular Science ___American How-To
___Popular Woodworking
___Other _____
- Which of the following woodworking/remodeling shows do you watch?
___Backyard America ___The New Yankee Workshop
___Home Time ___This Old House
___The American Woodworker ___Woodwright's Shop
___Other _____
- What is your annual household income?
___\$20,000-\$29,999 ___\$60,000-\$69,999
___\$30,000-\$39,999 ___\$70,000-\$79,999
___\$40,000-\$49,999 ___\$80,000-\$89,999
___\$50,000-\$59,999 ___\$90,000 +
- What is your age group?
___20-29 ___50-59
___30-39 ___60-69
___40-49 ___70 +
- How long have you been a woodworker?
___0 - 2 Years ___8 - 20 Years
___2 - 8 Years ___20+ Years
- How would you rank your woodworking skills?
___Simple ___Advanced
___Intermediate ___Master Craftsman
- How many Shop Fox® machines do you own? _____
- What stationary woodworking tools do you own? Check all that apply.
___Air Compressor ___Panel Saw
___Band Saw ___Planer
___Mortising Machine ___Power Feeder
___Drum Sander ___Radial Arm Saw
___Dust Collector ___Shaper
___Horizontal Boring Machine ___Spindle Sander
___Jointer ___Table Saw
___Lathe ___Vacuum Veneer Press
___Mortiser ___Wide Belt Sander
___Other _____
- Which benchtop tools do you own? Check all that apply.
___1" x 42" Belt Sander ___6" - 8" Grinder
___5" - 8" Drill Press ___Mini Lathe
___8" Table Saw ___10" - 12" Thickness Planer
___8" - 10" Bandsaw ___Scroll Saw
___Disc/Belt Sander ___Spindle/Belt Sander
___Mini Jointer
___Other _____
- Which portable/hand held power tools do you own? Check all that apply.
___Belt Sander ___Orbital Sander
___Biscuit Joiner ___Palm Sander
___Circular Saw ___Portable Planer
___Detail Sander ___Saber Saw
___Drill/Driver ___Reciprocating Saw
___Miter Saw ___Router
___Other _____
- What machines/supplies would you like to see?

- What new accessories would you like Woodstock International to carry?

- Do you think your purchase represents good value?
___Yes ___No
- Would you recommend Shop Fox® products to a friend?
___Yes ___No
- Comments: _____

FOLD ALONG DOTTED LINE

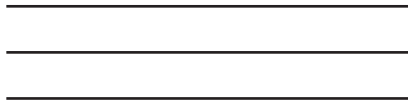

Place
Stamp
Here



WOODSTOCK INTERNATIONAL, INC.
P.O. BOX 2309
BELLINGHAM, WA 98227-2309



FOLD ALONG DOTTED LINE

TAPE ALONG EDGES--PLEASE DO NOT STAPLE

