

WARING PRO[®]

PROFESSIONAL BELGIAN WAFFLE MAKER

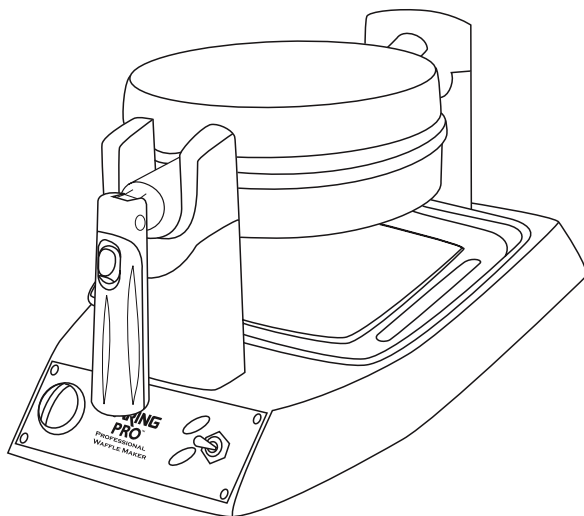

WMK300A

For your safety and continued enjoyment of this product,
always read the instruction book carefully before using.

CONTENTS

Important Safeguards	1
Instructions for Use	3
Special Features.....	5
Tips and Toppings	6
Recipes.....	7
Cleaning and Maintenance	14

IMPORTANT SAFEGUARDS

When using electrical appliances, basic safety precautions should always be followed, including the following:

1. **READ ALL INSTRUCTIONS.**
2. Do not touch hot surfaces. Use handles and knobs.
3. To protect against fire, electrical shock, and injury to persons, **DO NOT IMMERS**E CORD, PLUG, OR UNIT in water or other liquids.
4. Close supervision is necessary when any appliance is used by or near children.
5. Unplug from outlet when not in use and before cleaning. Allow to cool before putting on or taking off parts, and before cleaning appliance.
6. Do not operate any appliance with a damaged cord or plug or after the appliance malfunctions or has been damaged in any manner. Return appliance to the nearest **Waring Authorized Service Facility** for examination, repair, or adjustment.
7. The use of accessory attachments not recommended by Waring may result in fire, electrical shock, or injury to persons.
8. Do not use outdoors, or use for other than intended use.
9. Do not let power cord hang over edge of table or counter, or touch hot surfaces.

10. Do not place on or near a hot gas or electric burner, or in a heated oven.
11. Unplug the unit when finished baking waffles.
12. Always begin by plugging appliance into wall outlet. To disconnect, turn control to setting #1, then remove plug from wall outlet.
13. **WARNING; TO REDUCE THE RISK OF FIRE OR ELECTRIC SHOCK, REPAIR SHOULD BE DONE ONLY BY AUTHORIZED PERSONNEL. DO NOT REMOVE THE BASE PANEL. NO USER SERVICEABLE PARTS ARE INSIDE.**

SAVE THESE INSTRUCTIONS FOR HOUSEHOLD USE ONLY

GROUNDING INSTRUCTIONS

For your protection, the Waring Pro® Professional Waffle Maker is supplied with a molded 3-prong grounding-type plug and should be used in combination with a properly connected grounding-type outlet as shown in the figure.

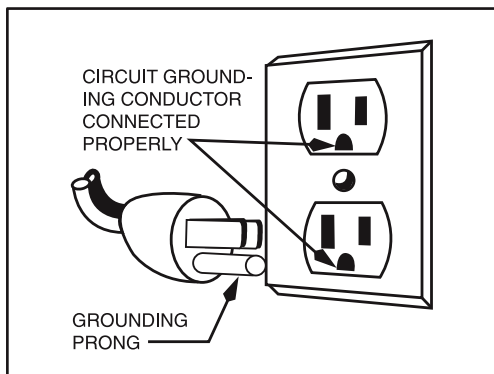

SPECIAL CORD SET INSTRUCTIONS

A short power-supply cord is provided to reduce the risks resulting from becoming entangled in or tripping over a longer cord. Longer extension cords are available and may be used if care is exercised in their use.

If a long extension cord is used, the marked electrical rating of the extension cord should be at least as great

as the electrical rating of the appliance, and the longer cord should be arranged so that it will not drape over the countertop or tabletop where it can be pulled on by children or animals, or tripped over.

INSTRUCTIONS FOR USE

1. Before using your Waring Pro® Professional Belgian Waffle Maker for the first time, remove any dust from shipping by wiping the plates with a damp cloth. Remove all protective paper and wrapping.
2. Plug cord into 120V AC wall or outlet. Switch the toggle switch to the On position. The red light will go on to signal power. The waffle maker will now begin the preheating process. This should take about 4 minutes. The waffle maker will sound 6 beeps and the green indicator light will go on to signal the unit is ready for baking. Season the waffle grids by spraying with cooking spray or brushing with a flavorless oil.

For initial use, it is important that the waffle maker is preheated before seasoning with cooking spray or oil.

NOTE: The first time you use your waffle maker, it may have a slight odor and may smoke a bit. This is normal, and common to heating appliances.

3. Push slide button on handle into up position to extend the handle for baking waffles. When baking is completed, push button on handle into down position to collapse handle for compact storage
4. Preheat your Waring Pro® Belgian Waffle Maker on setting #4 or preferred setting (green indicator light will be illuminated when preheated).
For best results, do not open waffle maker during cooking process. Doing so will offset the timing mechanism.

5. Using the recipes provided (fill measuring scoop to fill line $\frac{3}{4}$ or to top of measuring scoop depending on the recipe. For loose batters, fill to the $\frac{3}{4}$ mark; for thicker batters fill to the top) and pour batter evenly into the center of the waffle grids. Use a heatproof spatula to spread the batter evenly over the grids. Close the lid and rotate the unit 180° to the right.
6. When the waffle is completely baked, the waffle maker will sound 3 beeps. Baking time is determined by browning level. Choose a setting on the browning control dial. For golden brown waffles, we recommend using setting #4.
7. Once the waffle is ready and the waffle maker has beeped 3 times, rotate the waffle maker 180° to the left, open the lid and remove waffle by gently loosening the edges with a heatproof plastic spatula. Never use metal utensils, as they may damage the nonstick coating.
8. Always disconnect the plug from the wall outlet, once baking has been completed.

SPECIAL FEATURES

1. **Deep ½" Waffle Grids**
2. **Browning Control Adjustment**
Adjustable for different batters and personal preference.
3. **Indicator Lights**
 - Red signal indicates waffle maker is in On position.
 - Green signal indicates waffle maker is ready to bake.
4. **Indicator Beeps**
 - 6 beeps indicate unit is ready to bake. When the waffle maker is first plugged into electrical outlet and turned to the On position, the waffle maker will beep 6 times, indicating it has reached baking temperature (not shown).

Please note: this will only occur for the first waffle of each baking session.

 - 3 beeps indicate waffle is done.

5. **Lockdown Lid**
 - Lid will not rise as waffles bake.
6. **Folding Handle**
 - For easy storage
7. **Measuring Scoop**

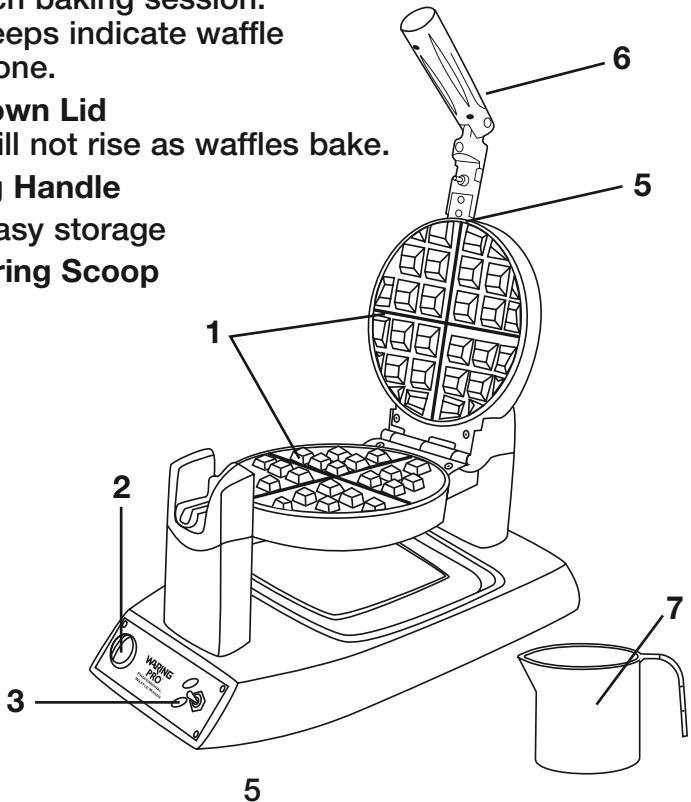

NOTE: This Waring Pro® Belgian Waffle Maker has been treated with a special nonstick coating. Before the first use, we suggest you season the waffle grids by brushing with cooking oil. Wipe with a paper towel or pastry brush.

TIPS FOR MAKING PERFECT BELGIAN WAFFLES

We recommend setting #4 when using commercial pancake/waffle mixes.

We recommend setting #4 for Belgian waffle recipes.

If you prefer crisper, darker Belgian waffles, increase the browning control.

For evenly filled waffles, pour the batter into the center of the lower grid and spread out evenly to the edges. The entire lower grid should be filled.

For best results, we recommend using $\frac{3}{4}$ cup batter or enough to fill the entire lower grid.

For added convenience while baking waffles, rest measuring scoop with handle hanging on outside of bowl and scoop on inside of bowl until the next baking cycle.

To measure flour, stir the flour first to aerate it, since it settles when it sits. Then spoon it into a measuring cup, leveling off the top with the back of a knife – do not pack down into measuring cup. These quick steps will help you avoid heavy waffles. Belgian waffles taste best when made to order, but baked Belgian waffles may be kept warm in a 200°F oven. Place in a baking pan or wrap in foil while in the oven. Waffles wrapped in foil may lose their crispness.

Baked waffles may be frozen. Allow to cool completely, and then place in plastic food storage bag. Use waxed paper to keep waffles separated. Reheat in an oven, toaster or toaster oven when ready to use.

SUGGESTED TOPPINGS

Maple syrup, fruit syrups
Warm fruit compote, fruit sauce
Fresh berries, chopped fruit, chopped nuts
Powdered sugar
Whipped cream, ice cream, sorbet
Chocolate sauce
Fruited yogurt

RECIPES

CLASSIC BELGIAN WAFFLES

Classic Belgian waffles have a crispy outside and are soft and moist on the inside. They are often served as part of a celebration – even to celebrate something as simple as a beautiful day. Try these waffles with your favorite syrup or a topping such as sliced fresh strawberries and freshly whipped cream.

Makes 10 waffles

1½ cups water
2¼ teaspoons active dry yeast (one packet)
3 cups sifted flour
¼ teaspoon salt
3 large eggs, separated + 1 egg white
⅓ cup sugar
1½ cups whole milk
8 tablespoons unsalted butter - melted and cooled
2 teaspoons vegetable oil
2 teaspoons vanilla extract

Heat ½ of the water to lukewarm, 105°-110° F. Dissolve the yeast in the water with a pinch of the sugar from the recipe; let stand 5 to 10 minutes, until the mixture begins to foam.

Put the flour and salt into a large bowl; stir to blend and reserve. Add the egg yolks, one of the egg whites, and remaining sugar to the yeast mixture; stir to blend. Add the remaining water, milk, melted butter, oil, and vanilla;

stir until the mixture is smooth. Stir the liquid mixture into the flour mixture and beat until the mixture is smooth.

Beat the egg whites until stiff peaks form. Fold the egg whites gently into the batter. Let the batter stand for 1 hour, stirring every 15 minutes.

Preheat your Waring Pro® Belgian Waffle Maker on setting #4 or preferred setting (green indicator light will be illuminated when preheated).

For best results, do not open waffle maker during cooking process. Doing so will offset the timing mechanism.

Use the measuring scoop to measure the batter and pour into the preheated waffle iron. Use a heatproof spatula to spread the batter evenly over the grids. Close lid and rotate wafflemaker 180° to the right. Bake the waffles in the waffle iron until beeper indicates that the waffle is done. Rotate waffle maker 180° to the left. Remove waffle and repeat until all batter is used. Waffles may be kept warm in a slow (200°F) oven. Place waffles arranged on a cookie sheet on a rack in the warm oven. Serve with whipped cream, fruit, jam, powdered sugar, or a warm fruit syrup.

*We recommend using setting #4 to achieve a golden brown baked Belgian waffle. Adjust the browning control if you prefer lighter or darker waffles.

Nutritional information per waffle:

*Calories 300 (40% from fat) • carb. 37g • pro. 8g
fat 13g • sat. fat 7g • chol. 94mg • sod. 104mg
calc. 61mg • fiber 1g*

GINGERBREAD BELGIAN WAFFLES

These waffles have the flavor of just baked gingerbread and are delicious served with fresh fruit or caramelized apples and pears.

Makes 6 waffles

- ½ cup warm water**
- 1 teaspoon granulated sugar**
- 2¼ teaspoons active dry yeast (1 packet)**
- 1½ cups all-purpose flour**
- 1 cup graham cracker crumbs**
- ¼ cup granulated sugar**
- ¼ teaspoon salt**
- 1 teaspoon ground ginger**
- ½ teaspoon finely chopped lemon zest**
- 2 cups warm milk (about 105°F)**
- 3 large eggs, separated**
- ½ cup unsalted butter, melted and cooled**
- 1 teaspoon vanilla extract**

Measure water into a large bowl. Add 1 teaspoon granulated sugar and yeast; stir to dissolve. Let stand 10 minutes. In a separate bowl, combine the flour, graham cracker crumbs, ¼ cup sugar, salt, ginger, and lemon zest; stir to combine. Add the milk, egg yolks, melted cooled butter, and vanilla to the yeast mixture. Stir until smooth. Add the dry ingredients and beat until smooth, using low speed of a hand mixer. Cover with waxed paper and let stand to rise in a warm, draft-free place for 30 minutes.

Beat the egg whites until stiff, but not dry. Gently fold into the batter.

Preheat your Waring Pro® Belgian Waffle Maker on setting #4 or preferred setting (green indicator light will be illuminated when preheated).

For best results, do not open waffle maker during cooking process. Doing so will offset the timing mechanism.

Use the measuring scoop to measure out batter, spreading evenly into waffle grids. Close lid and rotate 180° to the right and bake in the hot waffle maker until beeper sounds. Rotate waffle maker 180° to the left. Remove

waffle and repeat with remaining batter. Waffles may be kept warm in a slow (200°F) oven. Place waffles arranged on a cookie sheet on a rack in the warm oven. Serve with lemon curd, fruit, jam, powdered sugar, a warm fruit syrup, or whipped cream.

*We recommend using setting #4 to achieve a golden brown baked Belgian waffle. Adjust the browning control if you prefer lighter or darker waffles.

Nutritional information per waffle:

*Calories 458 (44% from fat) • carb. 23g • pro. 11g
fat 23g • sat. fat 12g • chol. 159mg • sod. 279mg
calc. 120mg • fiber 1g*

GOOD NIGHT WAFFLES

Most of the mixing for these waffles is done the night before. In the morning, just mix in the eggs, vanilla extract and a pinch of baking soda while the waffle maker is heating. Leftover batter may be covered and kept in the refrigerator for up to 3 days. Heat your waffle maker in the morning, stir the batter and have a freshly baked waffle for breakfast.

Makes 6 waffles

- ½ cup lukewarm (105°F) water**
- 1 tablespoon granulated sugar**
- 2¼ teaspoons active dry yeast (1 yeast packet)**
- 2 cups whole milk, warmed (about 105°F)**
- ½ cup unsalted butter, melted and cooled**
- 1 teaspoon salt**
- 2 cups all-purpose flour**
- 2 large eggs, lightly beaten**
- 2 teaspoons vanilla extract**
- ¼ teaspoon baking soda**

The night before, or at least 8 hours before baking, combine the warm water, granulated sugar and yeast.

Let stand 10 minutes, until foamy. Stir in the warm milk, melted butter and salt. Beat in the flour until smooth; (this may be done using a hand mixer on low speed).

Wrap bowl tightly with plastic wrap and let stand overnight (or for 8 hours) on the countertop; do not refrigerate.

When ready to bake, preheat your Waring Pro® Belgian Waffle Maker on setting #4 or preferred setting; (green indicator light will be illuminated when preheated).

For best results, do not open waffle maker during cooking process. Doing so will offset the timing mechanism.

While the waffle maker is heating, stir the eggs, vanilla extract and baking soda into the batter. Use measuring scoop to measure out batter. Pour onto waffle grids. Use a heat-proof spatula to spread the batter evenly over the grids. Close cover and rotate 180° to the right. Bake in the hot waffle maker until beeper sounds. Rotate 180° to the left. Remove waffle and repeat with remaining batter. Waffles may be kept warm in a slow (200°F) oven. Place waffles arranged on a cookie sheet on a rack in the oven. Serve with sliced fresh fruit, jam, powdered sugar, a warm fruit syrup, or whipped cream.

*We recommend using setting #4 to achieve a golden brown baked Belgian waffle. Adjust the browning control if you prefer lighter or darker waffles.

Nutritional information per waffle:

*Calories 373 (49% from fat) • carb. 38g • pro. 10g
fat 20g • sat. fat 12g • chol. 123mg • sod. 501mg
calc. 117mg • fiber 1g*

PUMPKIN NUT BELGIAN WAFFLES

These waffles taste like freshly baked pumpkin muffins and are delicious served with warm maple syrup.

Makes 6 waffles

- 1½ cups all-purpose flour
- 1 ounce finely chopped walnuts or pecans
(best if toasted first)
- 1 tablespoon cornstarch
- 1 tablespoon baking powder
- 1 teaspoon salt
- 1 teaspoon ground cinnamon
- ½ teaspoon ground ginger
- ¼ teaspoon freshly ground nutmeg
- ¾ cup pumpkin purée (canned solid pack pumpkin)
- 2 large eggs, separated
- 1 cup whole milk
- ¼ cup real maple syrup (do not use pancake syrup)
- 3 tablespoons unsalted butter, melted
- 1 teaspoon vanilla extract
- 3 large egg whites

Preheat waffle maker on setting #4.

In a large bowl, combine the flour, chopped nuts, cornstarch, baking powder, salt, cinnamon, ginger, and nutmeg. Stir to blend and reserve.

In a second bowl, combine the pumpkin purée, egg yolks, milk, maple syrup, melted butter, and vanilla extract; stir until smooth. Add the liquid ingredients to the dry ingredients and stir to blend until smooth, using a whisk.

In a clean, dry bowl, beat the egg whites until stiff peaks form. Gently fold the beaten egg whites into the batter.

Preheat your Waring Pro® Belgian Waffle Maker on setting #4 or preferred setting; (green indicator light will be illuminated when preheated).

For best results, do not open waffle maker during cooking process. Doing so will offset the timing mechanism.

Use measuring scoop to measure out batter. Pour into waffle grids. Use a heat-proof spatula to spread the

batter evenly over the grids. Close cover and rotate 180° to the right. Bake in the hot waffle maker until beeper sounds. Rotate 180° to the left. Remove waffle and repeat with remaining batter. Waffles may be kept warm in a slow (200°F) oven. Place waffles arranged on a cookie sheet on a rack in the oven. Serve with warm maple syrup, powdered sugar, or whipped cream.

*We recommend using setting #4 to achieve a golden brown baked Belgian waffle. Adjust the browning control if you prefer lighter or darker waffles.

Nutritional information per waffle:

*Calories 303 (35% from fat) • carb. 40g • pro. 10g
fat 12g • sat. fat 5g • chol. 92mg • sod. 579mg
calc. 94mg • fiber 2g*

CLEANING AND MAINTENANCE

Once you have finished baking, switch toggle to the Off position; remove plug from electrical outlet. Leave top lid open and allow grids to cool before cleaning.

Never take your Belgian waffle maker apart for cleaning. Simply brush crumbs from grooves, and absorb any excess cooking oil by wiping with a dry cloth or paper towel. You may clean the grids by wiping with a damp cloth, to prevent staining and sticking from batter or oil buildup.

Be certain that grids have cooled completely before cleaning. If batter adheres to plates, simply pour a little cooking oil onto the baked batter and let stand approximately 5 minutes, allowing batter to soften for easy removal.

To clean exterior, wipe with a soft dry cloth. Never use an abrasive cleanser or harsh pad. **NEVER IMMERSSE CORD, PLUG OR UNIT IN WATER OR OTHER LIQUID.**

©2008 Waring Products Division of Conair Corporation
150 Milford Road
East Windsor, NJ 08520

www.waringproducts.com

Printed in China

WMK300A IB
08WR119

IB-8465