



ANGLE FINISH NAILER
MODEL G3690
INSTRUCTION MANUAL



COPYRIGHT © 1995 BY GRIZZLY IMPORTS, INC.

**WARNING: NO PORTION OF THIS MANUAL MAY BE REPRODUCED IN ANY SHAPE
OR FORM WITHOUT THE WRITTEN APPROVAL OF GRIZZLY IMPORTS, INC.**

MARCH, 1995. PRINTED IN USA

DISCONTINUED MACHINE MANUAL DISCLAIMER

THE INFORMATION IN THIS MANUAL REPRESENTS THE LAST CONFIGURATION OF THE MACHINE BEFORE IT WAS DISCONTINUED. MACHINE CONFIGURATIONS MAY HAVE CHANGED AS PRODUCT IMPROVEMENTS WERE INCORPORATED. IF YOU OWN AN EARLIER VERSION OF THE MACHINE, THIS MANUAL MAY NOT EXACTLY DEPICT YOUR MACHINE. CONTACT CUSTOMER SERVICE IF YOU HAVE ANY QUESTIONS ABOUT DIFFERENCES. PREVIOUS VERSIONS ARE NOT AVAILABLE ONLINE.

WARNING

Some dust created by power sanding, sawing, grinding, drilling, and other construction activities contains chemicals known to the State of California to cause cancer, birth defects or other reproductive harm. Some examples of these chemicals are:

- Lead from lead-based paints.
- Crystalline silica from bricks, cement, and other masonry products.
- Arsenic and chromium from chemically treated lumber.

Your risk from these exposures varies, depending on how often you do this type of work. To reduce your exposure to these chemicals: work in a well ventilated area, and work with approved safety equipment, such as those dust masks that are specially designed to filter out microscopic particles.

TABLE OF CONTENTS



I. INTRODUCTION	1	E. ROUTINE USE	6
II. COMMENTARY	1	VIII. INSPECTION	8
III. SAFETY RULES	2	IX. MAINTENANCE	9
IV. UNPACKING	3	A. JAMMING	9
V. AIR	3	B. DAMAGED DRIVER	10
A. AIR PRESSURE	3	C. O-RINGS AND RE-ASSEMBLY ..	10
B. AIR QUALITY	3	D. TESTING AFTER ASSEMBLY	11
VI. PRE-USE CHECKS	4	X. TROUBLESHOOTING	11
A. CLEANING	4	XI. WARRANTY AND RETURNS	12
B. OILING	4	XII. CLOSURE	12
VII. OPERATIONS	4	XIII. TOOL DATA	13
A. LOADING FASTENERS	4	XIV. PARTS DIAGRAM	14
B. UNLOADING FASTENERS	5	XV. PARTS LIST	15
C. CONNECTING TO AIR	5	XVI. INDEX	16
D. TEST FIRING	6		

I. INTRODUCTION

The G3690 Angle Finish Nailer is designed for driving and setting clipped head finish nails in most natural and composite wood materials. It is especially suited for cabinetmaking and fastening trim moldings. The tough, lightweight construction offers dependable performance while reducing operator fatigue.

This nail gun is a part of our complete line of nail guns covering most applications. It will shoot a variety of finish nails up to 2 1/2" long. The ability to shoot longer nails makes it ideal for trim applications when applying moldings over sheet rock and fastening thicker moldings to other trim.

Grizzly is committed to offering top quality products and supporting our products through customer service and technical documentation. The manual you now have represents our latest effort to produce the best documentation possible. If you have any criticisms or comments you feel we should pay attention to in our next printing, please write us at the address below.

Manager, Technical Documentation
Grizzly Industrial, Inc.
P.O. Box 2069
Bellingham, WA 98227

We have two excellent regional service departments at your disposal, should the need arise. If you have any service questions or parts requests, please call or write us at the appropriate location listed below.

Grizzly Industrial, Inc.
1203 Lycoming Mall Circle
Muncy, PA 17756
Phone:(570) 546-9663
Fax:(800) 438-5901
E-Mail: techsupport@grizzly.com
Web Site: <http://www.grizzly.com>
Bellingham, WA 98227

To operate this, or any tool, safely and efficiently, it is essential to become as familiar with its characteristics as possible. Take as much time as necessary to become



II. COMMENTARY

acquainted with the Model G3690 Angle Finish Nailer. The time you invest before you begin to use this tool will be time well spent. Also, read all of the safety procedures. If you do not understand them, **DO NOT** operate this tool.

The specifications, drawings, and photographs illustrated in this manual represent the Model G3690 as supplied when the manual was prepared. But owing to Grizzly's policy of continuous improvement, changes to the Model G3690 may occur at any time with no obligation on the part of Grizzly. Should you receive a manual update, please insert it into the manual and keep it for reference.

The information in this manual has been obtained from sources we believe to be reliable and as up-to-date as possible. We have included some important safety measures which we believe to be essential to this machine's operation. While most safety measures are generally universal, Grizzly reminds you that each work environment is different and safety rules should be considered as *they apply to your situation*.

We also believe additional information sources are very important to better realize the full potential of this tool. Trade journals, woodworking magazines, and your local library are good places to start.

The Model G3690 was specifically designed for nailing operations. We strongly emphasize that this tool should never be modified and/or used for any application other than that for which it was designed. **Modifications or improper use of this tool will void all warranties.** If you are confused about any aspect of this tool, **DO NOT** use it until you have resolved any questions you might have.



III. SAFETY RULES FOR NAIL GUNS

1. **NEVER** leave the gun connected to an air source when inspecting or maintaining.
2. The gun must be routinely inspected for worn or damaged parts and air leaks. If the gun is faulty, it should be removed from service and labeled, "**DO NOT USE.**"
3. Make sure the safety nose is functioning properly before loading fasteners and the magazine spring is set before operating.
4. **DISCONNECT** the gun from the air source before loading fasteners.
5. **ALWAYS** point gun away from yourself and others when loading or operating.
6. **DISCONNECT** gun from the air source if gun jams or when performing other maintenance inspections.
7. **DO NOT** connect gun to the air hose until you are in position and ready to operate the gun safely.
8. **BE AWARE** of others in your work area. **NEVER** shoot the gun if others are in your line of fire.
9. **KEEP HANDS AND OTHER BODY PARTS AWAY FROM THE GUN TIP AT ALL TIMES.**
10. **NEVER** manually depress the safety nose and shoot fasteners for any reason.
11. **NEVER** leave a pressurized gun unattended, especially when children are present. Disconnect gun from the air source, remove fasteners, and put the gun out of reach.
12. **DO NOT** rest a pressurized gun against your body for any reason.
13. **DO NOT** carry gun with your finger on the trigger. Gun will fire if safety nose is accidentally depressed.
14. **DO NOT** place your free hand or feet near the gun tip to support the work. If you cannot safely support the work without placing body parts near the gun tip, do not use this gun.
15. **DO NOT** operate the gun if workpiece is between you or someone else and the gun. Reposition yourself so you and others are behind the gun.
16. **ALWAYS** wear ANSI approved personal protective equipment for your eyes and ears while operating this tool. Others near your work area must also wear eye protection.
17. All air tools exhaust compressed air. If working in an area where dust will become airborne due to exhausted air, **WEAR RESPIRATORY PROTECTION.**
18. Use only clean, dry, regulated, compressed air. **DO NOT** connect this air tool to any pressurized gas other than compressed air.
19. Air compressors must comply with ANSI B 19.3 - 1981 (U.S.), "Safety Standard for Compressors for Process Industries."
20. **DO NOT** operate at a pressure higher than 120 PSI.
21. **NEVER** use this gun for fastening aluminum, brass, metal, plastics, or any other like material.
22. Air hose must be rated as having a minimum working pressure of 150 psig or 150% of the maximum pressure produced in the line, whichever is greater. Inspect air hoses frequently.



IV. UNPACKING

Carefully remove the items packed in the carton. It may be a good idea to save the carton and packing material in case it might be needed in the future. Upon removal of all items from the package, you should have:

1. Nail Gun
2. Allen Head Wrench
3. Oil Bottle
4. Safety Goggles

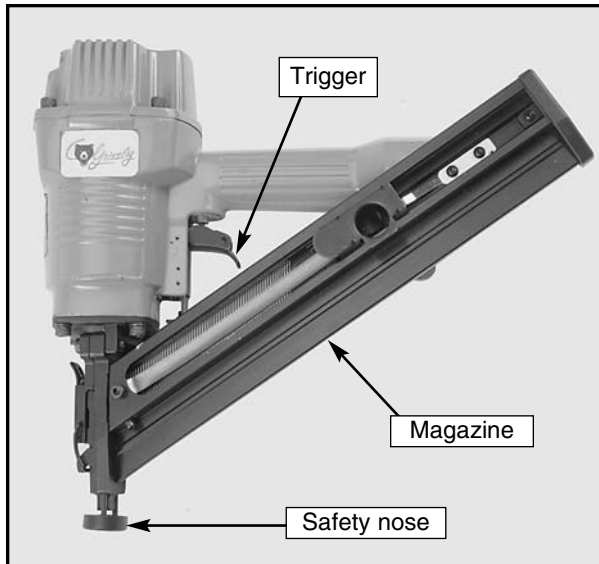

Figure 1 shows the front side of the nail gun.

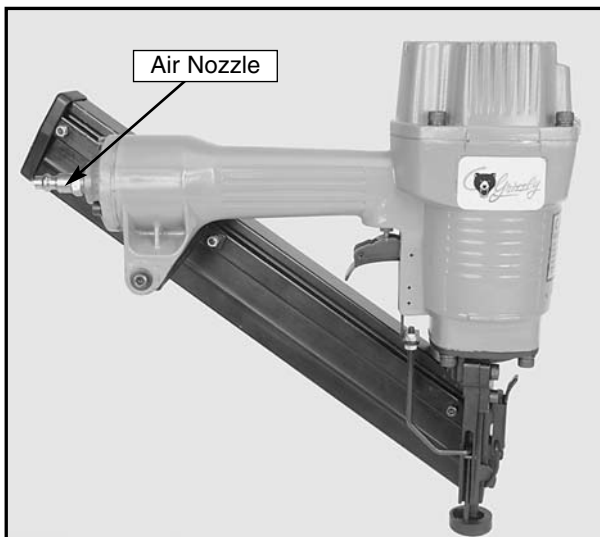

Figure 2 shows the back side of the nail gun.

V. AIR

A. AIR PRESSURE

Air pressure should be set at the minimum required to set the fastener and must not exceed 120 p.s.i. Follow all safety items above and see **Section V.B.** Consistently operating at unnecessarily high pressures will put excessive stress on internal parts which will lead to premature gun failure.

B. AIR QUALITY

This air gun must be regularly oiled and operated with treated or clean air. It is a precision tool with close internal tolerances designed for repetitious use. Wet and dirty air will negatively affect the gun's performance as well as prematurely destroy internal parts.

To ensure that the best quality air enters your nail gun:

1. Use an in-line system to automatically oil, filter, and dry compressed air. Grizzly offers an in-line regulator / filter / water-separator / lubricator (G2304). Please refer to our catalog for price and ordering information.
2. The intake air filter on your compressor must be clean and operational. Periodically clean or replace this filter. It is your primary line of defense.
3. Drain the compressor air storage tank(s) often. If conditions are humid, drain up to several times daily. Water vapor will condense and accumulate in the bottom of the storage tank(s). The internal metal parts of the nail gun will be corroded by the moisture that is passed through the air supply hose.
4. Keep air hoses as clean as possible internally. Inspect nipples and couplers for any dirt and moisture. Blow out prior to connecting the gun.



VI. PRE-USE CHECKS

A. CLEANING

Keep the gun nose as clean as possible. Dirt and debris have a tendency to work their way into the gun from the nose. Wipe off any dirt that collects on the outside of the gun before connecting it to the air supply.

B. OILING

Keep the gun oiled. Use special pneumatic tool oil to keep internal parts well lubricated. This tool oil is available through the Grizzly Catalog (G2820).

If your air supply is not pre-lubricated, you must add 2 drops of oil directly into the air nozzle at the rear of the gun each time the magazine is loaded. **NEVER USE** any oil that will corrode the rubber O-ring seals such as detergent oils or oils that are used as solvents. Avoid over-oiling.

With these points in mind, you can operate your nail gun under the best possible conditions for increased dependability and low overall cost of operation.

IMPORTANT: When you first pick up an air activated nail gun, **ALWAYS ASSUME THAT IT IS LOADED.** Inspect for any nails before connecting it to the air hose. **Do not** connect the air supply until you are in position and ready to operate the gun.



VII. OPERATIONS

A. LOADING FASTENERS

To load the gun:

1. Disconnect the air hose if connected.
2. Slide the nails into the magazine through the rear slot. **Figure 3.**
3. Pull the spring handle back behind the last nail and let it go slowly. It will press against the nails. **Figure 4.**

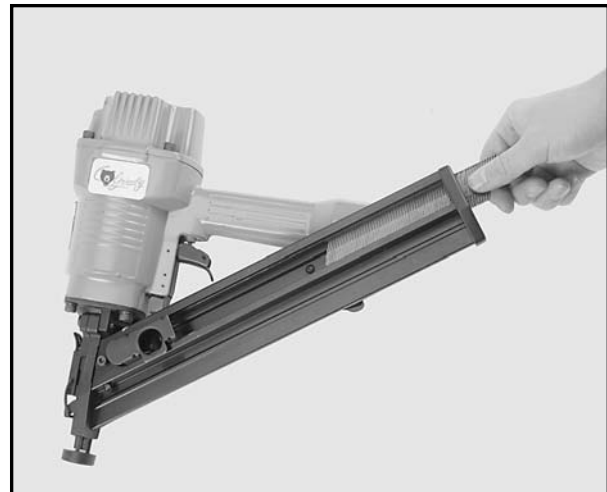

Figure 3 shows how to slide the nails in through the nail slot.



Figure 4 shows pulling back the spring handle to secure the nails and add pressure.

VII. OPERATIONS

B. UNLOADING FASTENERS

Fasteners should be removed each time you finish using the gun.

To unload the gun:

1. Disconnect the air hose if still connected.
2. Press the button inside the spring handle finger hole. **Figure 5.** Guide the spring handle to the front of the gun. **DO NOT LET THE SPRING HANDLE SNAP BACK TO ITS RESTING POSITION!**
3. Press down on the nail stop and slide the nails out through the nail slot. **Figure 6.**

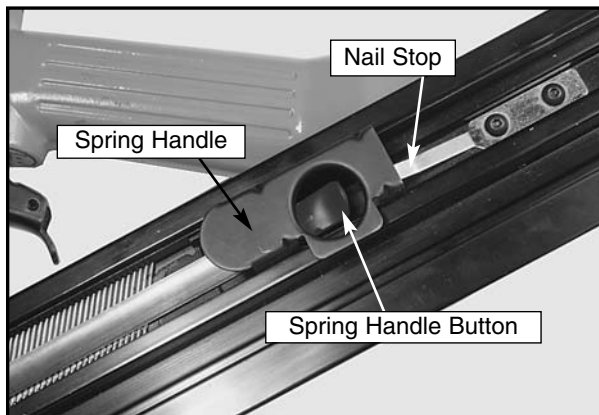

Figure 5 shows a closeup of the spring handle button. Press to release pressure.

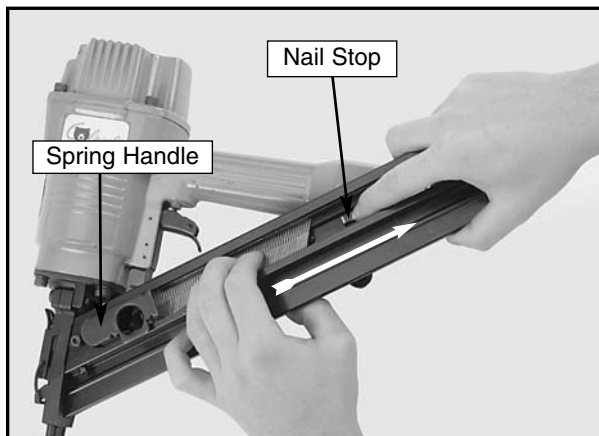

Figure 6 shows pressing down on the safety stop and sliding the nails out.

C. CONNECTING TO AIR

To connect the air hose to the air nozzle at the rear of the gun:

1. Pull back on the female hose connector sleeve.
2. Press the fitting onto the nail gun air nozzle and release the sleeve. The female fitting will lock onto the male gun fitting.
3. Listen for any air leaks. If no leaks are detected, you are ready to test fire the gun.

Always disconnect the air supply when the gun is not in use because (1) a pressurized gun is dangerous and (2) constant pressure will reduce the life of the O-rings inside the gun.

Prior to operating this nail gun, ensure that all safety procedures are read and understood. This tool is very simple to use and effectively speeds production. However, ease of use and routine production work may invite accidents. Please practice safe work habits at all times and always wear ANSI approved safety equipment.

VII. OPERATIONS

D. TEST FIRING

Whenever changing fastener size or composition of material being fastened, the gun should be tested to ensure that the air pressure is set correctly and the gun is working properly.

To test fire the gun, wear safety glasses and follow the steps below:

1. Select a sample workpiece similar in composition to the type of material you will be fastening.
2. Firmly press the safety nose down against the sample piece.
3. Pull trigger.
4. Inspect your results. If the nail is set too far into the workpiece, reduce the regulated air pressure. If the nail is not set or protrudes above the work surface, increase the air pressure. However, do not exceed the maximum air pressure recommended for the gun or the hose (120 p.s.i. for the gun).
5. Disconnect the air hose from the gun when finished.
6. Unload fasteners. See **Section VII.B.**

E. ROUTINE USE

To operate the nail gun under routine conditions, always wear safety glasses and:

1. Line up the gun nose with the area on the workpiece you intend to fasten.
2. Hold the gun straight and perpendicular to the work surface.
3. Firmly press safety nose against the workpiece so that the gun nose rests on the workpiece.
4. Pull trigger.

DO NOT DROP GUN. Repeated dropping will result in misalignment of the nose and jamming or breakage could occur. *This is a precision tool, not a hammer.*

This gun can also be continuously fired by holding down on the trigger and firmly pressing the safety nose against the workpiece each time you wish to shoot a fastener. **However, due to the inherent instability and danger involved with that practice, we strongly recommend against it.**

DO NOT FORGET TO DISCONNECT AIR SUPPLY AND UNLOAD FASTENERS WHEN FINISHED USING THE GUN.

VII. OPERATIONS

E. ROUTINE USE (CONT'D)



Figure 7 shows using the gun for a horizontal application.



Figure 8 shows using the gun for a vertical application.

Caution: If the gun nose is positioned too near the edge of the workpiece or is not held straight, there is a chance that the fastener will either split the workpiece or be deflected.

Caution: Compressed air is exhausted out of the top, front of the gun and is directed down toward the gun nose.

Do not hold the gun so that exhausted air is blown into your face or someone else's face. Exhausted air will cause any dust near the operating gun to become airborne; use a respirator if using the gun in a dusty environment.



VIII. INSPECTION

WARNING: All inspections and/or any maintenance is to be performed with the air supply disconnected from the tool.

Inspect and maintain the following items daily:

1. Check the air gun for any loose bolts or air leaks. Loose bolts should be retightened. Make sure that all lock washers are in place. Air leaks are an indication that internal seals are worn and should be replaced.
2. Make sure the safety nose and trigger are functioning properly. Repair as necessary. Do not use the gun with a broken or modified safety nose.
3. The air gun should be kept clean. Wipe off with a clean cloth daily.
4. If there is any mechanical problem with the tool, it must be taken out of service and repaired. If waiting for parts or repair, the tool must be tagged "do not use" and removed from the work area.
5. Inspect air hoses and fittings for wear and tear and replace if necessary.
6. Inspect the air compressor to ensure that it is operating properly. Follow the manufacturer's recommended maintenance schedule.
7. Inspect the automatic lubricating system if applicable and fill as required. Inspect the in-line air and water filters if applicable and change or clean as necessary.
8. Inspect the compressor regulator and/or in-line regulator to ensure that they are set correctly. Adjust accordingly.
9. Oil regularly. See **Section VI.B.**



IX. MAINTENANCE

Maintenance requirements are minimal for this nail gun. The two most common problems with any nail gun are jamming and damaged drivers. In both cases, the gun will need to be partially disassembled to make the repairs.

The third most common problem is replacing worn out O-rings. This is quite easily done, but extensive disassembly will be required. We suggest consulting with the Grizzly service staff for special instructions if needed. Grizzly has replacement parts and a special O-ring rebuilding kit available for this tool. Please call or write the appropriate service location listed on page one of this manual for prices and ordering information.

Again, if repairs become necessary that are beyond the scope of this manual, do not hesitate to call or write the appropriate service location.



Figure 9 shows the safety clip that keeps the nose of the gun closed.

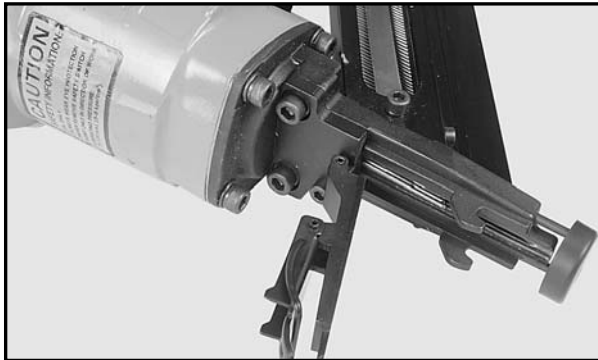

Figure 10 shows the nose open and the jammed nail exposed. Remove with needle nose pliers.

A. JAMMING

To repair a jam:

1. Disconnect gun from the air supply.
2. Remove any fasteners remaining in the gun.
3. Open the nose by unlocking the safety clip.
4. Using needle nose pliers, remove any bent fasteners lodged in the gun nose.
5. Close the nose and re-lock the safety clip.
6. Re-load fasteners and connect nail gun to the air supply.
7. Make sure the safety nose is functioning correctly and that it slides freely in its guide. Test fire into a sample piece after following all operational and safety procedures discussed earlier.

If jamming persists, make sure you are using fasteners within the size range of this gun. If jamming is due to worn or broken parts, repair or replace them before placing the gun back into service. For example, a worn or damaged driver may cause jamming. If the driver tip is worn, you may be able to recondition the tip by filing it square again. In any event, you must remove the damaged driver from the gun. See **Section IX.B.**

IX. MAINTENANCE

B. DAMAGED DRIVER

To remove the driver:

1. Disconnect gun from the air supply and remove any fasteners from the magazine.
2. Loosen the 4 cap screws securing the gun cap to the gun body sequentially.
3. Remove the four cap screws and the gun cap and place them to one side.
4. With your fingers, reach into the air cylinder, grasp the main piston, and pull out the driver.
5. Inspect driver condition and repair or replace as necessary. Replacement drivers are sold pre-attached to the main piston and are referred to as the “complete driver unit”.

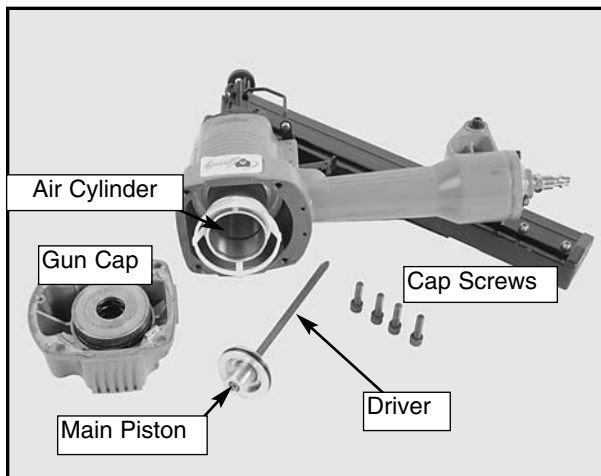

Figure 11 shows the gun partially disassembled to repair or replace the driver.

NOTE: Before putting the gun back together, read through **Section IX.C.**

C. O-RINGS AND RE-ASSEMBLY

Since the gun is disassembled, inspect the condition of the visible O-rings. If the O-rings show signs of wear and tear, they should be replaced. Inspect the surfaces where the O-rings seal for any possible rough spots which will erode the new O-rings. When replacing the O-rings, make sure that there is no dirt or grit in the groove where the O-rings seat. Do not stretch the O-rings or nick them on any sharp edges or burrs. If cleaning parts with a solvent, do not use a solvent that may deteriorate the O-rings.

To re-assemble the gun:

1. Before replacing O-rings, lubricate them with a light grease that is non corrosive to rubber.
2. **IMPORTANT:** Carefully position the driver tip into the plastic driver insert from the top of the nail gun. You may have to wiggle the driver so the main piston seats into the cylinder. The driver has a T-shaped cross section and will only fit one way. If the driver is not seating, do not force it. Remove the driver unit, rotate 180°, and try to reinstall it.
3. Replace the cap on top of the gun. Tighten the cap screws sequentially. **If the cap screws are not tightened evenly, the cap will not seat correctly, air will leak, and the gun will not function. Ensure that the washers are installed under the cap screw heads.**
4. Re-check all bolts to make sure they are tight and test the gun to ensure that it works properly. See the following paragraph.

IX. MAINTENANCE

D. TESTING AFTER ASSEMBLY

To initially test the gun after a repair procedure:

1. Put on your safety glasses, reduce the regulated air pressure to 30 PSI. **Do not** put any fasteners into the magazine. Connect the air hose.

NOTE: It is important to reduce the initial test pressure so that damage to the gun does not occur when firing without any fasteners in the magazine.

2. Check for any leaking air. You will hear it hissing or feel it rushing through the spaces.
3. If everything sounds normal, press the safety nose down on a piece of wood and pull the trigger a couple of times. Air should be exhausted normally each time.
4. Disconnect the air hose. Adjust the regulated air pressure back up to the minimum required to set your fasteners. Load the magazine with recommended fasteners.
5. Re-connect the nail gun to the air supply.
6. Press the safety nose on a suitable test material and pull the trigger. If the gun is still not working properly, re-check your repair procedure or call the appropriate service location for advice.

See **Section VII.D and VII.E.** for more information about testing and routine use.



X. TROUBLESHOOTING

This section covers some other potential problems and possible causes. If you have taken the gun apart before, as in the above section, you will realize that most problems can be repaired on the job site with a few basic parts. If you are heavily dependent upon this tool for production work, it makes good sense to have an O-ring repair kit and a complete driver unit on hand just in case a problem does develop.

The following list describes some potential problems and solutions.

1. **LEAKS: A leak can usually be fixed by simply loosening and retightening the cap screws on the gun cap symmetrically or providing more lubricant to the O-rings.**
2. If the driver does not return to its starting position, then the main piston O-ring may be worn or broken.
3. If air constantly leaks at the exhaust port, then the head valve piston O-ring may be worn or broken.
4. If air constantly leaks at the trigger, then the trigger system O-rings may be worn or broken.
5. If the gun misfires or over-drives the fastener into the workpiece without manually changing the air pressure, then the bumper may be worn or broken.
6. If the wrong type of oil has been used for lubrication, O-rings may swell and dislodge from their grooves. This could cause leaks anywhere in the gun.

Again, if you have a problem and would like assistance, please call the appropriate service department. They will be glad to assist you.



XI. WARRANTY AND RETURNS

LIMITED WARRANTY

Grizzly Imports, Inc. warrants every product it sells for a period of **1 year** to the original purchaser from the date of purchase. This warranty does not apply to defects due directly or indirectly to misuse, abuse, negligence, accidents, repairs or alterations or lack of maintenance. This is Grizzly's sole written warranty and any and all warranties that may be implied by law, including any merchantability or fitness, for any particular purpose, are hereby limited to the duration of this written warranty. We do not warrant or represent that the merchandise complies with the provisions of any law or acts unless the manufacturer so warrants. In no event shall Grizzly's liability under this warranty exceed the purchase price paid for the product and any legal actions brought against Grizzly shall be tried in the State of Washington, County of Whatcom.

We shall in no event be liable for death, injuries to persons or property or for incidental, contingent, special, or consequential damages arising from the use of our products.

To take advantage of this warranty, contact us by mail or phone and give us all the details. We will then issue you a "Return Number" which must be clearly posted on the outside as well as the inside of the carton. We will not accept any item back without this number. Proof of purchase must accompany the merchandise.

The manufacturers reserve the right to change specifications at any time because they constantly strive to achieve better quality equipment. We make every effort to ensure that our products meet high quality and durability standards and we hope you never need to use this warranty.

XII. CLOSURE

The following pages contain general machine specifications, a parts diagram and list, and index for your Model G3690 Nail Gun.

If you need parts or help in assembling your machine, or if you need operational information, we encourage you to call the appropriate Regional Service Department. Our highly trained service technicians will be glad to help you.

If you have any comments or concerns dealing specifically with this manual, please write to our Bellingham, Washington location using the address listed in the **Introduction**.





XIII. TOOL DATA

GRIZZLY MODEL G3690 ANGLE FINISH NAILER

Operating Air Pressure:

Softwood:	80 to 100 PSI
Maximum Air Pressure	120 PSI
Hardwood:	90 to 120 PSI
Maximum Air Pressure	120 PSI

Nail Length: 1-1/2" to 2-1/2" Clipped Head Finish Nails

Nail Gauge: 14 or 15

Magazine Capacity: 100 @ 15 Ga. or 90 @ 14 Ga.

Construction: Cast Aluminum and Hardened Steel

Coupling System: 1/4" NPT

Recommended Lubricating Oil: Pneumatic Tool Oil

Gun Weight: 5.95 lbs.

Parts and Accessories:

A rebuilding kit is available from Grizzly and includes all O-rings. The rebuilding kit and other parts can be individually ordered through the appropriate service department.

Grizzly also carries an air hose, an in-line regulator/filter/water-separator/lubricator, quick connect couplers, and a complete line of fasteners for this gun. Please refer to a current Grizzly catalog for price and ordering information.

Specifications, while deemed accurate, are not guaranteed.

XIV. PARTS DIAGRAM

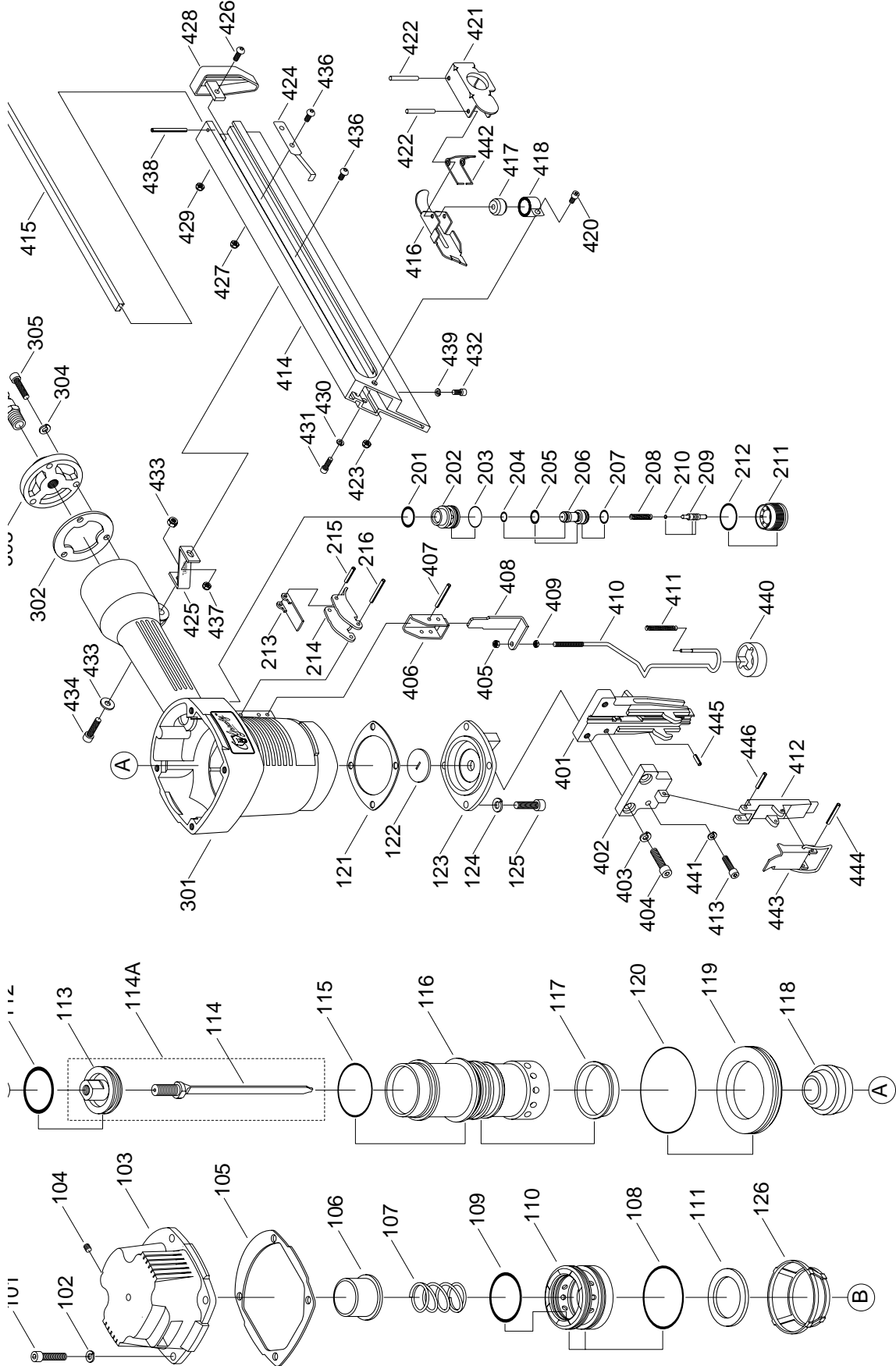



XV. PARTS LIST

REF#	PART#	DESCRIPTION	REF#	PART#	DESCRIPTION
101	PSB06M	CAP SCREW M6 - 1.0 x 25	305	PSB15M	CAP SCREW M5 - 0.8 x 20
102	PLW03M	LOCK WASHER 6mm	306	G2308	QUICK CONNECT 1/4" NPT
103	P3690101	CAP	401	P3690401	DRIVER GUIDE
104	PSS07M	SETScrew M5 - 0.8 x 5	402	P3690402	DRIVER GUIDE COVER B
105	P3690105	GASKET	403	PLW03M	LOCK WASHER 6mm
106	P3690106	SEAL	404	PSB06M	CAP SCREW M6 - 1.0 x 25
107	P3690107	SPRING	405	PLN01M	LOCK NUT M4 - 0.7
108	P3690108	O-RING	406	P3690406	SAFETY GUIDE
109	P3690109	O-RING	407	PRP16M	ROLL PIN 3 x 25
110	P3690110	VALVE PISTON	408	P3690408	SAFETY DRIVER
111	P3690111	COLLAR	409	PN04M	HEX NUT M4 - 0.7
112	P3690112	O-RING	410	P3690410	SAFETY
113	P3690113	MAIN PISTON	411	P3690411	SPRING
114	P3690114	DRIVER	412	P3690412	DRIVER GUIDE COVER A
114A	P3690114A	COMPLETE DRIVER UNIT	413	PSB33M	CAP SCREW M5 - 0.8 x 12
115	P3690115	O-RING	414	P3690414	MAGAZINE
116	P3690116	CYLINDER	415	P3690415	STEEL CHANNEL
117	P3690117	CYLINDER RING	416	P3690416	PUSHER
118	P3690118	BUMPER	417	P3690417	NYLON ROLLER
119	P3690119	CYLINDER SPACER	418	P3690418	SPRING
120	P3690120	O-RING	420	PSB03M	CAP SCREW M5 - 0.8 x 8
121	P3690121	GASKET	421	P3690421	PIN EJECT EXTERNAL HANDLE
122	P3690122	DRIVER GUIDE	422	P3690422	STEEL PIN
123	P3690123	BASE	423	PLN02M	LOCK NUT M5 - 0.8
124	PLW03M	LOCK WASHER 6mm	424	P3690424	STOP PLATE
125	PSB02M	CAP SCREW M6 - 1.0 x 20	425	P3690425	MOUNTING BRACKET
126	P3690126	CYLINDER PRESS RING	426	P3690426	BUTTON HD SCRW M4 - 0.7 x 10
201	P3690201	O-RING	427	PLN01M	LOCK NUT M4 - 0.7
202	P3690202	VALVE	428	P3690428	PROTECTING COVER
203	P3690203	O-RING	429	PLN01M	LOCK NUT M4 - 0.7
204	P3690204	O-RING	430	PLW02M	LOCK WASHER 4mm
205	P3690205	O-RING	431	PSB18M	CAP SCREW M4 - 0.7 x 8
206	P3690206	VALVE PLUNGER	432	PSB23M	CAP SCREW M4 - 0.7 x 12
207	P3690207	O-RING	433	PW02M	FLAT WASHER 5mm
208	P3690208	SPRING	434	PSB53M	CAP SCREW M5 - 0.8 x 18
209	P3690209	PLUNGER	435	PLN01M	LOCK NUT M5 - 0.8
210	P3690210	O-RING	436	P3690436	BUTTON HD SCRW M4 - 0.7 x 8
211	P3690211	PLUNGER CAP	437	PLN02M	LOCK NUT M4 - 0.7
212	P3690212	O-RING	438	PRP42M	ROLL PIN 3 x 34
213	P3690213	SECONDARY TRIGGER	439	PLW02M	LOCK WASHER 4mm
214	P3690214	TRIGGER	440	P3690440	RUBBER FOOT
215	PRP02M	ROLL PIN 3 x 16	441	PLW01M	LOCK WASHER 5mm
216	PRP16M	ROLL PIN 3 x 25	442	P3690442	SPRING
301	P3690301	GUN BODY	443	P3690443	LOCK HANDLE UNIT
302	P3690302	GASKET	444	PRP43M	ROLL PIN 3 x 22
303	P3690303	END CAP	445	PRP44M	ROLL PIN 3 x 10
304	PLW01M	LOCK WASHER 5mm	446	PRP02M	ROLL PIN 3 x 16

XVI. INDEX



A	
Addresses	1
Air Pressure	3
Air Quality	3
C	
Clean Air Hoses	3
Cleaning	4
Closure	12
Commentary	1
Connecting to Air	5
D	
Damaged Driver	10
F	
Fax Numbers	1
H	
Horizontal Nailing	7
Humid Air	3
I	
Inspection	8
Introduction	1
Items List	3
J	
Jamming	9
L	
Loading Fasteners	4
M	
Maintenance	9-11
O	
Oiling	4
Operations	4-7
O-rings	4
O-rings and Re-assembly	10
P	
Parts Diagram	14
Parts List	14
Phone Numbers	1
Pneumatic Tool Oil	4
Pre-Use Checks	4
R	
Removing the Driver	10
Routine Use	6-7

S	
Safety Rules for Nail Guns	2
Spring Handle	5
T	
Test Firing	6
Testing after Assembly	11
Tool Data	13
Troubleshooting	11
U	
Unloading Fasteners	5
Unpacking	3
V	
Vertical Nailing	7
W	
Warranty and Returns	12

FIGURES

Figure 1 shows the front side of the nail gun.	3
Figure 2 shows the back side of the nail gun.	3
Figure 3 shows how to slide the nails in through the nail slot.	4
Figure 4 shows pulling back the spring handle to secure the nails and add pressure. ...	4
Figure 5 shows a closeup of the spring handle button. Press to release pressure.	5
Figure 6 shows pressing down on the safety stop and sliding the nails out.	5
Figure 7 shows using the gun for a horizontal application.	6
Figure 8 shows using the gun for a vertical application.	7
Figure 9 shows the safety clip that keeps the nose of the gun closed.	9
Figure 10 shows the nose open and the jammed nail exposed.	9
Figure 11 shows the gun partially disassembled to repair or replace the driver.	10