

Smart choice for power

xantrex



STXR1500
STXR2500

Installation and Operation Guide

Xantrex
Sun Tie XR

www.xantrex.com

Sun Tie XR

Installation and Operation Guide

About Xantrex

Xantrex Technology Inc. is a world-leading supplier of advanced power electronics and controls with products from 50 watt mobile units to one MW utility-scale systems for wind, solar, batteries, fuel cells, microturbines, and backup power applications in both grid-connected and stand-alone systems. Xantrex products include inverters, battery chargers, programmable power supplies, and variable speed drives that convert, supply, control, clean, and distribute electrical power.

Trademarks

Xantrex is a registered trademark of Xantrex International.

Other trademarks, registered trademarks, and product names are the property of their respective owners and are used herein for identification purposes only.

Notice of Copyright

Sun Tie XR Installation and Operation Guide © February 2003 Xantrex International. All rights reserved.

Disclaimer

UNLESS SPECIFICALLY AGREED TO IN WRITING, XANTREX TECHNOLOGY INC. ("XANTREX")

(a) MAKES NO WARRANTY AS TO THE ACCURACY, SUFFICIENCY OR SUITABILITY OF ANY TECHNICAL OR OTHER INFORMATION PROVIDED IN ITS MANUALS OR OTHER DOCUMENTATION.

(b) ASSUMES NO RESPONSIBILITY OR LIABILITY FOR LOSS OR DAMAGE, WHETHER DIRECT, INDIRECT, CONSEQUENTIAL OR INCIDENTAL, WHICH MIGHT ARISE OUT OF THE USE OF SUCH INFORMATION. THE USE OF ANY SUCH INFORMATION WILL BE ENTIRELY AT THE USER'S RISK.

Date and Revision

February 2003, Revision 1

Part Number

975-0053-01-01

Contact Information

Telephone: 360.435.8826

Fax: 360.925.5143

Email: CustomerService@xantrex.com

Web: www.xantrex.com

About This Guide

Purpose

The *Sun Tie XR Installation and Operation Guide* contains information for a qualified installer and authorized service person to install, operate and troubleshoot the Xantrex Sun Tie XR.

Scope

The guide provides safety guidelines, installation, operation, troubleshooting, and warranty information for the Sun Tie XR.

The guide does not provide detailed information about solar (photovoltaic or “PV”) arrays or requirements for connecting to the utility power grid. You will need to consult the PV array manufacturer’s guide and your local electrical utility for this information.

Organization

This guide is organized into four chapters and two appendixes:

[Chapter 1, “Introduction”](#), outlines the main performance and safety features of the Sun Tie XR. Reading this chapter will give you a clear understanding of the inverter’s capabilities.

[Chapter 2, “Installation”](#), provides information about planning for and performing a Sun Tie XR installation.

[Chapter 3, “Operation”](#), provides procedures for starting up the inverter and operating the unit. It explains how to read the front panel display to monitor the Sun Tie XR’s operation.

[Chapter 4, “Troubleshooting”](#), for authorized service personnel only, explains how to identify and solve problems that can occur with the Sun Tie XR.

[Appendix A, “Specifications”](#), provides the electrical, mechanical and physical specifications of the Sun Tie XR.

[Appendix B, “Warranty and Product Information”](#), contains the product’s warranty. The appendix also explains how to return a product for service, and to prepare for a call to Xantrex Customer Service.

Conventions Used

To reduce the risk of electrical shock and to ensure the safe installation and operation of this product, the following safety symbols have been placed throughout this manual to indicate dangerous conditions and important safety instructions.



WARNING

Warnings identify conditions that could result in personal injury or loss of life.



CAUTION

Cautions identify conditions or practices that could result in damage to the Sun Tie XR or to other equipment.

Note: Notes describe additional information which may add to your understanding of how to install or use the Sun Tie XR.

Related Information

You can find more information about Xantrex Technology Inc. and its products and services at www.xantrex.com

Contents

1 Introduction

About the Sun Tie XR-	1-2
Standard Features	1-3
Accessories	1-3

2 Installation

Installation Planning-	2-2
Overview	2-2
Tools required	2-2
Hardware and materials required	2-2
Locating the Sun Tie XR	2-3
Routing the wires	2-3
Planning AC Connections	2-4
Recommended wire sizes	2-4
AC circuit breaker requirements	2-5
Planning DC Connections	2-5
Grounding Requirements	2-6
PV Array Requirements	2-7
Installation	2-9
Overview	2-9
Mounting	2-9
Connecting DC Wiring	2-15
Connecting AC Wiring	2-16
Grounding the System	2-18
Connecting Inverters in Parallel	2-21
Installing the Optional Remote Monitor	2-22

3 Operation

Startup Procedure-	3-2
Required Equipment	3-2
Checking the PV Array DC Voltage	3-2
Checking the AC Utility Voltage	3-3
Starting up the Sun Tie XR	3-4
Monitoring the Front Panel Display	3-5
Reading the Front Panel Display	3-6
Status Indicator Lights	3-7
Reassembling the Sun Tie XR	3-8

Contents

Factors Affecting Sun Tie XR Performance- - - - -	3-10
PV Array Factors - - - - -	3-10
Other Factors - - - - -	3-11
4 Troubleshooting	
Troubleshooting the Sun Tie XR - - - - -	4-2
Viewing the Status LEDs - - - - -	4-2
Troubleshooting Reference Table - - - - -	4-5
A Specifications	
Electrical Specifications- - - - -	A-2
Mechanical Specifications - - - - -	A-3
Standard Features and Options - - - - -	A-4
Efficiency Curve- - - - -	A-5
Temperature Derating Curve- - - - -	A-6
B Warranty and Product Information	
Limited Warranty - - - - -	B-2
Return Material Authorization Policy - - - - -	B-5
Return Procedure - - - - -	B-5
Information About Your System - - - - -	B-6

Important Safety Instructions



WARNING: SAVE THESE INSTRUCTIONS

This manual contains important safety instructions that should be followed during the installation and maintenance of this product. Specific safety instructions for installation, operation, and troubleshooting are in their respective sections. Read and keep this manual for future reference.



DANGER: SHOCK HAZARD

Do not remove the upper cover. Removing the upper cover should be performed only by authorized service personnel. If you suspect your unit is not functioning correctly, call Xantrex.

For safe installation and operation:

- All electrical work must be done in accordance with local and national electrical codes.
- Before installing or using this device, read all instructions and cautionary markings located in the manual, on the Sun Tie XR and on the PV array.

Important Safety Instructions

- Do not expose this unit to rain, snow or liquids of any type without the Rain Shield installed. The Rain Shield does not, however, make the Sun Tie XR waterproof.
- To reduce the chance of short circuits when installing or working with the inverter or the PV array, use insulated tools.
- Remove all jewelry such as rings, bracelets, wristwatches and necklaces prior to installing this system. This will greatly reduce the chance of accidental exposure to live circuits.
- The Sun Tie XR contains more than one live circuit (the PV array and the AC line). Power may be present at more than one source even when the circuit breakers are off.
- This product contains no user-serviceable parts. Return the unit to Xantrex for maintenance.
- Wiring to the utility should only be done after receiving prior approval from the utility company and performed only by a qualified electrician.
- Completely cover the surface of all PV arrays with an opaque (dark) material **before** wiring them. PV arrays produce electrical energy when exposed to light and could create a hazardous condition.

1

Introduction

Chapter 1, “[Introduction](#)”, describes the standard features and accessories for the Sun Tie XR.

About the Sun Tie XR

The Xantrex Sun Tie XR grid-connect solar inverter is designed to convert a home or business into a “green” power generating station. The Sun Tie XR converts solar electric (photovoltaic, or PV) power into utility-grade electricity that can be used by the home or sold to the power company. Installing the Sun Tie XR consists of mounting it to the wall and connecting a DC source (a PV array) and the AC output to the utility. See [Figure 1-1](#) for a simple diagram of a typical installation. In order to operate, the Sun Tie XR must have grid power available and connected. It will not provide backup power.

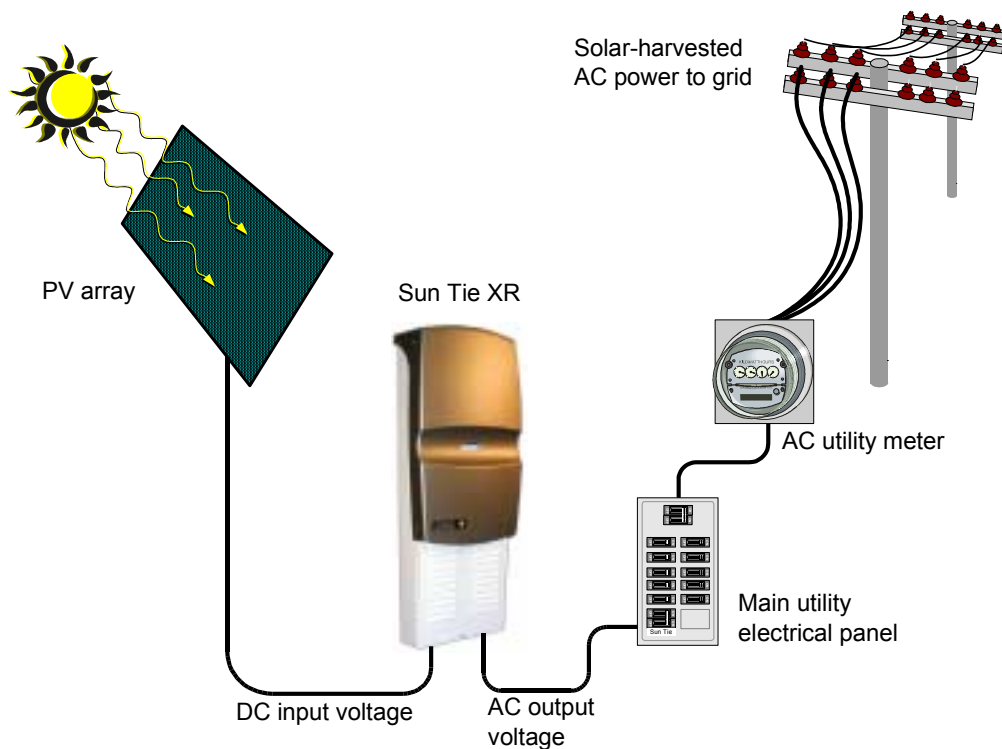

Figure 1-1 Basic System Overview

Note: [Figure 1-1](#) is a one-line drawing intended as a system overview only. System grounding and other electrical details are not included.

Standard Features

All-in-one design	All necessary DC input and AC output connections, disconnects and circuit breakers are housed within the Sun Tie XR's easily installed, compact enclosure. A built-in LCD display panel provides easy-to-read system status and daily cumulative energy production information. Two status LEDs inside the unit also provide operating and troubleshooting information.
Uses most types of PV technology	The Sun Tie XR is designed to take advantage of most types of solar electric technologies. The inverter allows up to 120 VDC open circuit PV modules to be used, so it will work with both crystalline and thin film PV modules.
Sun Sweep™ Maximum Power Point Tracking (MPPT)	Sun Sweep™ is Xantrex's proprietary Maximum Power Point Tracking technology that allows the Sun Tie XR to harvest the maximum amount of energy from your solar array. No matter what PV system you choose—single crystalline, polycrystalline or thin film—SunSweep™ learns your array's specific characteristics, maximizing its output all day, all season, year after year.
High efficiency	The high-frequency, solid-state design of the Sun Tie XR inverter is extremely efficient. Above 500 watts, the inversion process is 90% efficient (or greater) with a peak efficiency of 91%.
Expandable	Sun Tie XR inverters may be connected in a parallel configuration for increasing net metering capacity. The modular expandability of the Sun Tie XR Series allows for system growth.
Meets standards and requirements	The Sun Tie XR has complete on-board islanding protection and meets U.S. and Canadian safety operating standards and code requirements.

Accessories

- STRM—Sun Tie XR Remote Monitor, for remote display of system status, energy production, troubleshooting log, and resetting Wh.
- STRS—Sun Tie XR Rain Shield, required for outdoor installation.

2

Installation

Chapter 2, “Installation” provides information about planning for and installing the Sun Tie XR. It contains information to help you plan wire routes, AC and DC connections, and find a suitable location for installation. It also discusses requirements for grounding the Sun Tie XR and your PV array.

This chapter then provides procedures to install the Sun Tie XR, including mounting, making DC and AC connections, and grounding the inverter and the PV array.

Installation Planning

Overview

Before you begin to install the Sun Tie XR you need to consider the following:

- tools required
- hardware and materials required
- mounting location
- routes for AC and DC wiring
- AC and DC connection wire size requirements
- grounding requirements
- PV array requirements

Tools required

- | | |
|---|--|
| <input type="checkbox"/> Phillips screwdrivers | <input type="checkbox"/> level |
| <input type="checkbox"/> slot-head screwdrivers | <input type="checkbox"/> wire strippers |
| <input type="checkbox"/> open-end wrenches | <input type="checkbox"/> torque wrench |
| <input type="checkbox"/> socket wrench and fittings | <input type="checkbox"/> electrical tape |
| <input type="checkbox"/> 3/32" hex bit | <input type="checkbox"/> pencil |
| <input type="checkbox"/> multimeter | <input type="checkbox"/> utility knife |
| <input type="checkbox"/> frequency counter (optional) | |

Hardware and materials required

- wood screws and washers (supplied)
- metal conduit and appropriate fittings
- anchors for screws (material dependent)

Locating the Sun Tie XR

The Sun Tie XR should be installed in locations that meet the following requirements:

Vertical	The UL listing for the Sun Tie XR requires it to be mounted vertically.
Dry	When the Sun Tie is mounted outdoors, attach the optional Rain Shield (STRS) to prevent water entering the unit.
Temperature	The unit meets specifications from 32 to 113 °F (0 to 45 °C) but will operate within the temperature extremes of most climates—from -38 to 113 °F (-39 to 45 °C). At extreme cold temperatures the LCD display may not function normally and it is recommended that an indoor-mounted Remote Monitor be used. At temperatures above 45 °C, the unit begins derating power. See “Temperature Derating Curve” on page A-6.
Ground clearance	The Sun Tie requires at least 36 inches (100 cm) of clearance between the bottom of the unit and the ground.
Dust free	Dust can be drawn inside and accumulate within the unit, interfering with wiring connections and ventilation.



WARNING: SHOCK HAZARD

Do not install the Sun Tie XR unit outdoors without the Rain Shield. Water entering the unit could cause a dangerous condition and cause the unit to fail. Failure due to improper installation will void the warranty.

Routing the wires

Typical configurations

Determine all wire routes to and from the Sun Tie XR. Typical routing configurations include:

- AC wiring from the Sun Tie XR to the main service panel
- DC input wiring from the PV array to the Sun Tie XR
- DC ground from the PV array to an external ground rod

Installation

	All wiring and installation methods should conform to applicable electrical and building codes.
Conduit holes	Pre-plan the wire and conduit runs. Knockouts for conduit holes are located on the bottom of the unit. See Figure 2-9 .
Acceptable wire sizes	The DC terminal blocks in the Sun Tie XR accept up to a #6 AWG wire. The AC circuit disconnects accept cable sizes up to #6 AWG. For maximum safety, run AC and DC wires/cables in separate conduits.



WARNING: SHOCK HAZARD

Check for existing electrical or plumbing prior to drilling holes in the walls.

Planning AC Connections

AC connections include all the wires and connectors between the Sun Tie XR AC output breakers and the main utility electrical panel. [Figure 2-14](#) and [Figure 2-15](#) show simplified diagrams of the entire installation.

Recommended wire sizes

The AC output breakers accept wire sizes from #6–14 AWG. Refer to [Table 2-1](#) for minimum recommended wire size. The values in [Table 2-1](#) are the minimum recommended wire sizes in conduit. Installing a large number of wires in conduit or enclosed locations may require larger wire sizes. Consult your local/national electrical code for more information.

Table 2-1 Recommended minimum AC wire sizes

Inverter model	AC amps output per leg	NEC amps per leg (amps x 125%)	Minimum wire size for specified distance		
			0-50 ft one way	50-100 ft one way	100-200 ft one way
STXR1500	6.3	7.9	14 AWG	10 AWG	8 AWG
STXR2500	10.4	13.0	12 AWG	8 AWG	6 AWG

Note: The six-circuit combiner board is rated for 100 amps (I_{mp}) of maximum real current. Although the 20 amp fuses will theoretically allow 120 amps to be applied, always design for a maximum of 100 amps maximum current. With appropriate fuse deratings, per NEC code, the maximum allowed current is 16 amps for any of the six circuits.

AC circuit breaker requirements

The main service panel must dedicate a 15 amp minimum, double pole breaker (120/240 volts AC) to operate the Sun Tie XR.

Planning DC Connections

DC connections include all the wires and connectors between your PV array and the Sun Tie XR's combiner board. [Figure 2-1](#) and [Figure 2-2](#) show the combiner board and connection points. [Figure 2-14](#) and [Figure 2-15](#) show simplified diagrams of the entire installation.

Wire Sizes	The DC connections are made on the combiner board inside the Sun Tie XR. The combiner board accepts wire sizes from #6–14 AWG. Refer to Table 2-2 for minimum recommended wire sizes.
Exceptions	The values in Table 2-2 are the minimum recommended wire sizes. Installing a large number of wires in conduit or enclosed locations may require larger wire sizes. Consult your local or national electrical code for more information.
NEC Restrictions	The National Electrical Code (NEC) places restrictions on minimum DC wire bending radius. A #6 AWG wire is the largest that may be used on the Sun Tie XR when connecting to the individual fused circuits of the combiner board.

Table 2-2 Recommended minimum DC wire sizes

DC amps (I_{mp}) (from PV array)	NEC amps (amps x 156%)	Minimum wire size for specified distance		
		0-25 ft one way	25-50 ft one way	50-100 ft one way
1.0	1.6	14 AWG	14 AWG	14 AWG
3.0	4.7	14 AWG	12 AWG	10 AWG
5.0	7.8	12 AWG	10 AWG	6 AWG
7.0	10.9	12 AWG	8 AWG	6 AWG
9.0	14.0	10 AWG	8 AWG	Not Recommended
11.0	17.2	10 AWG	6 AWG	Not Recommended

Note: For an installation requiring a two-wire run (positive and negative), the PV array wires can bypass the individual fused combiner board terminals and connect directly to the input terminals (through an externally mounted DC fused combiner box) by using the positive and negative bypass terminals on the combiner board. Refer to [Figure 2-2](#) and [Table 2-2](#) for connection and wire sizes.

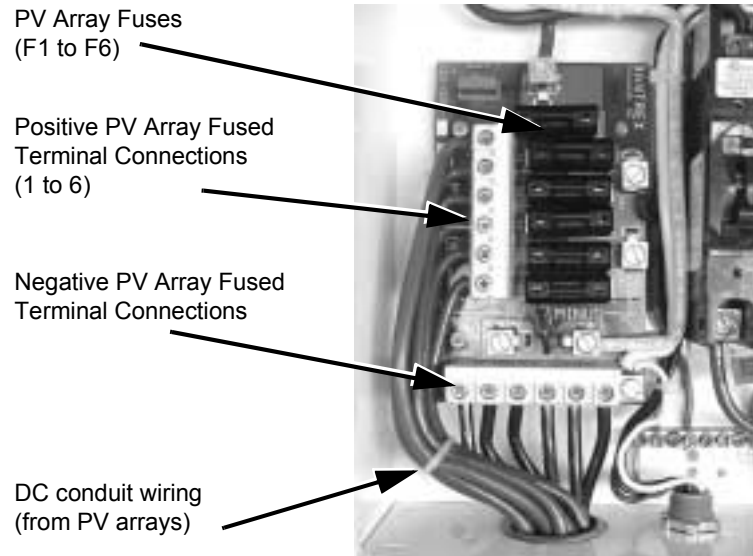

Figure 2-1 Combiner board with PV array wiring to individual terminal connections

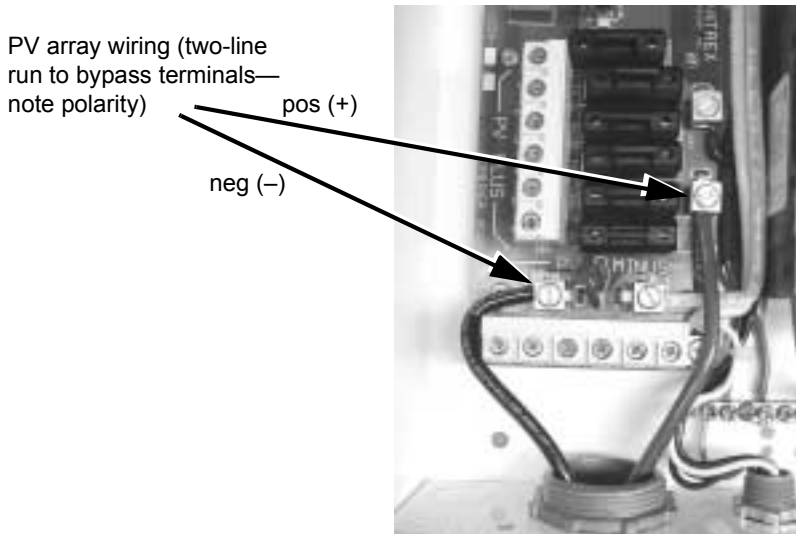

Figure 2-2 Combiner board with PV array wiring to bypass terminals

Grounding Requirements

AC grounding

The Sun Tie XR must be connected to a grounded, permanent wiring system.

DC grounding

The negative PV conductor must be bonded to the grounding system at only one point in the system. See [Figure 2-3](#) for the location of the Sun Tie XR ground bar. The size for the conductor is usually based on the size of the largest conductor in the DC system. Negative/ground bonding is accomplished by factory-wired PVGFP breakers.

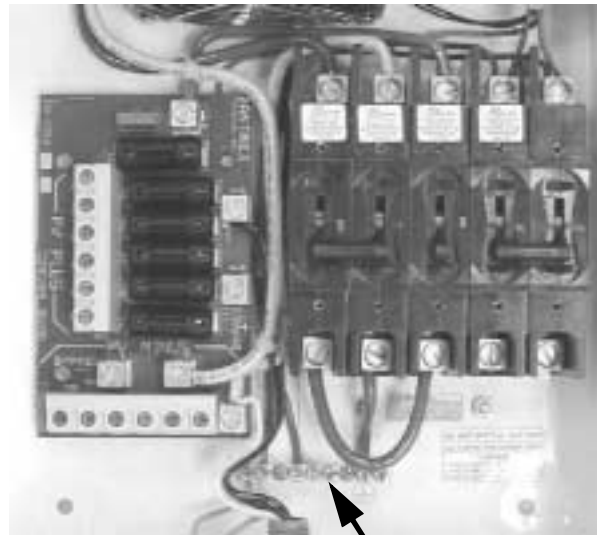

Ground bar
(connect to solid earth ground)

Figure 2-3 Ground bar location

PV Array Requirements

MPPT operational window

The Sun Tie XR is optimized to work with 4-each, 12 volt nominal crystalline PV modules in series (48 VDC nominal), or various combinations of amorphous, thin film PV modules. Ensure the PV array used in the system operates within the maximum peak power tracking (MPPT) operational window.

Voltage requirements

The solar array connected to the Sun Tie XR should have a minimum of 50 volts DC open-circuit in full sunlight conditions. Crystalline solar arrays configured for 48 volts DC nominal will have an open-circuit voltage of around 84 volts DC in full sunlight. The MPPT software controls the output of the solar modules, under loaded conditions, in the 42–85 volts DC range (full inverter output power occurs between 52–85 VDC for the STXR1500 and between 52–75 VDC for the STXR2500). Other array voltages will either not operate the inverter, may cause damage, or will not allow maximum harvest of the sun's energy.

Note: The MPPT algorithm does not work with wind power or batteries.



CAUTION

Although the nominal voltage range suggests that you can use strings of five modules in series, this is not safe for the unit, as the PV array may exceed the inverter's maximum input (120 VDC).



WARNING: SHOCK HAZARD

Whenever a PV array is exposed to sunlight, a shock hazard exists at the output cables or exposed terminals. To reduce the risk of shock during installation, cover the array with an opaque (dark) material before making any connections.

Installation

Overview

Installation steps

There are four main steps in the installation of the Sun Tie XR:

1. Mounting the unit
2. Making the DC connections from the PV array to the Sun Tie XR
3. Making the AC connections from the service utility panel to the Sun Tie XR
4. Grounding the PV array

This section also discusses two installation options: connecting inverters in parallel and connecting the Remote Monitor.



WARNING: FIRE, SHOCK and ENERGY HAZARDS

Before installing the Sun Tie XR, read all instructions and cautionary markings located in this manual, on the PV array, and on the main service panel.

Mounting

Surfaces for mounting

The Sun Tie XR must be mounted to a flat, vertical surface such as wallboard or wood siding. Installation onto wallboard or concrete requires the use of anchors to properly hold the screws.



WARNING: SHOCK HAZARD

Before drilling holes to mount the Sun Tie XR, ensure there are no electrical wires or plumbing in this area. Since this unit is installed close to the utility entrance or meter, there may be a high concentration of electrical wire in the area.



CAUTION

The Sun Tie XR weighs approximately 35 pounds. Always use proper lifting techniques during installation to prevent personal injury.

To mount the Sun Tie XR:

1. Locate the area where the Sun Tie XR is to be installed. Installing it as close to the utility service panel as possible is recommended. The *bottom* of the unit must be at least 36 inches from the floor or ground when mounted.
2. Using a level, place the mounting bracket up to the wall (in a horizontal position) and mark the area for the three screws, as shown in [Figure 2-4](#). To achieve the 36-inch height from the bottom of the Sun Tie XR to the ground, mount the bracket 70 inches from the ground.
3. If required, remove the bracket and drill the holes using a #10 (0.193" diameter) drill bit. Drill appropriately sized holes for anchors when installing on non-wood surfaces.
4. Mount the bracket to the wall using the screws and washers provided. If mounting to a surface other than wood, use the appropriate screws and anchors.
5. Place the Sun Tie XR's rear lip, located on the back top of the enclosure, over the bracket and ensure it is seated properly, as shown in [Figure 2-5](#).
6. Remove the lower external cover to access the internal circuit breaker panel by removing the screw on each side of the cover with a 3/32" hex bit, as shown in [Figure 2-6](#).
7. Remove the internal breaker panel by removing the screws in the breakers and the breaker cover grounding screw. Lift the panel until the lower locking tabs are free, then gently pull the inner cover outward, as shown in [Figure 2-7](#). Save the screws for reinstallation.
8. After the unit is correctly seated on the upper bracket, locate the two screw holes in the bottom (back) area of the enclosure and mark these locations on the wall, as shown in [Figure 2-5](#) and [Figure 2-8](#). Remove the Sun Tie XR (if required).
9. Drill two pilot holes (as above, if required).
10. Reinstall the Sun Tie XR to the bracket and secure the bottom of the unit with the wood screws and washers provided (or appropriate screws and anchors for non-wood surfaces) and tighten.

Note: Mounting hardware for surfaces other than wood is not supplied.



Figure 2-4 Bracket mounting

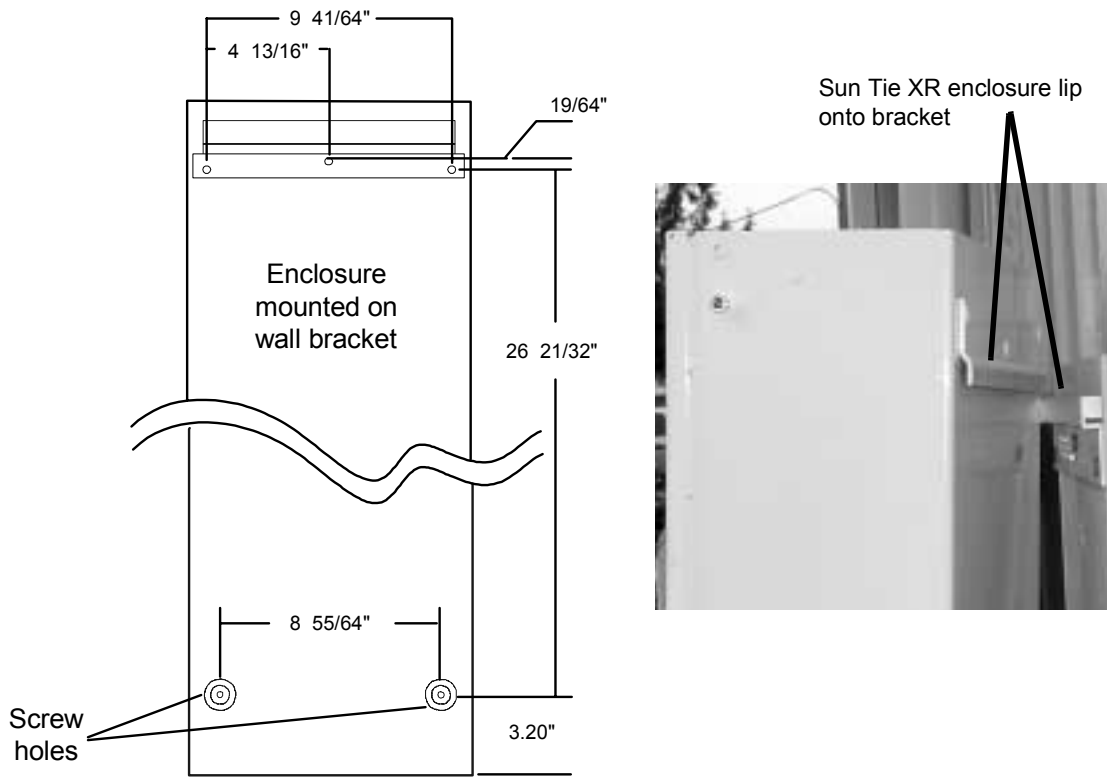

Figure 2-5 Enclosure mounting

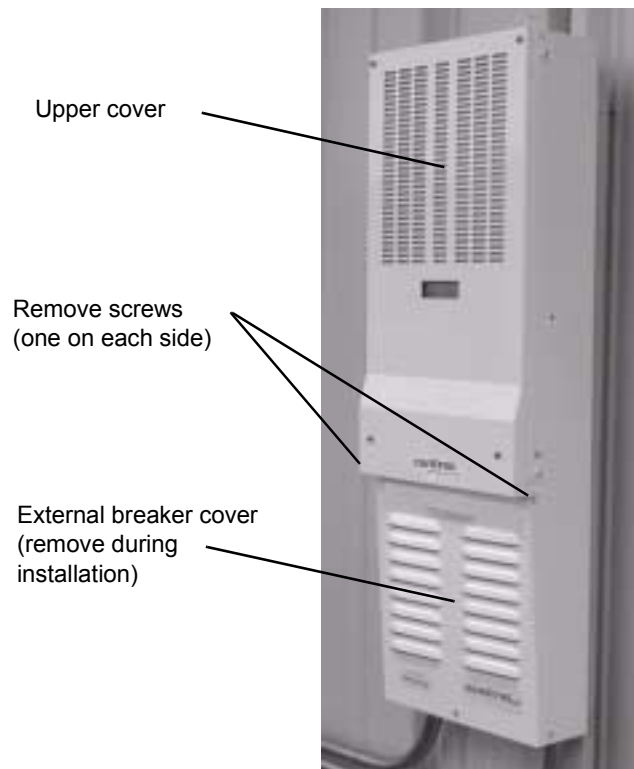

Figure 2-6 External cover components

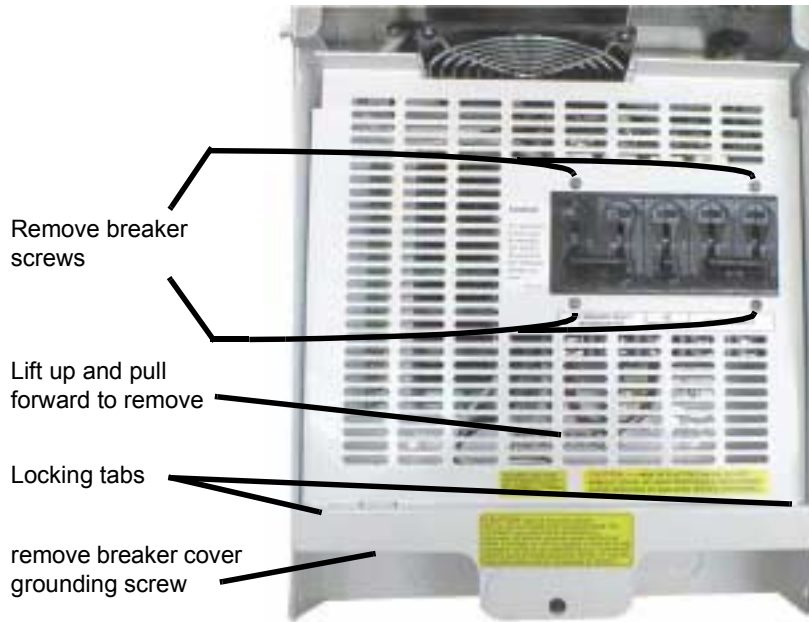

Figure 2-7 Inner breaker cover

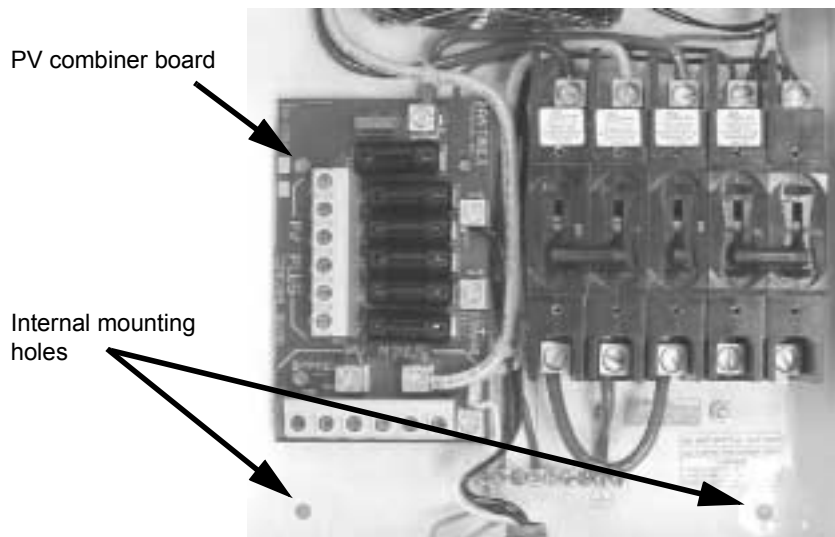

Figure 2-8 Mounting holes

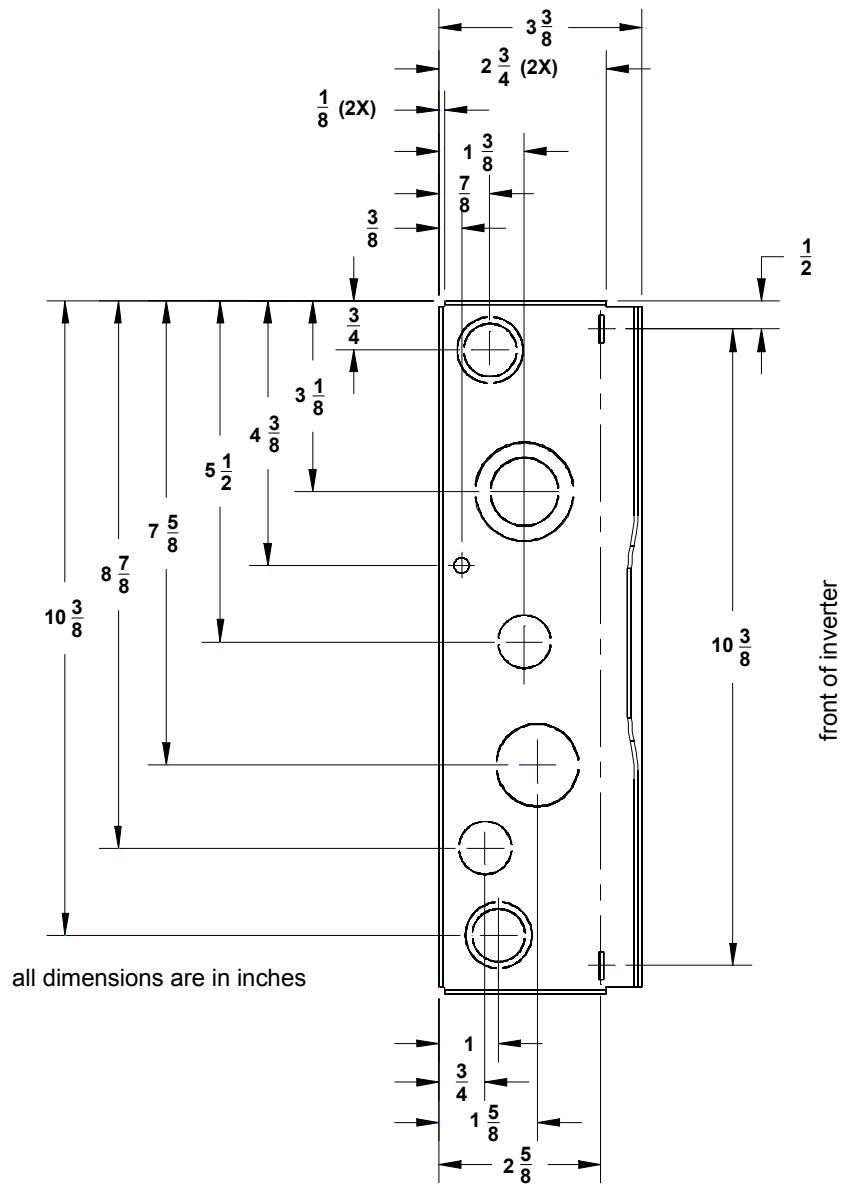

Figure 2-9 Bottom hole conduit locations (bottom view)

Connecting DC Wiring

Fuse requirements	The combiner board in the Sun Tie XR accepts up to six individual PV array circuits (positive and negative wires). Each circuit on the combiner board contains a fuse to protect against over-current. Always replace this fuse with one of the <i>same type and rating</i> (GBB, 20 amp maximum, ceramic type, 0.25" x 1.25"). The combiner board is rated for 100 amps maximum input.
Combiner board location	The combiner board PV array input connection block is located in the lower left-hand section of the Sun Tie XR unit.
Wiring procedure	Before connecting DC wiring, refer to Figure 2-10 .

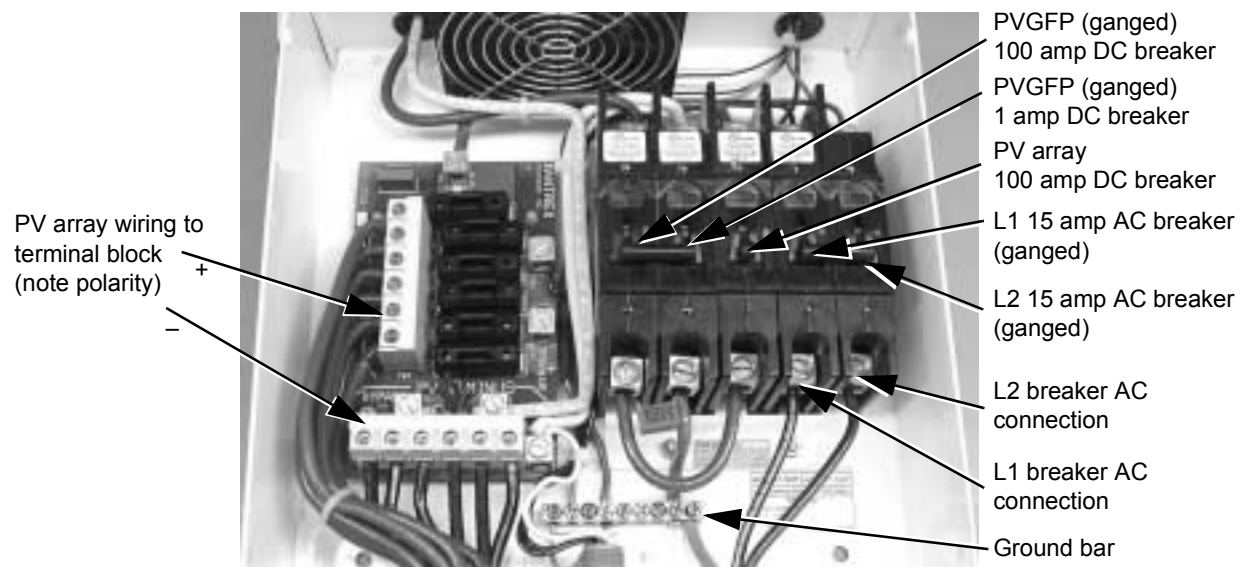

Figure 2-10 Electrical component location and PV array DC connection points

To wire the PV array to Sun Tie XR:

1. Install the DC conduit from the PV arrays to the bottom of the Sun Tie XR, through one of the knockout holes, as shown in [Figure 2-9](#). Metal conduit is highly recommended.
2. Route the wires from the PV array(s) through the conduit and into the lower section of the Sun Tie XR enclosure, as shown in [Figure 2-8](#).

Note: If you are using more than one PV sub-array, label the positive and negative wire pairs appropriately (such as PV 1, PV 2, and so on).

3. Connect the positive (+) wire from the #1 array to the PV PLUS 1 terminal on the combiner board. Check that the wire is in the proper location and tighten the screw.

4. Connect the negative (–) wire from the PV array to the PV MINUS 1 (leftmost) terminal. Check that the wire is in the proper location and tighten the screw.
5. Repeat this procedure for each PV array circuit, connecting the #2 PV positive wire to the terminal labeled PV PLUS 2, and so on.
The PV arrays do not have to connect in the order marked on the board (this is just for reference). All PV array positives on the combiner board are joined together AFTER the fuse.
6. Repeat this procedure for each PV array circuit, connecting the #2 PV negative wire to the PV MINUS 2 terminal, and so on.
The PV arrays do not have to connect in the order marked on the board (this is just for reference). All PV array negatives on the combiner board are electrically tied together.
7. Torque wires according to the following values.

Wire Size (AWG)	Torque (in-lb)
14–10 AWG	35
8 AWG	40
4–6 AWG	45
2–1/0 AWG	50

Connecting AC Wiring

AC HOT wiring is connected to the Sun Tie XR’s L1 and L2 breakers, and the ground wire connects to the ground bar. All AC wiring is located in the lower section of the Sun Tie XR.



WARNING: SHOCK HAZARD

AC utility wiring to the Sun Tie XR unit is performed directly at the main breaker panel. This should be done only by a qualified utility installer or electrician with prior utility company approval.

Note: The Sun Tie XR can be connected to a single bidirectional meter, or to dual meters, where one meter indicates power used and the second meter indicates power sold (power supplied back to the utility). The installer and utility must determine the proper components to install.

**WARNING: SHOCK HAZARD**

Before wiring the Sun Tie XR, ensure the main 120/240 volt breaker in the main utility breaker box is switched off. Switch this breaker on only after all wiring is completed as instructed in the procedures.

To wire the main utility panel to the Sun Tie XR:

1. Run conduit from the main utility breaker panel to the lower section of the Sun Tie XR. Run the two HOT wires (L1 and L2) and ground through the conduit and into the Sun Tie XR's lower section. Metal conduit is highly recommended.
2. Install or use existing double-pole 15-amp circuit breaker (or two single-pole 15-amp breakers, ganged) in the main utility breaker panel.
3. Connect the L1 HOT wire (black) from the 15-amp, double-pole breaker installed in the main breaker panel, to the breaker labeled L1 in the Sun Tie XR. Refer to [Figure 2-11](#).
4. Connect the L2 HOT wire (red) from the remaining 15-amp, double-pole breaker installed in the main breaker panel, to the breaker labeled L2 in the Sun Tie XR.
5. Connect the ground wire (green or bare copper) from the ground bar in the main breaker panel, to the ground bar in the lower section of the Sun Tie XR.
6. Ensure all connections are correctly wired and properly torqued.
7. Torque wires according to the following values.

Wire Size	Torque (in-lb)
14–10 AWG	35
8 AWG	40
6 AWG	45

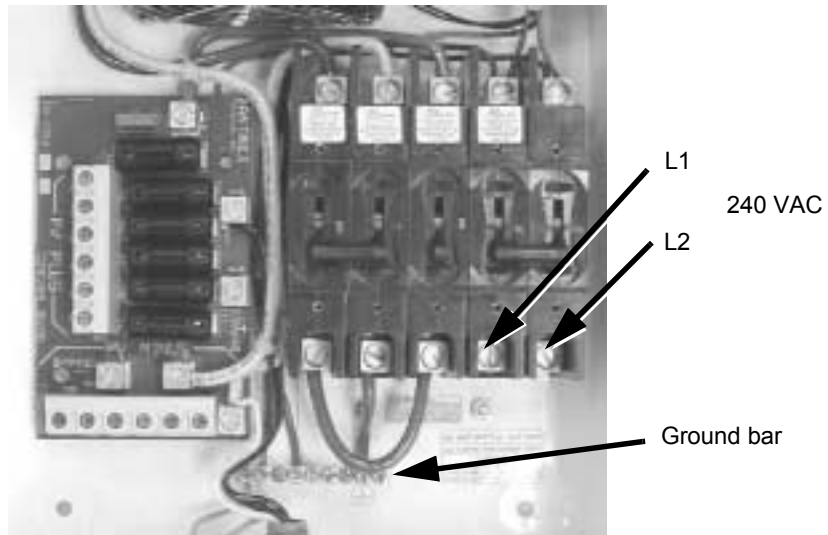

Figure 2-11 240 VAC connection points

Grounding the System

PV grounding

The Sun Tie XR is designed to have all PV positive, negative and ground conductors connected inside its access area. The PV equipment ground should be connected to the Sun Tie XR ground bar. This ground bar must also be connected to the main utility breaker panel's ground bar and to the house grounding rod according to the NEC requirements. Verify that there is an AC ground/neutral bond in the main utility breaker panel and that *no* other ground/neutral bonds exist in the system.

Lightning protection

To protect the equipment from lightning damage, use a single-point grounding system. In this system, all ground lines terminate at the same point. This point normally is the main utility ground installed by the utility company to provide a ground for the house wiring. This ground usually consists of a copper rod driven 6 to 8 feet into the earth, as shown in [Figure 2-12](#).

Recommended additional grounding

Xantrex recommends that if the inverter is more than 8 feet from the utility ground rod, a second ground rod should be added (Reference NEC 250.56) and bonded to the same point (Reference NEC 250.58) to minimize the impedance to ground and maximize system protection.

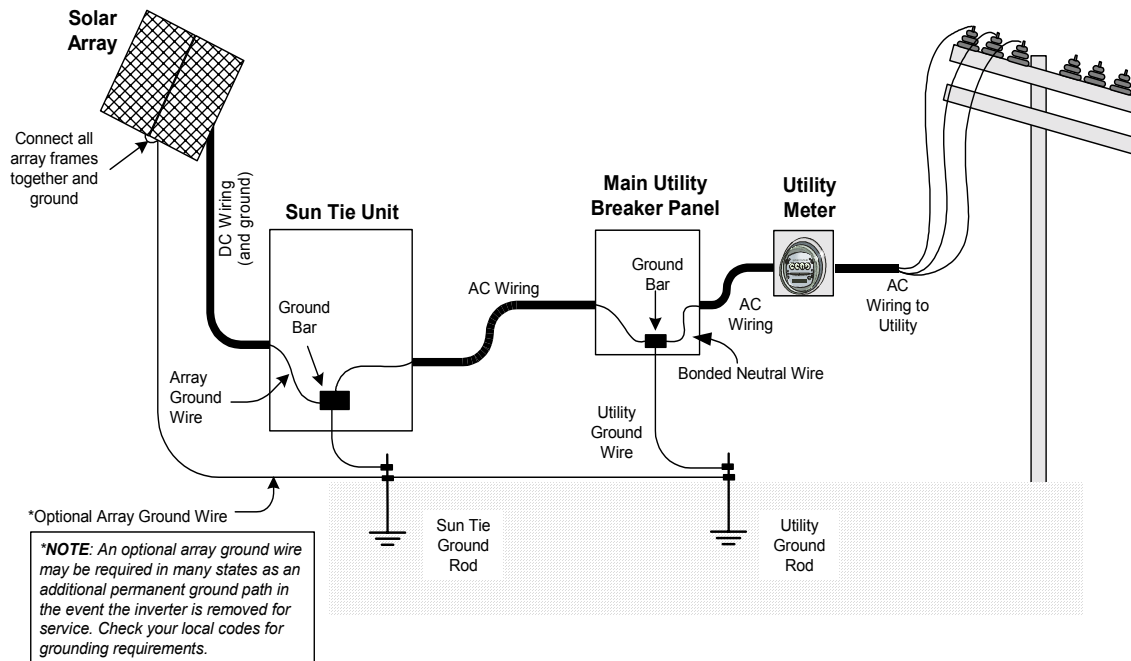

Figure 2-12 Typical roof mount installation grounding

Required additional grounding

If the PV array is located a considerable distance (over 100 feet) from the Sun Tie XR, then an additional ground rod must be installed close to the PV array for the most reliable lightning protection, as shown in Figure 2-13. The grounded frame of the PV array provides a direct route to dissipate lightning strikes through the closest ground rod. Please reference NEC 2002 250.53 – “Grounding Electrode System Installations” and NEC 2002 250.70 – “Methods of Grounding and Bonding Conductor Connections to Electrodes” for specific grounding requirements.

Note: Always refer to your local codes for wiring and grounding requirements, which may differ from the information given in this manual.

Installation

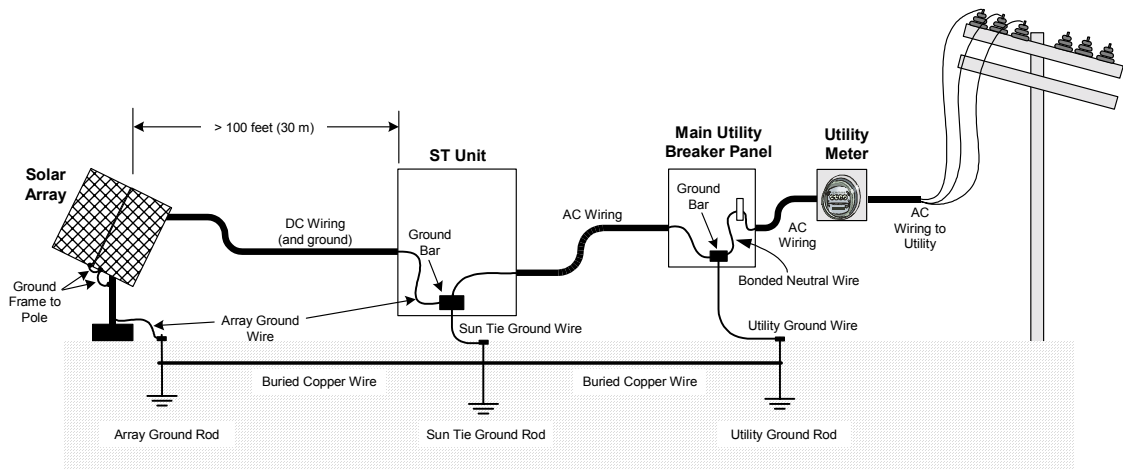

Figure 2-13 Long distance grounding

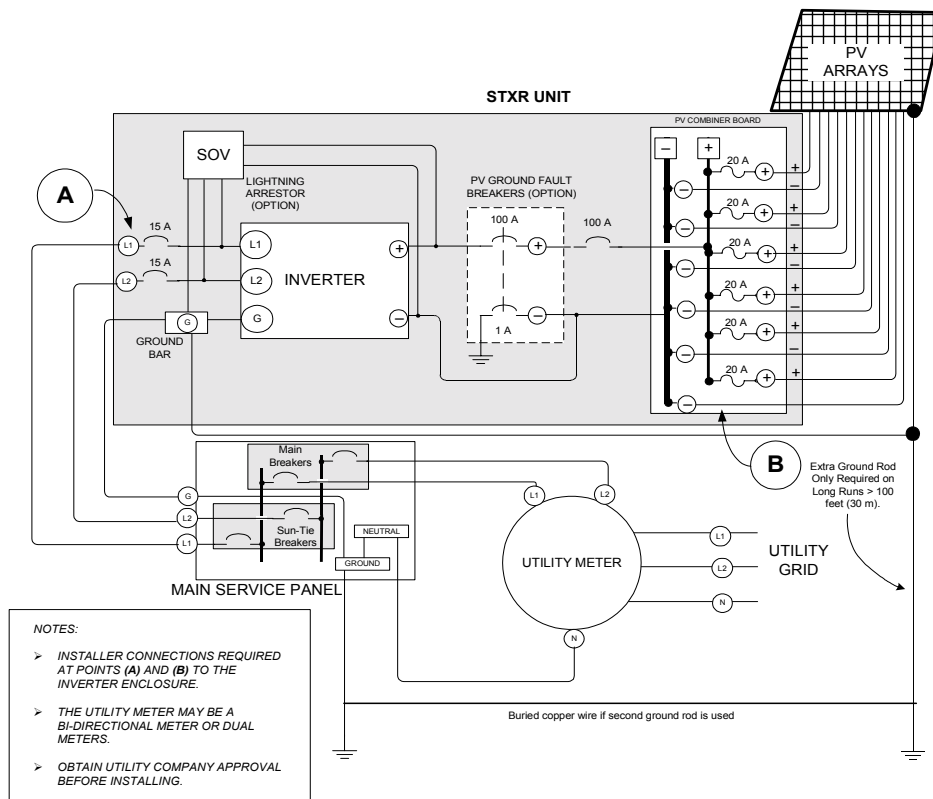

Figure 2-14 Simplified electrical wiring diagram

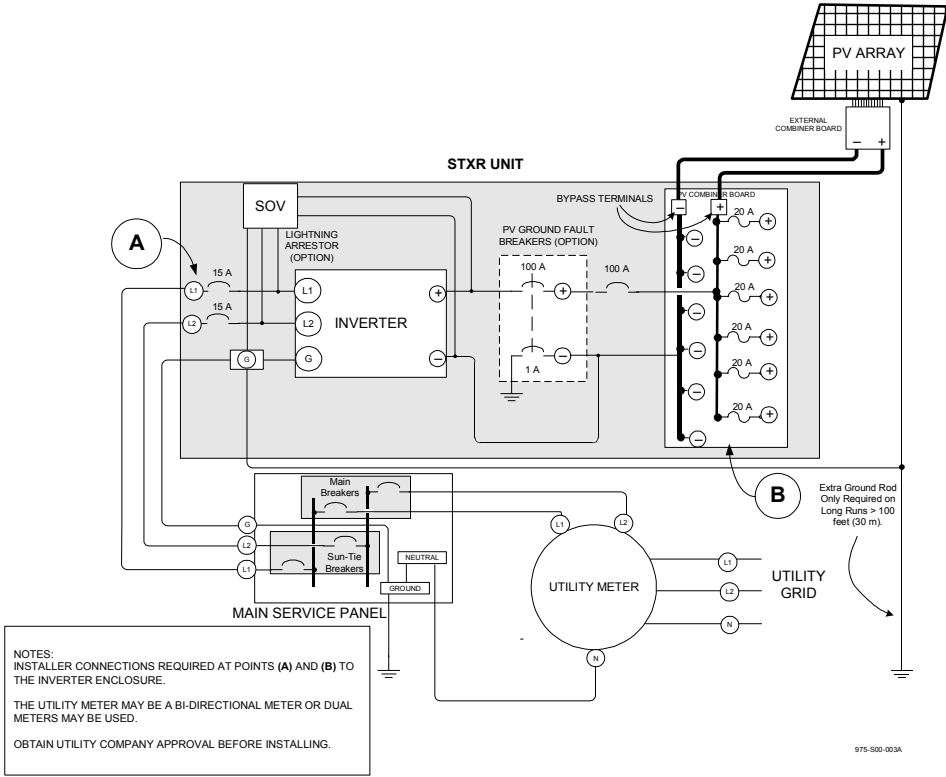

Figure 2-15 Simplified electrical wiring diagram (using PV bypass terminals)

Connecting Inverters in Parallel

Reasons and requirements

Sun Tie XR inverters may be connected in a parallel configuration to harvest additional energy from the sun. In this configuration, a separate solar array is required for each Sun Tie XR unit. The output of each Sun Tie XR feeds a dual-pole 15-amp circuit breaker (L1 and L2) in the main utility breaker panel.

Connecting AC and DC wiring

The procedure for wiring the additional Sun Tie XR is exactly the same as previously described for the AC and DC wiring. Additional Sun Tie XR inverters can be added in the future as required.

An example of a parallel configuration is shown in [Figure 2-16](#).

Note: If you are combining two Sun Tie XR inverters into a single dual-pole breaker (30 amp, for example), you will need to size the AC wires and conduit to the larger breaker. If this breaker trips, it will also shut down both inverters. For these reasons, we do not recommend using a single dual-pole breaker.

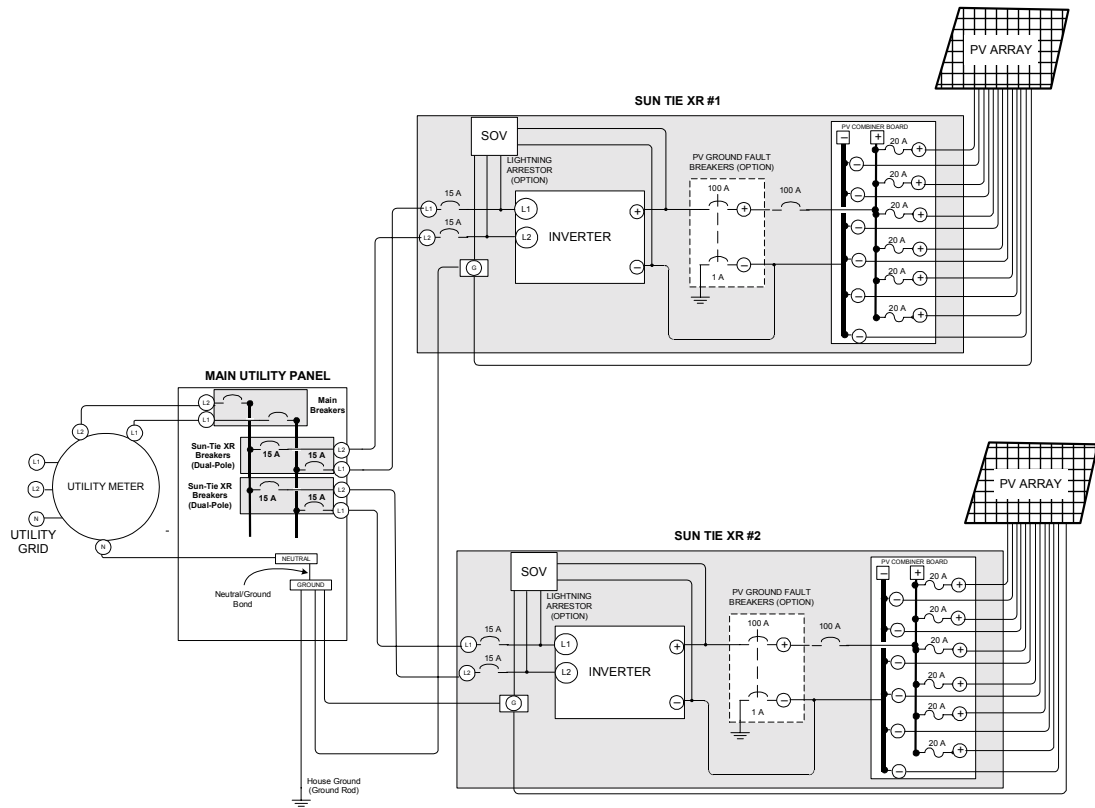

Figure 2-16 Parallel Sun Tie XR configuration

Installing the Optional Remote Monitor

Remote Monitor function

The optional Remote Monitor provides additional functions which are not directly available on the front panel LCD display. It can be mounted in a more accessible location such as the garage, kitchen, living room, and so on. Refer to the “Sun Tie XR Series Remote Monitor Installation and Operator’s Guide” (part number 975-0032-01-02) for installation details.

To wire the Remote Monitor to the Sun Tie XR:

1. Route the Remote Monitor's six-conductor cable separate from the other wiring to prevent noise and interference from being introduced into the data cable. Refer to [Figure 2-17](#) and [Figure 2-18](#). The connector is located in the upper right-hand section of the wiring compartment.

**CAUTION**

When routing the Remote Monitor cable, do not use a metal conduit. Metal conduit may induce noise in the remote cable and cause scrambled data to appear on the display.

-
2. Run the cable through one of the lower knockouts (with a strain relief installed) and plug it into the Remote Monitor port.
 3. Recheck all wiring and reinstall the panels and the Rain Shield (if used).

**CAUTION**

The P.C. com. port next to the Remote Monitor port is not enabled. Connecting a computer to this port may result in damage to the inverter or the computer.

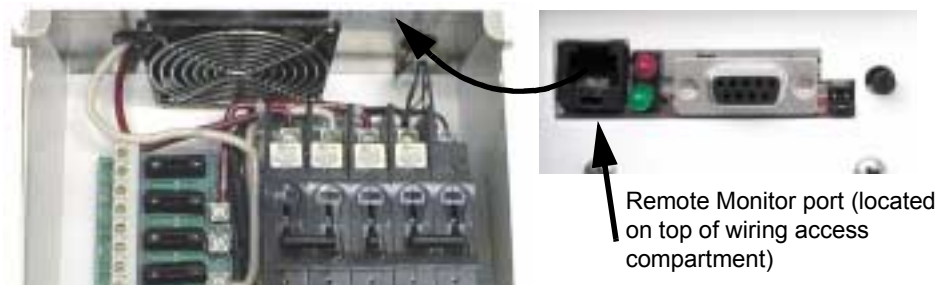

Figure 2-17 Location of optional Remote Monitor port



Figure 2-18 Remote Monitor connection and cable

3

Operation

Chapter 3, “Operation” provides procedures for starting up and operating the Sun Tie XR. It also explains the messages that appear on the front panel display. The chapter ends with information about factors that affect how much power the Sun Tie XR can gather from the PV array and deliver to the utility grid.

Startup Procedure

Starting up the Sun Tie XR requires several steps. You will need to:

1. Check the PV array DC voltage.
2. Check the AC utility voltage.
3. Start up the Sun Tie by switching on the DC and AC circuit breakers inside the unit.
4. Reassemble the Sun Tie XR and replace the external covers.

Required Equipment

You will need the following equipment to help you start up the Sun Tie XR:

- AC voltmeter (or multimeter)
- DC voltmeter (or multimeter)
- Frequency counter (optional)



WARNING: SHOCK HAZARD

Hazardous voltages present from two sources. Use extreme caution during startup procedure. Before applying power to the Sun Tie XR, ensure all AC and DC wiring is correct.

Checking the PV Array DC Voltage

To check the PV array DC voltage:

1. Uncover the PV arrays and expose them to full sunlight. The sunlight must be intense enough to produce the required output voltage.
2. Measure the PV array open circuit DC voltage across the DC positive (+) and negative (-) terminals as shown in [Figure 3-1](#). This voltage must be greater than 50 volts DC for 5 minutes minimum to start the inverter.

Note: Some thin film modules (amorphous) may produce open circuit voltages from 100–120 volts. Crystalline solar modules will produce open circuit voltages at 75–85 volts (four modules wired in series). An open circuit voltage of 50 volts or more is required for 5 minutes to start the inverter. The 5-minute time delay is required by safety standards.

3. Switch on the PVGFP and DC breakers.

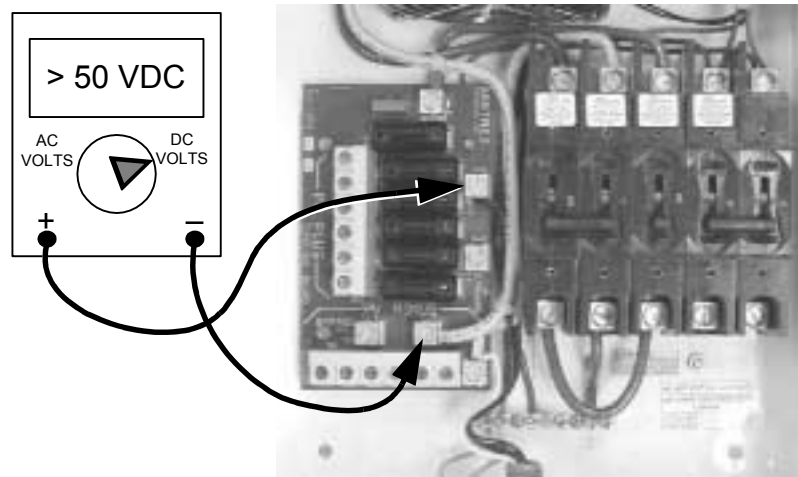

Figure 3-1 PV array DC voltage test

Checking the AC Utility Voltage

Note: The Sun Tie XR is designed primarily for residential applications. For commercial applications where only 208 VAC is available, the Sun Tie XR may be installed with the appropriate use of a buck-boost transformer.

To check the AC utility voltage:

1. Switch on the main 240 V breakers in the building's electrical service panel.
2. Ensure all circuit breakers located in the Sun Tie XR unit are in the off (down) position.
3. Using an AC voltmeter, measure the AC open circuit utility voltage between L1 and L2, as shown in [Figure 3-2](#). Ensure this voltage is approximately 240 volts AC. The inverter operates with a line-to-line voltage (L1 to L2) ranging from 211–264 volts AC.
4. Switch on the ganged 15 amp Sun Tie XR circuit breakers located in the main electrical service panel. This applies the utility-supplied 240 volts AC to the Sun Tie XR unit.

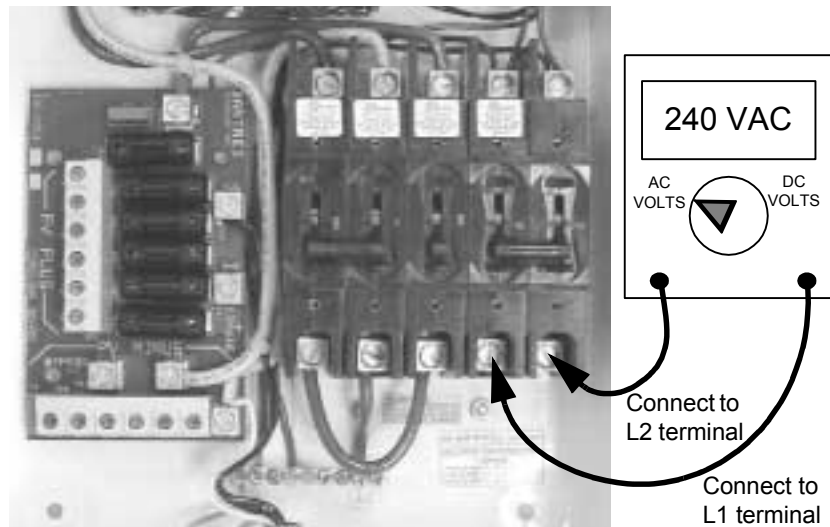

Figure 3-2 AC voltage test

Starting up the Sun Tie XR

To start up the inverter:

1. Switch on the 100-amp DC circuit breaker located in the Sun Tie XR unit. This breaker supplies the DC power from the PV array to the Sun Tie unit. Refer to [Figure 3-3](#), item 1.
2. Switch on the 1 and 100 amp (ganged) PVGFP breakers. These breakers open when 1 amp or greater is detected in the DC negative-to-ground line; indicating a ground fault condition. Refer to [Figure 3-3](#), item 2.
3. Switch on the double-pole 15 amp AC circuit breakers located in the Sun Tie XR unit. These breakers provide the Sun Tie XR-produced power to the utility and provide the necessary utility voltage and frequency to the inverter. This means the inverter will not produce an AC output if utility voltage is not present on its output. Refer to [Figure 3-3](#), item 3.

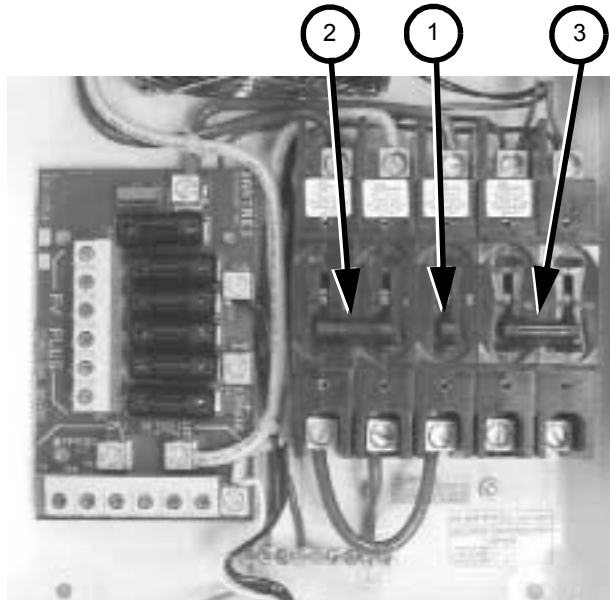

Figure 3-3 Startup sequence

Monitoring the Front Panel Display

During startup	During startup, the inverter's front panel LCD display shows the first four messages described in "Reading the Front Panel Display" .
During waiting period	When the five-minute timer begins, the inverter displays the countdown timer status meter.
During operation	When the five-minute wait protection timer stops, the Sun Tie XR begins selling power, indicated by the power output reading in the display. The array "Wh" values will increase slowly, depending on the array size and sunlight intensity.

Note: The values in the front panel LCD display are calibrated at the factory. The calibration is not user-adjustable.

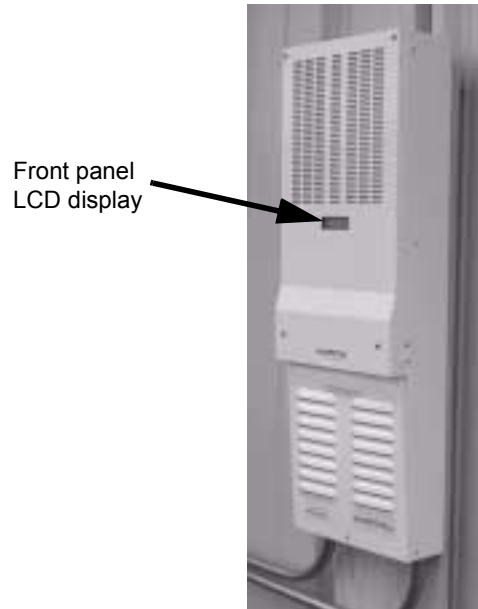

Figure 3-4 Front panel display location

Reading the Front Panel Display

During startup

During startup, the Sun Tie XR will display several messages on its front panel LCD display. These messages appear in the following order.

Message	Display Duration
XANTREX TECH INC. STXR2500 (or “STXR1500”)	8 seconds
Enhanced with Sun Sweep	
CPU Rev = x.x LCD Rev = x.x	
244 vac 74 vdc Start in 300 sec	Cycles with the Lifetime Energy and Time Online messages for five minutes. See “After startup” .

After startup

After the 300-second countdown timer and during normal operation, the Sun Tie will display four messages that repeat every minute.

Message (with sample data)	Display duration (seconds)	Description
54 mppt 74 vdc 2500 W 12123 Wh*	0 – 8	Message 1 shows the inverter’s DC regulation voltage for maximum power production, DC input voltage, power output, and energy harvested today.
244 vac 74 vdc 2500 W 12123 Wh*	8 – 16	Message 2 shows AC input voltage, DC input voltage, the power output and energy harvested today.
	16 – 24	Repeats message 1.
	24 – 28	Repeats message 2.
Lifetime Energy 10.000kWh	28 – 32	Message 3 shows the amount of energy produced since installation and startup.
	32 – 40	Repeats message 1.
	40 – 48	Repeats message 2.
	48 – 56	Repeats message 1.
Time Online Today 00:00:00	56 – 60	Message 4 shows how long the Sun Tie has been online since it last started.

*If the inverter is disconnected due to a line condition, this display will show one of the following messages:

- AC NOT PRESENT
- AC MAINS LOW
- AC MAINS HIGH
- FREQUENCY FAULT

Status Indicator Lights

The Sun Tie XR is equipped with two status indicator lights (LEDs) above the circuit breakers inside the wiring compartment. These light during operation to indicate the inverter’s current status. For information about reading these lights, see [Chapter 4, “Troubleshooting”](#).

Reassembling the Sun Tie XR

Once the Sun Tie XR is operating normally and producing power, you need to replace the panels and covers that were removed during installation and startup.



WARNING: SHOCK HAZARD

Before reattaching covers, remove AC power at the utility panel and cover the PV arrays.

To reassemble the Sun Tie XR:

1. Replace the circuit breaker panel, as shown in [Figure 3-5](#).
 - a) Install the circuit breaker (inner) panel by sliding it into place under the top cover and fitting its two locking tabs into the slots on the bottom of the Sun Tie XR.
 - b) Secure the front panel to the circuit breaker with the four screws.
 - c) Replace the breaker cover grounding screw.
2. Replace the external cover by positioning the external cover in place as shown in [Figure 3-6](#) and installing a screw in each side.

Note: To prevent tampering or unauthorized access to the unit, install a lock through the hole at the bottom front of the external cover and the main chassis.

3. Install the Rain Shield if the Sun Tie XR is located outdoors, as shown in [Figure 3-7](#).
 - Place the Rain Shield onto the Sun Tie XR enclosure.
 - Secure it with the four screws provided (two each side).

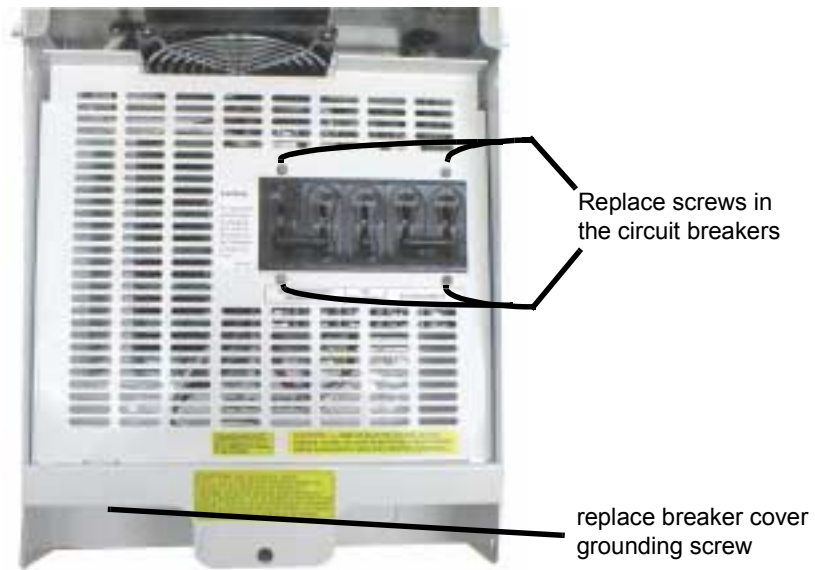

Figure 3-5 Circuit breaker cover and screws

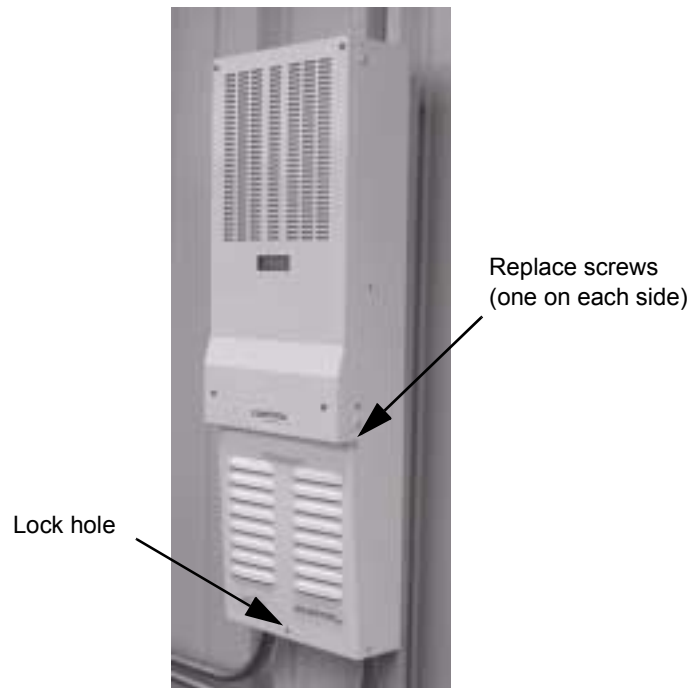

Figure 3-6 Outer cover and screws



Figure 3-7 Rain Shield and screws

Factors Affecting Sun Tie XR Performance

This section describes several factors that will affect the amount of power that a properly installed and operating Sun Tie XR can produce.

PV Array Factors

PV array ratings

PV arrays are rated at ideal factory conditions, such as specified illumination (1000 W/m^2), spectrum of the light and specified temperature ($25 \text{ }^\circ\text{C}/77 \text{ }^\circ\text{F}$), which seldom reflect real-world installations. This is called the STC (Standard Test Condition) rating and is the figure that appears on the PV module nameplate label.

Expected performance

Because of several unavoidable environmental factors, you can expect your PV array to produce around 60% to 70% of its peak STC-rated output for a properly designed and installed PV system.

Temperature and reduced output	<p>PV array temperature affects the output of the entire system. As the temperature on the array surface heats up, its energy output goes down. Roof-mounted arrays also collect the heat generated by the roof surface (or trapped under the array) and will produce less output than pole-mounted arrays, which allow greater air circulation behind the panels.</p> <hr/> <p>Note: The Sun Tie XR will reduce its energy output to protect its electronic circuits from overheating and possible damage in high heat conditions. For maximum output in hot climates, mount the Sun Tie XR in a shaded location with good air flow.</p> <hr/>
Angle of the sun	<p>The angle of the sun in relation to the PV array surface—the array orientation—can dramatically affect the PV array output. The array energy output will vary depending on the time of day and time of year as the sun’s angle in relation to the array changes. Sunlight output decreases as the sun approaches the horizons (such as in winter in North America) due to the greater atmospheric air mass it must penetrate, reducing both the light intensity that strikes the array’s surface and spectrum of the light. In general, you can expect only four to six hours of direct sunlight per day.</p>
Partial shade	<p>Shading of only a single module of the array will reduce the output of the entire system. Such shading can be caused by something as simple as the shadow of a utility wire or tree branch on part of the array’s surface. This condition, in effect, acts like a weak battery in a flashlight, reducing the total output, even though the other batteries are good. However, the output loss is not proportionate to shading.</p> <p>The Sun Tie XR is designed to maximize its energy production in all of the above situations using its MPPT algorithm.</p>

Other Factors

Other factors that contribute to system losses are:

- Dust or dirt on the array
- Fog or smog
- Mismatched PV array modules, with slight inconsistencies in performance from one module to another.
- Inverter efficiency
- Wire losses
- Utility grid voltage

For additional information and technical notes concerning PV array performance, please visit our Web site at www.xantrex.com.

4

Troubleshooting

Chapter 4, “[Troubleshooting](#)” describes how to view the status indicator lights (LEDs) inside the Sun Tie XR and use them to troubleshoot the unit. It also provides troubleshooting information with suggestions for solving the problems that the lights may indicate.

Troubleshooting the Sun Tie XR

Viewing the Status LEDs

Inverter status
LEDs

To aid in troubleshooting the Sun Tie XR, there are two red and green lights (LEDs) inside the unit. The LEDs light to indicate the inverter's status according to the troubleshooting reference table on [page 4-5](#).

Viewing the status LEDs inside the unit should only be performed by an authorized service person. If you suspect your unit is not functioning correctly, call Xantrex.



WARNING: SHOCK HAZARD

Do not remove the upper cover. Dangerous voltages exist in the upper cover area.

To view the status LEDs:

1. Remove the Rain Shield (if installed) by removing the four screws (two from each side) securing it to the housing as shown in [Figure 4-1](#). Set the screws aside in a safe place.
2. Remove the lower external panel by removing the two screws on either side of the panel as shown in [Figure 4-1](#). Set the screws aside in a safe place.
3. Locate the red and green LEDs. They should be visible through the upper edge of the circuit breaker cover (see [Figure 4-2](#)).
4. Refer to the troubleshooting reference table on [page 4-5](#) for the LED status indications.

Note: The optional Remote Monitor (STRM) has a two-color LED that duplicates the function of the status LEDs inside the unit. For troubleshooting the Sun Tie XR, we recommend using the Remote Monitor.

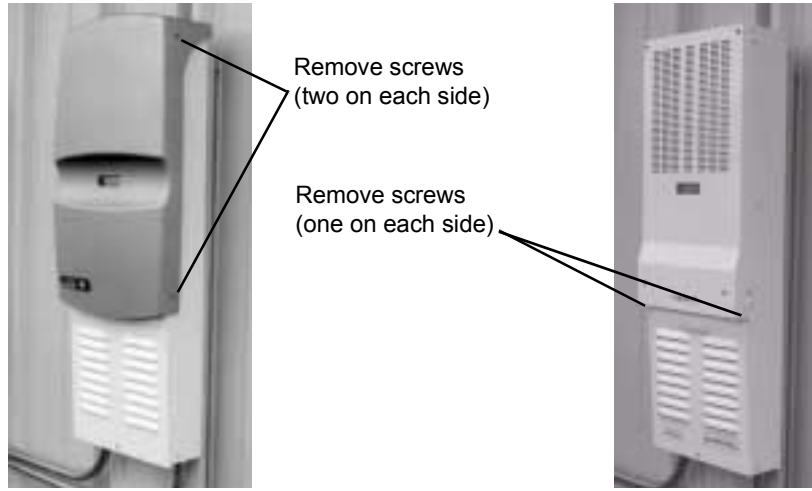

Figure 4-1 Rain Shield and lower panel removal

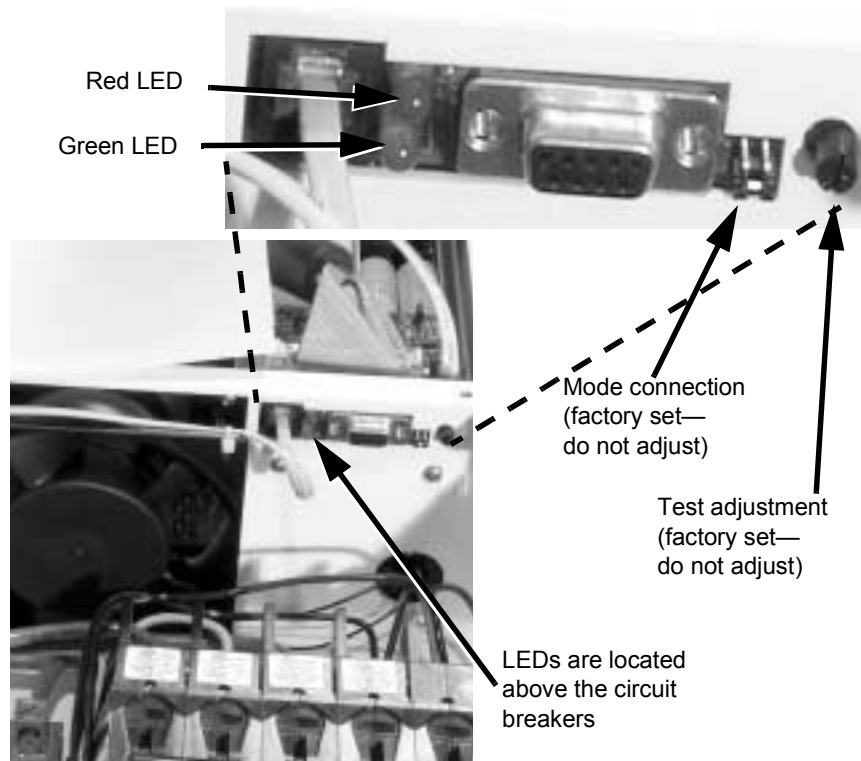

Figure 4-2 Status LEDs location (with circuit breaker cover removed)



CAUTION

The P.C. com. port next to the status LEDs is not enabled. Connecting a computer to this port may result in damage to the inverter or the computer.

Troubleshooting Reference Table

Problem	Cause	Remedy
Inverter CPU does not illuminate the red or green LEDs and does not operate in sufficient sunlight, or the display reads “AC Mains Not Present” or the VDC reading is 0.	<p>PVGFP, AC or DC breakers are switched off.</p> <p>No AC grid or DC array voltage is present.</p> <p>20 amp fuses on combiner board are missing or open.</p>	<p>Turn on breakers in the sequence described in the operation section.</p> <p>Check AC connections and ensure 240 VAC is present at the inverter’s AC disconnect. Check DC connections and ensure 50–125 VDC is present on the inverter’s disconnect.</p> <p>Install combiner board fuses. Check PV array for short circuits or improper sizing for the 20 amp fuse.</p>
The inverter CPU only illuminates the red LED. The green LED never illuminates in a flashing or solid mode, or the display reads “AC Mains Not Present” or the VDC reading is 0.	<p>The inverter does not recognize any AC input signal.</p> <p>Inverter does not recognize the appropriate DC signal.</p>	<p>Ensure the inverter AC disconnect is switched on. Check the AC voltage at the inverter and ensure AC voltage is present. Check source of the AC voltage.</p> <p>Check the DC voltage on the positive and negative input terminals. The DC voltage must be 50 volts or greater open circuit to initiate inverter operation. Check for incorrectly wired PV arrays or try again on a day with brighter sunlight intensity.</p>
The inverter illuminates the red LED upon startup and goes into a flashing green mode. The flashing green LED continues for over 5 minutes and never illuminates solid.	The inverter recognizes the AC grid is present, but grid voltage or frequency are not within the appropriate tolerances.	Check the AC voltage and frequency with a multimeter/frequency meter. Wait for grid power to return to acceptable voltage and/or frequency. Notify the utility company that the voltage or frequency is outside of the appropriate boundaries.
The inverter CPU illuminates a solid green LED momentarily, then flashes a red LED.	The inverter recognizes the AC grid and DC array voltages and attempts to start selling power. The PV panels are not producing sufficient power for the inverter to operate at a stable DC voltage.	Check the DC input voltage at the inverter’s positive and negative input terminals. The PV array is not producing enough power. Wait for sunlight intensity to increase and ensure the panels produce sufficient voltage for inverter initialization.

Troubleshooting

Problem	Cause	Remedy
100 amp DC breaker trips.	Current from the array exceeds the DC input breaker rating. A lightning strike hit near the PV array.	Check array size and ensure the DC input does not exceed the breaker rating. Check lightning arrestor, breakers, panels, diodes, DC wire insulation and other components for damage. Replace any damaged components and reset the breaker.
Open 20 amp combiner board fuse(s).	A short to ground exists in the DC array wiring. Array is producing current in excess of the fuse rating.	Check all DC array wiring for improper wiring or exposed wires. Check array size and ensure the DC input current does not exceed the fuse rating.
PVGFP breaker trips.	A ground fault exists in the DC array wiring.	Check all PV array wiring for improper wiring, exposed wires, or short circuits.

A

Specifications

[Appendix A](#) contains the electrical and mechanical specifications for the Sun Tie XR. These include the AC output ranges and characteristics, operating temperature ranges, dimensions, and weight. [Appendix A](#) also lists standard features, options, and regulatory information for the Sun Tie XR.

Electrical Specifications

AC output voltage	240 VAC
AC output voltage range	211–264 VAC
Continuous AC output at 32–113 °F (0–45 °C)	1500 VA (STXR1500), 2500 VA (STXR2500)
Efficiency (peak)	91%
AC output characteristics	Current source
Frequency	60 Hz (+0.5 Hz, -0.7 Hz)
Wakeup DC voltage	50 VDC
Input voltage (nominal)	48 VDC (4 nominal 12 VDC PV modules in series)
Absolute maximum PV open circuit voltage (Voc)	120 VDC
Sunsweep™ MPPT voltage range	42–85 VDC
DC voltage range for full-rated VA	52–85 VDC (STXR1500), 52–75 VDC (STXR2500)
AC output waveform	Sine wave, high frequency PWM controlled
Total harmonic distortion (current)	less than 5% at rated power
Nighttime tare loss	5 W
Minimum array size (STC rating)	480 W

Mechanical Specifications

Specified temperature range	Operating: -38 to 113 °F (-39 to 45 °C) Listed to: 32 to 113 °F (0 to 45 °C)
Enclosure type	Outdoor, rainproof (with Rain Shield), powder-coated aluminum enclosure, fully screened
Inverter dimensions (H × W × D)	33.25" × 13.25" × 5.3" (83.1 cm × 33.8 cm × 13.25 cm)
Shipping dimensions (H × W × D)	37.75" × 15.75" × 9.5" (94.4 cm × 39.4 cm × 23.8 cm)
Weight (inverter only)	35 lb (15.9 kg)
Weight (shipping)	40 lb (18 kg)
Mounting	Vertical wall mount only

Standard Features and Options

Feature	Description
PV ground fault protection system	Standard
PV combiner board with 6 fused inputs, 20 amps maximum per input	Standard
Lightning arrestor-combined AC/DC protection	Standard
Rain Shield	Optional STRS protective Rain Shield (required for outdoor installation), which makes the Sun Tie XR a rainproof Type 3R enclosure.
STRM—remote meter	Optional remote display with user-resettable Wh meter, tech menu, and dynamic user display. Includes 50 foot (15.2 m) cable.
Forced air cooling	Standard forced-air AC brushless fan (eight-speed, thermally controlled)
Islanding protection	Active islanding protection with over/under AC voltage and frequency detection
User display	Dynamic backlit alphanumeric liquid crystal display with system AC/DC voltages, power, energy, and time online details
AC disconnect	Standard double-pole, 15 amp, 240 VAC branch-rated circuit breaker
DC disconnect	Standard single-pole, 100 amp, DC-rated circuit breaker
Listings	UL Listed to UL1741–1999 (first edition) and cUL Listed to CSA C22.2 No. 107.1-95 NEC 690 building code requirements for PV may be met with the standard ground fault protection (PVGFP) system.

Efficiency Curve

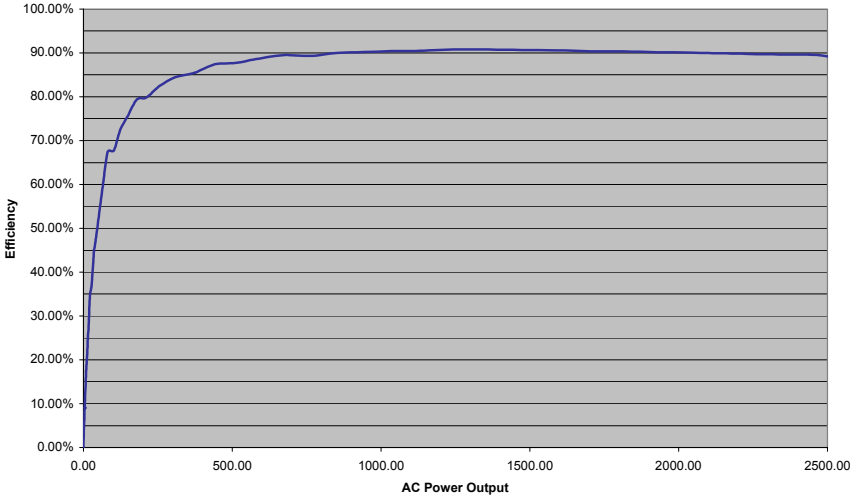

Figure A-1 Sun Tie XR efficiency curve

Temperature Derating Curve

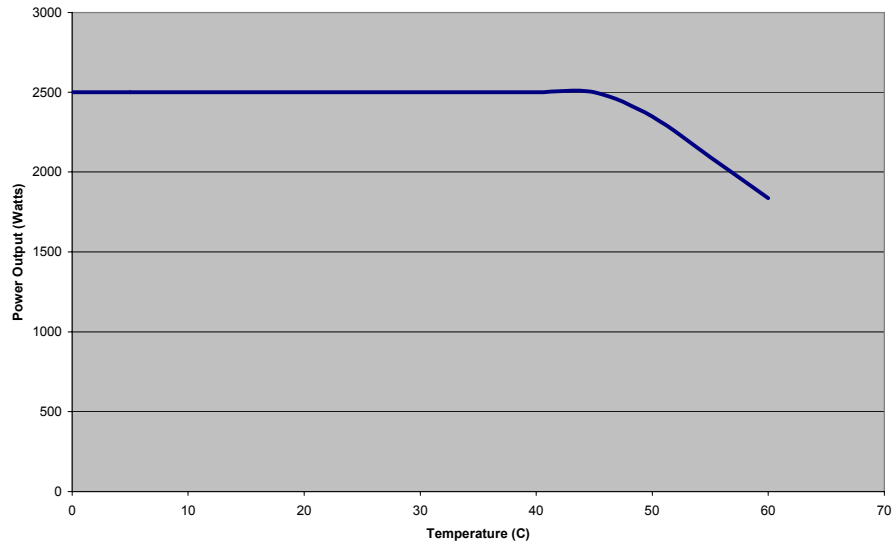

Figure A-2 Sun Tie XR2500 temperature derating curve*

*from our testing, these are the expected output characteristics to 60 °C with Rain Shield installed. Thermal characteristics are enhanced if the unit is installed indoors with no Rain Shield attached.

B

Warranty and Product Information

[Appendix B](#) contains warranty and return procedure information for the Sun Tie XR.

Limited Warranty

What does this warranty cover? This Limited Warranty is provided by Xantrex Technology, Inc. ("Xantrex") and covers defects in workmanship and materials in your Xantrex Sun Tie XR. This warranty lasts for a Warranty Period of two (2) years from the date of purchase at point of sale to you, the original end user customer.

This Limited Warranty is transferable to subsequent owners but only for the unexpired portion of the Warranty Period.

What will Xantrex do? Xantrex will, at its option, repair or replace the defective product free of charge, provided that you notify Xantrex of the product defect within the Warranty Period, and provided that Xantrex through inspection establishes the existence of such a defect and that it is covered by this Limited Warranty.

Xantrex will, at its option, use new and/or reconditioned parts in performing warranty repair and building replacement products. Xantrex reserves the right to use parts or products of original or improved design in the repair or replacement. If Xantrex repairs or replaces a product, its warranty continues for the remaining portion of the original Warranty Period or 90 days from the date of the return shipment to the customer, whichever is greater. All replaced products and all parts removed from repaired products become the property of Xantrex.

Xantrex covers both parts and labor necessary to repair the product, and return shipment to the customer via a Xantrex-selected non-expedited surface freight within the contiguous United States and Canada. Alaska and Hawaii are excluded. Contact Xantrex Customer Service for details on freight policy for return shipments outside of the contiguous United States and Canada.

How do you get service? If your product requires troubleshooting or warranty service, contact your merchant. If you are unable to contact your merchant, or the merchant is unable to provide service, contact Xantrex directly at:

Phone:360.435.8826

Fax:360.925.5143

Email:customerservice@xantrex.com

Direct returns may be performed according to the Xantrex Return Material Authorization Policy described in your product manual. For some products, Xantrex maintains a network of regional Authorized Service Centers. Call Xantrex or check our website to see if your product can be repaired at one of these facilities.

In any warranty claim, dated proof of purchase must accompany the product and the product must not have been disassembled or modified without prior written authorization by Xantrex.

Proof of purchase may be in any one of the following forms:

- The dated purchase receipt from the original purchase of the product at point of sale to the end user, or
- The dated dealer invoice or purchase receipt showing original equipment manufacturer (OEM) status, or
- The dated invoice or purchase receipt showing the product exchanged under warranty

What does this warranty not cover? This Limited Warranty does not cover normal wear and tear of the product or costs related to the removal, installation, or troubleshooting of the customer's electrical systems. This warranty does not apply to and Xantrex will not be responsible for any defect in or damage to:

- a) the product if it has been misused, neglected, improperly installed, physically damaged or altered, either internally or externally, or damaged from improper use or use in an unsuitable environment;
- b) the product if it has been subjected to fire, water, generalized corrosion, biological infestations, or input voltage that creates operating conditions beyond the maximum or minimum limits listed in the Xantrex product specifications including high input voltage from generators and lightning strikes;
- c) the product if repairs have been done to it other than by Xantrex or its Authorized Service Centers (hereafter "ASCs");
- d) the product if it is used as a component part of a product expressly warranted by another manufacturer;
- e) the product if its original identification (trade-mark, serial number) markings have been defaced, altered, or removed.

Disclaimer

Product

THIS LIMITED WARRANTY IS THE SOLE AND EXCLUSIVE WARRANTY PROVIDED BY XANTREX IN CONNECTION WITH YOUR XANTREX PRODUCT AND IS, WHERE PERMITTED BY LAW, IN LIEU OF ALL OTHER WARRANTIES, CONDITIONS, GUARANTEES, REPRESENTATIONS, OBLIGATIONS AND LIABILITIES, EXPRESS OR IMPLIED, STATUTORY OR OTHERWISE IN CONNECTION WITH THE PRODUCT, HOWEVER ARISING (WHETHER BY CONTRACT, TORT, NEGLIGENCE, PRINCIPLES OF MANUFACTURER'S LIABILITY, OPERATION OF LAW, CONDUCT, STATEMENT OR OTHERWISE), INCLUDING WITHOUT RESTRICTION ANY IMPLIED WARRANTY OR CONDITION OF QUALITY, MERCHANTABILITY OR FITNESS FOR A PARTICULAR PURPOSE. ANY IMPLIED WARRANTY OF MERCHANTABILITY OR FITNESS FOR A PARTICULAR PURPOSE TO THE EXTENT REQUIRED UNDER APPLICABLE LAW TO APPLY TO THE PRODUCT SHALL BE LIMITED IN DURATION TO THE PERIOD STIPULATED UNDER THIS LIMITED WARRANTY.

IN NO EVENT WILL XANTREX BE LIABLE FOR ANY SPECIAL, DIRECT, INDIRECT, INCIDENTAL OR CONSEQUENTIAL DAMAGES, LOSSES, COSTS OR EXPENSES HOWEVER ARISING WHETHER IN CONTRACT OR TORT INCLUDING WITHOUT RESTRICTION ANY ECONOMIC LOSSES OF ANY KIND, ANY LOSS OR DAMAGE TO PROPERTY, ANY PERSONAL INJURY, ANY DAMAGE OR INJURY ARISING FROM OR AS A RESULT OF MISUSE OR ABUSE, OR THE INCORRECT INSTALLATION, INTEGRATION OR OPERATION OF THE PRODUCT.

Exclusions

If this product is a consumer product, federal law does not allow an exclusion of implied warranties. To the extent you are entitled to implied warranties under federal law, to the extent permitted by applicable law they are limited to the duration of this Limited Warranty. Some states and provinces do not allow limitations or exclusions on implied warranties or on the duration of an implied warranty or on the limitation or exclusion of incidental or consequential damages, so the above limitation(s) or exclusion(s) may not apply to you. This Limited Warranty gives you specific legal rights. You may have other rights which may vary from state to state or province to province.

Warning: Limitations on use

Please refer to your product user manual for limitations on uses of the product. Specifically, please note that the Xantrex Sun Tie XR inverter is not intended for use in connection with life support systems and Xantrex makes no warranty or representation in connection with any use of the product for such purposes.

Please note that the Xantrex Sun Tie XR inverter is not intended for use as an uninterruptible power supply and Xantrex makes no warranty or representation in connection with any use of the product for such purposes.

Return Material Authorization Policy

Before returning a product directly to Xantrex you must obtain a Return Material Authorization (RMA) number and the correct factory "Ship To" address. Products must also be shipped prepaid. Product shipments will be refused and returned at your expense if they are unauthorized, returned without an RMA number clearly marked on the outside of the shipping box, if they are shipped collect, or if they are shipped to the wrong location.

When you contact Xantrex to obtain service, please have your instruction manual ready for reference and be prepared to supply:

- The serial number of your product
- Information about the installation and use of the unit
- Information about the failure and/or reason for the return
- A copy of your dated proof of purchase

Return Procedure

1. Package the unit safely, preferably using the original box and packing materials. Please ensure that your product is shipped fully insured in the original packaging or equivalent. This warranty will not apply where the product is damaged due to improper packaging.
2. Include the following:
 - The RMA number supplied by Xantrex Technology, Inc. clearly marked on the outside of the box.
 - A return address where the unit can be shipped. Post office boxes are not acceptable.
 - A contact telephone number where you can be reached during work hours.
 - A brief description of the problem.
3. Ship the unit prepaid to the address provided by your Xantrex customer service representative.

If you are returning a product from outside of the USA or Canada

In addition to the above, you **MUST** include return freight funds and are fully responsible for all documents, duties, tariffs, and deposits.

If you are returning a product to a Xantrex Authorized Service Center (ASC) A Xantrex return material authorization (RMA) number is not required. However, you must contact the ASC prior to returning the product or presenting the unit to verify any return procedures that may apply to that particular facility.

Information About Your System

As soon as you open your package, record the following information and be sure to keep your proof of purchase.

- Serial Number _____
- Purchased From _____
- Purchase Date _____

If you need to contact Customer Service, please record the following details before calling. This information will help our representatives give you better service.

- Type of installation _____
 - Length of time Sun Tie XR
has been installed _____
 - Description of problem _____
-

Index

A

AC circuit breaker requirements 2–5

C

combiner board

connecting PV arrays 2–16

DC connection points 2–6

location 2–15

conduit hole locations 2–14

D

DC wiring

connecting 2–15

E

electrical specifications A–2

external cover

locking 3–8

removing 2–12

F

front panel display 1–3, 3–5, 3–6

G

ground clearance required for installation 2–3, 2–10

grounding

ground bar 2–7, 2–16

lightning protection 2–18

long distance 2–20

PV array 2–18

requirements 2–6

roof mount installation 2–19

I

Information About Your System, form B–6

inner breaker cover

removing 2–13

installation

connecting AC wiring 2–16

connecting DC wiring 2–15

grounding 2–18

grounding requirements 2–6

location 2–3

materials required 2–2

mounting 2–9

mounting diagrams 2–11

planning 2–2

PV array requirements 2–7

routing wires 2–3

tools required 2–2

introduction 1–1

inverter status LEDs 4–2

islanding protection 1–3

L

lightning protection 2–18

locking the external cover 3–8

lower panel

removing 4–3

M

mechanical specifications A–3

MPPT

description 1–3

operational window 2–7

O

operation

factors affecting performance 3–10

inverter startup 3–4

messages at startup 3–6

overview 3–1

reassembling the unit 3–8

startup procedure 3–2

P

- parallel configuration 1–3, 2–21
- peak efficiency of Sun Tie XR 1–3
- PV arrays
 - angle of the sun 3–11
 - connecting to combiner board 2–16
 - effect of shade on performance 3–11
 - factory ratings 3–10
 - ground fault protection 2–7, 3–4, A–4
 - grounding 2–18
 - requirements 2–7
 - temperature affecting performance 3–11
 - types of modules 1–3, 2–7, 3–2
 - voltage requirements 2–7

R

- Rain Shield 1–3, 2–3
 - installing 3–8
 - removing 4–3
- remote monitor 1–3
 - installing 2–22
- return material authorization policy B–3
- return procedure B–5
- roof mount installation 2–19

S

- safety instructions vii
- specifications
 - electrical A–2
 - mechanical A–3
 - overview A–1
 - standard features and options A–4
- standard features 1–3
- standard features and options A–4
- standard test condition 3–10
- startup procedure
 - overview 3–2
- status LEDs 1–3, 3–7, 4–2
- Sun Sweep 1–3
- system overview 1–2

T

- temperature
 - affecting PV array performance 3–11
 - range for locating Sun Tie XR 2–3

T

- troubleshooting
 - indicator lights 4–2
 - overview 4–1
 - reference table 4–5

V

- voltmeter
 - measuring AC at startup 3–3
 - measuring DC at startup 3–2

W

- warranty B–2
- wiring
 - AC connections 2–4
 - conduits 2–4
 - connecting AC 2–16
 - DC connections 2–5, 2–15
 - main utility panel to Sun Tie 2–17
 - remote monitor 2–23
 - routing wires 2–3
 - torquing 2–16, 2–17
 - wire sizes 2–4, 2–5

X

- Xantrex
 - return material authorization policy B–3

Xantrex Technology Inc.

360 435 8826 Tel
360 925 5143 Fax
customerservice@xantrex.com
www.xantrex.com