

# Installation, Operating, and Maintenance Instructions

For Use With Positive Pressure Chillers

## SAFETY CONSIDERATIONS

**Positive pressure storage systems are designed to provide safe and reliable service when operated within design specifications. When operating this equipment, use good judgment and safety precautions to avoid damage to equipment and property or injury to personnel. Be sure you understand and follow the procedures and safety precautions contained in this guide.**

### **▲ DANGER**

DO NOT VENT refrigerant relief valves within a building. Outlet from rupture disc or relief valve must be vented outdoors in accordance with the latest edition of ASHRAE 15 (American Society of Heating, Refrigeration, and Air Conditioning Engineers). The accumulation of refrigerant in an enclosed space can displace oxygen and cause asphyxiation.

PROVIDE adequate ventilation in accordance with ASHRAE 15, especially for enclosed and low overhead spaces. Inhalation of high concentrations of vapor is harmful and may cause heart irregularities, unconsciousness, or death. Misuse can be fatal. Vapor is heavier than air and reduces the amount of oxygen available for breathing. Product causes eye and skin irritation. Decomposition products are hazardous.

DO NOT USE OXYGEN to purge lines or to pressurize a machine for any purpose. Oxygen gas reacts violently with oil, grease, and other common substances.

NEVER EXCEED specified test pressures, VERIFY the allowable test pressure by checking the instruction literature and the design pressures on the equipment nameplate.

DO NOT USE air for leak testing. Use only tracer gases and dry nitrogen.

DO NOT VALVE OFF any safety device.

BE SURE that all pressure relief devices are properly installed and functioning before operating any machine.

### **▲ WARNING**

DO NOT WELD OR FLAMECUT any refrigerant line or vessel until all refrigerant (*liquid and vapor*) has been removed from chiller. Traces of vapor should be displaced with dry air or nitrogen and the work area should be well ventilated. *Refrigerant in contact with an open flame produces toxic gases.*

DO NOT USE eyebolts or eyebolt holes to rig machine sections or the entire assembly.

DO NOT work on high-voltage equipment unless you are a qualified electrician.

DO NOT WORK ON electrical components, including control panels, switches, starters, or oil heater until you are sure ALL POWER IS OFF and no residual voltage can leak from capacitors or solid-state components.

LOCK OPEN AND TAG electrical circuits during servicing. IF WORK IS INTERRUPTED, confirm that all circuits are deenergized before resuming work.

DO NOT syphon refrigerant by mouth.

AVOID SPILLING liquid refrigerant on skin or getting it into the eyes. USE SAFETY GOGGLES. Wash any spills from the skin

with soap and water. If any enters the eyes, IMMEDIATELY FLUSH EYES with water and consult a physician.

NEVER APPLY an open flame or live steam to a refrigerant cylinder. Dangerous overpressure can result. When necessary to heat refrigerant, use only warm (110 F [43 C]) water.

DO NOT REUSE disposable (nonreturnable) cylinders or attempt to refill them. It is DANGEROUS AND ILLEGAL. When cylinder is emptied, evacuate remaining gas pressure, loosen the collar and unscrew and discard the valve stem. DO NOT INCINERATE.

CHECK THE REFRIGERANT TYPE before transferring refrigerant to the machine. The introduction of the wrong refrigerant can cause damage or malfunction to this machine.

Operation of this equipment with refrigerants other than those cited herein should comply with ASHRAE 15 (latest edition). Contact Carrier for further information on use of this machine with other refrigerants.

DO NOT ATTEMPT TO REMOVE fittings, covers, etc., while machine is under pressure or while machine is running. Be sure pressure is at 0 psig (0 kPa) before breaking any refrigerant connection.

CAREFULLY INSPECT all relief devices, rupture discs, and other relief devices AT LEAST ONCE A YEAR. If machine operates in a corrosive atmosphere, inspect the devices at more frequent intervals.

DO NOT ATTEMPT TO REPAIR OR RECONDITION any relief device when corrosion or build-up of foreign material (rust, dirt, scale, etc.) is found within the valve body or mechanism. Replace the device.

DO NOT install relief devices in series or backwards.

USE CARE when working near or in line with a compressed spring. Sudden release of the spring can cause it and objects in its path to act as projectiles.

### **▲ CAUTION**

DO NOT STEP on refrigerant lines. Broken lines can whip about and cause personal injury and damage to the machine.

DO NOT climb over a machine. Use platform, catwalk, or staging. Follow safe practices when using ladders.

USE MECHANICAL EQUIPMENT (crane, hoist, etc.) to lift or move inspection covers or other heavy components. Even if components are light, use such equipment when there is a risk of slipping or losing your balance.

BE AWARE that certain automatic start arrangements CAN ENGAGE THE STARTER. Open the disconnect *ahead of* the starter in addition to shutting off the machine or pump.

USE only repair or replacement parts that meet the code requirements of the original equipment.

DOUBLE-CHECK that coupling nut wrenches, dial indicators, or other items have been removed before rotating any shafts.

DO NOT LOOSEN a packing gland nut before checking that the nut has a positive thread engagement.

PERIODICALLY INSPECT all valves, fittings, and piping for corrosion, rust, leaks, or damage.

DO NOT MIX REFRIGERANT from chillers that use different compressor oils. Compressor damage can result.

## CONTENTS

	Page
<b>SAFETY CONSIDERATIONS</b> .....	1
<b>INTRODUCTION</b> .....	2
<b>INSTALLATION</b> .....	2-10
<b>Complete Pre-Installation Checks</b> .....	2
• IDENTIFY UNIT	
• INSPECT SHIPMENT	
<b>Mount the Pumpout Unit</b> .....	3
• MOUNTING ON THE CHILLER	
• FLOOR MOUNTING	
<b>Rig the Storage Tank</b> .....	3
<b>Make Piping Connections</b> .....	7
• INSTALL VENT PIPING TO RELIEF DEVICES	
<b>Make Electrical Connections</b> .....	7
<b>CONTROLS AND COMPONENTS</b> .....	11
<b>Pumpout Unit</b> .....	11
• CONTROLS	
• SAFETY CONTROL SETTINGS	
• COMPRESSOR	
• CONDENSER	
• OIL SEPARATOR	
• SUCTION AND DISCHARGE VALVES	
<b>Storage Tank</b> .....	11
• DRAIN VALVE	
• DUAL RELIEF VALVES	
• PRESSURE GAGE	
• LEVEL GAGE	
<b>OPERATION</b> .....	11-15
<b>Overview</b> .....	11
• REFRIGERANT TRANSFER	
• TRANSFERRING LIQUID REFRIGERANT FROM THE CHILLER COOLER TO THE CHILLER CONDENSER OR PUMPOUT STORAGE TANK	
• TRANSFERRING LIQUID REFRIGERANT FROM THE CHILLER CONDENSER OR PUMPOUT STORAGE TANK TO THE CHILLER COOLER	
• DISTILLING THE REFRIGERANT	
<b>Pumpout and Refrigerant Transfer Procedures</b> .....	12
• OPERATING THE PUMPOUT UNIT	
• TO READ REFRIGERANT PRESSURES	
• POSITIVE PRESSURE CHILLERS WITH STORAGE TANKS	
• CHILLERS WITH ISOLATION VALVES	
• DISTILLING THE REFRIGERANT	
<b>MAINTENANCE</b> .....	15,16
<b>Pumpout Unit</b> .....	15
• PUMPOUT COMPRESSOR OIL CHARGE	
<b>Storage Tank</b> .....	16
<b>Ordering Replacement Parts</b> .....	16
<b>TROUBLESHOOTING</b> .....	16

## INTRODUCTION

The 19XB Positive Pressure Storage (PPS) System has been designed to help owners and operators of positive pressure chillers store refrigerants HCFC-22 and HFC-134a during service and repair work. The 19XB system conserves these refrigerants and prevents the release of excessive amounts of refrigerant into the atmosphere. The proper use of this equipment minimizes the loss of HFCs and HCFCs.

The 19XB PPS system shown in Fig. 1 consists of a pumpout unit mounted on a storage tank. The pumpout unit is offered as a free-standing unit that can be used with chillers that have an existing storage tank or with chillers that have isolation valves that permit built-in refrigerant storage.

The 19XB PPS systems are factory tested and certified to the American Society of Mechanical Engineers (ASME) pressure vessel code. The tanks are constructed of certified steel and are pressure rated at 300 psig (2068 kPa). The PPS storage tank is equipped with dual relief valves for proper venting per ASHRAE 15 (American Society of Heating Refrigeration, and Air Conditioning Engineers) guidelines. An automatic level switch is prewired to the control circuit to ensure proper storage levels.

The 19EA pumpout unit is a complete, hermetic, compact unit that consists of:

- a spring-mounted reciprocating compressor with a direct-drive motor
- a water-cooled refrigerant condenser
- an oil separator
- suction and discharge valves to control refrigerant flow
- prewired safety and control devices.

When referencing refrigerant charges in this manual, the HCFC-22 charge will be listed first and the HFC-134a value will follow in brackets.

## INSTALLATION

### Complete Pre-Installation Checks

**IDENTIFY UNIT** — Identify the assembly number (Table 1) printed on the pumpout unit and storage tank nameplates. Check this information against the job requirements. Fig. 1 shows the PPS system and its major components. Refer to Tables 2 and 3 for physical data.

**INSPECT SHIPMENT** — Inspect unit for damage before removing unit from shipping conveyance. If unit appears damaged, it should be inspected by a shipping inspector before removal. File a claim with the shipping company if shipment is damaged or incomplete. The manufacturer is not responsible for damage incurred during transit.

Check all components. Notify the supplier immediately if any item is missing. To prevent loss or damage, leave all parts in their original package until they are needed.

**Table 1 — Positive Pressure System Assembly Numbers**

POSITIVE PRESSURE SYSTEM ASSEMBLY NUMBER	PUMPOUT UNIT ASSEMBLY NO.	REFRIGERANT	COMPRESSOR MOTOR (V-Ph-Hz)	MAXIMUM RLA	LRA	STORAGE TANK
19XB04280205	19EA42-748	R-22	208-3-60	13.2	63.5	28 cu ft
19XB04280206	19EA44-748	R-22	230-3-60	11.5	57.5	28 cu ft
19XB04280207	19EA46-748	R-22	400/460-3-50/60	5.8	28.8	28 cu ft
19XB04280208	19EA47-748	R-22	575-3-60	4.6	23.0	28 cu ft
19XB04280213	19EA48-748	R-134a	208-3-60	13.2	63.5	28 cu ft
19XB04280214	19EA49-748	R-134a	230-3-60	11.5	57.5	28 cu ft
19XB04280215	19EA51-748	R-134a	400/460-3-50/60	5.8	28.8	28 cu ft
19XB04280216	19EA52-748	R-134a	575-3-60	4.6	23.0	28 cu ft
19XB04280601	19EA42-748	R-22	208-3-60	13.2	63.5	None
19XB04280602	19EA44-748	R-22	230-3-60	11.5	57.5	None
19XB04280603	19EA46-748	R-22	400/460-3-50/60	5.8	28.8	None
19XB04280604	19EA47-748	R-22	575-3-60	4.6	23.0	None
19XB04280605	19EA48-658	R-134a	208-3-60	13.2	63.5	None
19XB04280606	19EA49-658	R-134a	230-3-60	11.5	57.5	None
19XB04280607	19EA51-658	R-134a	400/460-3-50/60	5.8	28.8	None
19XB04280608	19EA52-658	R-134a	575-3-60	4.6	23.0	None
19XB04520205	19EA42-748	R-22	208-3-60	13.2	63.5	52 cu ft
19XB04520206	19EA44-748	R-22	230-3-60	11.5	57.5	52 cu ft
19XB04520207	19EA46-748	R-22	400/460-3-50/60	5.8	28.8	52 cu ft
19XB04520208	19EA47-748	R-22	575-3-60	4.6	23.0	52 cu ft
19XB04520213	19EA48-748	R-134a	208-3-60	13.2	63.5	52 cu ft
19XB04520214	19EA49-748	R-134a	230-3-60	11.5	57.5	52 cu ft
19XB04520215	19EA51-748	R-134a	400/460-3-50/60	5.8	28.8	52 cu ft
19XB04520216	19EA52-748	R-134a	575-3-60	4.6	23.0	52 cu ft

**LEGEND**

**LRA** — Locked Rotor Amps  
**RLA** — Rated Load Amps

**NOTES:**

1. All storage vessels are 300 psig (2068 kPa) designs per the ASME (American Society of Mechanical Engineers) Boiler Pressure Vessel Code, Section VIII Division 1.
2. All units above are shipped with a 15 psig (103 kPa) nitrogen charge.
3. Nominal horsepower for all pumpout units is 3.0.

**Mount the Pumpout Unit** — The pumpout unit, if purchased separately, may be mounted directly on the chiller or it may be floor mounted.

**MOUNTING ON THE CHILLER** — See instructions provided with the chiller for mounting the pumpout unit. A typical chiller mount is shown in Fig. 2.

**FLOOR MOUNTING** — Select a ventilated and accessible area, free of traffic or other hazards. Remove and discard the 4 angle supports at the base of the pumpout unit and bolt the unit to the floor through the 4<sup>7</sup>/<sub>16</sub> in. holes at the base of the pumpout unit. Special isolation is unnecessary. Contact surface and dimensions for the pumpout unit are given in Fig. 3.

**Rig the Storage Tank** — The complete 19XB system can be rigged as a single assembly. See the rigging instructions on the label attached to the assembly. Also refer to the rigging guide (Fig. 4), physical data in Tables 2 and 3, and contact surface and dimensions for the complete system in Fig. 5. *Lift the assembly only from the 4 points indicated in the rigging guide.* Each rigging cable must be capable of supporting the entire weight of the assembly.

**⚠ WARNING**

Lifting the assembly from points other than those specified may result in serious damage to the assembly and personal injury. Rigging equipment and procedures must be adequate for assembly. See Tables 2 and 3 for weights. NOTE: These weights are broken down into pumpout unit and storage tank weights. For the complete assembly weight, add all components together.

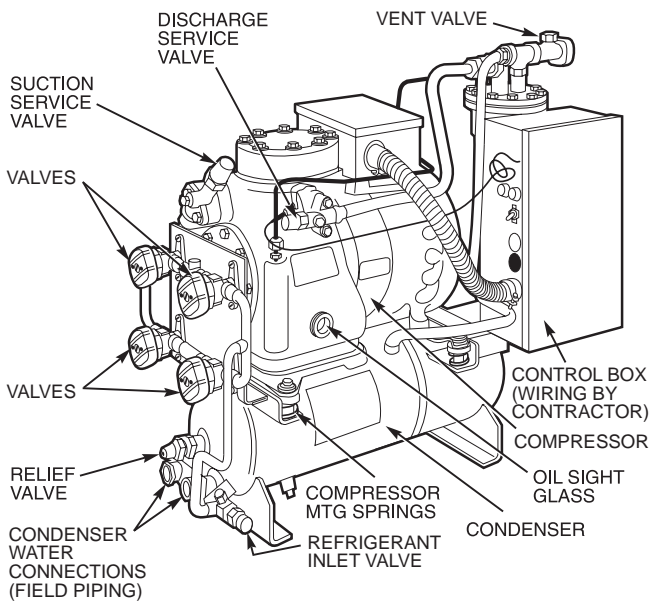

19EA PUMPOUT UNIT

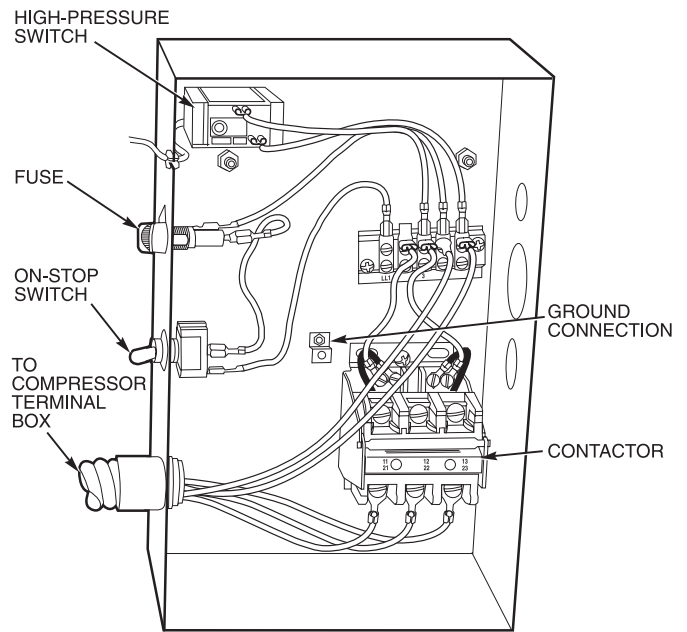

19EA CONTROL BOX (INTERIOR)

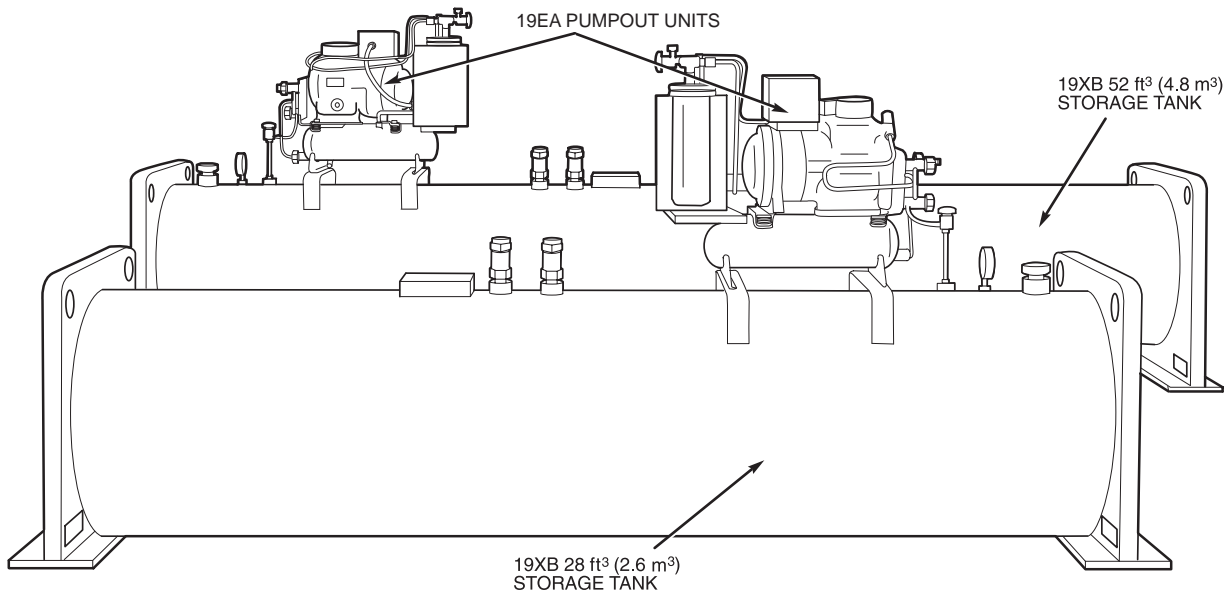
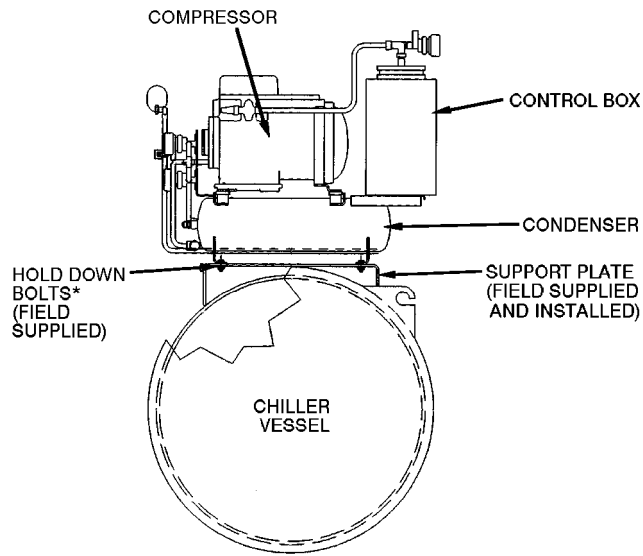

Fig. 1 — 19XB Positive Pressure Storage System



\* $\frac{3}{8}$ -16 bolts x 1-in. lg; 4 required.

Fig. 2 — 19EA Pumpout Unit: Typical Chiller Mount

ELECTRICAL CONNECTION OPTION LIST

TRADE SIZE	QTY	LOCATION
1/2"	1	TOP
3/4"	1	BOTTOM
1"	1	MIDDLE
1 1/4"	1	MIDDLE

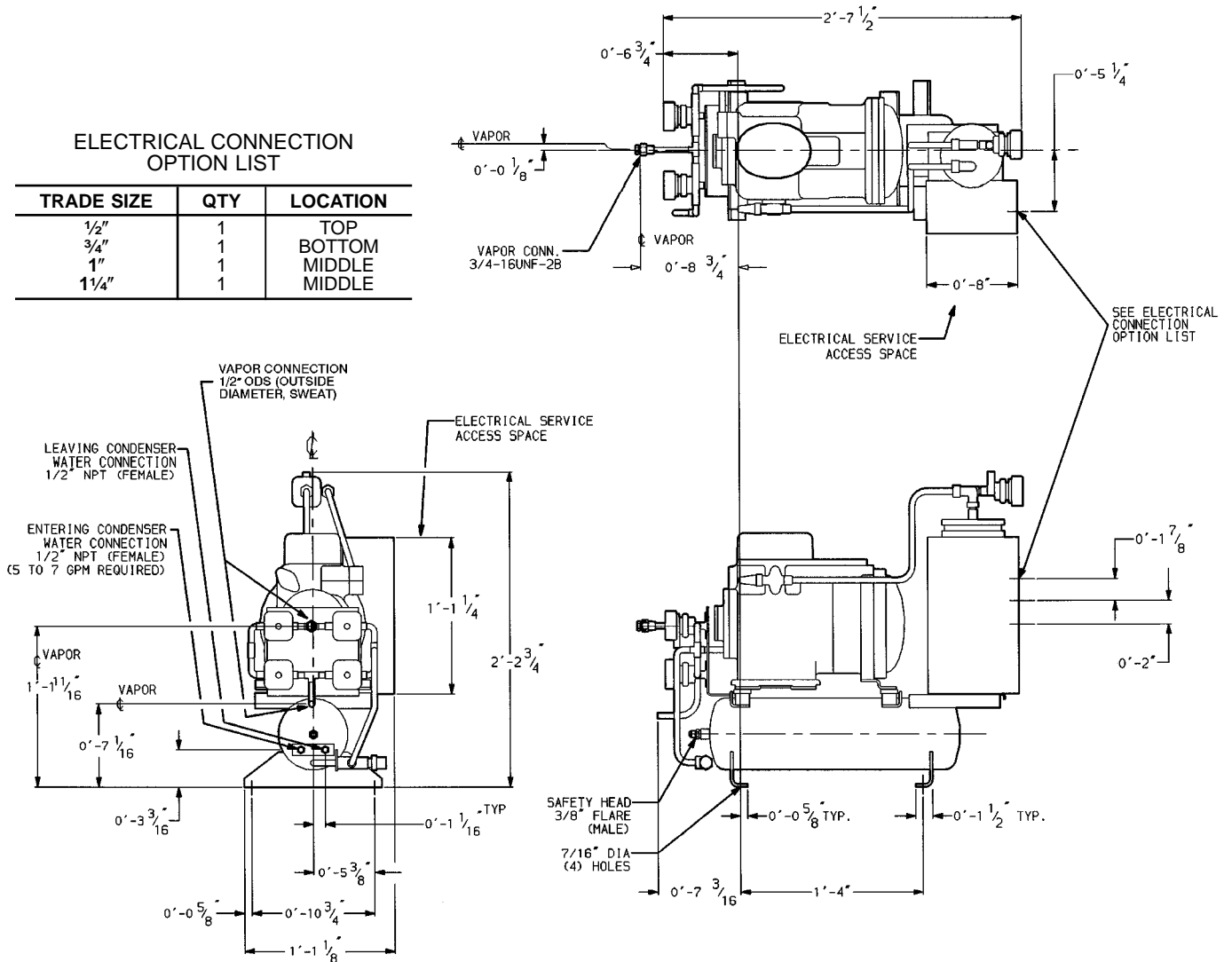
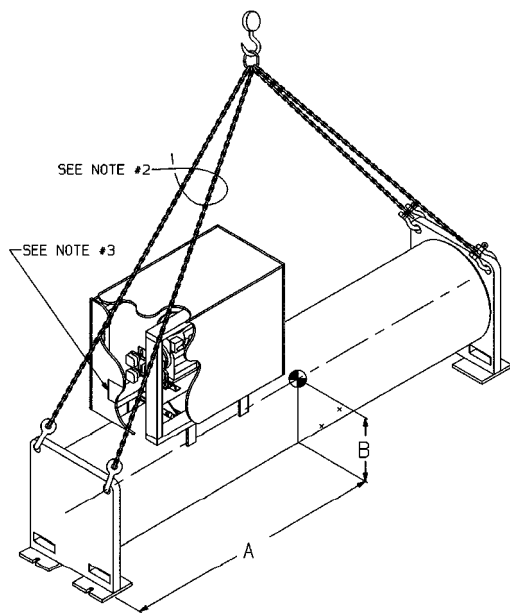

Fig. 3 — Pumpout Unit Contact Surfaces and Dimensions



- NOTES:
1. Each chain must be capable of supporting the entire weight of the machine.
  2. Minimum chain length:  
28 ft<sup>3</sup> tank — 10'-0"  
52 ft<sup>3</sup> tank — 15'-6"
  3. Total weight equals empty weight from chart and charge weight given on label.

STORAGE TANK SIZE	CENTER OF GRAVITY APPROX. DIM. — ft-in. (mm)		EMPTY WEIGHT LB (Kg)
	A	B	
28 Ft <sup>3</sup>	4- 5¼ (1353)	1-7⅞ (505)	2380 (1080)
52 Ft <sup>3</sup>	6-10⅞ (2086)	1-8¾ (527)	3460 (1569)

Fig. 4 — Rigging Guide

Table 2 — Physical Data  
19EA Pumpout Unit

		ENGLISH	(SI)
Pumpout Unit Weight*	lb (kg)	210	(95)
Pumpout Condenser Water Flow Rate	gpm (L/s)	5 to 7	(.32 to .44)
Pumpout Condenser Water Pressure Drop	psig (kPa)	6 to 10.7	(41.4 to 73.8)
Maximum Entering Condenser Water Temperature	F (C)	85	(29)
Maximum Leaving Condenser Water Temperature	F (C)	100	(37)
Condenser Relief Valve (Fusible Plug)	psig (kPa)	385	(2655)
Condenser Pressure Rating			
Refrigerant Side	psig (kPa)	385	(2655)
Waterside	psig (kPa)	150	(1034)
Compressor Rating 1750 rpm (29 r/s) Reciprocating	cfm (L/s)	8.7	(.25)
Valves (4-Valve Manifold, Copper with Brass Turn Knob Valves)	in. OD	½	½

\*The pumpout unit weight includes the compressor/condenser, control box, and the oil separator.

NOTES:

1. The motor is hermetic with thermal protection.
2. The control box is mounted and wired with a fuse on/off switch according to NEMA 1 (National Electrical Manufacturing Association).
3. The starter contactor is located in the control box. The overloads on the motor are wired and the disconnect switch is supplied by the customer.
4. The condenser tube is copper.

**Table 3 — 19XB Storage Tank Rated Dry Weight and Refrigerant Capacity**

**English**

SIZE CODE	TANK OD (in.)	DRY WEIGHT* (lb)	MAXIMUM REFRIGERANT CAPACITY (lb)			
			ASHRAE/ANSI 15		UL 1963	
			R-22	R-134a	R-22	R-134a
0428	24.00	2380	1842	1860	1704	1716
0452	27.25	3460	3527	3563	3264	3286

**SI**

SIZE CODE	TANK OD (mm)	DRY WEIGHT* (kg)	MAXIMUM REFRIGERANT CAPACITY (kg)			
			ASHRAE/ANSI 15		UL 1963	
			R-22	R-134a	R-22	R-134a
0428	610	1080	836	844	773	778
0452	592	1569	1600	1616	1481	1491

**LEGEND**

- ANSI** — American National Standards Institute
- ASHRAE** — American Society of Heating, Refrigeration, and Air Conditioning Engineers
- UL** — Underwriters' Laboratories

\*The above dry weight includes the pumpout unit weight of 210 lbs (95 kg).

**Make Piping Connections** — Figure 6 represents typical pumpout unit/chiller piping connections. Standard connections for 1/2-in. OD copper tubing are provided. Install the field-supplied FPT tee with pipe plug in the piping as shown in Fig. 6. This tee is used for refrigerant charging.

NOTE: If any field piping runs exceed 50 ft in length, use 7/8-in. OD copper tubing to minimize pressure drop.

Pumpout unit water piping connections are shown in Fig. 6. Both connections are 1/2-in. NPT (female). A shutoff valve should be installed in the water line. Provide a means for blowing water from the condenser coil at winter shutdown to prevent freeze-up damage. Refer to the Job Data for water piping particulars.

**INSTALL VENT PIPING TO RELIEF DEVICES** — The pumpout storage tank is factory-equipped with relief devices. Refer to Fig. 5 and Table 2 for size and location of the relief devices. Vent the relief devices to the outdoors in accordance with ANSI/ASHRAE 15 Safety Code (latest edition) for Mechanical Refrigeration and all other applicable codes. Relief devices are set to relieve at 300 psig (2068 kPa).

1. If relief devices are manifolded, the cross-sectional area of the relief pipe must at least equal the sum of the areas required for individual relief pipes.
2. Provide a pipe plug near outlet side of each relief device for leak testing. Provide pipe fittings that allow vent piping to be disconnected periodically for inspection of valve mechanism.
3. Piping to relief devices must not apply stress to the device. Adequately support piping. A length of flexible tubing or piping near the device is essential on spring-isolated machines.
4. Cover the outdoor vent with a rain cap and place a condensation drain at the low point in the vent piping to prevent water build-up on the atmospheric side of the relief device.

**Make Electrical Connections** — See nameplate on compressor of pumpout unit and Table 1 for motor electrical data. Wire unit according to the diagram inside the control box.

Fig. 7 is the wiring schematic for a complete system that includes the 19XB storage tank and the pumpout unit. Fig. 8 is the wiring schematic for the pumpout unit. Use this schematic for installations that do not include an auxiliary pumpout storage tank.

NOTE: Use copper conductors only.

**▲ DANGER**

Refrigerant discharged into confined spaces can displace oxygen and cause asphyxiation.

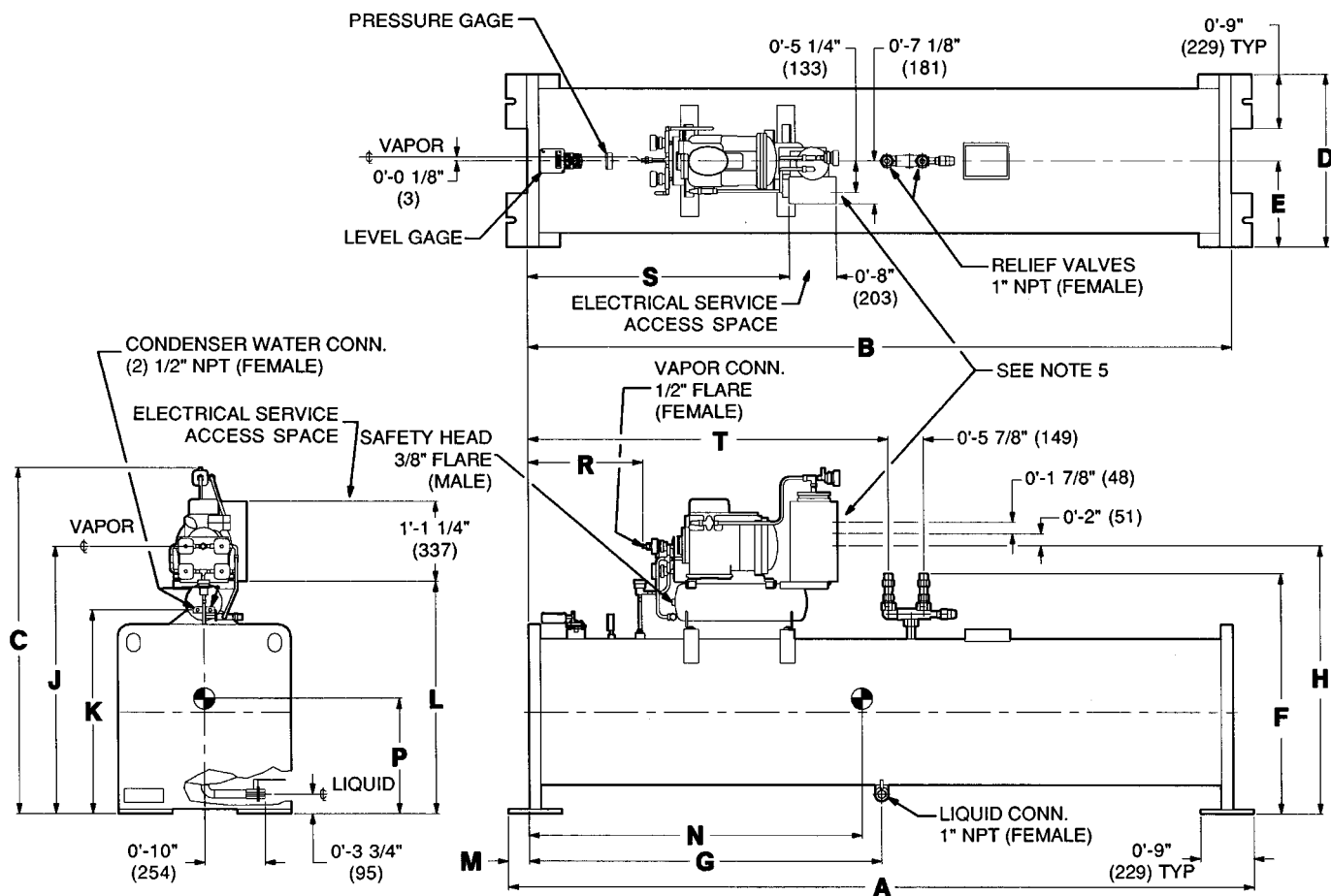

DIMENSIONS  
ENGLISH (ft-in.)

TANK SIZE	A	B	C	D	E	F	G	H	J	K	L	M	N	P	R	S	T
0428	10- 5	9-10	4-9	2-4 <sup>3</sup> / <sub>4</sub>	1-2 <sup>3</sup> / <sub>8</sub>	3-1 <sup>3</sup> / <sub>16</sub>	4-11	3-8 <sup>1</sup> / <sub>8</sub>	3- 8	2-9 <sup>7</sup> / <sub>16</sub>	3-2	0-3 <sup>1</sup> / <sub>2</sub>	4-8 <sup>3</sup> / <sub>4</sub>	1-7 <sup>7</sup> / <sub>8</sub>	1-7 <sup>5</sup> / <sub>16</sub>	3-7 <sup>3</sup> / <sub>4</sub>	5-0 <sup>1</sup> / <sub>4</sub>
0452	14-11 <sup>1</sup> / <sub>4</sub>	14- 4 <sup>1</sup> / <sub>2</sub>	5-0 <sup>7</sup> / <sub>8</sub>	2-8 <sup>1</sup> / <sub>2</sub>	1-4 <sup>1</sup> / <sub>4</sub>	3-4 <sup>7</sup> / <sub>16</sub>	7- 2 <sup>1</sup> / <sub>4</sub>	4-0	3-11 <sup>7</sup> / <sub>8</sub>	3-1 <sup>5</sup> / <sub>16</sub>	3-5 <sup>7</sup> / <sub>8</sub>	0-3 <sup>3</sup> / <sub>8</sub>	7-1 <sup>1</sup> / <sub>2</sub>	1-8 <sup>3</sup> / <sub>4</sub>	1-7 <sup>9</sup> / <sub>16</sub>	3-8	5-0 <sup>1</sup> / <sub>2</sub>

SI (mm)

TANK SIZE	A	B	C	D	E	F	G	H	J	K	L	M	N	P	R	S	T
0428	3175	2997	1448	730	365	945	1499	1121	1118	849	965	89	1442	505	491	1111	1530
0452	4553	4382	1546	826	413	1027	2191	1219	1216	948	1064	86	2172	528	497	1118	1537

NOTES:

1.  Denotes center of gravity.
2. Dimensions in ( ) are in millimeters.
3. The weights and center of gravity values given are for an empty storage tank.
4. For additional information on the pumpout unit, see certified drawings.
5. The available conduit knockout sizes are:

TRADE SIZE	QTY	LOCATION
1/2"	1	top
3/4"	1	bottom
1"	1	middle
1 1/4"	1	middle

Fig. 5 — PPS Contact Surface and Dimensions



## CHILLERS WITHOUT ISOLATION VALVES

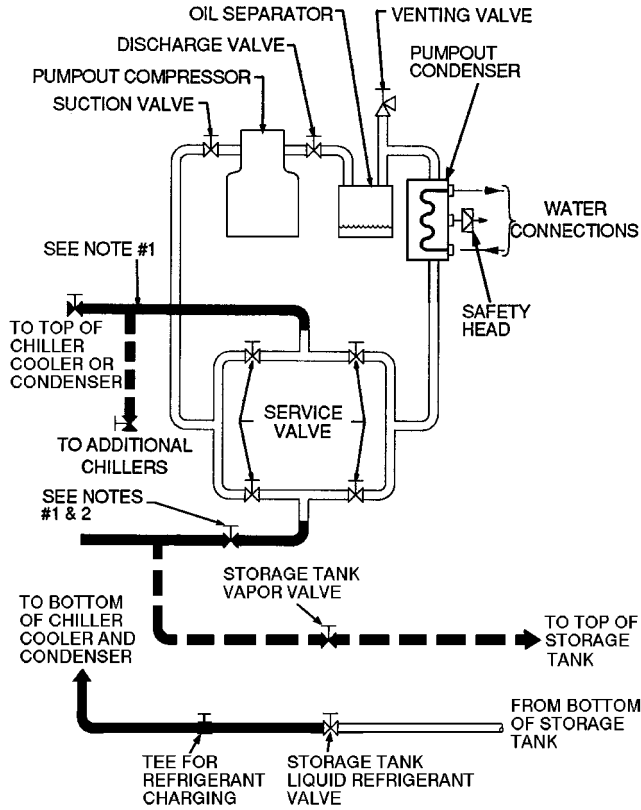

## CHILLERS WITH ISOLATION VALVES (WITH OR WITHOUT PUMPOUT STORAGE TANKS)

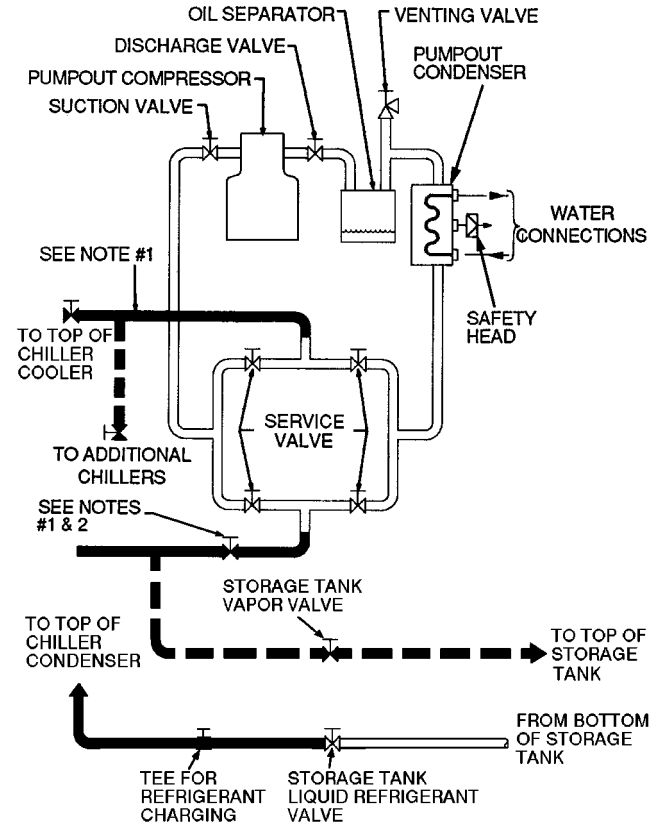

### GENERAL PIPING CONNECTION SIZES

CONNECTION	SIZE (in.)
Refrigerant Transfer Connections	1/2 ODS (female)
Condenser Water Cooling Connectors	1/2 NPT (female)
Safety Relief Head Pumpdown Condenser	3/8 Flare (male)

ODS — Outside Diameter, Sweat

### LEGEND

	Factory-Supplied Tubing
	Field-Supplied Tubing
	Field-Supplied Tubing (Multiple Chillers)
	Service Valve (Factory Supplied)
	Service Valve (Field Supplied)

### NOTES:

1. The field-supplied tubing is to be 1/2-in. OD tubing (min.) and must be arranged and supported to avoid stresses on the equipment, transmission of vibrations, and interference with routine access during the reading, adjusting, and servicing of the equipment. If the distance from the chiller to the pumpout unit is over 50 ft, then 7/8-in. OD tubing (min.) must be used. Provisions should be made for adjustment in each plane of the tubing and for both periodic and major servicing of the equipment. Special care must be taken so that the safety head does not experience tubing strain. Vent the safety head per ASHRAE 15 (American Society of Heating, Refrigeration, and Air Conditioning Engineers), latest revision.
2. The tubing and valve from the storage tank to the pumpout compressor is factory supplied when the unit is factory mounted.

Fig. 6 — Typical Pumpout Unit/Chiller Connection Schematic

**Table 4 — Relief Devices**

STORAGE TANK SIZE	RELIEF VALVE OUTLET SIZE	QUANTITY	REQUIRED FACTOR	
			lb air min	Kg air min
28	1 in. NPT Female Connector	2	31.4	14.2
52	1 in. NPT Female Connector	2	52.3	23.7

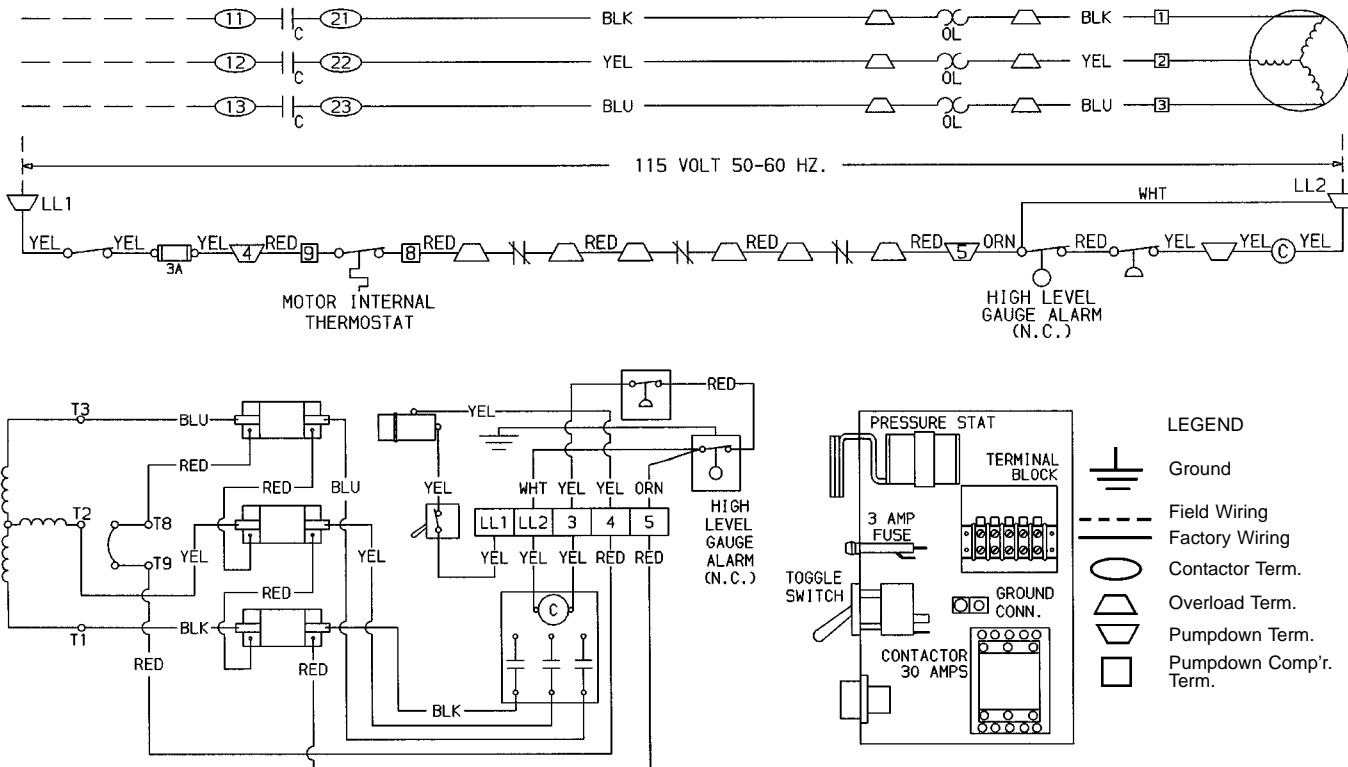

**Fig. 7 — 19XB Pumpout System Wiring Schematic**

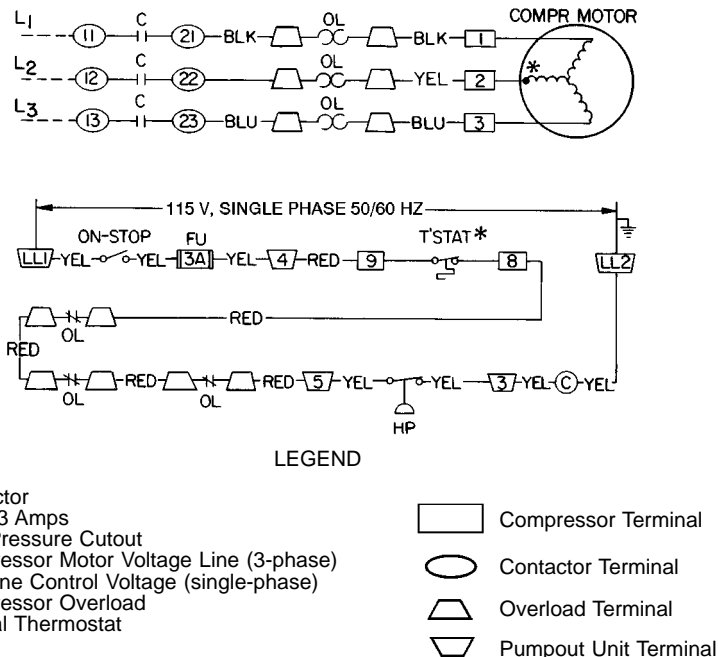

\*Bimetal thermal protector imbedded in motor winding.

**Fig. 8 — Pumpout Unit Wiring Schematic**

## CONTROLS AND COMPONENTS

Figure 1 shows the major components of the PPS system.

**Pumpout Unit** — The pumpout unit consists of a spring-mounted direct motor-driven reciprocating compressor, a water-cooled refrigerant condenser, an oil separator, suction and discharge valves to control refrigerant flow, and prewired safety and control devices. The pumpout unit comes equipped with a 4-way transfer valve manifold to interconnect both liquid and vapor transfer and to pressurize the chiller during transfer of refrigerant from chiller to storage tank.

**CONTROLS** — The pumpout unit has the following controls: an on/off switch, a 3-amp fuse, compressor overloads, an internal thermostat, a compressor contactor, and a refrigerant high pressure cutout.

**SAFETY CONTROL SETTINGS** — The pumpout unit high-pressure switch (Fig. 1) is set to open at the settings listed in Table 5. The switch setting is checked by operating the pumpout condenser and slowly throttling the pumpout condenser water.

**Table 5 — High Condition Pressure Switch Settings**

English		
REFRIGERANT	HIGH-PRESSURE SWITCH	
	Cutout	CutIn
R-134a	161 ± 5 psig	+ 0 130 – 5 psig
R-22	220 ± 5 psig	+ 0 185 – 5 psig
SI		
REFRIGERANT	HIGH-PRESSURE SWITCH	
	Cutout	Cut-In
R-134a	1110 ± 34 kPa	+ 0 896 – 34 kPa
R-22	1517 ± 34 kPa	+ 0 1276 – 34 kPa

**NOTES:**

1. R-22 units use high-pressure cutout switch HK01UA181.
2. R-134a units use high-pressure cutout switch HK01UA187.

**COMPRESSOR** — The pumpout compressor assembly has a positive displacement of 1750 rpm (29 r/s) and 8.7 cfm (0.004 m<sup>3</sup>/s). It comes equipped with thermal protection on the motor and an in-line oil separator.

**CONDENSER** — The water-cooled condenser is fully ASME constructed. During transfer, it condenses refrigerant vapor to liquid. The condenser transfer tank safety relief valves comply with ASHRAE 15 standards.

**OIL SEPARATOR** — The pumpout unit includes an in-line oil separator to remove oil that becomes mixed with refrigerant and returns the oil to the compressor.

**SUCTION AND DISCHARGE VALVES** — The pumpout unit comes with a 4-way transfer valve manifold to interconnect both liquid and vapor transfer and to pressurize the chiller during transfer of refrigerant from chiller to storage tank or from one chiller vessel to another.

**Storage Tank** — The storage tank is rated for positive pressure refrigerants under ASME Section VIII pressure vessel codes with a minimum of 300 psig (2068 kPa) rating. The tank components include:

**DRAIN VALVE** — Located at its lowest point of drain with a minimum of 1 in. NPT.

**DUAL RELIEF VALVES** — Two relief valves and a 3-way shut-off valve.

**PRESSURE GAGE** — A 30 in.-0-400 psig (101-0-2760 kPa) compound pressure gage.

**LEVEL GAGE** — Liquid level gage (magnetically coupled dial type) with electronic shut-off at 90% liquid capacity.

### ⚠ WARNING

During transfer of refrigerant into and out of the pumpout storage tank, carefully monitor the storage tank level gage. Do not fill the tank more than 90% of capacity to allow for refrigerant expansion. Overfilling may result in damage to the tank and personal injury. For maximum refrigerant capacity, refer to Table 2.

## OPERATION

**Overview** — Transferring refrigerant from one vessel to another is accomplished by using either gravity or pressure differential. A difference in elevation between 2 vessels results in a gravity flow of liquid; a difference in pressure forces the liquid from one vessel to the other. The latter method requires lowering the pressure in one vessel. If there is liquid in that vessel, its temperature must be lowered, and the pressure in the other vessel must be simultaneously increased.

Under most circumstances, creating the pressure differential is not a difficult process. Some applications, such as ice storage, outdoor installations, or installations with high temperature differentials between the storage tank and the chiller may require additional consideration. In some instances, it may be necessary to add auxiliary heat to one of the vessels or to insulate the storage tank at job sites where high ambient temperature or sun load make it difficult to reduce the temperature and pressure in the tank. Outdoor installations must have a roof or cover over the storage tank to ensure that the pressure in the tank does not exceed the chiller relief pressure setting.

**REFRIGERANT TRANSFER** — When refrigerant is being evacuated from the chiller cooler or condenser vessels, any liquid refrigerant left in a vessel will flash off, lowering the temperature in that vessel enough to freeze the fluid (usually water) flowing through the cooler or condenser tubes. This event, called tube freeze-up, can cause extensive damage to the chiller; therefore, all liquid refrigerant must be removed from a vessel before evacuation of refrigerant vapor is started. If all the liquid cannot be removed, then the cooler water and condenser water pumps must be operated throughout the process of evacuating refrigerant vapor to keep fluid moving through the cooler and condenser tubes.

**TRANSFERRING LIQUID REFRIGERANT FROM THE CHILLER COOLER TO THE CHILLER CONDENSER OR PUMPOUT STORAGE TANK** — Chiller and pumpout unit valves are set to permit the pumpout compressor to discharge refrigerant vapor into the cooler vessel, lowering pressure in the condenser vessel/storage tank. The pressure differential forces liquid from the cooler vessel into the condenser vessel/storage tank. After all the liquid is transferred, the refrigerant vapor remaining in the cooler vessel can be drawn off by reducing pressure in the chiller and discharging the vapor through the pumpout unit condenser into the condenser vessel/storage tank.

**TRANSFERRING LIQUID REFRIGERANT FROM THE CHILLER CONDENSER OR PUMPOUT STORAGE TANK TO THE CHILLER COOLER** — Chiller and pumpout unit valves are set to increase pressure in the chiller condenser vessel/storage tank and to reduce pressure in the cooler vessel. Pressure in the cooler vessel is lowered to correspond to a saturated refrigerant liquid temperature 2 F (1.1 C) above the freezing temperature of the liquid circulating through the chiller cooler/condenser tubes (34 F [1.1 C] for water). The valves are set so that the pressure in the cooler vessel is lower than that of the condenser vessel/storage tank, forcing the liquid into the cooler vessel.

NOTE: During this operation, maintain water circulation through the chiller cooler and condenser vessels to prevent tube freeze-up.

**DISTILLING THE REFRIGERANT** — Refrigerant vapor is transferred from the chiller cooler vessel or pumpout storage tank through the pumpout condenser, condensed to a liquid, and pumped to the chiller condenser vessel. During this operation, water circulation must be maintained in the pumpout condenser. Refrigerant impurities left in the chiller cooler vessel or storage tank are then drained off. This operation can take from 4 to 14 hours, depending on the type and amount of refrigerant being distilled.

The Pumpout and Refrigerant Transfer Procedures section gives step-by-step instructions on performing these operations.

### Pumpout and Refrigerant Transfer Procedures

— Three possibilities are available:

1. If there are no isolation valves on the chiller, a complete pumpout system with a pumpout storage tank and pumpout unit is needed.
2. Whether or not isolation valves are available on the chiller, the refrigerant can be pumped to and isolated in a pumpout storage tank by using the pumpout unit.
3. If isolation valves are available on the chiller, the refrigerant can be pumped to either the cooler vessel or the condenser vessel using the pumpout unit.

The following procedures describe how to transfer refrigerant from one vessel to another and how to evacuate the chiller.

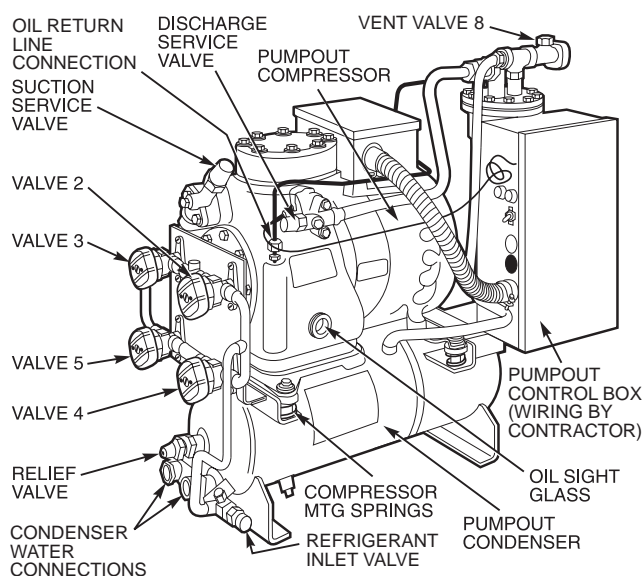

**Fig. 9 — Pumpout Unit**

2. Attach a 30 in.-0-400 psi (101-0-2760 kPa) gage to the storage tank to determine its pressure.

**POSITIVE PRESSURE CHILLERS WITH STORAGE TANKS** — In the Valve/Condition tables that accompany these instructions, the letter "C" indicates a closed valve. Figures 9 and 10 show the locations of the valves.

**⚠ WARNING**

Always run chiller cooler and condenser water pumps and always charge or transfer refrigerant as a gas when chiller vessel pressure is less than 60 psig (414 kPa) [30 psig (207 kPa)]. Below these pressures, liquid refrigerant flashes into gas, resulting in extremely low temperatures in the cooler/condenser tubes and possibly causing tube freeze-up.

#### Transfer Refrigerant from Pumpout Storage Tank to Chiller:

**⚠ WARNING**

During transfer of refrigerant into and out of the 19XB storage tank, carefully monitor the storage tank level gage. Do not fill the tank more than 90% of capacity to allow for refrigerant expansion. Overfilling may result in damage to the tank and personal injury.

1. Equalize refrigerant pressure.
  - a. Turn on chiller water pumps and monitor chiller pressures.
  - b. Close pumpout and storage tank valves 2, 4, 5, 8, and 10, and close refrigerant charging valve 7; open chiller isolation valve 11 and any other chiller isolation valves, if present.
  - c. Open pumpout and storage tank valves 3 and 6; open chiller valves 1a and 1b.

VALVE	1a	1b	2	3	4	5	6	7	8	10	11
CONDITION			C		C	C		C	C	C	

- d. Gradually crack open valve 5 to increase chiller pressure to 60 psig (414 kPa), [ 30 psig (207 kPa)]. Slowly feed refrigerant to prevent freeze-up.

**⚠ CAUTION**

Do not mix refrigerants from chillers that use different compressor oils. Compressor damage can result. For example, the compressor oil in a 23XL chiller that uses HCFC-22 refrigerant can cause severe lubrication problems in a 19XL chiller that uses HCFC-22 refrigerant.

#### OPERATING THE PUMPOUT UNIT

1. Be sure that the suction and the discharge service valves on the pumpout compressor (Fig. 9) are open (backseated) during operation. Rotate the valve stem fully counterclockwise to open. Frontseating the valve closes the refrigerant line and opens the gage port to compressor pressure.
2. Make sure that the pumpout compressor holddown bolts (Fig. 2) have been loosened to allow free spring travel.

**⚠ CAUTION**

Transfer, addition, or removal of refrigerant in spring-isolated chillers may place severe stress on external piping if springs on the chiller have not been blocked in both up and down directions.

3. Open the refrigerant inlet valve (Fig. 9) on the pumpout compressor.
4. Oil should be visible in the pumpout compressor sight glass under all operating conditions and during shutdown. If oil is low, add oil as described in the Maintenance section.

**TO READ REFRIGERANT PRESSURES** — During pumpout or leak testing:

1. Refer to the display on the chiller control center to determine refrigerant-side pressures and low (soft) vacuum. Use a quality vacuum indicator or manometer to measure evacuation and dehydration and to ensure the desired range and accuracy.

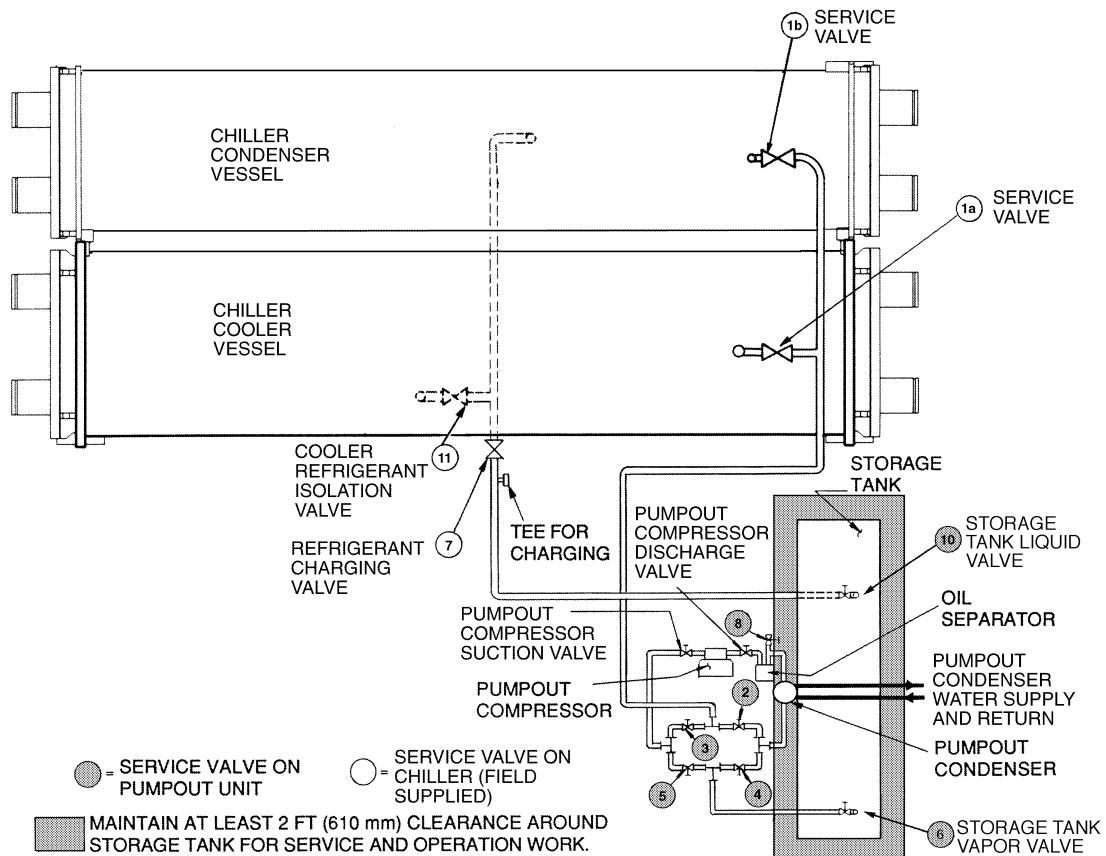

**Fig. 10 — Valve Locations for 19XB Pumpout Unit With 19XB Storage Tank**

- e. Open valve 5 fully after the chiller pressure rises above the freezing point of the refrigerant. Let the storage tank and chiller pressure equalize. Open refrigerant charging valve 7 and storage tank charging valve 10 to let liquid refrigerant drain into the chiller.

VALVE	1a	1b	2	3	4	5	6	7	8	10	11
CONDITION			C		C				C		

- 2. Transfer remaining refrigerant.
  - a. Close valve 5 and open valve 4.

VALVE	1a	1b	2	3	4	5	6	7	8	10	11
CONDITION			C			C			C		

- b. Turn off the pumpout condenser water, and turn on the pumpout compressor to push liquid refrigerant out of the storage tank. Monitor the storage tank level until the tank is empty.
- c. Close refrigerant charging valves 7 and 10.
- d. Turn off the pumpout compressor.
- e. Turn off the chiller water pumps.
- f. Close valves 3 and 4.
- g. Open valves 2 and 5.

VALVE	1a	1b	2	3	4	5	6	7	8	10	11
CONDITION				C	C			C	C	C	

- h. Turn on pumpout condenser water.
- i. Run the pumpout compressor until the storage tank pressure reaches 5 psig (34 kPa), 18 in. Hg (41 kPa absolute).
- j. Turn off the pumpout compressor.

- k. Close valves 1a, 1b, 2, 5, and 6.

VALVE	1a	1b	2	3	4	5	6	7	8	10	11
CONDITION	C	C	C	C	C	C	C	C	C	C	

- l. Turn off pumpout condenser water.

Transfer the Refrigerant from Chiller to Pumpout Storage Tank.

- 1. Equalize refrigerant pressure.

- a. Valve positions:

VALVE	1a	1b	2	3	4	5	6	7	8	10	11
CONDITION			C		C	C		C	C	C	

- b. Slowly open valve 5 and refrigerant charging valves 7 and 10 to allow liquid refrigerant to drain by gravity into the storage tank.

VALVE	1a	1b	2	3	4	5	6	7	8	10	11
CONDITION			C		C				C		

- 2. Transfer the remaining liquid.

- a. Turn off pumpout condenser water. Place valves in the following positions:

VALVE	1a	1b	2	3	4	5	6	7	8	10	11
CONDITION				C	C				C		

- b. Run the pumpout compressor for approximately 30 minutes, then close valve 7 and 10.

VALVE	1a	1b	2	3	4	5	6	7	8	10	11
CONDITION				C	C			C	C	C	

- c. Turn off the pumpout compressor.

3. Remove any remaining refrigerant.
  - a. Turn on chiller water pumps.
  - b. Turn on pumpout condenser water.
  - c. Place valves in the following positions:

VALVE	1a	1b	2	3	4	5	6	7	8	10	11
CONDITION			C			C		C	C	C	

- d. Run the pumpout compressor until the chiller pressure reaches 60 psig (414 kPa), [30 psig (207 kPa)]; then, shut off the pumpout compressor. Warm chiller condenser water will boil off any entrapped liquid refrigerant and chiller pressure will rise.
- e. When chiller pressure rises to 70 psig (483 kPa), [40 psig (276 kPa)]; turn on the pumpout compressor until the pressure again reaches 60 psig (414 kPa) [30 psig (207 kPa)]; then, turn off the pumpout compressor. Repeat this process until the chiller pressure no longer rises; then, turn on the pumpout compressor and pump out until the chiller pressure reaches 18 in. Hg (41 kPa absolute).
- f. Close valves 1a, 1b, 3, 4, and 6.

VALVE	1a	1b	2	3	4	5	6	7	8	10	11
CONDITION	C	C	C	C	C	C	C	C	C	C	

- g. Turn off the pumpout condenser water.

4. Establish vacuum for service. To conserve refrigerant, operate the pumpout compressor as described in Step 3e until the chiller pressure is reduced to 18 in. Hg (41 kPa absolute).

**CHILLERS WITH ISOLATION VALVES** — The valves referred to in the following instructions are shown in Fig. 9 and 11. Valve 7 remains closed.

Transfer All Refrigerant to Chiller Condenser Vessel:

1. Push refrigerant into chiller condenser vessel.
  - a. Turn on the chiller water pumps and monitor the chiller pressure.
  - b. Valve positions:

VALVE	1a	1b	2	3	4	5	8	11
CONDITION				C	C		C	

- c. Equalize the refrigerant in the chiller cooler and condenser.
- d. Turn off chiller water pumps and pumpout condenser water supply.
- e. Turn on pumpout compressor to push liquid out of the chiller cooler vessel.
- f. When all liquid has been pushed into the chiller condenser vessel, close the cooler refrigerant isolation valve (11).
- g. Turn on the chiller water pumps.
- h. Turn off the pumpout compressor.
2. Evacuate gas from chiller cooler vessel.
  - a. Close pumpout valves 2 and 5; open valves 3 and 4.

VALVE	1a	1b	2	3	4	5	8	11
CONDITION			C			C	C	C

- b. Turn on pumpout condenser water.
- c. Run pumpout compressor until the chiller cooler vessel pressure reaches 18 in. Hg vac (41 kPa absolute). Monitor pressures on the chiller control panel and on refrigerant gages.

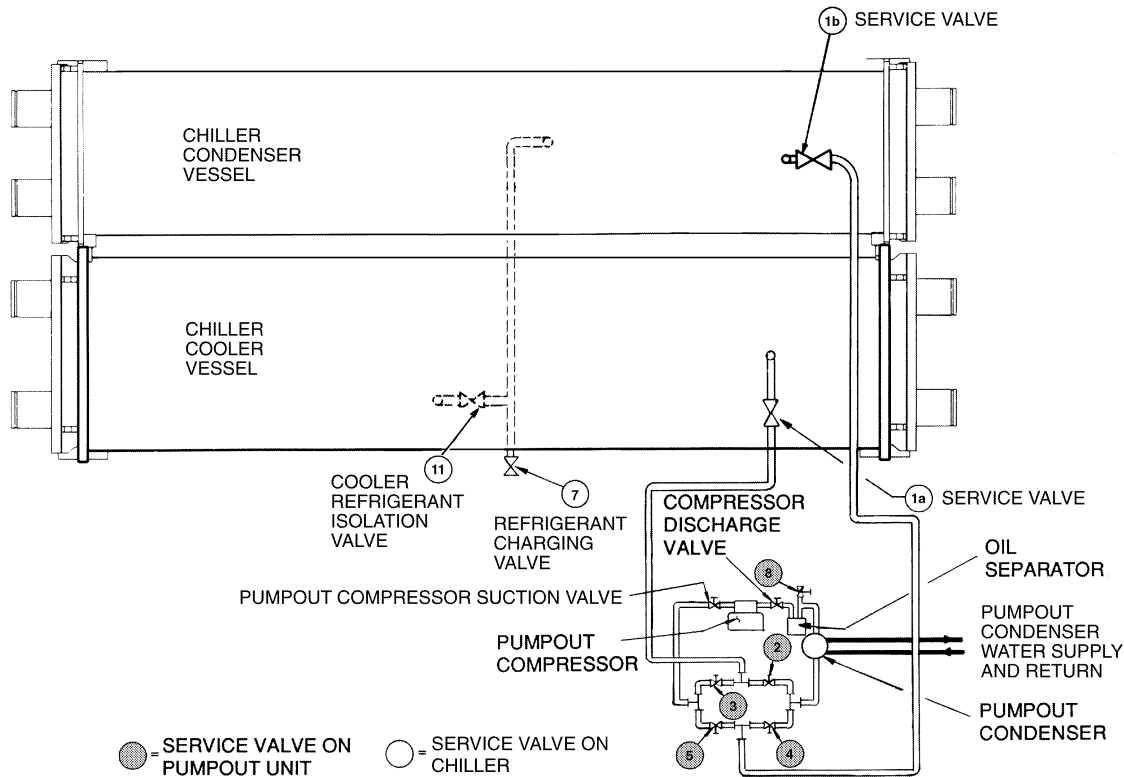

**Fig. 11 — Valve Locations for 19XB Pumpout Unit Without Storage Tank**

- d. Close valve 1a.
- e. Turn off pumpout compressor.
- f. Close valves 1b, 3, and 4.

VALVE	1a	1b	2	3	4	5	8	11
CONDITION	C	C	C	C	C	C	C	C

- g. Turn off pumpout condenser water.
- h. Turn off chiller water pumps and lock out chiller compressor.

#### Transfer All Refrigerant to Chiller Cooler Vessel:

1. Push refrigerant into the chiller cooler vessel.
  - a. Turn on the chiller water pumps and monitor the chiller pressure.
  - b. Valve positions:

VALVE	1a	1b	2	3	4	5	8	11
CONDITION				C	C		C	

- c. Equalize the refrigerant in the chiller cooler and condenser.
  - d. Turn off chiller water pumps and pumpout condenser water.
  - e. Turn on pumpout compressor to push refrigerant out of the chiller condenser.
  - f. When all liquid is out of the chiller condenser, close valve 11 and any other liquid isolation valves on the chiller.
  - g. Turn off the pumpout compressor.
2. Evacuate gas from chiller condenser vessel.
  - a. Turn on chiller water pumps.
  - b. Make sure that pumpout valves 3 and 4 are closed and valves 2 and 5 are open.

VALVE	1a	1b	2	3	4	5	8	11
CONDITION				C	C		C	C

- c. Turn on pumpout condenser water.
  - d. Run the pumpout compressor until the chiller condenser reaches 18 in. Hg (41 kPa absolute). Monitor pressure at the chiller control panel and refrigerant gages.
  - e. Close valve 1b.
  - f. Turn off pumpout compressor.
  - g. Close valves 1a, 2, and 5.

VALVE	1a	1b	2	3	4	5	8	11
CONDITION	C	C	C	C	C	C	C	C

- h. Turn off pumpout condenser water.
  - i. Turn off chiller water pumps and lock out chiller compressor.

#### Return Refrigerant to Normal Operating Conditions

1. Be sure that the chiller vessel that was opened has been evacuated.
2. Turn on chiller water pumps.
3. Open valves 1a, 1b, and 3.

VALVE	1a	1b	2	3	4	5	8	11
CONDITION			C		C	C	C	C

4. Crack open valve 5, gradually increasing pressure in the evacuated chiller vessel to 60 psig (414 kPa), [30 psig (207 kPa)]. Feed refrigerant slowly to prevent tube freeze-up.
5. Leak test to ensure chiller vessel integrity.

6. Open valve 5 fully.

VALVE	1a	1b	2	3	4	5	8	11
CONDITION			C		C		C	C

7. Close valves 1a, 1b, 3, and 5.
8. Open chiller isolation valve 11 and any other isolation valves, if present.

VALVE	1a	1b	2	3	4	5	8	11
CONDITION	C	C	C	C	C	C	C	

9. Turn off chiller water pumps.

#### DISTILLING THE REFRIGERANT

1. Transfer the refrigerant from the chiller to the pumpout storage tank as described in the Transfer the Refrigerant from Chiller to Pumpout Storage Tank section.
2. Equalize the refrigerant pressure.
  - a. Turn on chiller water pumps and monitor chiller pressures.
  - b. Close pumpout and storage tank valves 2, 4, 5, 8, and 10, and close chiller charging valve 7; open chiller isolation valve 11 and any other chiller isolation valves, if present.
  - c. Open pumpout and storage tank valves 3 and 6; open chiller valves 1a and 1b.

VALVE	1a	1b	2	3	4	5	6	7	8	10	11
CONDITION			C		C	C		C	C	C	

- d. Gradually crack open valve 5 to increase chiller pressure to 60 psig (414 kPa), [30 psig (207 kPa)]. Slowly feed refrigerant to prevent freeze-up.
  - e. Open valve 5 fully after the chiller pressure rises above the freezing point of the refrigerant. Let the storage tank and chiller pressure equalize.
3. Transfer remaining refrigerant.
  - a. Close valve 3.
  - b. Open valve 2.

VALVE	1a	1b	2	3	4	5	6	7	8	10	11
CONDITION				C	C			C	C	C	

- c. Turn on pumpout condenser water.
  - d. Run the pumpout compressor until the storage tank pressure reaches 5 psig (34 kPa), 18 in. Hg (41 kPa absolute).
  - e. Turn off the pumpout compressor.
  - f. Close valves 1a, 1b, 2, 5, and 6.
  - g. Turn off pumpout condenser water.

VALVE	1a	1b	2	3	4	5	6	7	8	10	11
CONDITION	C	C	C	C	C	C	C	C	C	C	

4. Drain the contaminants from the bottom of the storage tank into a container. Dispose of contaminants safely.

#### MAINTENANCE

Periodic maintenance is necessary to keep all components functioning as designed. A maintenance log is recommended to ensure a proper maintenance schedule is followed.

**Pumpout Unit** — For maintenance details, refer to the 06D, 07D Installation, Start-Up, and Service Instructions.

PUMPOUT COMPRESSOR OIL CHARGE — Use oil conforming to Carrier specifications for reciprocating compressor use. Oil requirements are listed in Table 6.

**Table 6 — Pumpout Compressor Oil Requirements**

REFRIGERANT	ISO VISCOSITY	CARRIER SPECIFICATION NO.	CARRIER PART NO.
R-22	86	PP49-7	PP23BZ101
R-134a	68	PP47-31	PP23BZ103

The total oil charge, 4.5 pints (2.6 L), consists of 3.5 pints (2.0 L) for the compressor and one additional pint (0.6 L) for the oil separator.

Oil should be visible in one of the pumpout compressor sight glasses both during operation and at shutdown. Always check the oil level before operating the pumpout compressor. Before adding or changing oil, relieve the refrigerant pressure as follows:

1. Attach a pressure gage to the gage port of either pumpout compressor service valve (Fig. 10).
2. Close the suction service valve and open the discharge line to the pumpout storage tank or the chiller.
3. Operate the compressor until the crankcase pressure drops to 2 psig (13 kPa).

4. Stop the pumpout compressor and isolate the pumpout system by closing the discharge service valve.
5. Slowly remove the oil return line connection (Fig. 9). Add oil as required.
6. Replace the connections and reopen the pumpout compressor service valves.

**Storage Tank** — To prevent moisture and contaminants from entering the storage tank, maintain positive pressure in the tank when not transferring refrigerant. Leak test the storage tank according to your normal vessel leak test procedures and schedule.

**Ordering Replacement Parts** — The following information must accompany an order for Carrier-specified parts:

- machine model number and serial number
- name, quantity, and part number of the part required
- delivery address and method of shipment

## TROUBLESHOOTING

Information on troubleshooting for the PPS is included in Table 7.

**Table 7 — Troubleshooting**

SYMPTOM	PROBABLE CAUSE	REMEDY
<b>Compressor does not run</b>	Main power line open	Replace fuse or reset circuit breaker.
	Loose terminal connection	Check connections.
	Improperly wired controls	Check wiring and rewire.
	Low line voltage	Check line voltage; determine location of voltage drop.
	Compressor motor defective	Check motor winding for open or short. Replace compressor if necessary.
	Seized compressor	Replace compressor.
<b>Compressor cycles on high-pressure control</b>	High level gage alarm	Check refrigerant level and remove excess.
	High-pressure control erratic in action	Check capillary tube for pinches. Set control as required..
	Discharge valve partially closed.	Open valve.
	Air in system	Purge system.
	Condenser scaled.	Clean condenser.
<b>Unit operates too long</b>	Condenser water pump or fans not operating.	Start pump or fans.
	Isolation valves partially open	Close valves.
<b>System Noises</b>	Piping vibrations	Support piping as required. Check for loose pipe connectors.
	Compressor noisy	Check valve plates for valve noise. Replace compressor (worn bearings). Check for loose compressor holddown bolts.
	Insufficient compressor oil	Add oil.
<b>Compressor Loses Oil</b>	Leak in system	Locate and repair leak.
	Plugged or stuck compressor oil return check valve	Repair or replace valve.
	Dirty accumulator	Clean accumulator.