

Instructions



Important Safety Instructions

Read all warnings and instructions in this manual and in the sprayer operation manual. Save these instructions.

Lacquer Conversion Kit 256212

312933D

EN

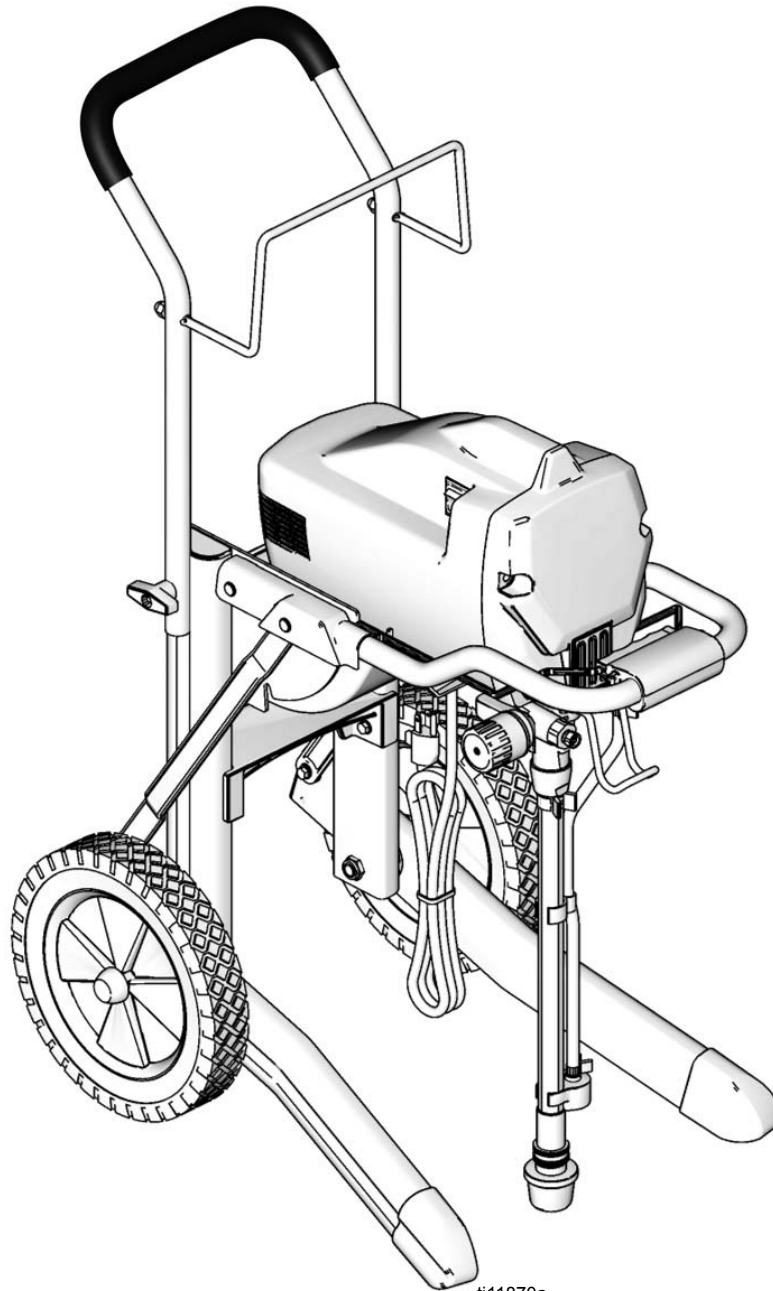

ti11870a

Lacquer Conversion Kit 256212

Ref.	Part No.	Description	Qty
1	117559	O-RING, CV-75, size 020	2
2	111507	O-RING, CV-75, size 013	1
3	111316	O-RING, CV-75, size 012	1
4	15D370	O-RING, CV-75, size 022	1
5	15D371	O-RING, CV-75, size 015	2
6	15D252	O-RING, CV-90, size 008	1
7	119400	SEALANT, pipe, sst	1
8	15D883	TUBE, suction	1

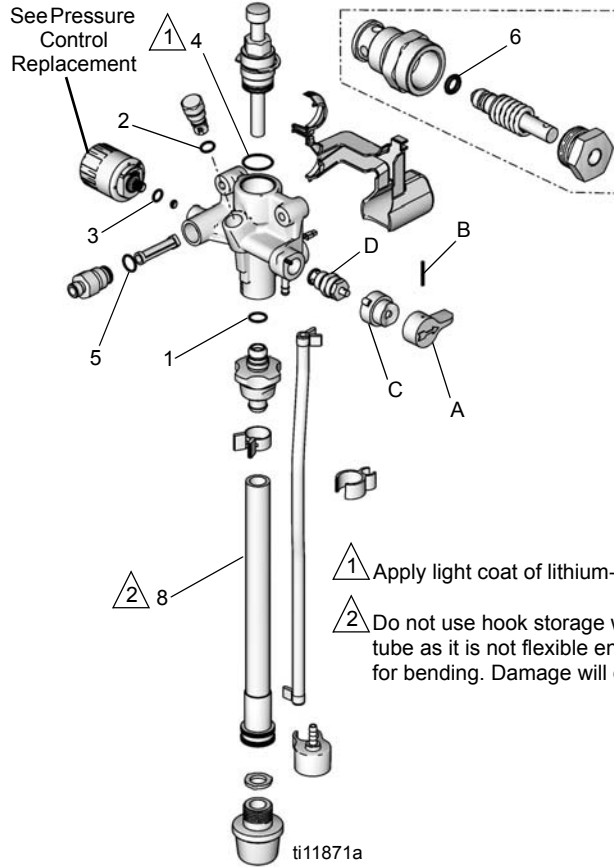
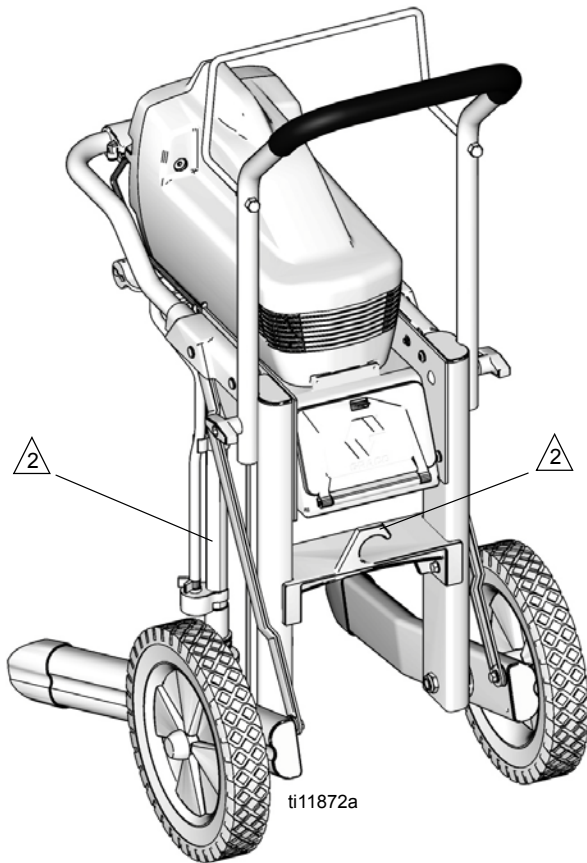

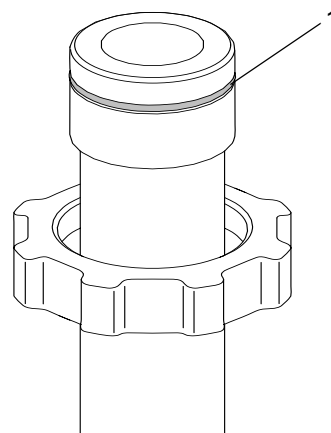

- 1 Apply light coat of lithium-based grease
- 2 Do not use hook storage with new suction tube as it is not flexible enough to allow for bending. Damage will occur.

240V Sprayers Only



Pressure Relief Procedure

					
<p>To help prevent injection injuries, follow this procedure when you stop spraying and before you service or clean the sprayer, remove parts, or repair leaks.</p>					

1. Turn power switch to OFF.
2. Unplug sprayer.
3. Turn knob (A) down to PRIME/DRAIN.
4. Hold metal part of gun firmly to a grounded metal pail. Pull gun trigger to relieve pressure.

Instructions

1. Turn knob (A) up to SPRAY position.
2. Remove pin (B) with pin punch and hammer.

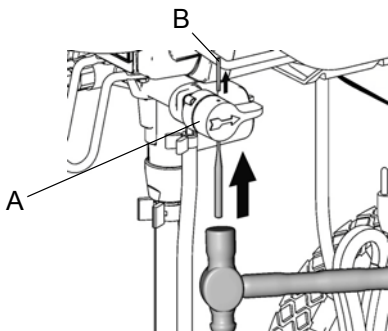

3. Remove knob (A) and base (C).

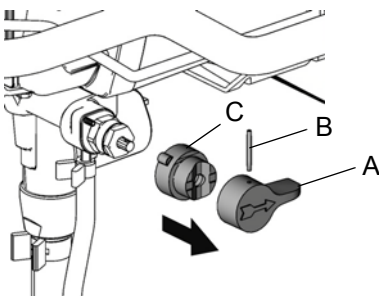

4. Remove valve stem (D) from manifold. Be sure gasket (X) and seat (Z) do not stay in manifold.

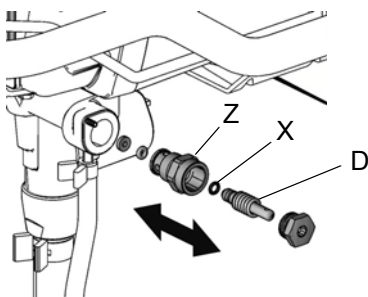

5. Replace brown o-ring (6) on end of valve stem. Apply sealant (7) to valve threads. Install valve stem in pump manifold. Torque to 185 in-lb (21 N•m).
6. Install base (C) on valve, aligning pin (E) on base (C) with hole (F) on manifold.

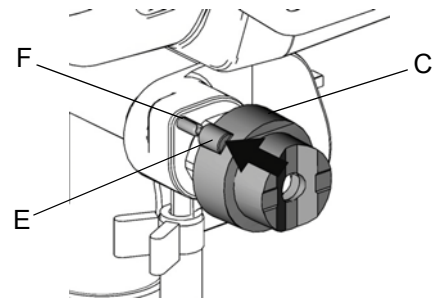

7. Rotate valve stem with a pin punch until hole is perpendicular.

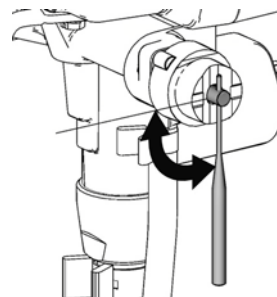

8. Install knob (A) over base (C).
9. Place knob in SPRAY position.
10. Insert end of pin punch through hole in knob (A), to make sure knob and valve stem are aligned.

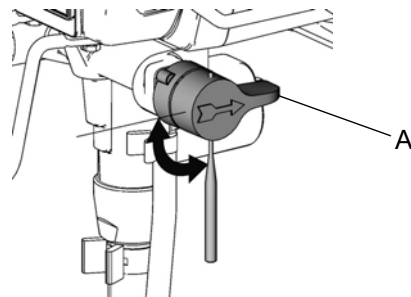

11. Install pin (B) through hole in knob (A). Tap pin through knob with hammer. End of pin will be flush with top of hole in knob when correctly installed.

X5, X7, LTS 15, and LTS 17 Pressure Control Replacement

Disassembly

1. Unplug electrical cord and **Relieve Pressure**. See **Pressure Relief Procedure** on page 3.
2. **X7 and LTS 17 Only:** Remove underside shroud mounting screw (D).
3. Remove side shroud screws (E) (T-20 Torx).
4. Remove 4 front cover screws (F) (T-30 Torx).
5. Remove shroud (G).
6. Disconnect power cord connectors (H) from ON/OFF switch (L).
7. Remove shroud (K).
8. **Series A:** Remove 2 pump housing mounting screws (ps). Be sure to support pump housing (ph).
9. **Series A:** Remove pump housing (ph). **X7 and LTS 17 Only:** Pull power cord (N) through opening in pump housing mounting bracket (pb).
10. Disconnect pressure control harness from control board connector (cb). Take note of wire routing; new wires will be rerouted the same way.
11. **Series A:** Remove AutoPrime cover (A) by releasing tab underneath pressure control knob.
Series B: Release tab underneath function indicator (fi) and remove indicator and front cover.
12. Turn pressure control knob fully counterclockwise to expose wrench flats. Remove pressure control (P). Verify the o-ring seal (or) has been removed from the pump (J).

Assembly

NOTICE

Do not pinch wires between pressure control (P) and pump housing (ph) pump mounting bracket (pb) and shrouds (G and K) while assembling.

1. Examine new pressure control (P) to verify o-ring seal (or) is in place. If o-ring seal is not installed on pressure control, install seal.
2. Apply one or two drops of thread locking adhesive (included in kit) to threads of pressure control switch (P). Assemble pressure control switch (P) into pump (J). Torque to 140-160 in.-lbs (16-18 N•m).
3. **Series A:** Route pressure control (P) harness as shown in harness routing detail on page 12. Con-

nect to control board connectors (cb) (connect with tab in front). Install AutoPrime cover (A) and latch tab.

4. Install pump housing (ph) with 2 pump housing mounting screws (ps) onto pump housing mounting bracket (pb). Torque to 110 to 120 in-lb (12.4 to 13.6 N•m).
5. **Series B:** Route pressure control harness through function indicator (fi) and front cover. Install indicator on pump and snap together. Align indicator and front cover as they are positioned loosely on pump. Connect harness to control board terminals (cb).
6. Reattach power cord connectors (H) to ON/OFF switch (L).
7. Install shroud (K).
8. **X7 and LTS 17 Only:** Route power cord (N) through opening in pump housing mounting bracket (pb).
9. Install power cord (N) into recess on left shroud (K).
10. Install shroud (G) to shroud (K) and front cover.
11. Install side shroud screws (E) (T-20 Torx). Torque to 20 to 25 in-lb (2.3 to 2.8 N•m).
12. Install 4 front cover screws (F) (T-30 Torx). Torque to 26 to 32 in-lb (2.9 to 3.6 N•m).
13. **X7 and LTS 17 Only:** Install underside shroud mounting screw (D). Torque to 25 to 35 in-lb (2.8 to 3.9 N•m).
14. Turn pressure control switch knob (P) clockwise as far as it will go. Apply pressure control label (cl) to knob. To position label correctly, see note below:

NOTE: When properly positioned, the function indicator (fi) and hi-spray position symbol on pressure control label (cl) are aligned.

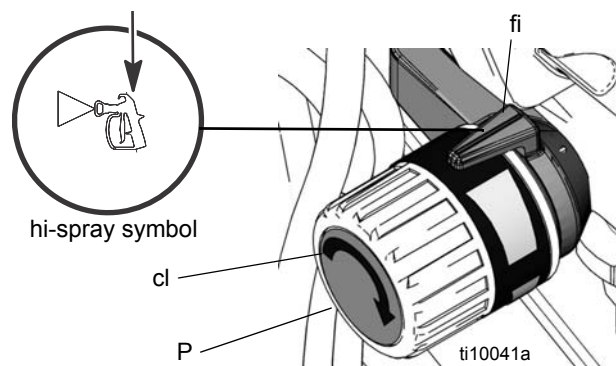

X5 and LTS 15 Model Sprayers (Series A unit shown)

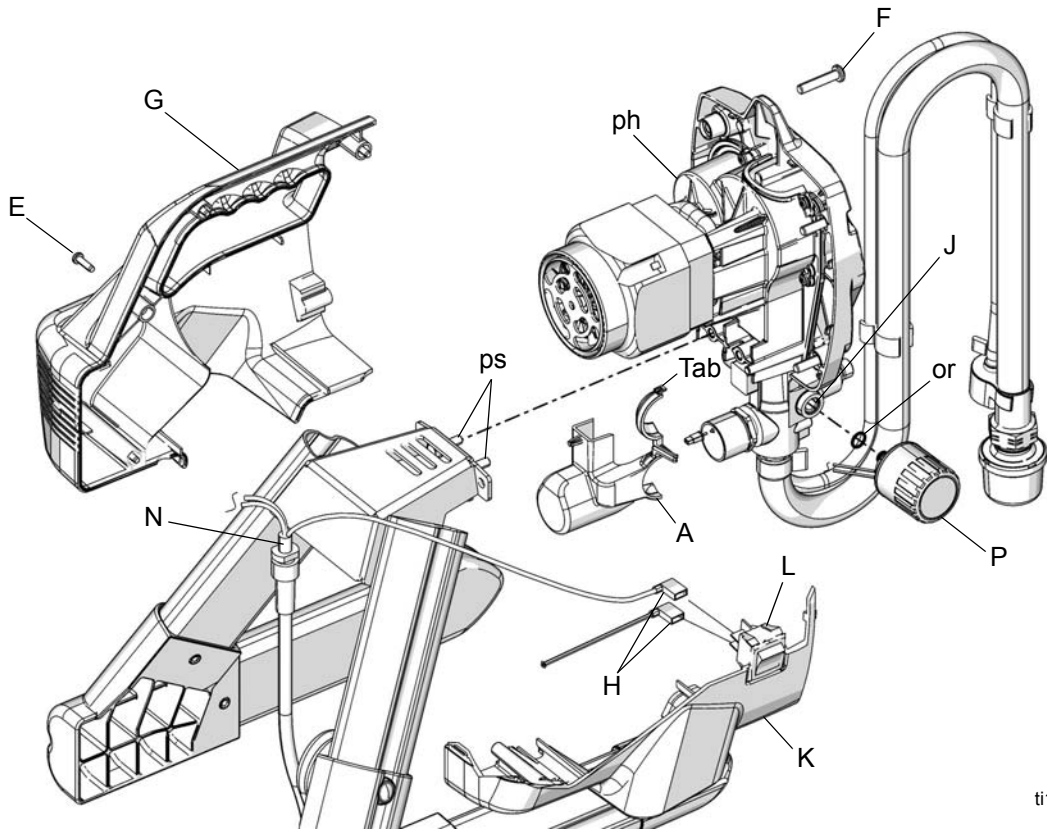

ti11886a

X7 and LTS 17 Model Sprayers (Series A unit shown)

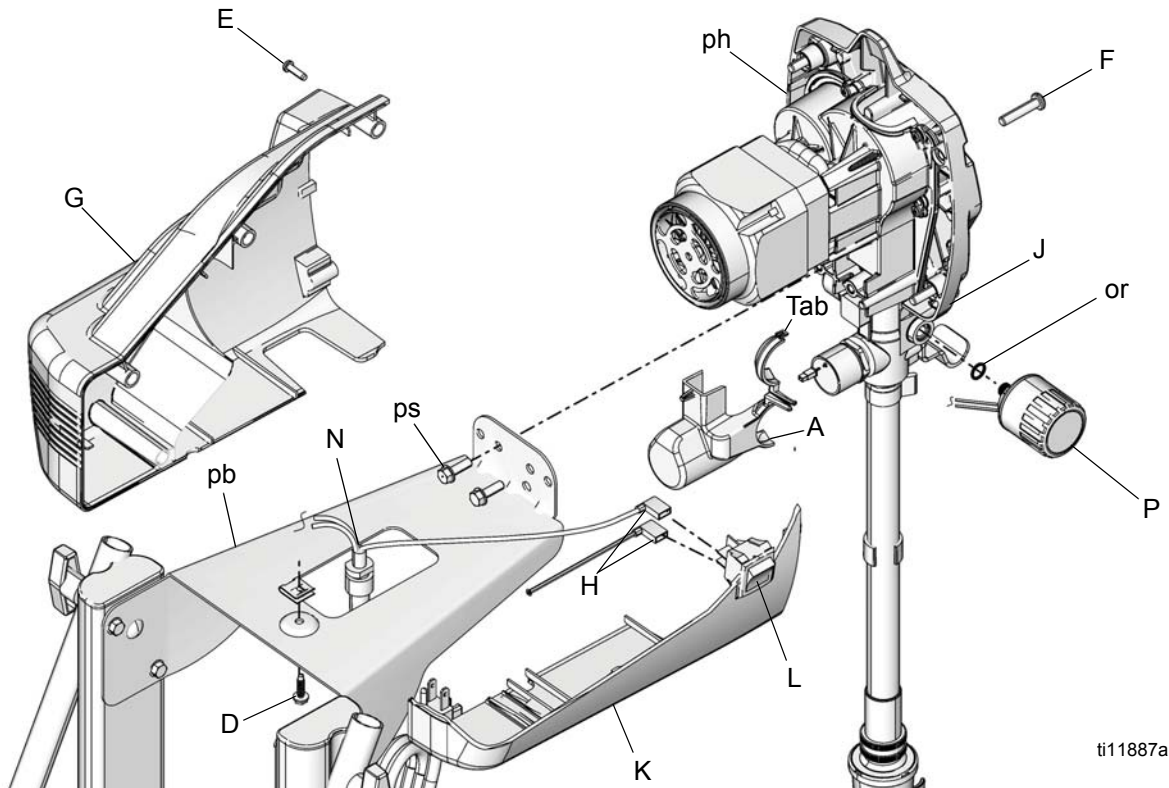

ti11887a

X5, X7, LTS15, and LTS17 (Series A) Wire Routing

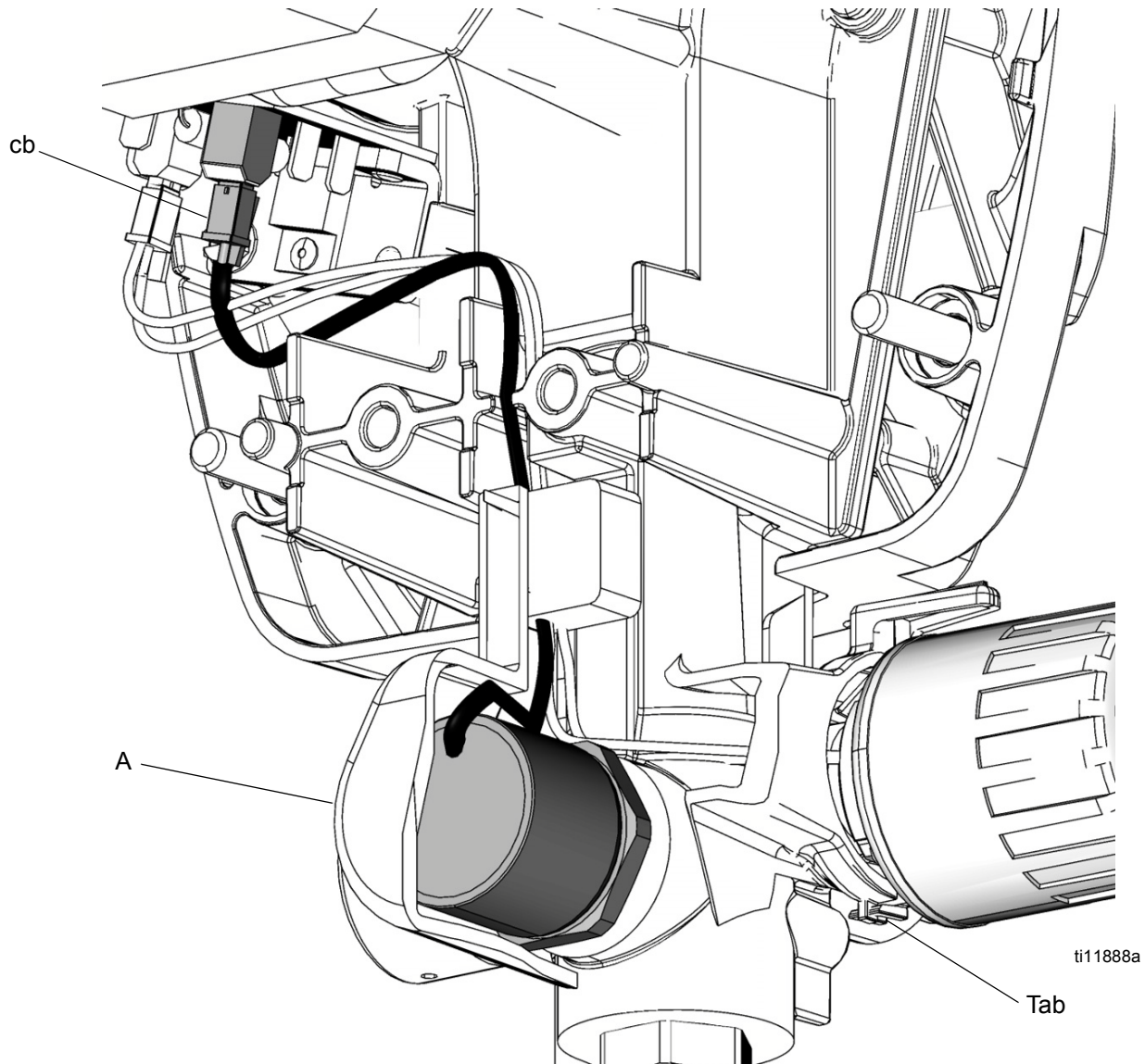

Graco Information

For the latest information about Graco products, visit www.graco.com

TO PLACE AN ORDER, contact your Graco distributor or call 1-800-690-2894 to identify the nearest distributor.

*All written and visual data contained in this document reflects the latest product information available at the time of publication.
Graco reserves the right to make changes at any time without notice.*

For patent information, see www.graco.com/patents.

Original instructions. This manual contains English. MM 312933

Graco Headquarters: Minneapolis
International Offices: Belgium, China, Japan, Korea

GRACO INC. AND SUBSIDIARIES • P.O. BOX 1441 • MINNEAPOLIS MN 55440-1441 • USA

Copyright 2008, Graco Inc. All Graco manufacturing locations are registered to ISO 9001.

www.graco.com

Revised September 2013